

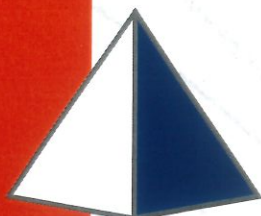

Finebrush 1350

Sanding and structuring machine



EMC

Wood Division



The highest quality
finishing



Configurazione 3 operatori
Configuration 3 groups
Configuration à 3 groupes



Gruppo spazzola
Brushing unit
Groupe de brosse à Brosse

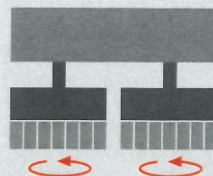

Gruppo spazzole tangenziali 2x
Tangential brushes unit 2x
Unité de Brosse Tangentielle 2x

K 1350



Applications

MDF • MEDIUM DENSITY

DISASSEMBLED DOORS

SOLID WOOD

MOULDINGS

VENEER SANDING

KITCHEN DOORS-RAISED PANELS

LAQUER SANDING-DENIBBING

FURNITURES

WATER BASE LACCA SANDING

RUSTIC AND DISTRESSING

INTERNAL AND EXTERNAL
DOORS-WINDOWS

AND MORE...

Finebrush 1350

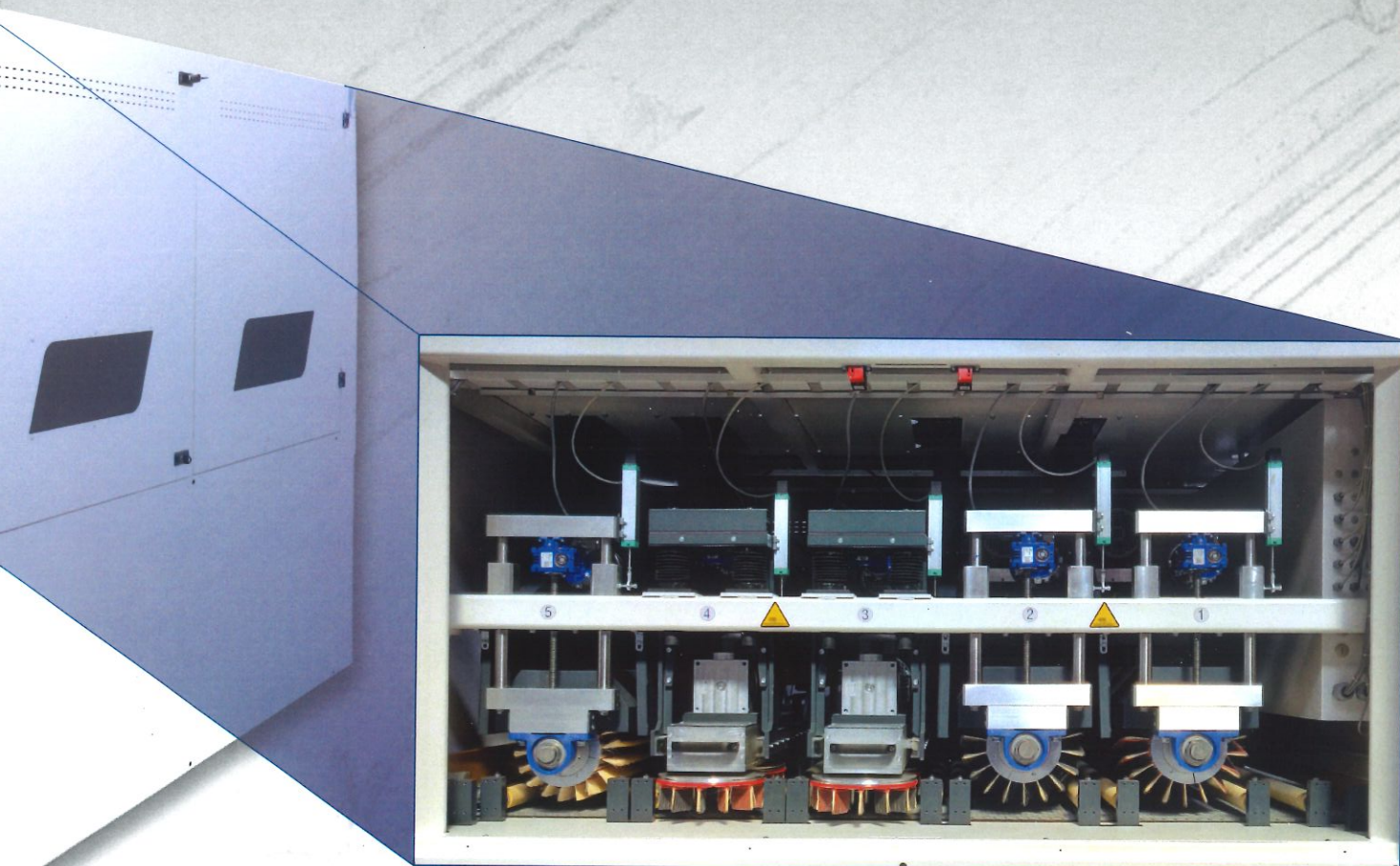

Configurazione 5 operatori
Configuration 5 groups
Configuration à 5 groupes

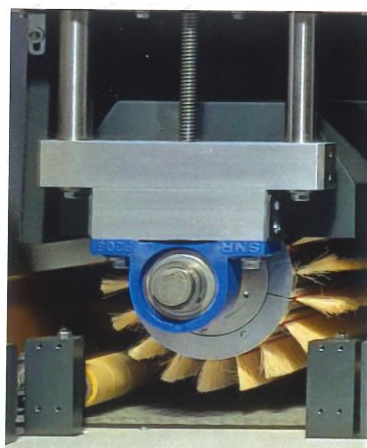

Gruppo spazzola
Brushing unit
Groupe de brossage
à Brosse

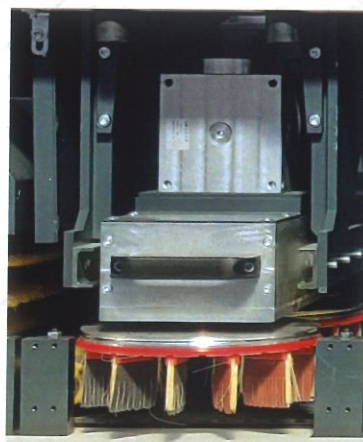

Gruppo spazzole
tangenziali 1x
Tangential brushes unit 1x
Unité de Brosse
Tangentielle 1x



Spazzola pulizia pezzi
Brush for panels cleaning
Brosse nettoyage des pièces



Soffiatore compatto
Compact belts blower
Soufflette compacte

Finebrush 1350

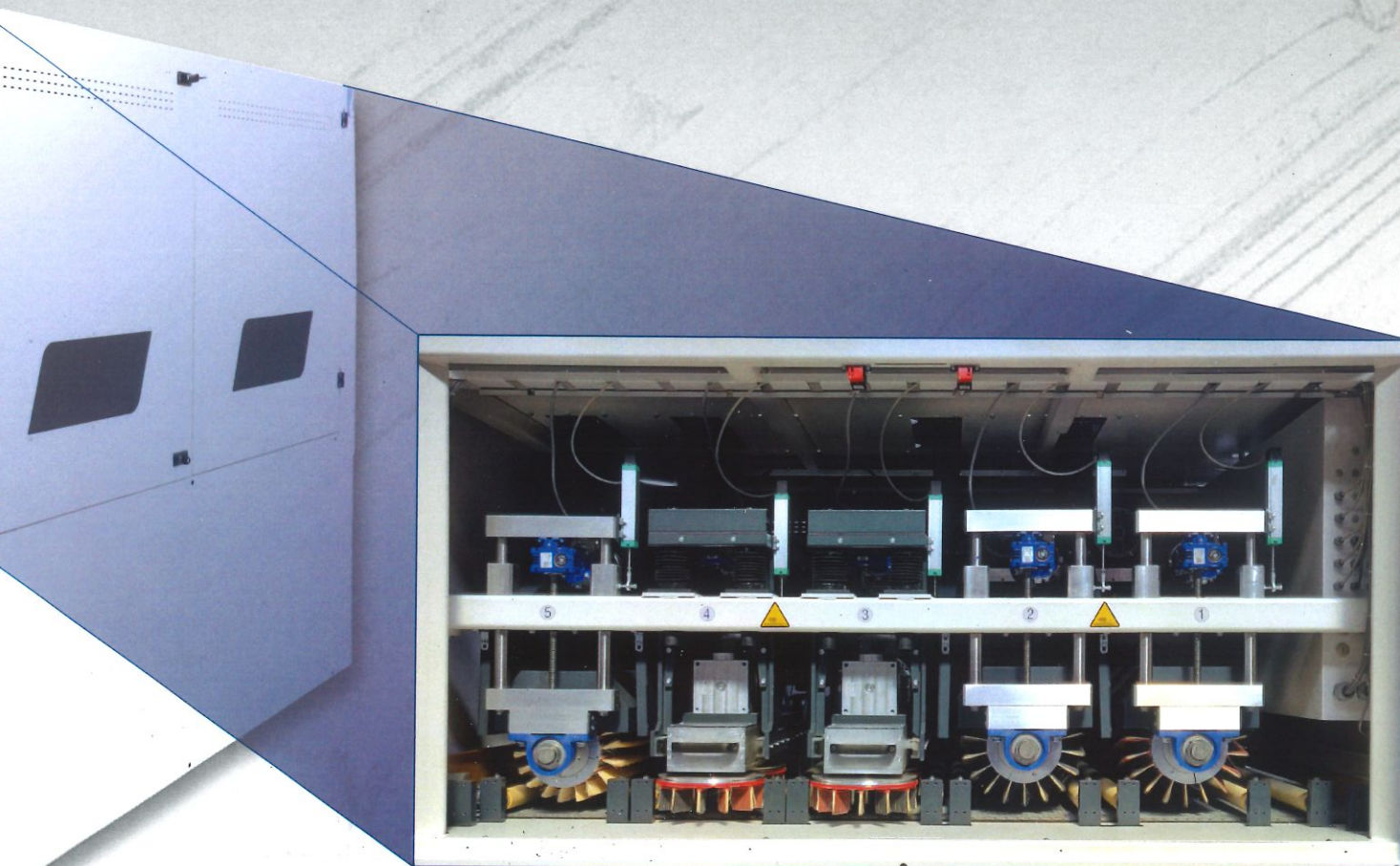

Configurazione 5 operatori
Configuration 5 groups
Configuration à 5 groupes

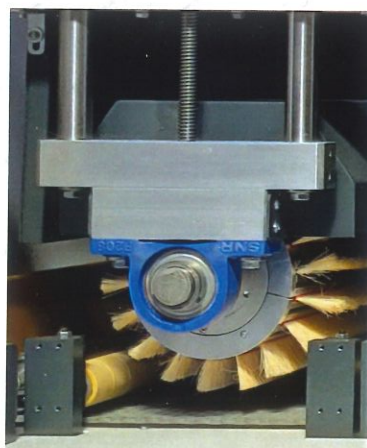

Gruppo spazzola
Brushing unit
Groupe de brossage
à Brosse

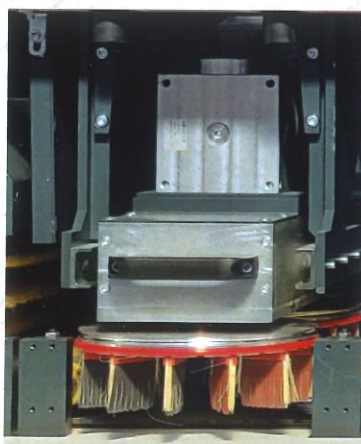

Gruppo spazzole
tangenziali 1x
Tangential brushes unit 1x
Unitè de Brosse
Tangentielle 1x



Spazzola pulizia pezzi
Brush for panels cleaning
Brosse nettoyage des pièces

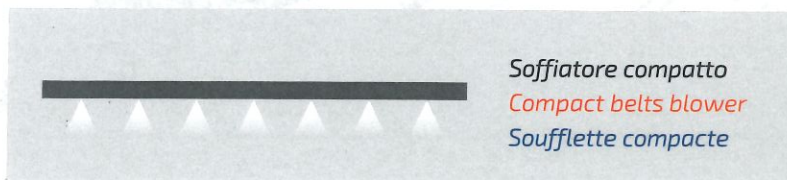

Soffiatore compatto
Compact belts blower
Soufflette compacte



Finebrush-K 1350

Sanding and structuring machine

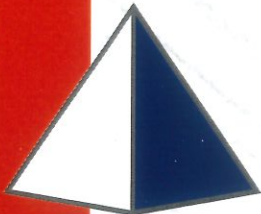

EMC

Wood Division



Finebrush 1350

MACHINE DIMENSIONS= 2050X3300X2200 (LxPxH) mm

MACCHINA BASE
BASIC MACHINE
MACHINE DE BASE

- ✓ Altezza fissa 900mm
Fixed height 900mm
Hauteur table fixe 900 mm
- ✓ Larghezza utile di lavoro 1350mm
Working width 1350mm
Largeur utile de travail 1350 mm
- ✓ Spessore di lavoro min/max 3-140mm
Working thickness min/max 3-140mm
Épaisseur de travail min/max 3-140mm
- ✓ Velocità di avanzamento del tappeto 0,4 - 6 m/min
Feed belt speed 0.4 - 6 m / min
Vitesse d'entrainement du tapis 0,4-6 m/min
- ✓ Controllo, visualizzazione e programmazione pressione di lavoro
Control, display and programming work pressure
Control, visualisation et programmation de la pression de travail
- ✓ Recupero programmabile del consumo delle spazzole
Programmable brush consumption compensation
Récupération programmable de l'usure des brosses
- ✓ Controllo delle velocità indipendenti
Control of speed independently
Control des vitesses indépendentes



Finebrush-K 1350

MACHINE DIMENSIONS= 1800X2300X1950 (LxPxH) mm

MACCHINA BASE
BASIC MACHINE
MACHINE DE BASE

- ✓ Larghezza utile di lavoro 1350mm
Working width 1350mm
Largeur utile de travail 1350 mm
- ✓ Spessore di lavoro min/max 3-140mm
Working thickness min/max 3-140mm
Épaisseur de travail min/max 3-140mm
- ✓ Velocità di avanzamento del tappeto 0,4 - 6 m/min
Feed belt speed 0.4 - 6 m / min
Vitesse d'entrainement du tapis 0,4-6 m/min
- ✓ Controllo delle velocità indipendenti
Control of speed independently
Control des vitesses indépendentes



Need Help?

No problem. Just connect the electronic cable we gave you to the machine. EMC technician will do the rest of the job.



**"Sanding is an Art, which comes from the Heart".
And we have a big Heart.**



Via Brodolini, 23 - 40026 Imola (Bo) Italy
Tel. +39 0542 688034 - Fax +39 0542 643959
E-mail: info@emc-italia.it



EMC italia srl

www.emc-italia.it