

podis®

BEHIND **EV CHARGING**

The system solution for an innovative charging infrastructure.

CLICK AND DONE.



THE INNOVATION BEHIND.

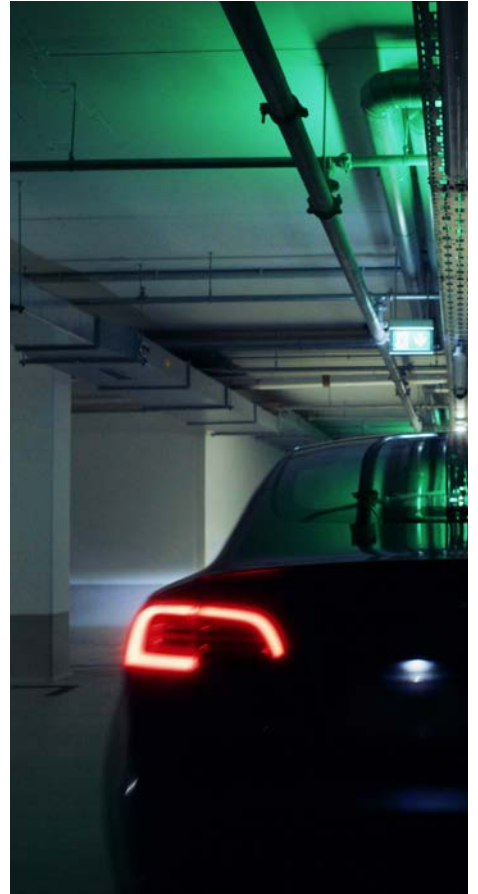

THE MOBILITY TURNAROUND FOR THE UNDERGROUND CAR PARK

The podis® flat cable system is the innovative system solution for decentralized energy distribution. Quick to install and flexibly expandable, it is ideally suited to making buildings fit for the mobility transition and setting up the charging infrastructure required for e-mobility.

E-mobility is the topic of the moment. The increasing number of electric vehicles on our roads brings with it the need to build a reliable charging infrastructure. Legal regulations on the expansion of private charging infrastructure pose new challenges for planners, property owners and parking garage operators.

While the planning of energy distribution for charging stations in new buildings may still be easy to implement, retrofitting existing buildings is often associated with considerable difficulties. Then there is the question of what needs to be planned for. But we have good news: the podis® flat cable system solves these problems.

APPLICATIONS

- + For underground garages and Parking garages
- + For charging stations up to to 22 kW
- + Up to 20 charging stations working together



FEATURES

- 5-core flat cable system
- IP protection class 65
- Construction Products Regulation Class B2_{ca}
- UV resistance
- Modern appearance



ADVANTAGES

- Time-saving installation: no cutting and stripping necessary
- Fast expansion: Perfectly suited for retrofitting when charging stations are required at different times
- Decentralized system saves space

A photograph of a dark blue car, possibly a Tesla, parked in a parking garage. The scene is illuminated with a strong blue light, highlighting the car's sleek design and the surrounding environment. The ceiling is filled with a complex network of pipes and conduits. A white pillar stands to the left of the car. In the background, two bicycles are hanging from a rack. The overall atmosphere is modern and industrial.

BEHIND EV CH



AND CHARGING: PODIS®



DECENTRAL INSTALLATION

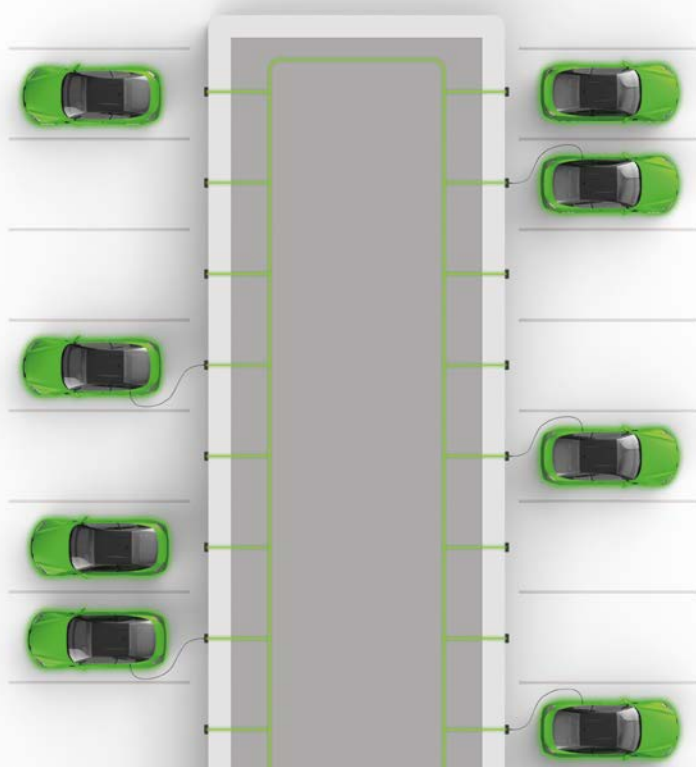

Decentralized installation with podis® allows you to implement energy distribution for an entire parking deck with just one supply line and place the modules for energy exactly where you need them. This saves space and ensures a modern and clear aesthetic.



- + Low space requirement
- + High flexibility during installation, for conversion and expansion
- + High material and Cost savings

HOW FAST CAN YOU SAY "SAVE"?

S.

CENTRAL INSTALLATION

A central installation means significantly higher material costs compared to a decentralized installation. The large number of supply lines also means that considerable space is required in the distribution cabinet. Retrofitting thus becomes a Herculean task.

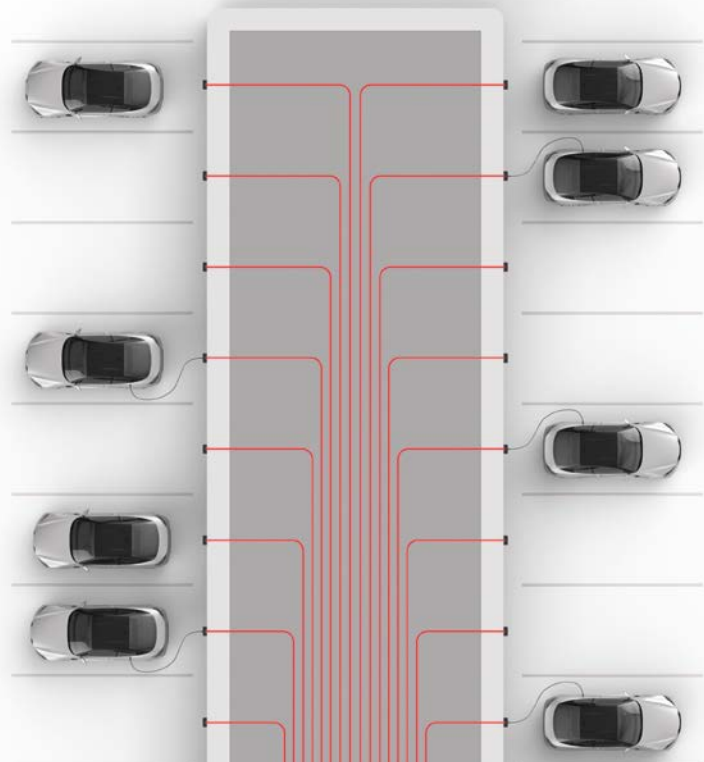

- + Immense space requirement for Cable routing and fuse protection
- + Time-consuming installation
- + Cost-intensive due to high Cost of materials



66%

TIME SAVED AT THE FIRST INSTALLATION



88%

TIME SAVED FOR EXTENSIONS



66%

SAVED ON MATERIALS



30%

INSTALLATION COSTS SAVED

TYPES OF INSTALLATION OF PODIS®

Two flexible options for every project: install the supply for your charging stations quickly and easily with our podis® flat cable and the connection modules

with cable glands. You can save even more time by combining it with the RST® system by replacing the connection modules that serve the charging

station with plug-in connection modules. The feed into the flat cable is still realized with the connection module for conventional wiring.

INSTALLATION WITH CONVENTIONAL WIRING

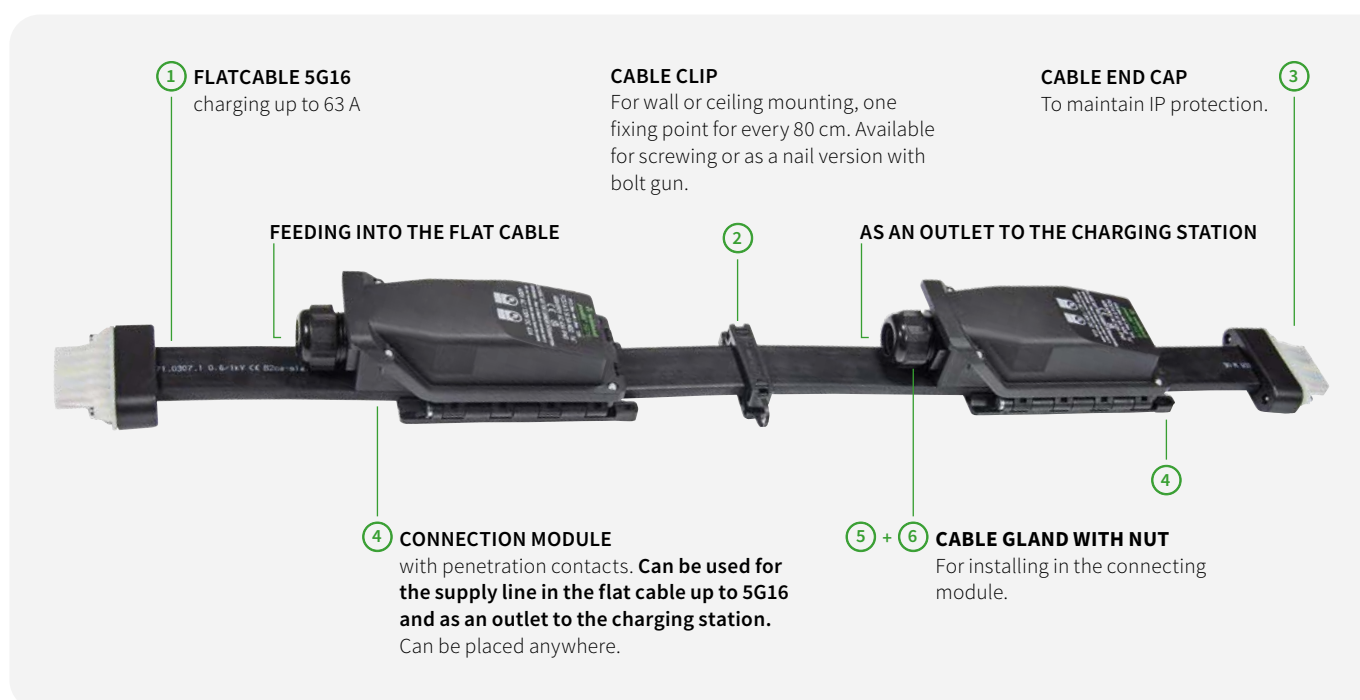

FEATURES

- Outgoing module with conventional wiring
- Wiring the connection modules at the installation site
- Connection cross-section of outgoing cable 1.5 - 16 mm²
- Rated current 63 A
- Rated voltage up to 690 V

PODIS® FLAT CABLE WITH ACCESSORIES

Designation	Art. No.
① Flat cable 5G16	00.771.0307.1
② Cable clip Screw	05.569.7453.0
③ Cable end cap	Z6.563.6553.0

CONNECTION MODULE WITH ACCESSORIES

Designation	Art. No.
④ Connection module with cut-out for cable gland	75.456.0053.1
⑤ Cable gland 18-25 mm	Z5.507.1653.1
⑥ Nut	05.505.0353.1



INSTALLATION WITH RST® PLUGGABLE SYSTEM

**PLUG +
PLAY**



SIMPLY BECOMING PLUG-IN

For plug-in outlets to the charging stations, replace positions 4, 5 and 6 with position 7 and one of the positions from 8 – 13.



7 CONNECTION MODULE RST25
Connecting module with integrated plug-in connection to the 5-pole RST® system.



8 - 13 CONNECTION CABLE RST25 H05Z1Z1 - 5G6 cable assembled with RST® plug-in connector and open end.

FEATURES

- Pluggable outgoing module with RST25
- Factory-assembled cables with RST® connector system
- 5G6 round cable
- Up to 32 A taking into account the derating curve (see Technical Appendix)
- Rated voltage 400 V

PLUG-IN CONNECTION MODULE AND ASSOCIATED ASSEMBLED CABLES

Designation	Art. No.
7 Connection module, plug-in RST25	75.453.0053.1
8 Connection cable 5G6 RST25 0.5 m	99.456.0124.0
9 Connection cable 5G6 RST25 1.0 m	99.453.0124.0
10 Connection cable 5G6 RST25 1.5 m	99.454.0124.0
11 Connection cable 5G6 RST25 2.0 m	99.455.0124.0
12 Connection cable 5G6 RST25 2.5 m	99.459.0124.0
13 Connection cable 5G6 RST25 3.0 m	99.460.0124.0

1x feed-in with conventional wiring module up to 63 A



All outlets to the charging stations with plug-in module up to 32 A

CONNECTION MODULE: STRUCTURE + ASSEMBLY

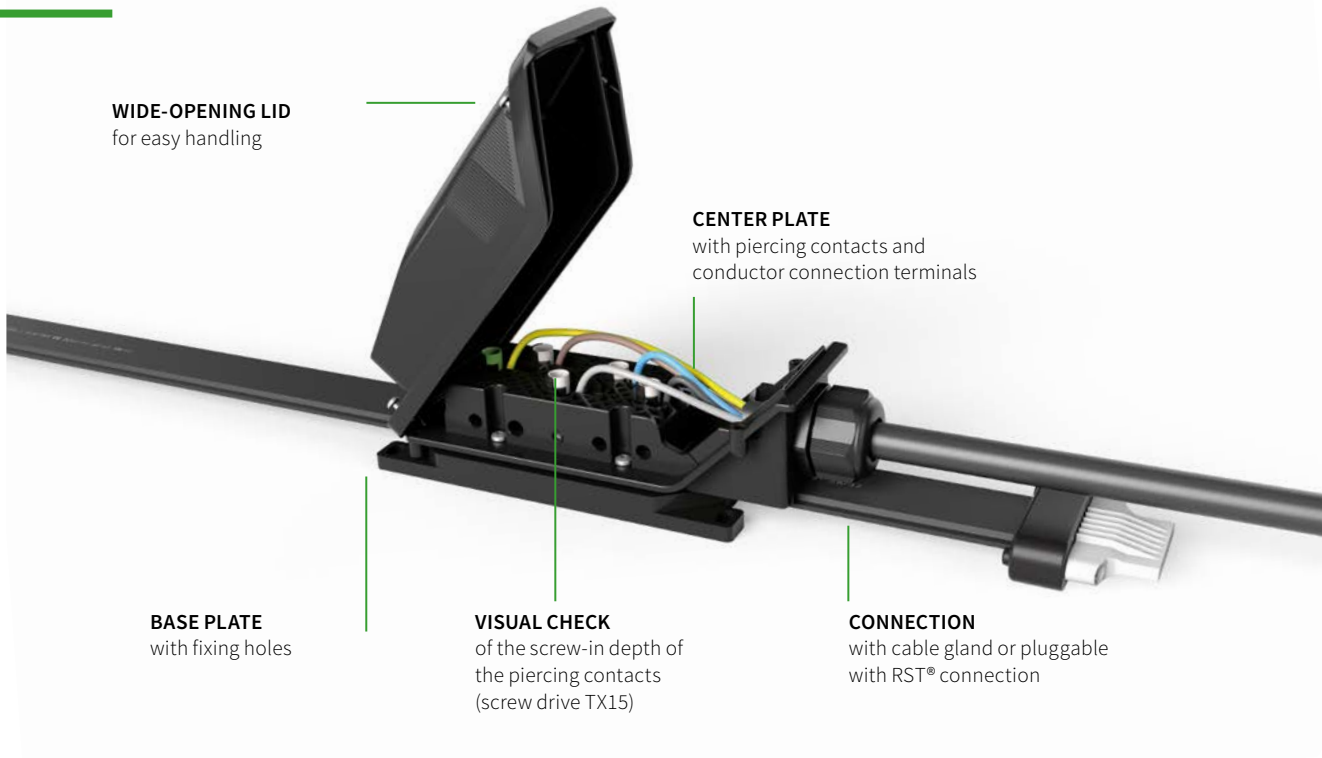

See here step by step how quickly and easily the podis® flat cable system can be installed.



The tap-off modules can be placed anywhere on the flat cable.



The conductors are connected in the center plate. These are already connected in the plug-in version with RST®.

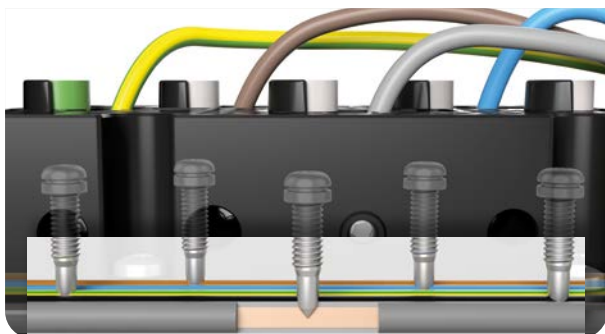

The connection to the flat cable is established via contact screws.



The end piece is attached to the open ends of the flat cable to maintain the IP protection.



The flat cable system can be easily surface-mounted in existing buildings. In this example, the connection module is used as a center feed.

The 5G16 flat cable system can be connected directly to the charging station with a conventional or pluggable outlet using a cable with a reduced cross-section. You can find out what needs to be taken into account here.

Alternative solutions with integrated fuse protection in the connection module can be found on page 14.



Statement



Decentralized installation, conversion and extension with podis®
Compared to classic installation

View now at  / **WielandElectric** !

SAFE, NOT SORRY.



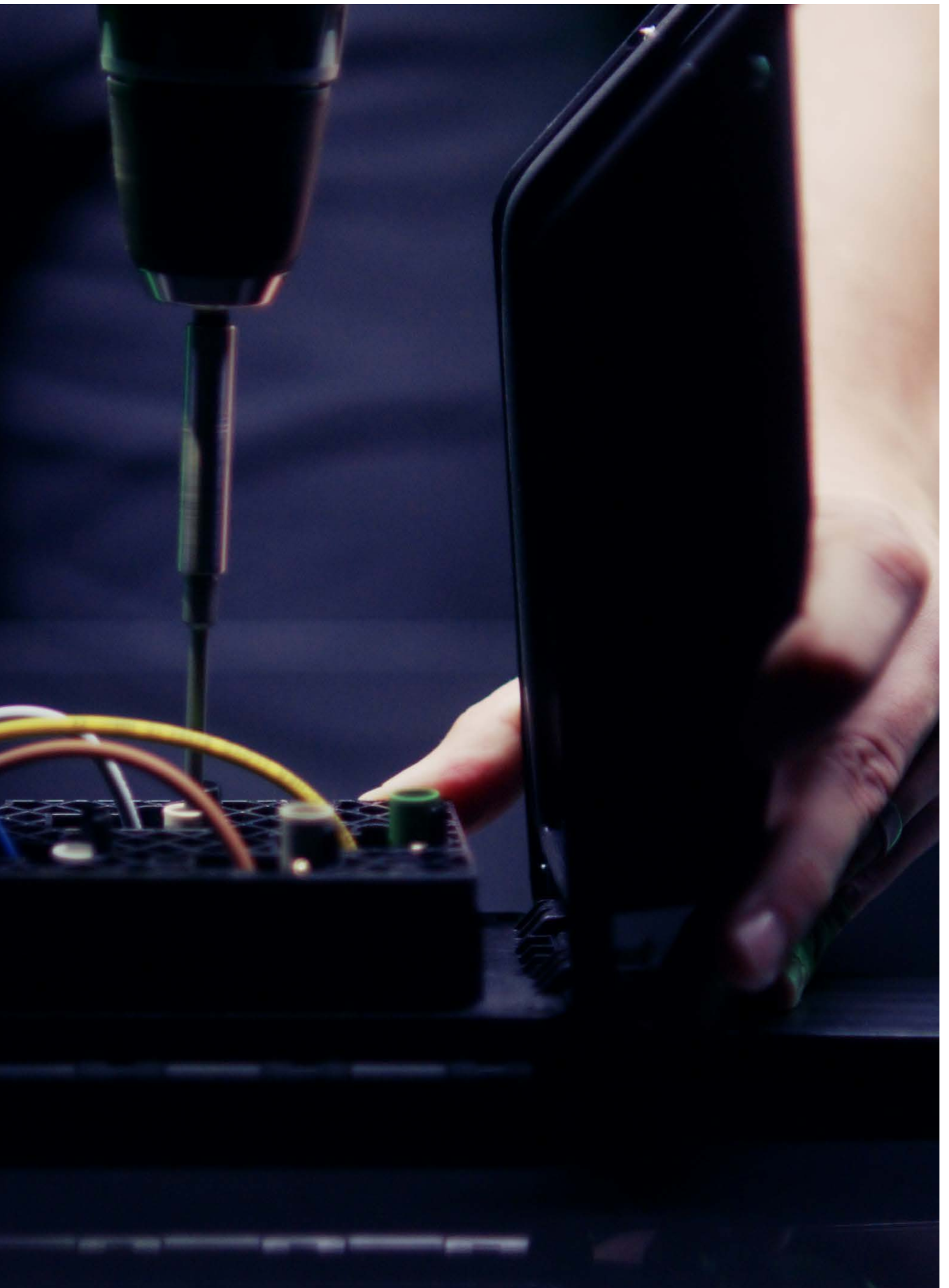

PODIS® CIRCUIT BREAKER MODULE: AGAINST RESIDUAL AND OVERCURRENT

The podis® circuit breaker module serves both as a connection to the flat cable and for integrating the overcurrent and residual current protection device for the final circuit.

In accordance with IEC 60364-7-722:2018, the overcurrent and residual current protective devices for protecting the charging stations must be installed in the branching final circuits of each charging station. These can be integrated either in the charging station itself or in a podis® circuit breaker module specially designed for electromobility.

Here too, there are variants for fixed wiring with cable gland output or pluggable with RST20i5 and RST25i5.

CONVENTIONAL WIRING

The conventional variants come with a 4-pole RCBO type A C32 / 30 mA or RCBO type A C16 / 30 mA and an SL terminal block. These can be used for 22 kW or 11 kW charging stations, for example, which have integrated DC residual current detection. Other variants (e.g. with alternative in-line installation device) can be offered on request.

PLUGGABLE WITH RST®

The pluggable outputs of the circuit breaker modules offer different mechanical codings. This prevents incorrect mating. These are colored for easier visual differentiation. The modules with 4-pole RCBO type A C32 / 30 mA have an integrated concrete gray output, the modules with RCBO type A C16 / 30 mA have an integrated black output.

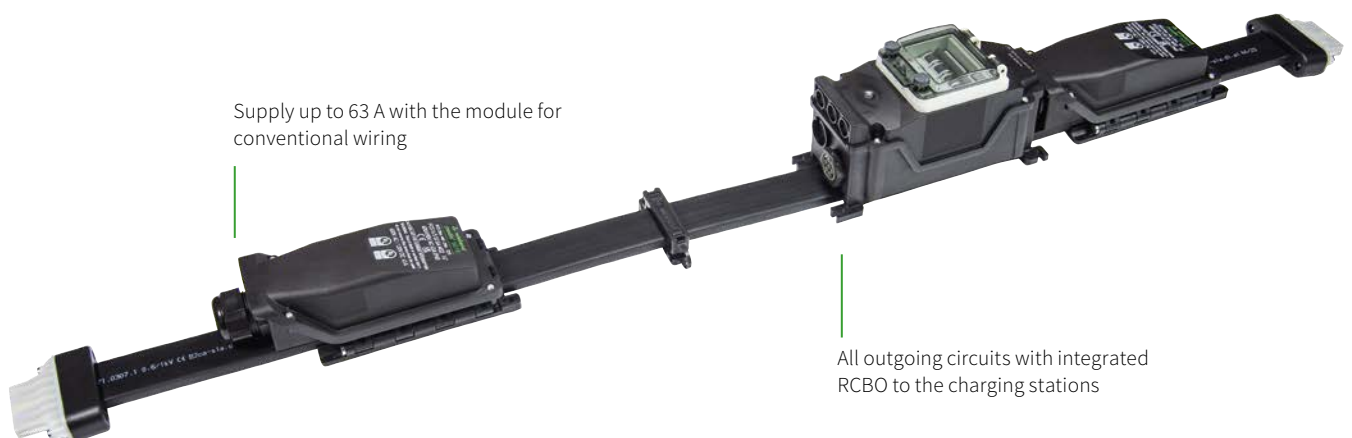



FEATURES

- Built-in RCBO
- Completely pre-wired pluggable models with RST® or models wired up to the internal device with output for cable gland (6 mm² each)
- Protection rating IP65
- Lockable with separate lock



YOUR BENEFIT

- Additional, remote fuse box not required
- Time saving
- Cost savings
- Error reduction
- Less space required
- Fewer components

PODIS® DOUBLE OUTPUT

Innovative product design for more flexibility

The module with double output offers the option of operating two consumers with one tap-off. This can save even more time. Basically, this module differs from the standard only in the cover used. This offers a second output at the rear. This cover also offers other options. All variants are described in detail below.

DOUBLE OUTPUT

As described above, this can be used to supply a second consumer. The double output also offers a pluggable RST25 version in addition to the variant with conventional connection. A double wire end ferrule is available for the conventional version, which means that a max. 2x 6 mm² can be connected. We also offer a blank plug for the temporary closure of one side. The RST25 variant is pre-wired at the factory with 2x 6 mm² and only needs to be plugged in with the appropriate RST® cable after connection to the flat cable.

SINGLE OUTPUT

This module does not offer an additional output; instead, the enlarged wiring space provided by this cover can be used as an alternative with a convenient connection with a conductor cross-section of 16 mm².

INTEGRATED TOP-HAT RAIL

This variant also has only one outlet and the increased volume. A top-hat rail is integrated into the module, which provides space for three 18mm modules. An overvoltage protection or an access point, for example, can be integrated on this top-hat rail.



FEATURES

- Second output on the connection module
- Outputs completely pre-wired and pluggable with RST® (6 mm²) or with cable gland
- Flexibility through models with integrated top-hat rail or single input
- Protection rating IP65



YOUR BENEFIT

- One outgoing module can be saved
- Time saving
- Cost savings
- Possibility to integrate DRA (3 DU)

PODIS® CABLE CLIP

Optimized for maximum time savings, increased performance and easy handling.

VARIANTS

We offer two variants, one with an integrated "HILTI" contour for fastening with a bolt gun. The second variant has a slotted hole for classic screw fastening. Only one bolt or screw is required for fastening to the surface.

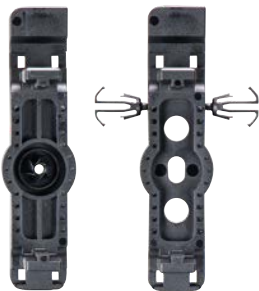

BETTER HEAT DISSIPATION AND EASIER RETROFITTING

The lower section creates clearance between the flat cable and the substrate. The gap allows another connection module to be easily inserted at a later date. Furthermore, this leads to better heat dissipation than direct contact with the substrate.

ONE COMPONENT

The lower and upper sections are connected to each other, which makes assembly (on the ladder) much easier.

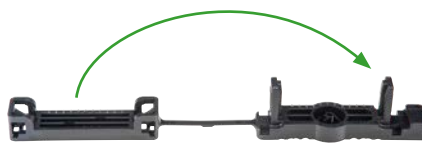

LOCKING WITH QUICK-RELEASE FASTENER

The locking mechanism works without any tools. The upper part is simply pushed down. If the component needs to be opened, this can be done with a simple slotted screwdriver.

CARRYING THE DATA LINE

Any number of pipe clamps can be adapted to the base. In this way, a clean image of the parallel data line routing is realized.



ACCESSORIES

Clips for fastening to cable trays, which are already integrated in the screw version, and a mesh cable tray ("basket"), which can be ordered as a separate accessory, round off the options.



YOUR BENEFIT

- Raised base section offers better heat dissipation and easy retrofitting
- Screw or nail version (bolt gun "HILTI")
- Only one fixing point required
- Only one component: upper and lower part connected to each other
- No tools required for closure

THE SYSTEM WITH 5G25 FLAT CABLE

The podis® 5G16 system can also be used with a 5G25 flat cable. The same components are used as for 5G16 flat cables. A separate component must only be used for the power supply, as

the connection modules are limited to 16 mm². The system can be fused with up to 80 A.

You can find out what you need to consider in our statement (available on request).



CHARGING INFRASTRUCTURE: THE ELEMENTS

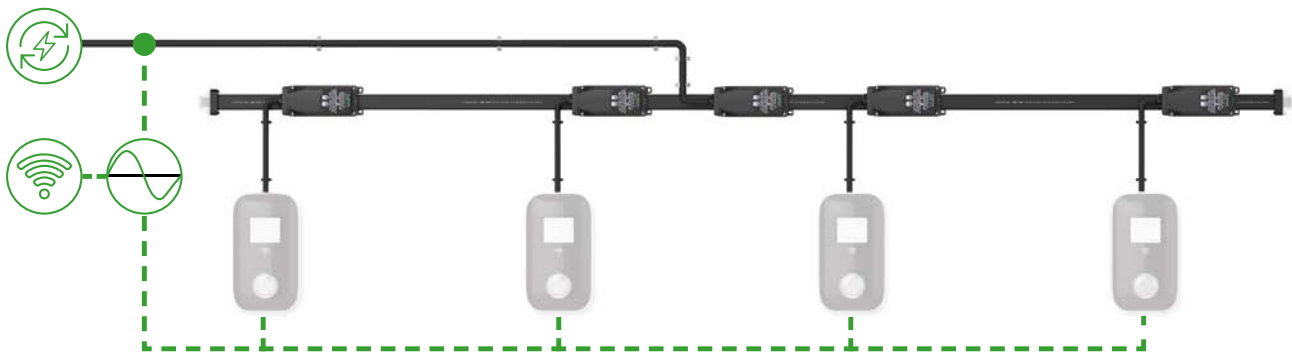

ENERGY SUPPLY

The podis® flat cable system is optimized for charging stations with an alternating current supply and outputs of up to 22 kW.

LOAD MANAGEMENT

Load management is used to distribute the available energy and for phase balancing. You can obtain all information about the options from the manufacturer of your wallbox.

COMMUNICATION

Communication with the wallboxes can - depending on the wallbox - take place parallel to the flat cable or via WLAN.

FIELD OF APPLICATION OF PODIS®

	AC CHARGING	DC CHARGING	INDUCTIVE CHARGING
NORMAL CHARGING	WALLBOX		3.7 KW
			7.4 KW
		10 KW	11 KW
		20 KW	22 KW
FAST CHARGING	44 KW	50 KW	
HIGH POWER CHARGING		150 KW	
		400 KW	

63 A fuse

Charge for ~ 2,800 km

LOAD UP TO **140 km** PER NIGHT WITH PODIS®

Podis® is ideal for distributing energy to charging stations. The connection components for the infeed or the energy tap-off can be placed at any point on the flat cable. The fast and flexible positioning of the connection modules is made possible by the penetration

contacts of the podis® components. The feed into the flat cable can also be freely positioned - even in the middle. This creates an ideal balance of the load on the system and the number of charging stations on a flat cable section can be increased without over-

loading the cable. The tap-off modules are available for fixed installation and also pluggable. This means that extensions and conversions can also be carried out without great effort.

PODIS® INSTALLATION OPTIONS



podis® flat cable system for EV CHARGING

Installation of ev charging stations now available at [YouTube](#) / [WielandElectric](#)

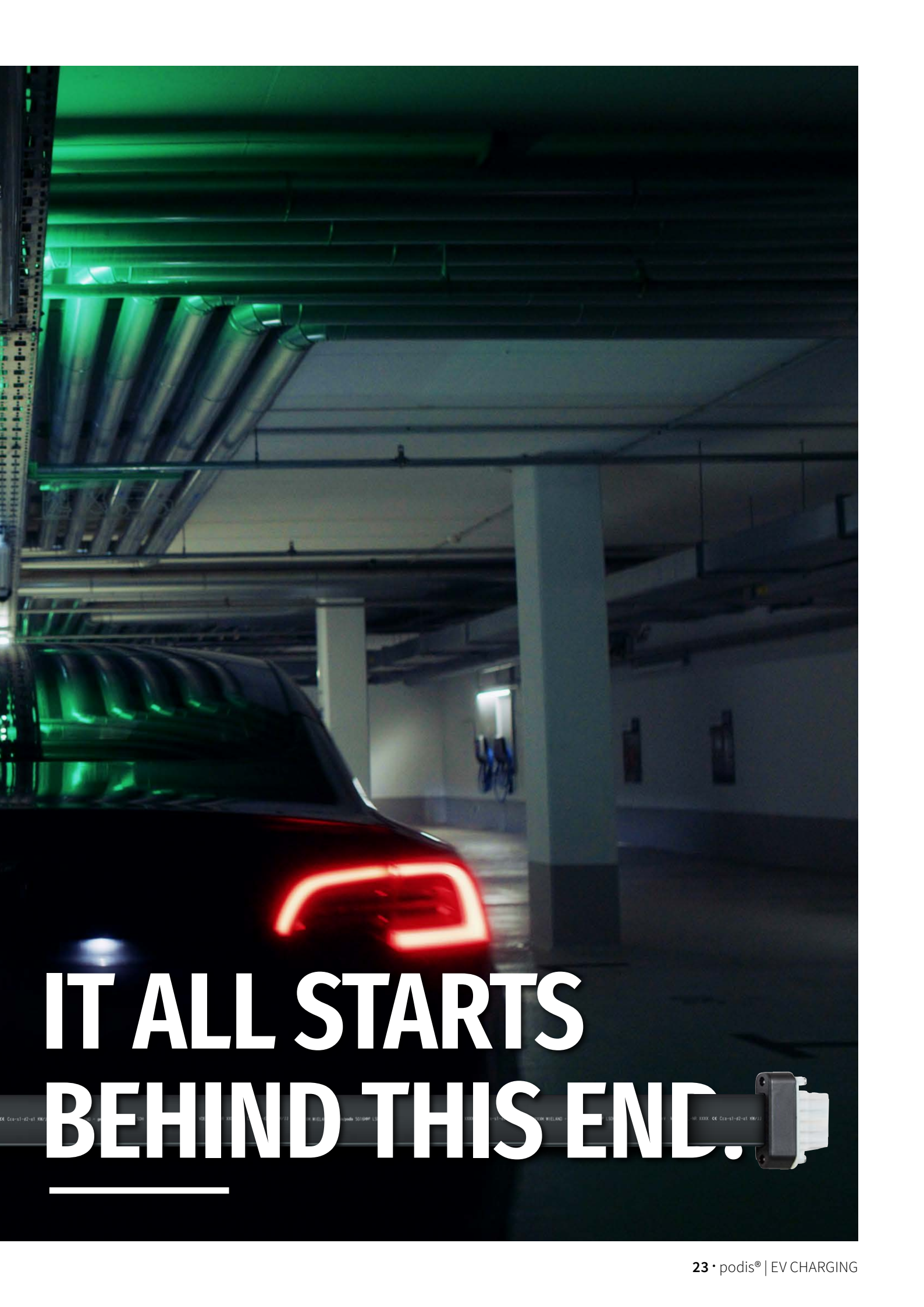

**IT ALL STARTS
BEHIND THIS END.**



ADVANTAGES NON-STOP



No matter in which function - anyone involved in setting up a charging infrastructure will benefit from the numerous advantages of podis®.

INVESTORS

Due to legal regulations, not only new buildings must be equipped with a charging infrastructure, but existing buildings must also be retrofitted in the event of renovation. In both cases, podis® is an inexpensive solution.

- Simple retrofitting in existing buildings
- Can be installed independently of the charging station
- Modern appearance
- Space-saving installation
- Time, money and material-saving system solution

PLANNER

Thanks to maximum flexibility, podis® reduces the planning effort involved in setting up a charging infrastructure to a minimum. Conversion and retrofitting are just as possible as an installation independent of the actual charging station.

- Simple planning thanks to a clear portfolio
- Expandable without major planning effort
- Large number of charging stations possible on one cable section
- Technologically mature
- Reliable operation

IF YOU WANT TO GET FAST ...



ELECTRICIANS

Install more charging stations in less time and react flexibly to your customers' wishes. You benefit in particular from the modular design. Conversions and extensions are therefore possible at any time.

- Can be extended at any point at any time with little effort
- Easy to install
- Saves time, money and material
- Cutting and stripping are not necessary
- Little cabling required
- Low conversion costs

WHOLESALE/ SPECIALIZED TRADE ELECTROMOBILITY

Enhance your portfolio with sophisticated, cutting-edge technology. Installation is extremely straightforward compared to conventional solutions. As a system solution with coordinated components, podis® also simplifies warehousing.

- Complete solution
- Simple warehousing thanks to a clear parts list
- Proof of excellent portfolio
- Technologically mature
- Simple installation as added value
- Can be installed independently of the charging station

CHARGING STATION MANUFACTURER

As a manufacturer of charging stations, you have the option of receiving podis® as a branded complete system. This means that you not only benefit from the sale of your charging stations, but can also offer the installation of the entire charging infrastructure.

- Better customer loyalty through expandability
- Technologically mature
- Reliable operation
- Easy installation
- Installation can also be marketed
- Complete solution

GET A PODIS®.

SMART LOADING, SMART PLANNING: HOW TO CHOOSE YOUR COMPONENTS

EXAMPLE 1

- + 12 charging stations up to 11 kW on one line
- + 63 A Fuse protection of the flat cable
- + 36 m flat cable, black
- + Fastening the cable clips with a bolt gun
- + Protection required for the charging station
- + 1 m distance between flat cable and charging station
- + Pluggability with RST® system desired



E-Shop

View all products of example 1 online!

ITEM.	PART NO.	DESIGNATION	NUMBER	EXPLANATION
1	00.771.0307.1	Flat cable 5G16, black	36 m	36 m correspond to application description
2	05.569.7553.0	Cable clip Nail	45 pcs.	One fixing point per 0.80 m; 36 m / 0.8 m = 45 pcs.
3	Z6.563.6553.0	Cable end cap	2 pcs.	2 pieces per flat cable harness
4	75.456.0053.1	Connection module with cut-out for cable gland	1 pcs	For flexible feeding into the flat cable with up to 16 mm ²
5	Z5.507.1653.1	Cable gland M32 18 - 25 mm	1 pcs	= number pos. 4
6	05.505.0353.1	Locknut M32	1 pcs	= number pos. 4
7	75.456.1155.1	Circuit Breaker Module RST20 (4-pole RCBO type A C16 A / 30 mA)	12 pcs.	= Number of charging stations
8	99.474.0124.0	Connection cable 5G2.5; RST20 1.0 m	12 pcs.	= Number of charging stations

**PICK
AND
DONE.**

THE INNOVATION BEHIND.

Berlin-based electrical company becomes new sales partner for Wieland products

As one of the most innovative electrical companies in Berlin, PaechElektro attaches great importance to reliability and deals with sustainable issues. Electromobility also plays an important role for the company.

In the search for a suitable partner for the efficient implementation of a flexible and safe charging infrastructure in underground parking garages, PaechElektro finally opted for the podis® system from Wieland Electric. Thanks to innovative flat cables and plug-in tap-off modules, the system makes it possible to supply many charging stations with little installation effort and little assembly time. Fast, secure and flexible.

EXAMPLE 2

- + 30 charging stations up to 22 kW on two lines
- + 80 A fuse protection per flat cable run
- + 90 m flat cable 5G25, "dark gray"
- + Fastening the cable clips with a screw
- + Protection required for the charging station
- + 2 m distance between flat cable and charging station
- + Pluggability with RST® system desired



E-Shop

View all products of example 2 online!

ITEM.	PART NO.	DESIGNATION	NUMBER	EXPLANATION
1	99.099.0000.8	Flat cable 5G25, dark gray	90 m	90 m correspond to application description
2	05.569.7453.0	Cable Clip Screw	114 pcs.	One fixing point per 0.80 m; 90 m / 0.8 m ~ 114 pcs.
3	Z6.563.6553.0	Cable end cap	4 pcs.	2 pieces per flat cable harness
4	75.450.0014.3	End feed-in box 35 mm ²	2 pcs.	Only the end feed box can be used for feeding into the flat cable with a 25 mm ² round cable. One end feed box per line = 2 pcs.
7	75.456.1255.1	Circuit Breaker Module RST25 (4-pole RCBO type A C32 A / 30 mA)	30 pcs.	= Number of charging stations
8	99.476.0124.0	Connection cable 5G6; RST25 2.0 m	30 pcs.	= Number of charging stations

The podis® system can be assembled from just a few components and is therefore characterized in particular by its high level of planning reliability. Fast availability also avoids long waiting times.



SUCCESS STORY.



ALL COMPONENTS AT A GLANCE

TECHNICAL DATA OF THE SYSTEM

The **EU & UKCA declarations of conformity** of the PODIS® flat cable system is based on the standards EN IEC 60670-1; EN IEC 60670-22 and EN IEC 60998-1. You can find further approvals for the system in our eShop.

All connection modules and accessories are **UV-resistant** in accordance with EN-ISO 4892 (status 2021-11). The flat cables are UV-resistant in accordance with EN 50618. The hinged covers of the safety modules are not UV-resistant.

The system has **IP protection class 65**.

FLAT CABLES

TECHNICAL DATA	
Rated voltage	690 V
Rated current	63 A
Connector cross section	16 mm ²
No. of poles	5
Impact resistance	IK 10
BPVO class	B2 _{ca} -s1a,d1

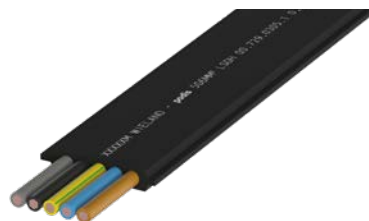

Art. No.	Cross section	Color	Info
00.771.0307.1	5G16	Black, similar to RAL 9005	• B2 _{ca} -s1a,d1,a1
00.771.0307.3	5G16	Gray-white, similar to RAL 9002	• Halogen-free
99.099.0000.8	5G25	Dark gray, similar to RAL 7000	• With CE marking

• **99.099.0000.8:** Special conditions apply for fusing with up to 80 A. Please contact us for more information.

ACCESSORIES



Art. No.	Designation	Info
① Z6.563.6553.0	Cable end cap	for obtaining IP protection
② 05.569.7453.0	Cable clip screw, with quick-locking mechanism	with distance to the substrate, with clips for optional cable tray fastening
③ 05.569.7553.0	Cable clip nail, with quick-locking mechanism	with distance to the substrate, for fastening with bolt gun. Recommended setting tool: "HILTI BX 3-ME"; Recommended nails: "X- B3 MX" (concrete), "X-S B3 MX" (steel)
④ 05.569.7753.0	Clip basket	in combination with 05.569.7453.0 / 05.569.7553.0
⑤ F0.000.0055.7	Pipe clamp D20	for adaptation to 05.569.7453.0 / 05.569.7553.0
⑥ 05.601.2519.0	Cable clip, standard	without distance to the substrate
⑦ 05.601.2419.0	Cable clip with pipe holder	without distance to the substrate, with holder for installation pipe Ø 20 mm

CONNECTION MODULES



TECHNICAL DATA	WITH CABLE SCREW GLAND	PLUGGABLE RST25
Rated voltage	690 V	400V
Rated current	63 A (max. 40°C)	32 A (max. 28°C), see derating curve p.32
Connector cross section	1.5 to 16 mm ²	6 mm ² pre-wired
IP protection class	IP65	IP65
Impact resistance	IK 09	IK 09

Art. No.	Designation	Info
① 75.456.0053.1	Connection module for conventional wiring	with cut-out for M32 cable gland
② 75.453.0053.1	Connection module in plug-in version	with RST25 output, see suitable cables "Pre-assembled cables"

ACCESSORIES

Art. No.	Designation	Info
③ Z5.507.1653.1	M32 cable screw gland	18 - 25 mm
③ Z5.507.1753.1	M32 cable screw gland	10 - 21 mm
④ 05.505.0353.1	Locknut M32	for M32 cable gland
⑤ Z5.565.9853.1	Cover cap RST25	for the temporary closure of the pluggable RST25 connection module

RST® CABLES

Art. No.	Designation	Length
99.456.0124.0	Connection cable 5G6 RST25	0.5 m
99.453.0124.0	Connection cable 5G6 RST25	1.0 m
99.454.0124.0	Connection cable 5G6 RST25	1.5 m
99.455.0124.0	Connection cable 5G6 RST25	2.0 m
99.459.0124.0	Connection cable 5G6 RST25	2.5 m
99.460.0124.0	Connection cable 5G6 RST25	3.0 m



ALL COMPONENTS AT A GLANCE

CIRCUIT BREAKER MODULE



TECHNICAL DATA	WITH CABLE GLAND	PLUGGABLE RST25	PLUGGABLE RST20
Rated voltage	690 V	400V	400V
Rated current	63 A (max. 40°C)	32 A (max. 28°C) s. Derating curve p.32	20 A (max. 28°C) s. Derating curve p.32
Connector cross section	1.5 to 16 mm ²	6 mm ² pre-wired	2.5 mm ² pre-wired
IP protection class	IP65	IP65	IP65
Impact resistance	IK 09	IK 09	IK 09

Art. No.	Designation	Internal device	Output
① 75.456.0955.1	RCBO 32 A M32	4-pole RCBO type A C32 A / 30 mA & SL terminal 6 mm ²	for cable gland M32
② 75.456.0855.1	RCBO 16 A M32	4-pole RCBO type A C16 A / 30 mA & SL terminal 6 mm ²	for cable gland M32
③ 75.456.1255.1	RCBO 32 A RST25	4-pole RCBO type A C32 A / 30 mA	Pluggable with RST25
④ 75.456.1155.1	RCBO 16 A RST20	4-pole RCBO type A C16 A / 30 mA	Pluggable with RST20

Accessories

Art. No.	Designation	Info
Z5.507.1653.1	M32 cable gland	18 - 25 mm
Z5.507.1753.1	M32 cable gland	10 - 21 mm
05.505.0353.1	Locknut M32	for cable glands M32
Z5.565.9853.1	Cover piece RST20/25	for the temporary closure of 75.456.1255.1 and 75.456.1155.1

RST® cables

Art. No.	Designation	Length
99.456.0124.0	Connection cable 5G6 RST25	0.5 m
99.453.0124.0	Connection cable 5G6 RST25	1.0 m
99.454.0124.0	Connection cable 5G6 RST25	1.5 m
99.455.0124.0	Connection cable 5G6 RST25	2.0 m
99.459.0124.0	Connection cable 5G6 RST25	2.5 m
99.460.0124.0	Connection cable 5G6 RST25	3.0 m
99.473.0124.0	Connection cable 5G2.5 RST20	0.5 m
99.474.0124.0	Connection cable 5G2.5 RST20	1.0 m
99.475.0124.0	Connection cable 5G2.5 RST20	1.5 m
99.476.0124.0	Connection cable 5G2.5 RST20	2.0 m
99.477.0124.0	Connection cable 5G2.5 RST20	2.5 m
99.478.0124.0	Connection cable 5G2.5 RST20	3.0 m



DOUBLE OUTPUT MODULES



TECHNICAL DATA	WITH CABLE GLAND	PLUGGABLE RST25
Rated voltage	690 V	400V
Rated current	63 A (max. 40°C)	32 A (max. 28°C), see derating curve p.32
Connector cross section	1.5 to 16 mm ²	6 mm ² pre-wired
IP protection class	IP65	IP65
Impact resistance	IK 09	IK 09

Art. No.	Designation	Info
① 75.456.0353.1	Double output for conventional wiring	2x cut-out for M32 cable gland
② 75.453.0353.1	Double output in pluggable design	2x output RST25, pre-wired
① 75.456.0753.1	Single input / output with break-out for M32	Simple breakout for M32
① 75.456.0553.1	Single input / output with break-out for M32	Integrated top-hat rail and space for 3 dividing units

Accessories

Art. No.	Designation	Info
③ Z5.507.9853.1	Cover piece RST20/25	for the temporary closure of 75.453.0353.1
④ Z5.507.1753.1	M32 cable gland	Clamping range 10 - 21 mm
⑤ 05.505.0353.1	Locknut M32	for cable gland M32 and screw plug M32
⑥ 06.600.7227.6	Twin ferrule DIN 46228	2x 6 mm ²
⑦ 05.506.7453.1	Locking screw M32	for the temporary closure of 75.456.1255.1 and 75.456.1155.1

RST® cables

Art. No.	Designation	Length
99.456.0124.0	Connection cable 5G6 RST25	0.5 m
99.453.0124.0	Connection cable 5G6 RST25	1.0 m
99.454.0124.0	Connection cable 5G6 RST25	1.5 m
99.455.0124.0	Connection cable 5G6 RST25	2.0 m
99.459.0124.0	Connection cable 5G6 RST25	2.5 m
99.460.0124.0	Connection cable 5G6 RST25	3.0 m



OTHER COMPONENTS, ACCESSORIES AND TOOLS



CONVINCE YOURSELF IN ADVANCE NOW!



Sample Case EV Charging

- Flat cable 5G16 & 5G25
- Connection module for the output with cable gland
- Connection module with pluggable output
- A prefabricated cable
- Various mounting options and screw drives

Art. No.	Designation	Description
75.450.0014.3	End feed-in box 35 mm ²	For feeding in at the end of the flat cable with up to 35 mm ² , with cable gland for cables up to Ø 38 mm
75.450.2114.3	End feed-in box 35 mm ²	For feeding in at the end of the flat cable with up to 35 mm ² ; without cable gland, with Ø 25 mm hole
F0.000.0051.9	Cutting tool	
99.789.0000.0	Sample case	All the components you need to connect the podis® flat cable system

DERATING CURVE when using plug-in module variants

RST25i5 (screw connection) Derating curve to IEC 61984 Edition 2 dated 10/2008 Para. 7.3.8

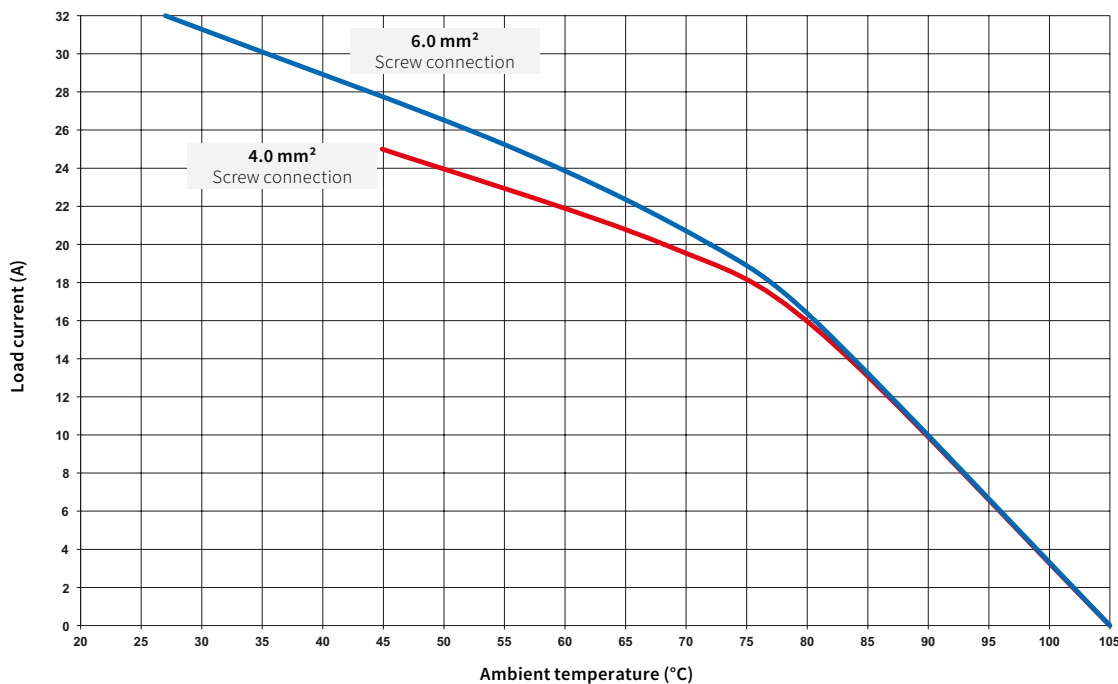



QUALITY THAT **SIMPLY CONVINCES**

What could be more convincing than enthusiastic customers? Read here why the Swiss Burkhalter Group fully relies on podis®.



INFO

Burkhalter Group

The Burkhalter Group is the leading provider of electrical engineering services for buildings and is represented by almost 50 Group companies at over 100 locations in Switzerland. The entire range of services is realized in high quality and precise execution: Installations, switch-gear, service and maintenance, telematics, automation and security.

www.burkhalter.ch

SIMPLE SOLUTION FOR THE DISTRIBUTION OF ELECTRICAL ENERGY

Time is money, even when implementing electrical installations. Daniel Ruf from Burkhalter Management AG knows this too. The company is now realizing the development infrastructure for charging stations throughout Switzerland, including for many large property owners. "We rely on a system that can be installed with little effort and without errors. Traditional cabling methods would no longer work with our business model." In the Eigengr-

"We rely on a system that can be installed with little effort and without errors."

DANIEL RUF

Burkhalter Management AG

und housing cooperative development on Letzigraben in Zurich, Burkhalter prepared around 90 parking spaces with a flat cable system from Wieland Electric AG and also installed some of the charging stations. The great advantage of bus-style cabling of the charging stations also comes into play when retrofitting in existing underground garages, especially when implementing the access lines. A flat cable system reduces their number enormously because only a few supply lines need to be laid or installed up to the main distribution board. In addition, fewer fuse elements and possibly also fewer RCDs are required in the distribution board. Their installation is not always easy, especially when retrofitting. "Let's imagine that we install 90 charging stations in an underground car park and want to do this with conventional cables and junction boxes... that would be an adventurous undertaking in many places. In all the projects that we retrofit, the space available in the route and in the main distribution board



They have already implemented several charging infrastructure projects together: from left to right Daniel Ruf, Burkhalter Management AG, Reto Ruf, Wieland Electric AG, and Florian Kienzle, Novavolt AG

is not exactly princely. Of course, a system like this suits us very well. The development from the main electrical distribution board to the flat cable has proven to be very feasible in most cases," adds Daniel Ruf. And indeed, a closer look at the installations and the existing route reveals that, thanks to the different access routes, only relatively few cables had to be laid and this was also very easy to do at a later date.

WORLD OF WIELAND

Further information and Wieland Electric brochures for download can be found on our Website:

<https://www.wieland-electric.com/en/support/downloads/>



SMART CHARGING.

The power bus system for supplying charging stations.

Bestell-Nr. 0840.1



PODIS®PLAN

The project planning tool for energy-related design of your specific electrotechnical configuration of flat cables.



 / **WielandElectric**
Watch our solutions in action



<https://www.youtube.com/user/WielandElectric>



Technical advice:
Building Solutions

E-mail: building@wieland-electric.com

Worldwide: <https://wie.li/contactinternational>

GO SHOPPING

<https://eshop.wieland-electric.com>

Our Wieland E-Shop:

More than 25.000 Produkte – anytime.

In our online store you will find all the information about our products, prices, and technical data.

Order easily and conveniently online, and check availability.



**SCAN IT
FIND IT
BUY IT**



wieland

HEADQUARTERS

Wieland Electric GmbH
Brennerstraße 10 – 14
96052 Bamberg · Germany

Phone +49 951 9324-0
Fax +49 951 9324-198
info@wieland-electric.com

**THE
INNO
VATION
BEHIND**

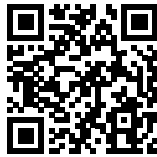

0438.1 S 02/24

Represented in over 70 countries worldwide:
www.wieland-electric.com