



1945 - 2015

70
Years

Superior Clamping and Gripping

SCHUNK 

PRISMO3
Mechanical
Tool Grinding Toolholder

Saves up to 70% in conversion costs

PRISMO3 Mechanical Tool Grinding Toolholder

Saves up to 70% in conversion costs

SCHUNK PRISMO3 saves you conversion time in the automated grinding of drilling, reaming and milling tools. This patented grinding toolholder enables direct and uninterrupted clamping for a shank diameter range of 3 to 20 mm without having to use intermediate sleeves or collets.

The benefit for you: for the first time, different shank diameters can be loaded with high precision during multiple-shift operation without an operator.

The self-centering clamping function and the hard-coated chuck jaws of the PRISMO3 ensure consistent repeat accuracy and enable a constant and process-reliable clamping position.

At the same time, the clamping function guarantees that the clamping device is always exactly adapted to the specific tool diameter. Regardless of the diameter, the tool is centered by the chuck jaws each time with high precision.

PRISMO3 is the highly versatile, process-reliable toolholder for diverse applications in automated tool grinding. Compared to conventional collets or high quality toolholders in the automated grinding business, PRISMO3 guarantees process-reliable and consistently precise run-out. At the same time as providing axial stability, the minimal interfering contour results in an ideal interference between grinding wheel for optimal grinding and sharpening.

Closed
chuck jaws



Open
chuck jaws



The benefits at a glance

More flexible	Clamping diameters between 3 and 20 mm ; can be clamped flexibly
More efficient	Set-up cost savings up to 70% because no conversion necessary
More secure	Low-wear and process-reliable due to hard-coated chuck jaws
More adaptable	24 hours/day automated loading. Unmanned due to versatile loading possibilities of different shank diameters
More precise	Permanently high run-out accuracy < 0.010 mm* for precise results
More stable	Constant, process-reliable clamping position avoids X axis displacement and axial run-out

* for an unclamped length of max. 45 mm across the entire clamping range at max. clamping force.
Higher run-out accuracy can be guaranteed for adjusted process conditions.

Compatibility guaranteed

The mechanical PRISM03 tool grinding toolholder has all the prerequisites for high-precision and economical tool grinding on the machines of all renowned manufacturers. It is more versatile and effective, which is why many machine manufacturers and equippers choose it for chaotic loading without an operator.

SCHUNK offers advice on the interface requirements as well as in terms of loading when the aim is to guarantee reliable precision in your production process.

The functional principle

Clamping range of 3 mm ...

After using the tool, the clamping sleeve is retracted. The chuck jaws close, the tool shank is clamped under tension independently of the diameter. The axial position remains unchanged.

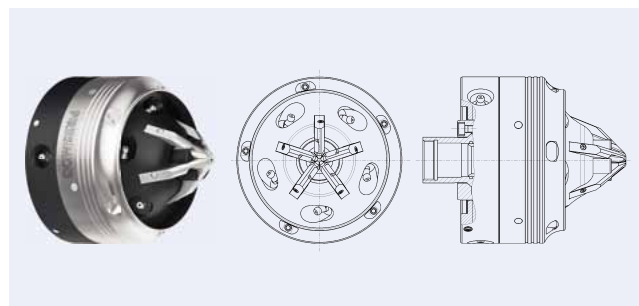

... to 20 mm

The functional principle of the PRISM03 is based on a high-precision clamping sleeve with guidance. It is pushed completely forward after each clamping cycle. The chuck jaws open for a maximum diameter up to 20 mm.

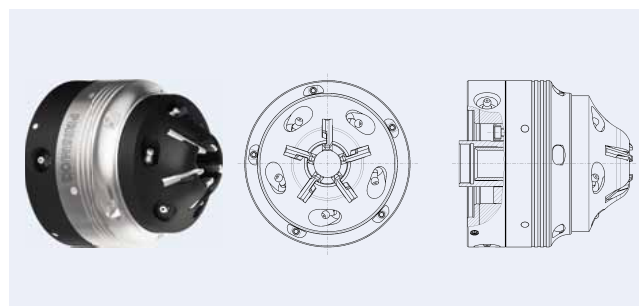

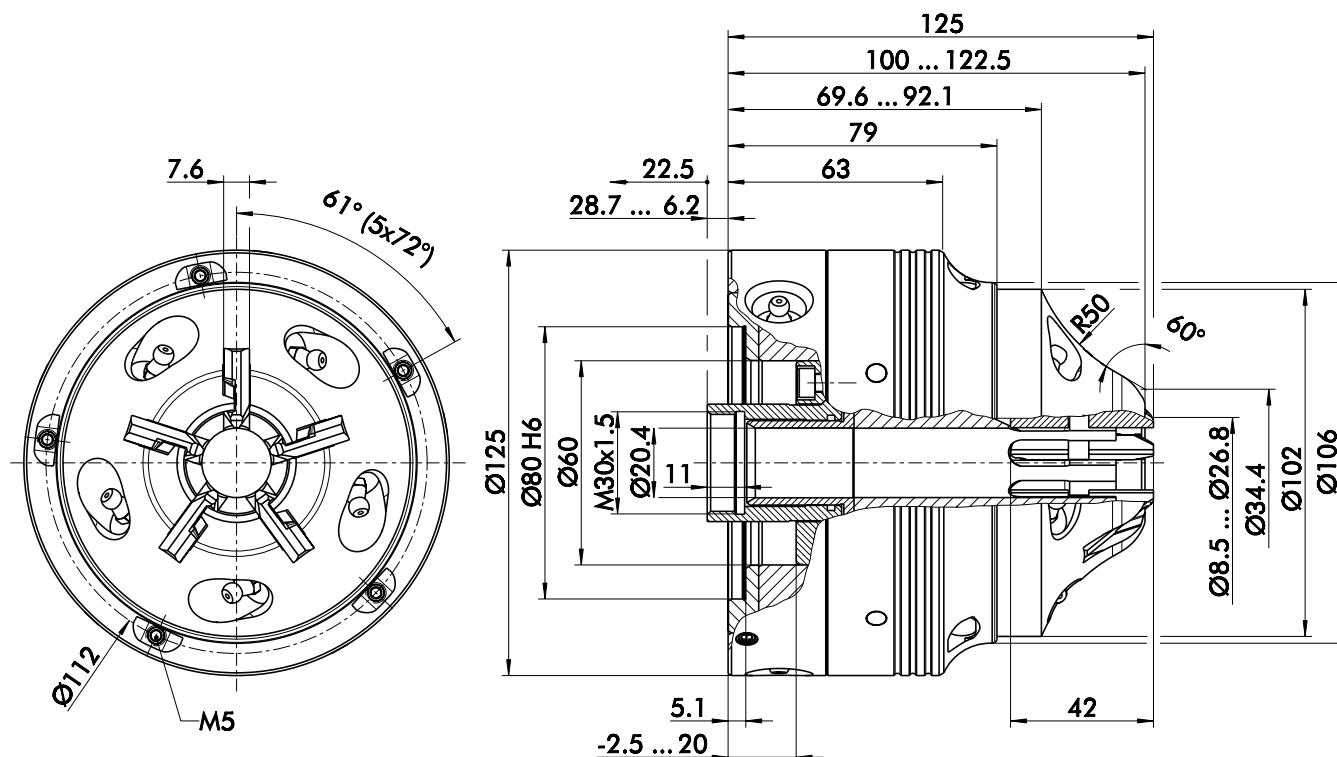

Designation	ID	ID
PRISMO3 $\varnothing 3 - \varnothing 20$	0206601	0206602
Clamping \varnothing position "Closed"	[mm] 3.0	3.0
Clamping \varnothing position "Open"	[mm] 20.0	20.0
Front \varnothing piston	[mm] 34.4	34.4
Outer dimensions	[mm] $\varnothing 125.0$	$\varnothing 125.0$
Centering \varnothing	[mm] 80 H6	80 H6
Bolt circle for mounting	[mm] 112.0/M5	112.0/M5
Chuck length	[mm] 125	125
Base body length	[mm] 79.0	79.0
Centering length	[mm] 5.0	5.0
Stroke per jaw	[mm] 8.5	8.5
Piston stroke	[mm] 22.5	22.5
Run-out accuracy	[μ m] < 10*	< 10*
Repeat accuracy	[μ m] < 5	< 5
Through-hole	[mm] $\varnothing 20.4$	$\varnothing 20.4$
Clamping length	[mm] 42.0	42.0
Max. actuating force	[kN] 10.0	10.0
Max. clamping force	[kN] 12.5	12.5
Max. speed	[rpm] 2,500	2,500
Weight	[kg] 6.4	6.4
Thread	M30x1.5/internal thread	M32x1.5/external thread

* for an unclamped length of max. 45 mm across the entire clamping range at max. clamping force.
Higher run-out accuracy can be guaranteed for adjusted process conditions.

Specifications and illustrations are nonbinding and only represent an approximate description.

We reserve the right to make changes to the product delivered compared to the specifications and illustrations, e.g. with regard to technical data, design, equipment, material and exterior appearance.



Automated Workpiece Change

Efficient and process reliable with SCHUNK

Automated Workpiece Change – efficient and process reliable with SCHUNK

Process-reliable, precise, space-saving workpiece change plays a crucial role during automated grinding operation. You have the choice between a robot and an axis system.

SCHUNK provides the right front-end solution for every robot and every machine situation. Our robot accessories guarantee optimum coordination between the robot arm and SCHUNK gripper – precise and process reliable.

Our linear module performance range offers an alternative to robots. SCHUNK axis system solutions give you new perspectives for cost-efficient, productive automation as a result of our end-of-arm competence.

SCHUNK Robot Accessories

SCHUNK robot accessories comprise the world's most extensive range of modules for mechanical, sensoric, and power connection between effectors and robots. Various quick-change systems, rotary feed-throughs, anti-collision devices, and overload protection, force sensors as well as compensation units and insertion units guarantee perfect interaction between the robot arm and the end-of-arm effector.

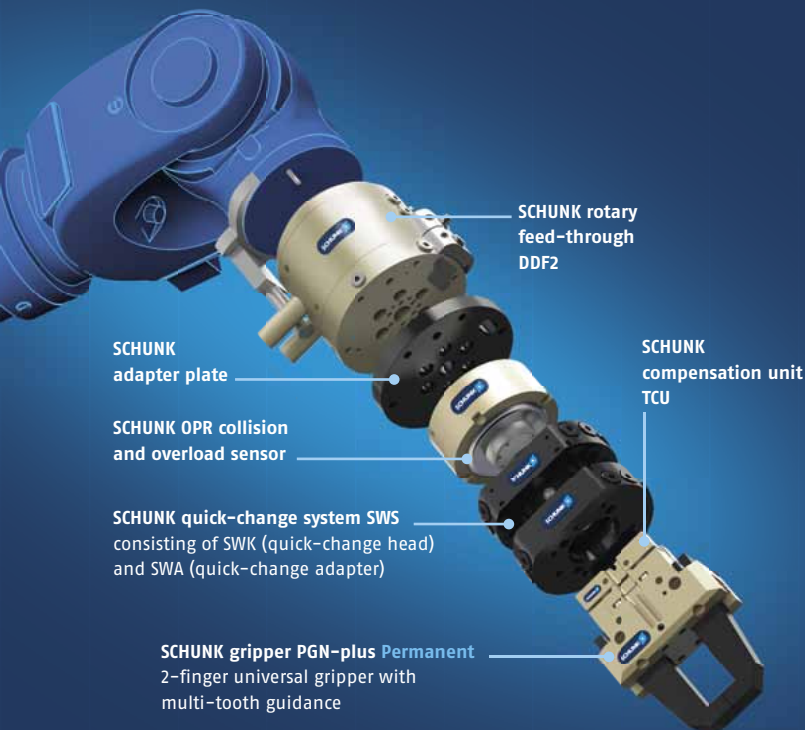

SCHUNK Axis System

The SCHUNK standard range of gantries optimally covers the most common handling tasks. You can put together the gantry you desire simply and reliably from a choice of over 500 combination options on the basis of your pre-defined parameters or process specifications. If additional modifications are required, SCHUNK will be pleased to develop an individual solution for you.

Jens Lehmann, German goalkeeper legend, SCHUNK brand ambassador since 2012 for precise gripping and safe holding.
www.gb.schunk.com/Lehmann



SCHUNK GmbH & Co. KG
Spann- und Greiftechnik

Bahnhofstr. 106 – 134
D-74348 Lauffen/Neckar, Germany
Tel. +49-7133-103-2599
Fax +49-7133-103-2239

spanntechnik@de.schunk.com
www.schunk.com

 www.youtube.com/SCHUNKHQ
 www.twitter.com/SCHUNK_HQ
 www.facebook.com/SCHUNK.HQ



Reg. No. 003496 QM08