





Vaculex TP løfter

Vaculex TP løfter er meget alsidig og håndterer et stort udvalg af varer i forskellig størrelse, form og vægt. Den griber varerne fra enhver side, og man kan nemt rotere enten liftten eller varerne 360° for at placere dem efter behov. Liftten kræver minimal træning for at bruge. Maks vægten er 40 kg som standard, men kan øges til 65 kg. Vaculex TP-familien omfatter TPH, TP Scale, TP BaggageLift og TP Combi.





ALWAYS IN MOVEMENT





Vaculex VL løfter

Vaculex VL er den brugervenlige og kraftfulde løfter. Den anvendes hovedsageligt hvor behovet for løft af tungere varer er almindeligt. Løfteren anvendes med begge hænder. Vaculex VL kan løfte næsten alt mellem 30 og 250 kg. og med den rigtige kombination af tilbehør kan Vaculex VL løfte flere genstande på en gang, vippe og dreje varer.



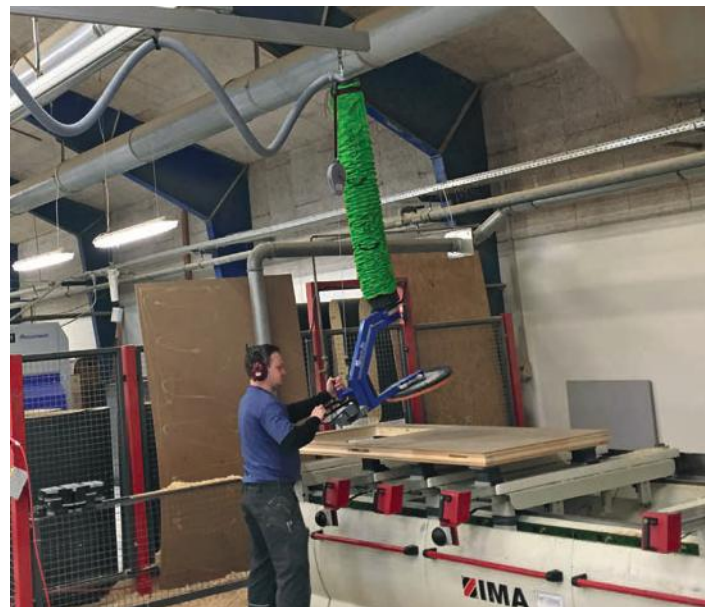
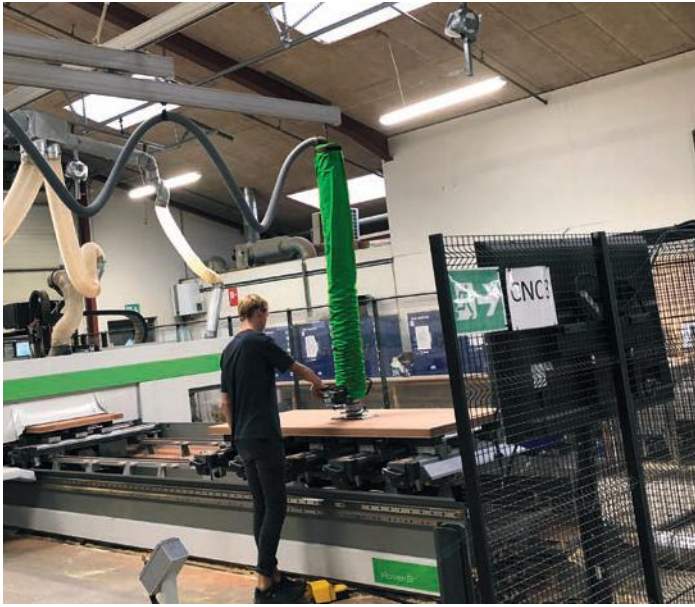

ALWAYS IN MOVEMENT





Vaculex ML

Vaculex ML er en håndbetjent vakuumløfter, som let kan tilpasses til de fleste håndteringssituationer med løft på mellem 5 og 70 kg. ML-serien tilbyder mange muligheder for at vælge mellem forskellige styrehåndtag, sugefødder og andre løsninger for at tilpasse løftesystemet til dit specifikke løftekrav.





Vaculex TS

Vaculex TS er udviklet til at løse problemer med håndtering af varer mellem lave og høje stablingshøjder.

Vaculex TS gør det nemt at gribe eller frigive varer med høj kontrol selv ved højder langt over operatørens hoved.

Det unikke design af Vaculex TS styrehåndtag gør det også muligt at løfte varer på gulvniveau uden at man skal bukke eller bøje sig.

Vaculex TS kan let tilpasses specifikke behov. Styrestangsprincippet for stabling kan også benyttes på Vaculex VL-produktserien.



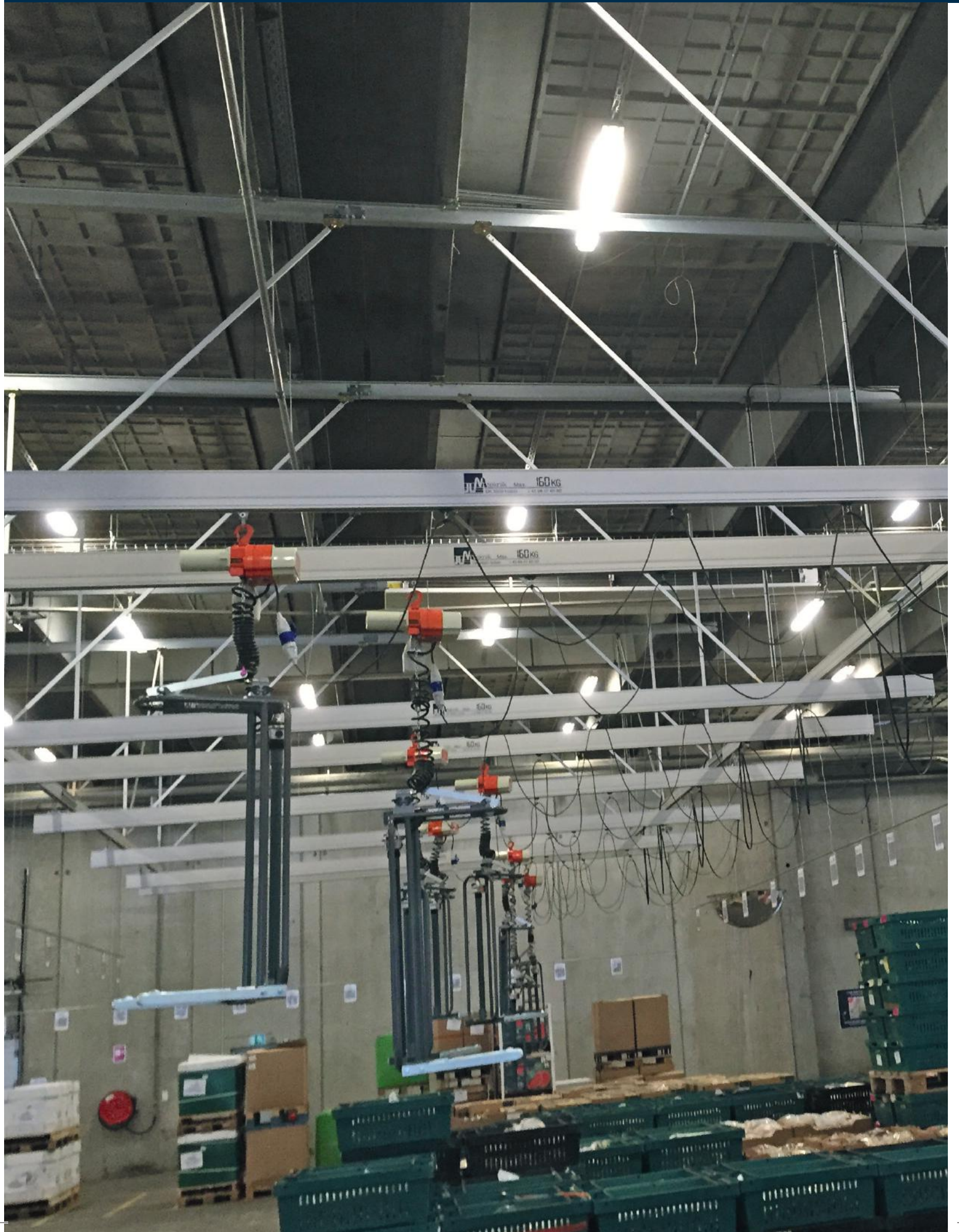

Letløbende aluminiumskinne anlæg

Krananlæg til meget let bevægelse i x-y retning.

Utrolig let montering i loft/spær eller på søjler.

Perfekt til enten vakuumløftere eller talje.

Nem at udvide i længderetning.

JLM giver op til 5 års garanti på anlægget.

JLM har forskellige skinne størrelser, der dækker fra få kilo og op til 1000kg. ved 5m spænd.



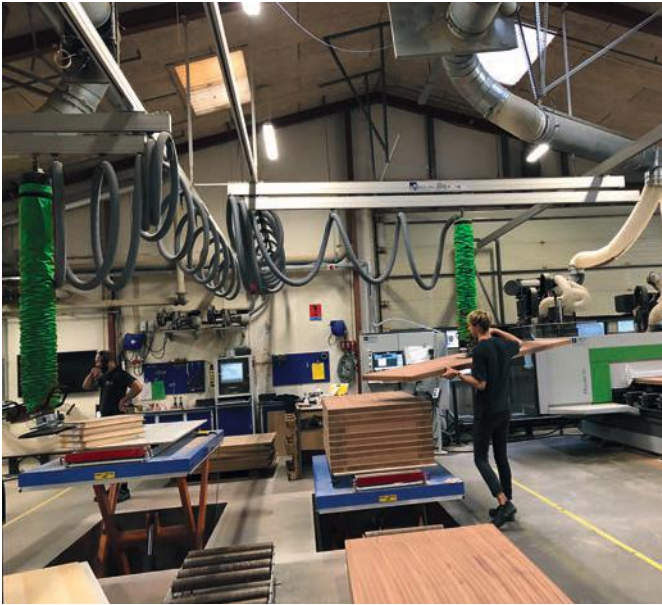

ALWAYS IN MOVEMENT



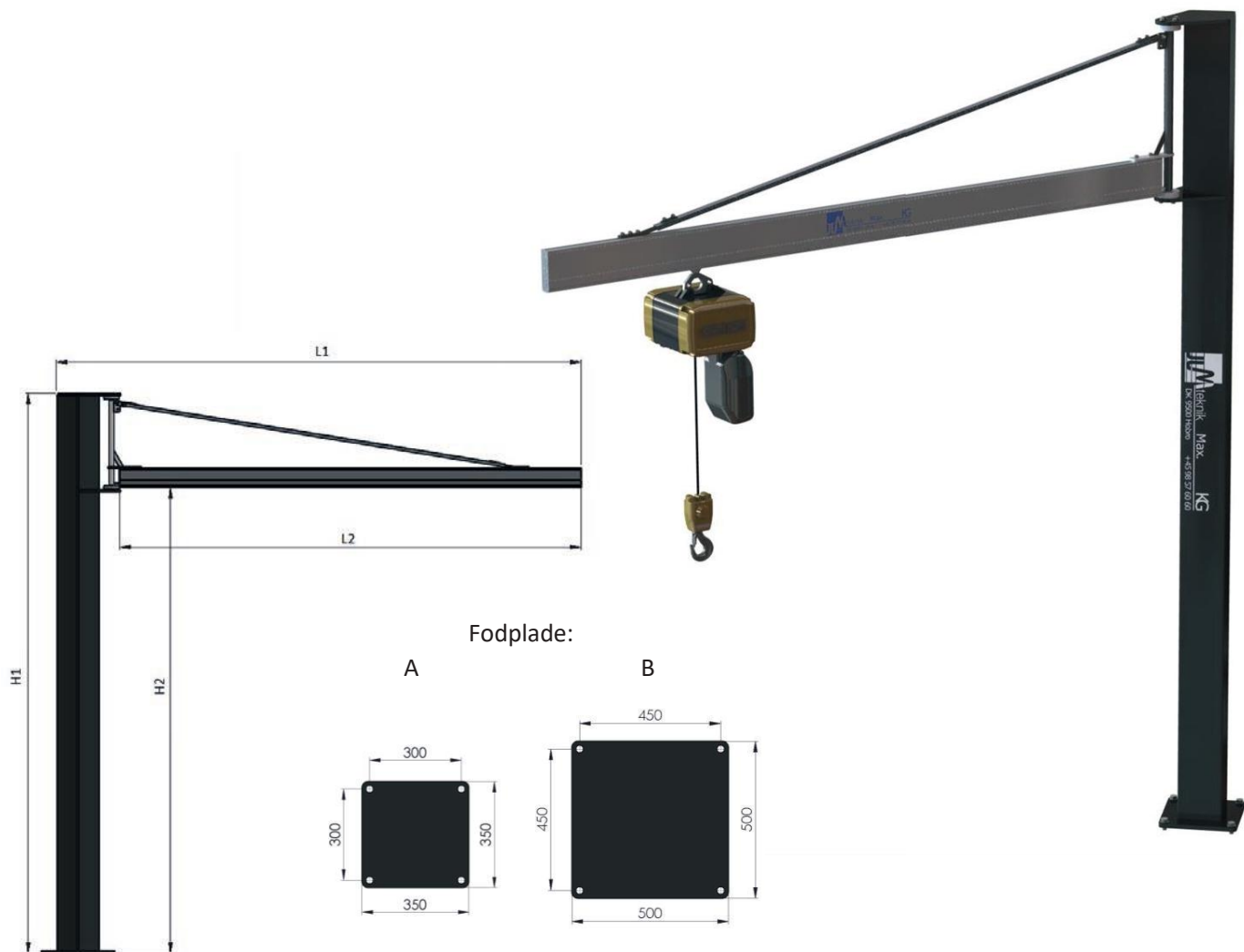

Type	Løftekapacitet	Totallængde (L1)	Skinnelængde (L2)	Svingområde	Højde (H1)	Højde til skinne (H2)	Type af fodplade
SL2KG125	125 kg	2415 mm	2000 mm	270°	3635 mm	3000 mm	A
SL3KG125	125 kg	3415 mm	3000 mm	270°	3635 mm	3000 mm	A
SL4KG125	125 kg	4415 mm	4000 mm	270°	3635 mm	3000 mm	A
SL5KG125	125 kg	5415 mm	5000 mm	270°	3635 mm	3000 mm	A
SL3KG160	160 kg	3415 mm	3000 mm	270°	3635 mm	3000 mm	A
SL4KG160	160 kg	4415 mm	4000 mm	270°	3635 mm	3000 mm	A
SL5KG160	160 kg	5415 mm	5000 mm	270°	3635 mm	3000 mm	A
SL3KG250	250 kg	3415 mm	3000 mm	270°	3635 mm	3000 mm	A
SL4KG250	250 kg	4415 mm	4000 mm	270°	3635 mm	3000 mm	A
SL3KG320	320 kg	3415 mm	3000 mm	270°	3785 mm	3000 mm	B
SL4KG320	320 kg	4415 mm	4000 mm	270°	3785 mm	3000 mm	B

Søjlesvingkran

Søjlesvingkran med aluminiumsudlægger arm, for montering af talje eller vakuumløfter.

Løftkapacitet op til 500kg.

Kan monteres i gulv eller på flytbart fundament.





Flytbar vakuumløfter 'Empty'

Flytbar søjlesvingkran med Vaculex vakuumløfter.

Svingarmen er knækarm max. 2,4m.

Søjlen er med hæve/sænkefunktion.

Kan flyttes med gaffeltruck.

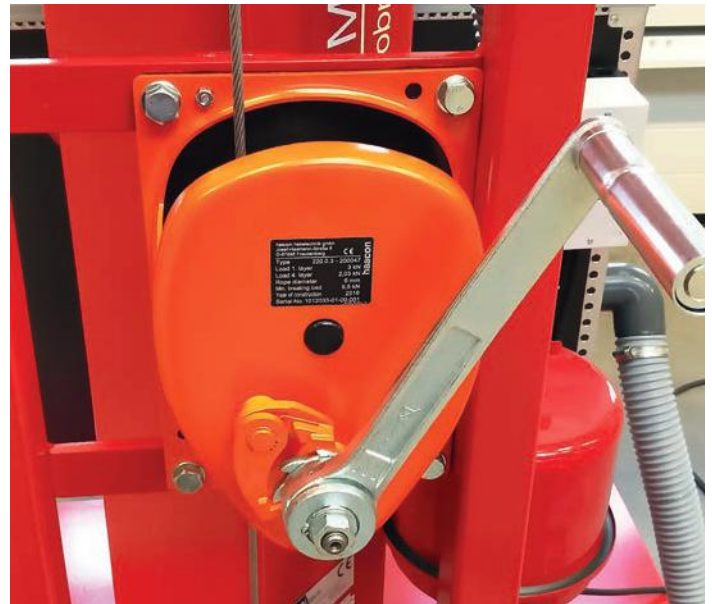
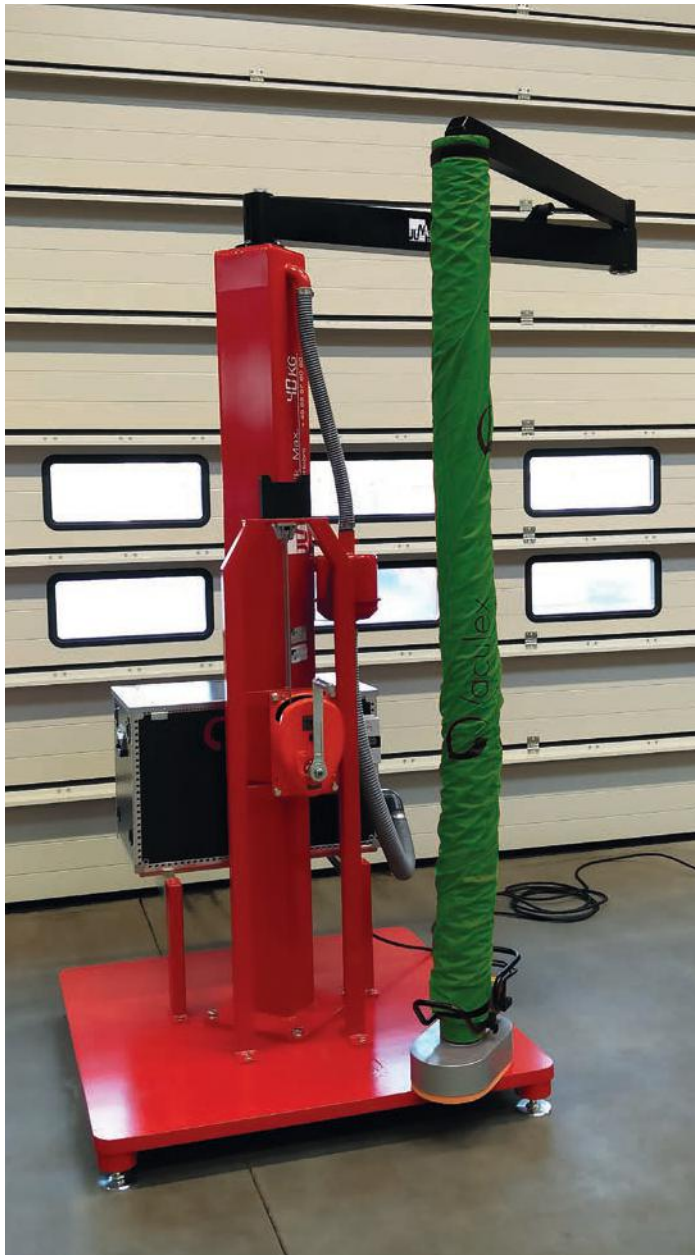



Freja/Containertømmer

JLM mobil containertømmer. Kan kobles på de fleste transportbånd.





Thor/containertømmer

JLM eldrevet containertømmer. Med eldrevet bånd hvor der kan tilkobles rullebånd i forlængelse.





ODIN/containertømmer

JLM eldrevet containertømmer hvor der tømmes direkte på palle.

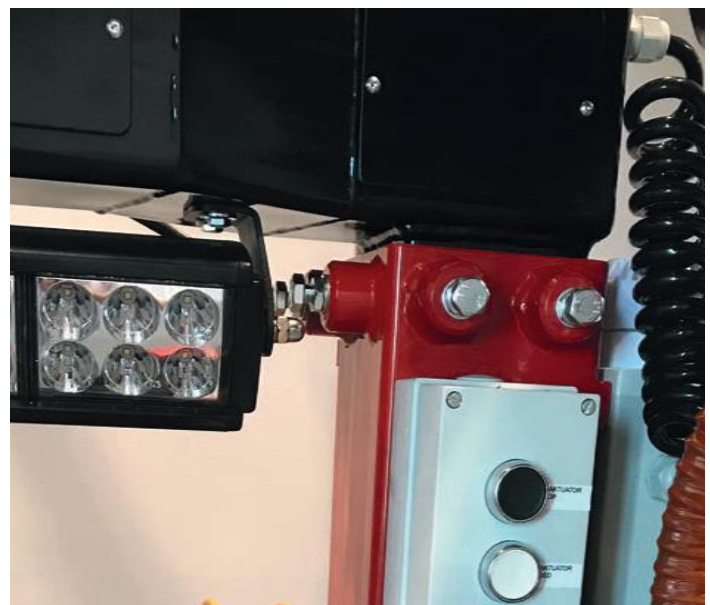

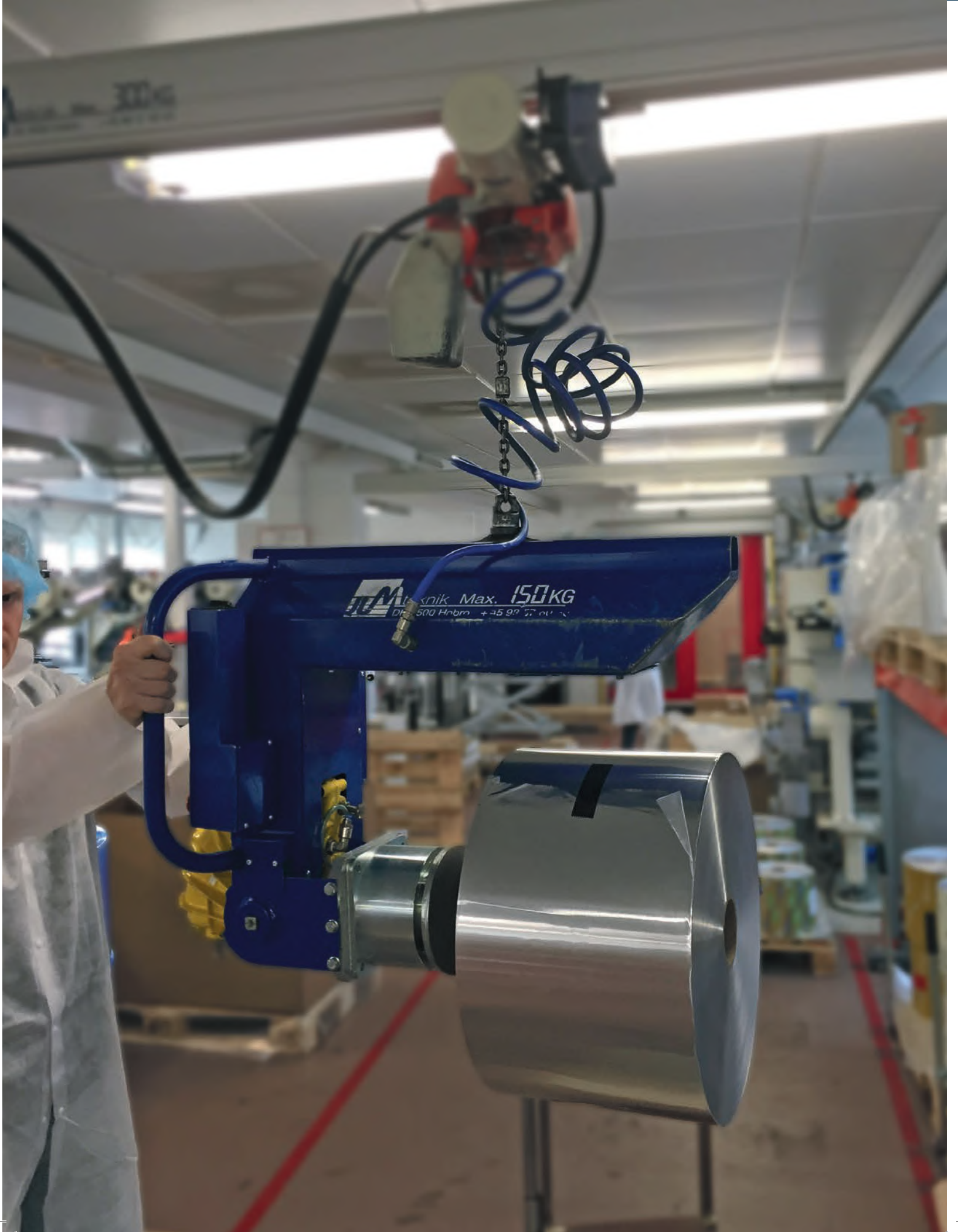

Folierulleløfter med 90° tilt

Folierulleløfteren fastholder med dorn, i den indvendige diameter og kan tilte rollen 90° med luftcylinder. Der er automatisk tyngdepunkts forskydning når der tiltes.

Det forudsætter, at rullen ikke laver spiraleffekt ved løft i indvendig core.

Bemærk billede er ikke et standard åg, men er vist med 3" og 6" dorn.

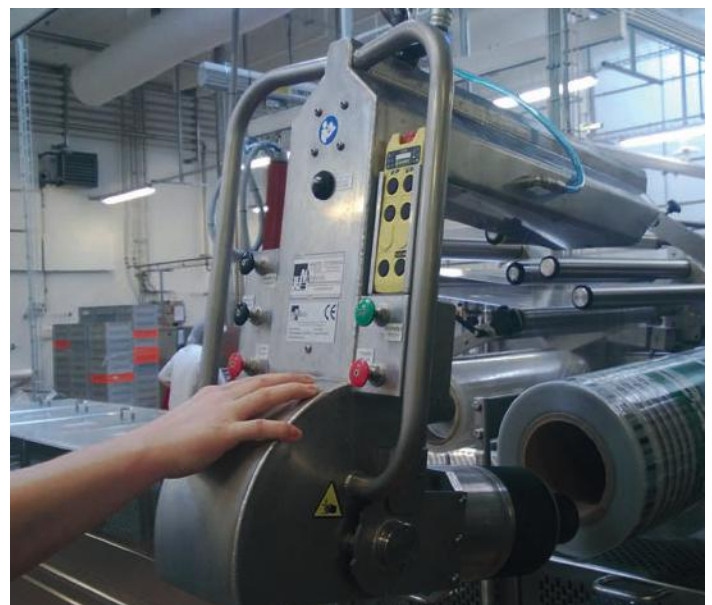
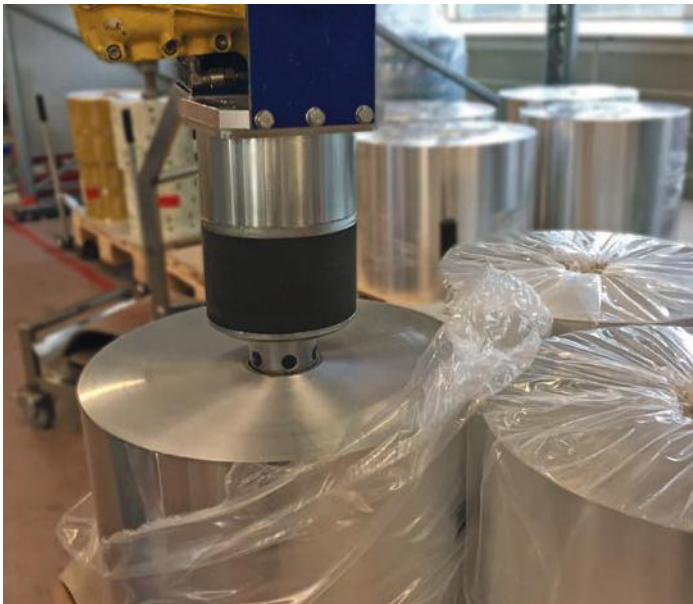



180° vendeålg

Løfteålg med 180° tilt. Til løft af materialer med glat overflade og hvor der ikke er gennemsug. Eks. jernplader, glas, plast mm.

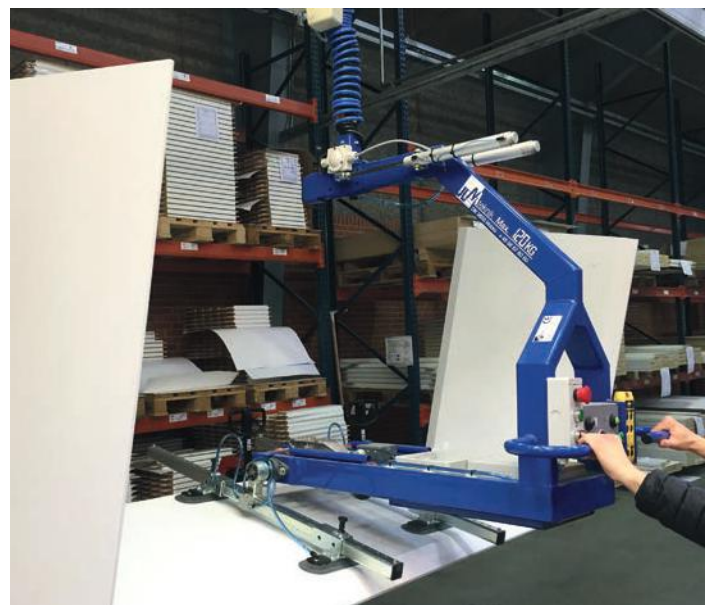
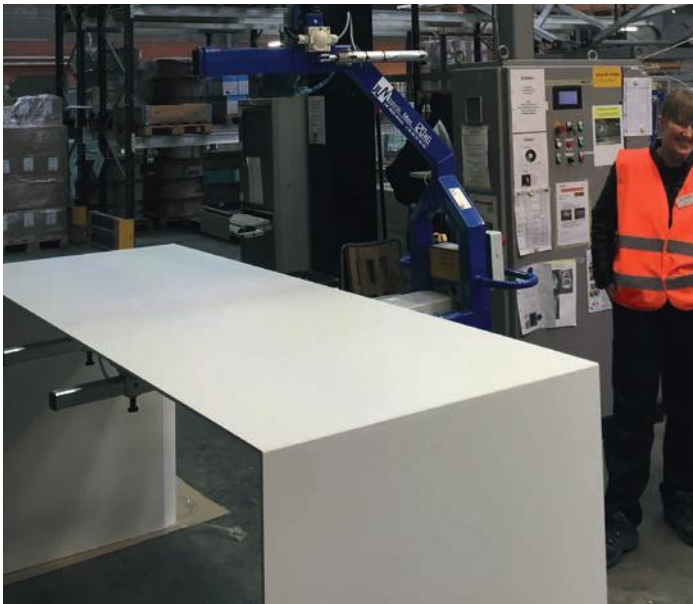



Pladeløfteåg

Pladeløfteåg fås i tre forskellige varianter op til 1000kg.

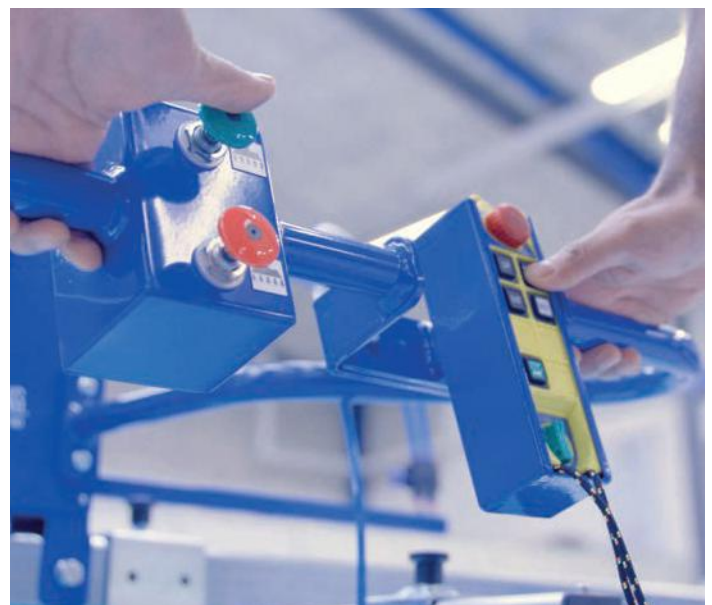
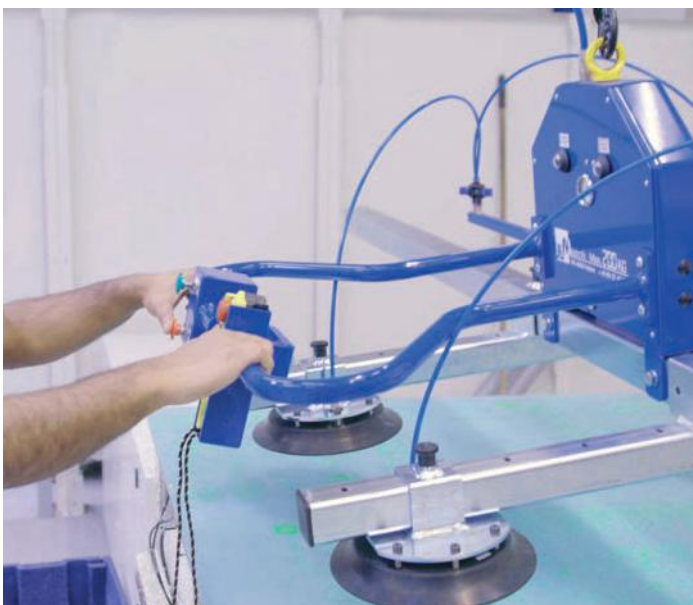
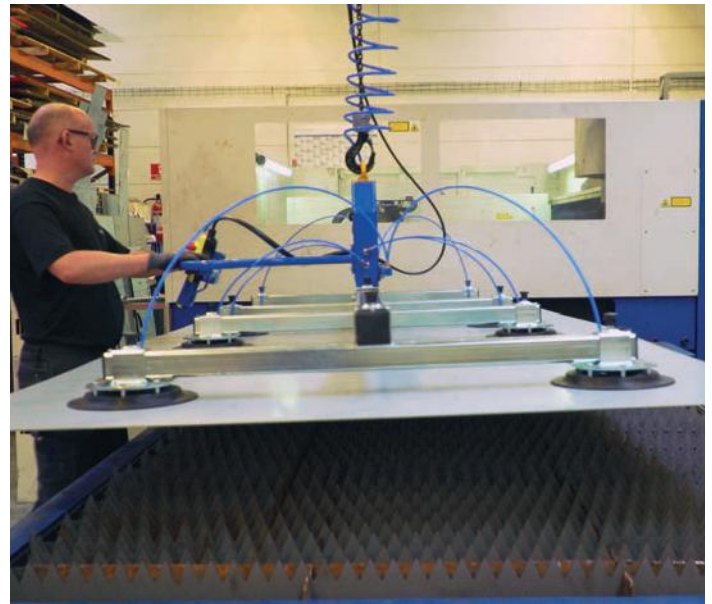



Krone Løfteåg

Løfteåg til løft af glas eller vinduer.

Kan rotere 90° til begge sider manuelt. Maks 500kg.

Vi har flere forskellige løfteåg til glas og vinduer, venligst kontakt os for information.

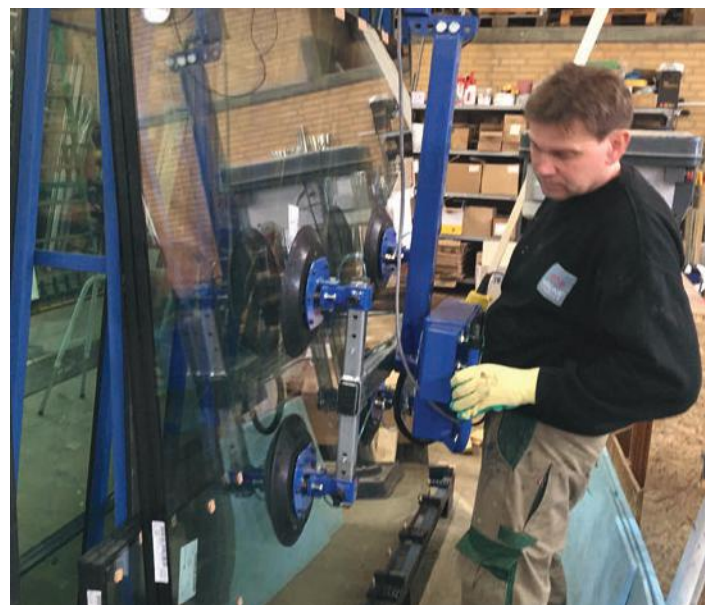



Sakseåg (Klik klak)

Speciel fremstillet sakseåg, der klemmer udvendigt på emnet, når der løftes med talje.

Bemærk billede er ikke et standard åg





Løft af kasser på lager

Løsninger for løft eller pluk af kasser på lager.





newton[®] REFLEX

Ergonomic, versatile and reliable

Newton is the perfect combination of ergonomics, safety and functional design. The lifting mechanism and cables are well protected, and the simple operating device is positioned at a convenient working height. Rounded shapes and high-quality material make Newton versatile to manoeuvre and easy to keep clean.

The Reflex lifters have been specially designed to withstand tough tasks in all kinds of environments. The Reflex models are made of stainless steel and particularly resistant to chemicals.



**LIFTING TROLLEY
NEWTON 50**

The smallest, but yet robust lifting trolley for handling goods up to 50 kg. Very suitable for lifting assistance in tight spaces.



**LIFTING TROLLEY
NEWTON 70**

Designed on the basis of professional demands for versatility and function. A small but sturdy lifter that is simple to use for loads of up to 70 kg.



**LIFTING TROLLEY
NEWTON 100**

Working efficiently involves working safely and comfortably. Use the Newton 100 to handle goods weighing up to 100 kg.



**LIFTING TROLLEY
NEWTON 150**

Need to lift even more? Then have a look at the Newton 150 – a versatile and reliable lifter suitable for most industries and environments.



**LIFTING TROLLEY
NEWTON 250**

For the really heavy goods, our efficient Newton 250 is really a helpful lifter. Lifts a lot, but still manageable.



**LIFTING TROLLEY
REFLEX 200**

A powerful unit for quick lifts of up to 200 kg. And completely stainless.



**LIFTING TROLLEY
REFLEX 75 STAINLESS IP 54**

The stainless steel version for more demanding environments! Safety class IP 54. Lifts up to 75 kg.



ROLLTURNER

An expander for turning rolls of material back and forth between vertical and horizontal positions.



MILK PLATFORM

Simple and convenient handling in the kitchen. Easily lifts 20-litre packs of milk for instance.



STAINLESS STEEL PANEL

A removable stainless steel panel can easily replace the standard plastic platform.



FOLD-AWAY PLATFORM

A combination of a fold-away platform and a fork for canteens or trays, for example, greatly expanding the area of use of the lifter.



FORK

A versatile unit for both pallets and cylindrical objects.



SINGLE BAR

Rolls, tyres, sacks ... Lifts everything with a hole or a hook.



GRIP AND ROTATE UNIT

Lifts and turns large buckets, gas cylinders and other cylindrical items.



V-BLOCK FOR ROLLS

The V-block is ideal for safely handling rolls of material. The block can also be rotated to different positions.



PALLET

Profiled and corrugated loading pane of 3 mm aluminium. Full pallets can be dealt with from all four sides by the truck. Half pallets are lifted from the long side. The recommended max. load for a full pallet is 1,500 kg from the floor and 1,000 kg when stacked.



ALWAYS IN MOVEMENT





JLM teknik
Erhvervsparken 2, 9500 Hobro
Tlf: +45 9857 6060
info@jlmteknik.dk

www.jlmteknik.dk