

asfalq
TOOLS

● LIFTING MAGNETS

● MAGNASLOT

● MAGNETIC TOOLS

asfalq
MAGNETS

asfalq
MACHINES

● CLAMPING MAGNETS

Magnetic tools

welding, separating, holding, clamping, demagnetizing

for work-relieve,
time saving and safety.

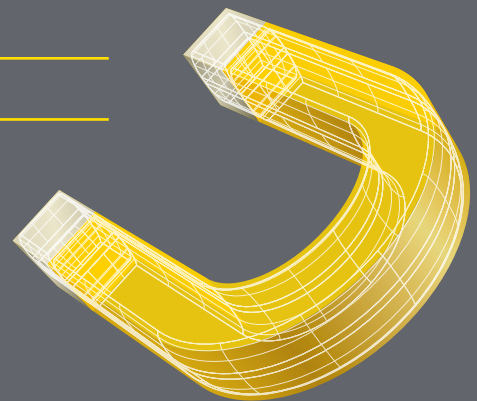

The Ace for Metal

MAGNETS MACHINES TOOLS

Assfalg GmbH

Buchstraße 149
73525 Schwäbisch Gmünd
Germany

Phone +49 (0) 71 71 92 505-0

Fax +49 (0) 71 71 92 505-50

info@assfalg-metal.com

www.assfalg-metal.com

The right of changes and deviating pictures is reserved. Liability is excluded.

Design and production:
Hela Werbung GmbH | www.hela.com



Magnetic Welding Tools



MSQ Magsquare | MagWheel | MagMount 04
Workholding Tool



Ground Magnets 09
Magnetic Ground Clamps



A 90 | BA | MS2 05
Magnetic Welding Angles



MSA | MS | MAV | PA | SW | SV 06
Magnetic Welding Angles



MST | LM | MLDT | MLA | Mini Multi 07
Magnet Welding Fixtures



V-PAD | MAG-TAB | MIG Torch | MCB 08
Small Magnetic Welding Devices
Holding Magnet

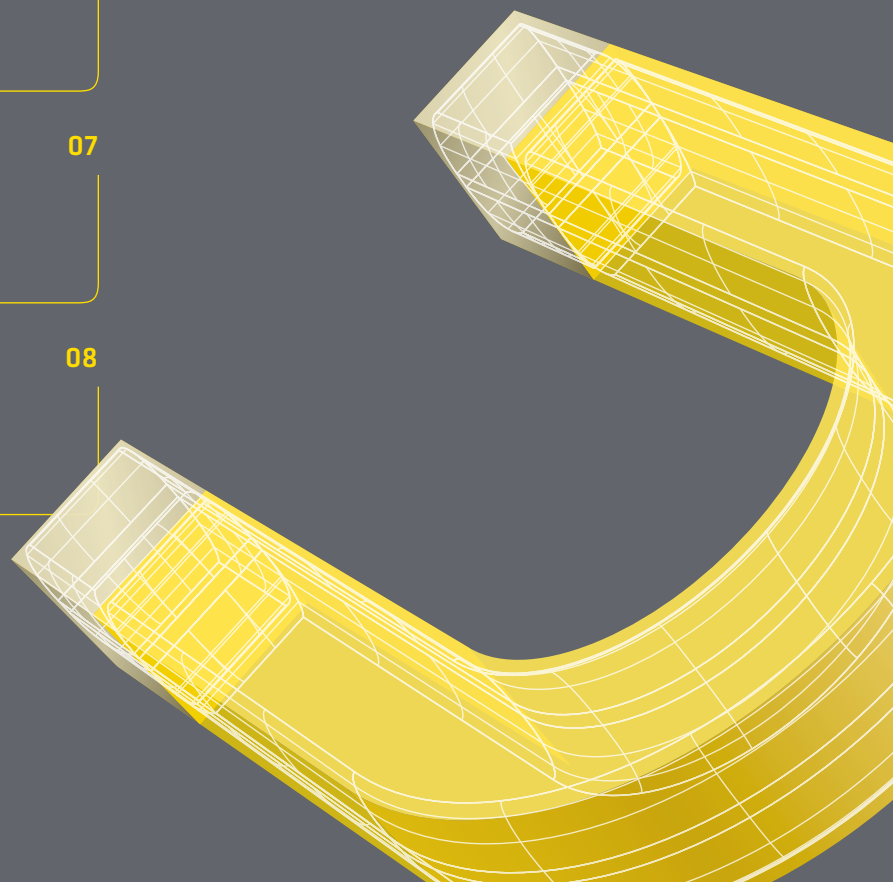

Separating | Holding | Lifting | Clamping

	<p>Magnetic Sheet Separators Magnetic Floaters</p>	10		<p>Magnetic Prisms V-Shape Magnetic Prisms</p>	16
	<p>HSM HSM-eco Manual Sorting Magnets Magnetic Sweeper</p>	11		<p>MSB Permanent Clamping Magnets</p>	17
	<p>Micromag Magnetic Filters</p>	12		<p>SPM Switchable Clamping Magnets</p>	18
	<p>HL 60-CE HL 60-CE-LH Handheld Magnetic Lifter</p>	13		<p>Laminated Support Blocks for Magnetic Chucks Laminated Support Blocks</p>	19
	<p>Pick and Place Permanent-magnetic Gripper Manual Permanentmagnet Lifter Magnetic Hand Tools</p>	14		<p>MA 01 MA 02 MA 03 MA 04 MA 05 MA 06 MA 07 Permanentmagnetic Precision Stop-pers</p>	20
	<p>Electric Adhesive Magnets for automation</p>	15			



Demagnetizing | Mini Magnets



Entmag-P
Demagnetizer plates

22-23



Entmag-T
Demagnetizer plates

24



Small Permanent Magnets

25-32



Further products in the overview

33

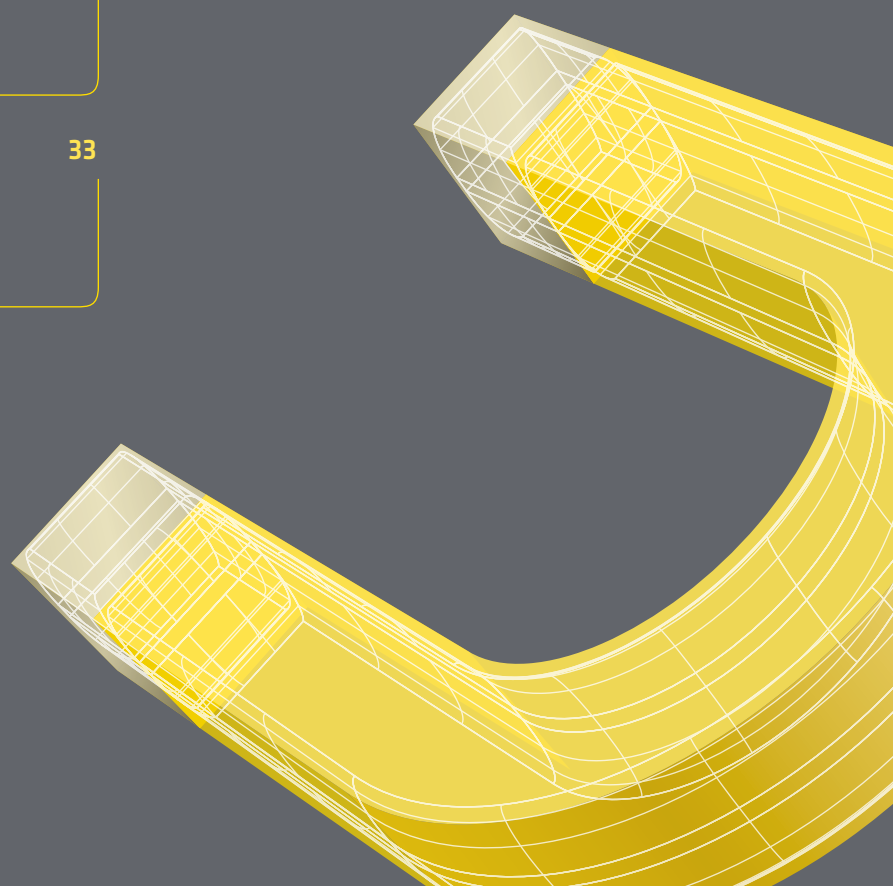

MSQ Magsquare | MagWheel | MagMount

Magnetic Workholding Tool

MSQ Magsquare is a versatile workholding and fixturing magnet. The magnetic grip is powerful on the 3 long sides. A simple 180° turn of the knob to switch ON / OFF. Pretapped holes on 4 sides for mounting.

MSQ is assembled in angle A90 and BA.

The Magwheel is a rollable magnetic holder. It offers a powerful connection for drive units on any steel surface that requires flat, vertical or inverted movement.

The Magmount can be used as a magnetic holder, for example for stands or fixtures.



MSQ Magsquare



MSQ Magsquare



MSQ Magsquare



MagWheel



MagMount

Features

- ✔ Magnets turns completely OFF and stays clean
- ✔ Usable for round and square work-pieces
- ✔ Magnetic power is powerful on 3 sides, only weak on the 2 short sides
- ✔ Pretapped holes on 4 sides for quick mounting
- ✔ Great for making own fixtures
- ✔ MagWheel applications: Positioning and guiding, sheet metal feeding, tube handling, assembly and manufacturing

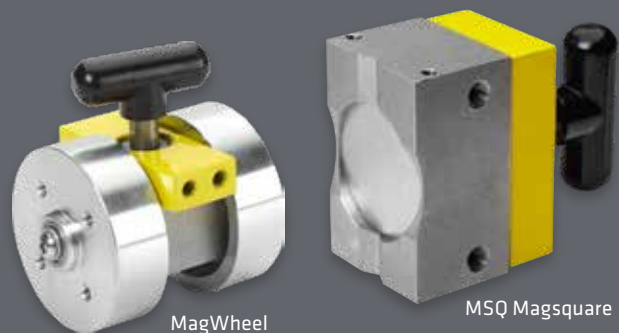

MagWheel

MSQ Magsquare

Technical data

	Dimensions [LxWxH]	Adhesive force	Weight	No.	Price
	[mm]	[kg]	[kg]		[€]
MSQ 165	48 x 31 x 65	68	0,3	61939	50,00
MSQ 400	64 x 42 x 90	181	0,9	60971	120,00
MSQ 600	75 x 52 x 106	272	1,4	60972	180,00
MSQ 1000	72 x 108 x 147	454	3,4	60973	400,00
MagWheel 150	68 x 52 x 72	29	1,0	64398	176,00
MagWheel 600	101 x 92 x 122	132	3,0	64399	378,00
MagMount 235	98 x 68 x 45	106	0,5	64649	120,00

Prices are subject to change

A 90 | BA | MS2

Magnetic Welding Angles

Your compact helper for welding or assembly works, for round and flat materials at an angle of 90° (A 90 or MS2), or at an angle of 0° - 360° (BA).

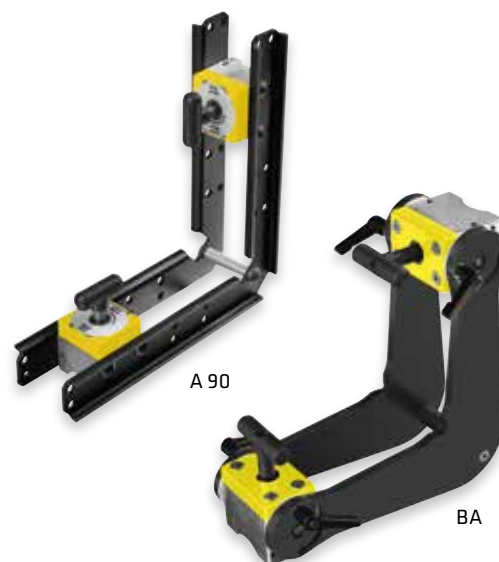

BA



A 90



MS2

Features

- ✔ MSQ Magnets can be completely switched off by just turning the switch lever by 180°
- ✔ Usable as well inside as outside angle
- ✔ Usable for round and square workpieces
- ✔ Powerful grip can be increased by additional MSQ (A 90)
- ✔ Sturdy steel construction of the angle
- ✔ Engraved scales for exact angle adjustment, 0 - 360° (BA)
- ✔ Fast and easy angle adjustment through fast tensioner (BA)



A 90

Technical data	Dimensions [L×W×H]	Adhesive force	Weight	No.	Price
	[mm]	[kg]	[kg]		[€]
A90-165	205 x 205 x 47	68	0,8	61945	160,00
A90-400	288 x 288 x 104	181	2,8	60340	300,00
A90-600	288 x 288 x 134	272	3,7	60341	350,00
A90-1000	287 x 474 x 145	454	4,6	60342	820,00
BA 150	196 x 196 x 80	68	1,3	60344	180,00
BA 400	257 x 257 x 109	181	3,0	60345	320,00
BA 600	257 x 257 x 169	272	4,4	60346	400,00
MS2-300	330 x 330 x 32	3 x 120	4,0	70505	350,00
MS2-450	550 x 550 x 45	3 x 300	4,0	70507	490,00

Prices are subject to change

MSA | MS | MAV | PA | SW | SV

Magnetic Welding Angles

Your universal magnetic "henchman" for welding and assembly works. All magnetic angles are switchable and suitable for flat and round material. Only SW and SV 100 are not switchable.

SV 100, MAV 120 and PA 200 are stepless adjustable angles.



MS



SW



SV 100



MAV 120



PA 200



MSA

Features

- ✔ Easy positioning, adjusting and fixing of workpieces
- ✔ No deflection or influence of welding arc
- ✔ The contact areas of MS, MAV 120 and PA 200 are separately switchable
- ✔ The angle of MAV120 and PA200 have a light and accurate angle adjustment by quick release and scale



Technical data	Dimensions	Angle	Switchable	Use also for round material	Adhesive force	Weight	No.	Price
	[L×W×H] [mm]							
MSA I	110 x 30 x 95	45°/90°	Yes	Yes	40	0,7	45338	54,00
MSA II	150 x 35 x 130	45°/90°	Yes	Yes	75	1,4	45339	68,00
MS 2-80	153 x 38 x 153	90°	Yes *	Yes	55	1,2	48192	130,00
MS 2-90	195 x 46 x 195	90°	Yes *	Yes	120	2,7	18736	170,00
MAV 120	197 x 50 x 197	30° - 275°	Yes *	Yes	50	2,4	162	190,00
PA 200	240 x 41 x 240	22° - 270°	Yes *	Yes	90	1,6	60343	180,00
SW 200	200 x 50 x 200	90°	No	No	40	2,5	46504	110,00
SW 300	300 x 50 x 300	90°	No	No	60	4,0	46503	130,00
SV 100	190 x 50 + 150 x 50	30° - 270°	No	No	100	2,0	22318	130,00

* Every thigh is separately switchable

Prices are subject to change

MST | LM | MLDT | MLA | Mini Multi

Small Magnetic Fixtures

Permanent magnets for your support.



MST 327

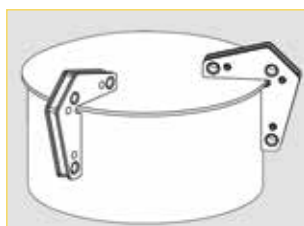
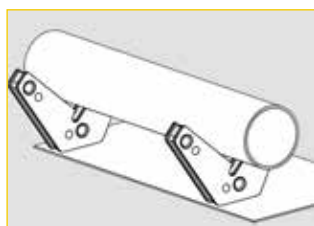

MST 327



MST 348



MLDT | MLA

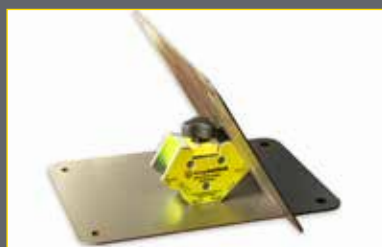

Mini Multi, switchable

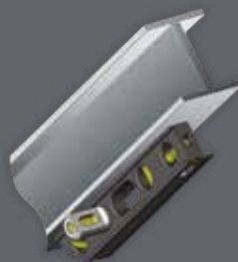

LM 3723



Technical data	Dimensions	Adhesive force	Angle	Weight	No.	Price
	[mm]	[kg]		[kg]		[€]
MST 327	95 x 83 x 16	14	60°, 90°	0,4	30324	30,00
MST 348	59 x 50 x 22	10	30°, 45°, 60°, 90°	0,3	55609	10,00
LM 3723	178 x 32 x 25	2	0°, 45°, 90°	0,3	62948	30,00
MLDT 350	125 x 85 x 14	15	90°	0,44	65716	25,00
	75 x 52 x 14	9	30° - 270°	0,13		
MLA 600	156 x 156 x 30	15	30° - 270°	0,87	65717	20,00
Mini Multi	72 x 32 x 65	40	45°, 135°, 60°	0,2	65268	35,00

Prices are subject to change

V-PAD | MAG-TAB | MIG Torch | MCB

Small Magnetic Welding Devices, Holding Magnet

For holding and positioning lightweight magnetic parts.

V-PAD



MAG-TAB

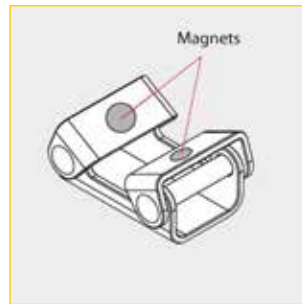
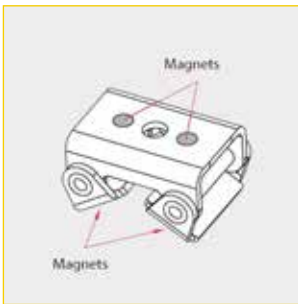

Holding Magnet MCB 82 - rubber coated it preserves the surface



MIG Torch - Holder with magnetic base for burner and plier

Technical data

Technical data	Dimension [mm]	Adhesive force [kg]	Weight [kg]	No.	Price [€]
V-PAD	70 x 35 + 55 x 20	8	0,4	55019	24,00
MAG-TAB MFT10	60 x 96 x 32	8	0,2	53093	10,00
MAG-TAB MNT15	100 x 130 x 38	16	0,2	67468	15,00
MIG Torch	-	-	0,5	70565	60,00
MCB 82	Ø 85 x 140	45	0,2	67467	60,00

Prices are subject to change

Ground magnets

Magnetic Ground Clamps

Magnetic Ground Clamps are extremely useful welding tools for quick and flexible earthing on plate or pipe. A switch turn activates the magnetic grip. It stays clean by turning OFF and wiping away debris.



800 A



300 A



600 A

Features

- ⌚ Extremely fast connection of the welding mass
- ⌚ Attachment to flat or rounded surfaces, like tubes
- ⌚ Safe connection of the welding ground with one switch turn
- ⌚ Switchable, therefore no chips sticks
- ⌚ Stable attachment of the welding mass
- ⌚ Only short cable length necessary
- ⌚ No deformation of the surface



800 A - 300 A

Technical data	Dimensions [HxW]	Hold surface [Ø]	Adhesive force	Weight	No.	Price
	[mm]	[mm]	[kg]	[kg]		[€]
300 A	58 x 74	40	40	0,4	62088	52,00
600 A	66 x 106	69	89	0,8	61985	120,00
800 A	74 x 126	89	136	1,6	64698	220,00

Prices are subject to change

Magnetic sheet separators

Magnetic Floaters

Switchable and non-switchable magnetic floaters separate piled sheets with thickness up to 6 mm. The upper sheets of the pile repel each other by magnetic power. Hence a single sheet can easily be picked.



Item no. 65117



Item no. 70345

Applications

- Easy separation of stacked sheets of any height stack is tackled easily
- Ideal for extracting ferrous impurities from bulk freight
- Item 65117 is a free floating and switchable design

Features

- Deep magnetic penetration
- Enormous air gap bridging
-> picking small parts over large air gap

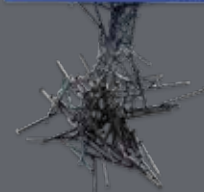

Typ 92. and PSC...

Technical data

	Dimensions [mm]	Number of threads	Item no.	Price
				[€]
92.07.073	75 x 73 x 28	2	122	38,00
92.10.103	104 x 103 x 28	2	123	70,00
92.13.105	143 x 104 x 49	2	124	110,00
92.26.105	277 x 104 x 49	2	126	195,00
92.30.105	310 x 104 x 49	2	127	218,00
92.35.105	344 x 104 x 49	2	128	239,00
92.40.105	411 x 104 x 49	3	129	280,00
92.45.105	444 x 104 x 49	3	12692	290,00
92.50.105	511 x 104 x 49	3	130	350,00
PSC 210 Nd	210 x 155 x 50	2	12689	132,00
PSC 220	220 x 183 x 77	2	42568	177,00
PSC 270	270 x 183 x 77	2	42569	285,00
PSC 310 Nd	310 x 154 x 47	2	51403	150,00
PSC 320	320 x 183 x 77	2	42570	320,00
PSC 420	420 x 183 x 77	3	42577	400,00
Separating magnet, switchable	190 x 196 x 228		65117	995,00
Separating magnet with a switchable magnetic base	411 x 154		70345	890,00

Prices are subject to change

HSM | HSM-eco

Manual Sorting Magnets | Magnetic Sweeper

The manual sorting magnet is preferably used for separating bulk material and lifting small parts such as bolts, nuts, nails or chips.

The magnetic sweeper attracts small magnetic parts like chips, also at difficult access. By pulling out the handle the chips fall down.



HSM-eco



HSM



Magnetic sweeper

Applications

- For holding small parts

Features

- Switchable ON/OFF
- Light design, compact and sturdy



Technical data	Supporting surface	Overall height	Weight	Item no.	Preis
	[mm]	[mm]	[kg]		[€]
HSM	188x105	130	1,7	64760	220,00
HSM-eco	155x135	205	2,6	21899	80,00
Magnetic Sweeper	Ø 25	L=380	0,5	42295	75,00

Prices are subject to change

Micromag

Magnetic Filters

The magnetic filter Micromag provides enormous filtration capacity for liquids and coolants.

Magnetic particles down to 0.2 μm are filtered out by the permanent magnetic core. Sporadically appearing non-magnetic particles are filtered out by means of the coagulation as well.

The filter can be easily incorporated in the coolant circuit by pipe threads.

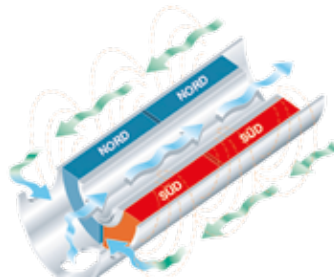

Applications

- ☑ Grinding, honing and lapping machines
- ☑ CNC-machines
- ☑ Fine-finishing machines
- ☑ Electric discharge machines
- ☑ Laser cutting machines
- ☑ Building and industrial heating systems
- ☑ Pump protection

Features

- ☑ Huge filtration capacity
- ☑ Easy and fast cleaning
- ☑ Temperature range: +5°C to +50°C
- ☑ Maximum operating pressure: 12 bar
Special designs from 0 - 80 bar are possible
- ☑ No extra costs - no additional disposal of filter media

Advantages

- ☑ Improved drilling, grinding and eroding results
- ☑ Longer lifetime of liquids
- ☑ Prolonged lifetime of tools
- ☑ Shorter maintenance and down times

Technical data

	Flow rate	\varnothing x length	Max. Dirt volume	Thread	Weight	Item no.	Price
	[l/min]	[mm]	[kg]	[inch "]	[kg]		[€]
Micromag MM5	70	80 x 125	1	1	2.5	46266	560,00
Micromag MM10	100	90 x 250	2	1	4.0	12514	940,00
Micromag MM20	150	90 x 500	4	1.5	8.0	45646	1650,00

Prices are subject to change

HL 60-CE | HL 60-CE-L

Handheld Magnetic Accu-Lifter

The permanent magnet handlifter HL 60-CE is especially designed for hot or sharp edged flamecut parts. It gets magnetized or demagnetized over push buttons on the handle. The HL 60-CE accu lasts for 1 000 switching cycles before recharging. The charger and an exchange accu are included.

The **HL 60-CE-L** is with long handle.



HL 60-CE



HL 60-CE



HL 60-CE



HL 60-CE-L, tiltable

Features

- ⚡ Fast handling of sharp-edged or hot metal parts
- ⚡ Electric clamping and loosening at the push of a button
- ⚡ Max. operation temperature 80°C
- ⚡ Keeps being absolutely clean after switching-off - no dirt, no particles or chips are sticking!
- ⚡ Up to 1 000 switches are possible with only one battery charge

Options

- ⚡ Service and repair according to the safety rules

Delivery contents

- ⚡ HL 60-CE | HL 60-CE-L
- ⚡ Charger 230V with 2 x accu 12V

Technical data

	Hold surface	Hight	Lifting force	Max. magnetpower at sheet thickness	Weight	No.	Price
	[mm]	[mm]	[kg]	[mm]	[kg]		[€]
HL 60-CE	56 x 42	209	30	> 5	1,1	60347	390,00
HL 60-CE-L, tiltable	56 x 42	830	30	> 5	2,5	69924	790,00

Prices are subject to change

Pick-And-Place Permanentmagnetic Gripper & Manual Permanentmagnet Lifter

Magnetic Hand Tools

These magnets enable securely picking-up inserting and removing curved workpieces for press or punch operations.

The hands remain outside the hazard zone - accidents are avoided. The manual magnet lifter ELM 100-H is switchable and for sheets thicker than 4mm.



HM1



PM1



Helios



HCM2



ELM 100-H

Applications

- For safe lifting and transporting of sheet-metal, flame-cut parts as well as sharp-edged and greasy workpieces

Features

Generals

- Maximum safety due to permanent magnets
- Heat-resistant up to 80°C
- Easy loosening by mechanical ejector or leverage ELM

ELM 100-H

- Picking-up of checker plates is possible

Technical data	Adhesive area / length	Lifting force	Towing force	Sheet-metal thickness	Weight	Item no.	Price
	[mm]	[kg]	[kg]	[mm]	[kg]		[€]
Helios 335	19 / 235	2	-	> 0.3	0.3	335	28,00
Helios 336	25 / 235	3	-	> 0.3	0.4	336	29,00
PM 1	65 x 300	5	-	> 0.3	0.4	342	35,00
HM 1	58 x 30	5	2	> 0.3	0.2	98	20,00
HCM 2	90 x 50	20	6	> 0.5	1.0	20057	42,00
ELM 100-H	84 x 60	100	40	> 15/10	3.0	45019	280,00

Prices are subject to change

Electric Adhesive Magnets

for automation

These automation magnets are used in handling and transport equipments.

The automation magnets are available in 2 versions:

- Holding (H): only as long as electric energy is supplied the magnetic power is activated.
- Loosening (L): For this purpose permanent magnetic power is compensated by electromagnetic energy. The workpiece is constantly picked and drops only when energy is supplied.

Type A: With strand,
500 mm long



Type B: 2-pin clamp
terminal



Types C + D: Hirschmann
connector with rectifier (C)
without rectifier (D)

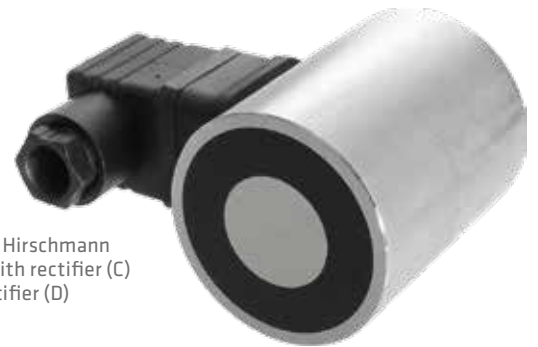

Applications

- ☑ For fast switching ferromagnetic workpieces
- ☑ In automation, special machine construction, material transporting and handling
- ☑ For fast switching cycles or constant magnetic grip with controlled release

Features

- ☑ With compact design for 12V or 24V or 240V DCAC
- ☑ Magnetic power independent on material thickness and surface finish (air gap)

Technical data

	Diameter	Height	Adhesive force	Voltage	Power consumption	Weight	Type
	[mm]	[mm]	[N]	[V]	[W]	[kg]	
Holding current							
M521-72 H	25	20	113	12	2.16	0.07	A
M521-72 H	25	20	113	24	2.16	0.07	A
M521-73 H	30	24	253	12	3.36	0.11	A
M521-73 H	30	24	253	24	3.36	0.11	A
M521-74 H	40	27	575	12	5.5	0.21	B
M521-74 H	40	27	575	24	5.5	0.21	B
M521-75 H	50	30	1097	12	5.7	0.36	B
M521-75 H	50	30	1097	24	5.7	0.36	B
M521-75 H	50	30	1097	240	8.56	0.41	C
M521-76 H	65	35	1677	12	8.2	0.71	B
M521-76 H	65	35	1677	24	8.2	0.71	B
M521-76 H	65	35	1677	240	10.7	0.74	C
Loosening current							
M521-77 L	35	48	285	24	5.5	0.35	D
M521-77 L	35	48	285	240	5.5	0.35	C
M521-78 L	50	63	471	24	8.5	0.87	D
M521-78 L	50	63	471	240	8.5	0.88	C

Prices are subject to change

Magnetic Prisms

V-Shape Magnetic Prisms

The permanent magnetic V-prisms are switchable and precise. The strong power is used for holding or clamping during measuring, grinding or other machining.



PMP

Applications

- ☑ For holding of cylindrical and complex workpieces
- ☑ Ideal for grinding and eroding processes as well as for measuring and marking works

Features

- ☑ Four magnetic clamping surfaces (top and bottom side as well as side surfaces)
- ☑ Switchable ON/OFF
- ☑ Can be rapidly and easily placed
- ☑ Also in pairs in polished version available

Technical data	Dimensions (L x W x H)	max ø	min ø	Tolerance	Weight	Item no.	Price/Pair
	[mm]	[mm]	[mm]	[µm]	[kg]		[€]
PMP75 (Pair)	75x75x56	40	5	5	1.79	62672	200,00
PMP100 (Pair)	100x95x70	65	5	5	3.96	62673	250,00

Prices are subject to change

MSB

Permanent Clamping Magnets

The permanent clamping magnets MSB are used for clamping shaped workpieces. A very strong version is also available for clamping tungsten carbide for example inserts or blanks.



MSB

Applications

- ☒ For clamping of shaped parts
- ☒ For grinding of carbide materials (type SmCo)

Features

- ☒ Permanently magnetic
- ☒ Not switchable
- ☒ Mechanically machineable

Technical data	Dimensions (L x W x H) [mm]	Magnetic adhesive areas	Item no.	Price [€]
MSB	100x100x50	1 x 100x100 mm	314	350,00
MSB	100x50x50	2 x 100x50 mm	315	210,00
MSB	100x25x25	2 x 100x25 mm	316	170,00
For grinding of tungsten carbide				
MSB...SmCo	100x100x50	2 x 100x50 mm	33477	1200,00
MSB...SmCo	100x50x50	1 x 100x50 mm	33478	700,00
MSB...SmCo	100x25x25	2 x 100x25 mm	33479	400,00

Prices are subject to change

SPM

Switchable Clamping Magnets

The clamping magnets SPM belong to useful accessories for clamping of small parts during grinding or EDM.



Applications

- ☑ Ideal for grinding and eroding machining, measuring and testing jobs
- ☑ Small magnetic workpieces from 0.5 mm thickness can be clamped

Features

- ☑ Magnetizable on all four longitudinal sides (SPM 2 L, SPM 2)
- ☑ Short payback period
- ☑ Universally applicable
- ☑ Absolutely water-proof
- ☑ Switchable on and off by pivoted lever
- ☑ All four sides are regrindable (SPM 2 L, SPM 2)

Technical data	Dimensions (L x W x H)	Adhesive force	Weight	Item no.	Price
	[mm]	[N/cm ²]	[kg]		[€]
SPM 2	175x64x64	80	3.2	309	630,00
SPM 2 L	195x64x64	80	3.8	28983	680,00
Non-corrosive					
SPM2 NiRo	175x64x64	50	3.2	28984	660,00
SPM 2 L NiRo	195x64x64	50	3.8	51915	700,00
SPM Eco 3 magnetic adhesive areas	150x70x85	50	5	63363	250,00

Prices are subject to change

Laminated Support Blocks For Magnetic Chucks

Laminated Support Blocks

The support blocks are mainly used in combination with magnetic bases. The support blocks can be machined for form fit of complex workpieces. The magnetic power is guided through the support block and clamps the workpiece on top. The lamination of the support block must correspond to the magnetic chuck pole pattern.

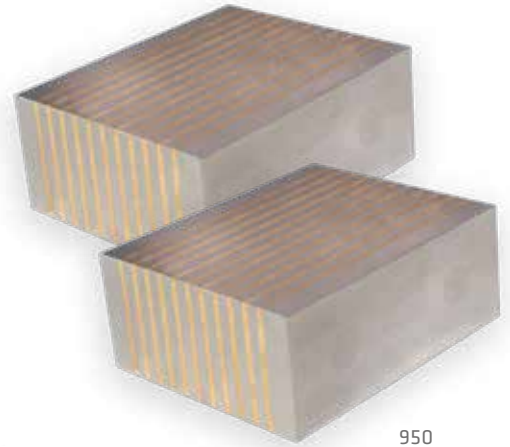

950



EHT-150



950 v Prisma

Applications

- The magnetic contact area between workpiece and magnetic chuck can be enlarged with non-machined and machined segmented support blocks

Features

- The blocks can be individually adjusted to the work requirements
- Blocks are also available in pairs
- Can be used both horizontally and vertically

Technical data	Dimensions (L x W x H) [mm]	Pole alignment	Item no.	Price [€]
950 (Pair)	60 x 75 x 30	longitudinal	62135	150,00
950 v Prisma (Pair)	50 x 100 x 40	longitudinal	62136	160,00
EHT-100	100 x 70 x 40	transverse	66332	350,00
EHT-150	150 x 75 x 25	transverse	64864	200,00
EHT-300	300 x 75 x 25	transverse	66333	400,00
Pole block	Different sizes	longitudinal + transverse		

Prices are subject to change

Other sizes on request

MA 01 | MA 02 | MA 03 | MA 04 | MA 05 | MA 06 | MA 07

Permanent Magnetic Precision Stoppers

These universal magnet stoppers reduce machining downtimes. They are suitable for all machine vices. No more time consuming installation of vice stoppers. Furthermore no thread holes are necessary.



MA 03



MA 01 | MA 02

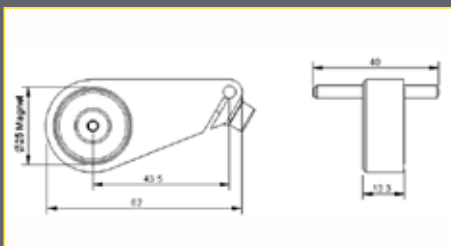

MA 04

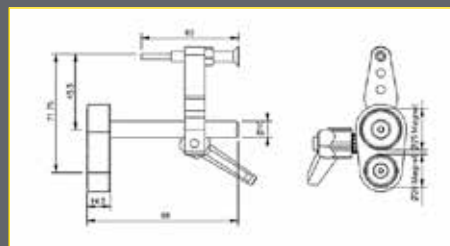

MA 03

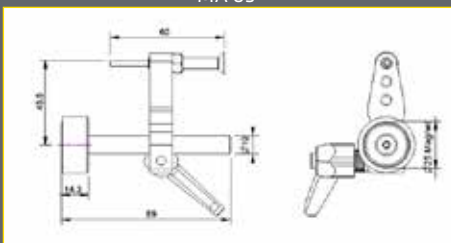

MA 05

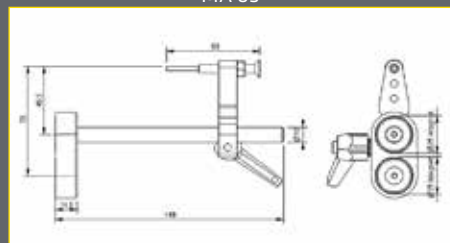



MA 06

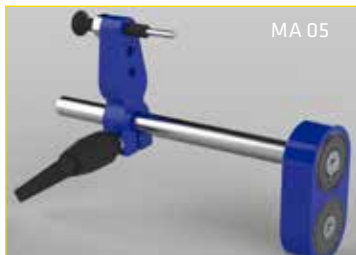

MA 05



MA 06



MA 07

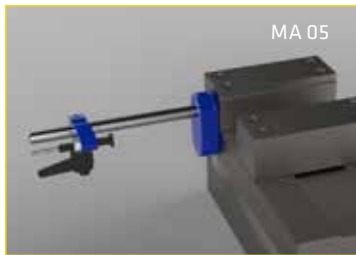

MA 05

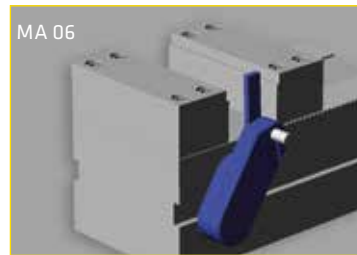

MA 06

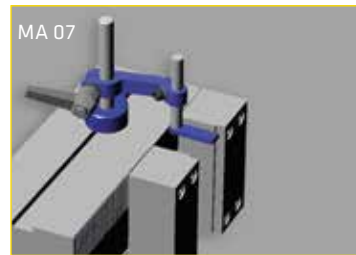

MA 07

Applications

- ☞ For milling processing centres
- ☞ Suitable for all kind of machine vices

Features

- ☞ High magnetic adhesive force
- ☞ High repetition accuracy
- ☞ Handy and space saving with a huge magnet holding power
- ☞ Quickly adjustable with clamping lever (MA 03)
- ☞ The max. suspension point is located above the holder - no danger of collision (MA 04)
- ☞ Strong magnetic force for big distances (MA 05)

Technical Data

	Adhesive force	Item no.	Preis
	[kg]		[€]
MA 01 right	19	42789	60,00
MA 02 left	19	70300	60,00
MA 03	19	70301	100,00
MA 04	27	70302	120,00
MA 05	38	70303	140,00
MA 06		70652	91,00
MA 07		70653	140,00

Prices are subject to change

Demagnetizing

Why demagnetizing?

All the ferrous and ferromagnetic materials may contain magnetic zones due to material polarisation caused by chip cutting, magnetic clamping and lifting or deforming process. Basically, magnetism is not harmful, but may interfere with further processing. Therefore magnetic zones sometimes must be eliminated. Hand, plate and tunnel demagnetizers are available.



Hand demagnetizer

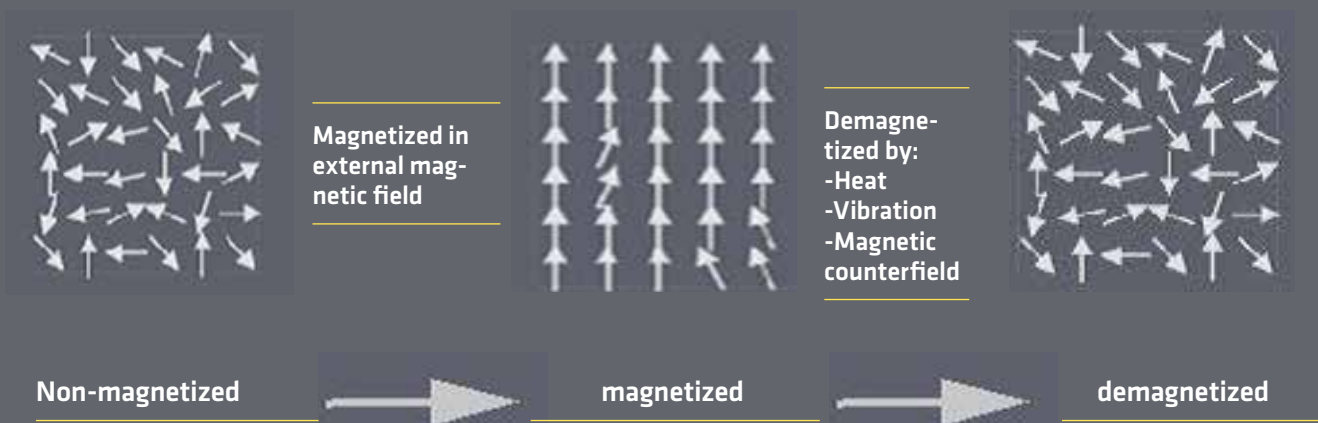

Plate demagnetizer



Tunnel demagnetizer

Demagnetizing



While demagnetizing, the magnetic field in the workpiece gets neutralised. The workpiece is magnetically neutral. The demagnetizing effect can be obtained by intense heating or a very strong alternating magnetic field. After demagnetization, the magnetic forces in the workpiece have disappeared. The magnetic field can be restored through remagnetization.

ENTMAG-P

Demagnetizer Plate

ENTMAG demagnetizing plates are a simple and cost-effective solution for the demagnetization of handsome magnetic workpieces. In a distance of 60 mm the workpiece must be moved slowly over the width of the demagnetizer plate (in dart direction). Integration in conveyor belts is also possible.

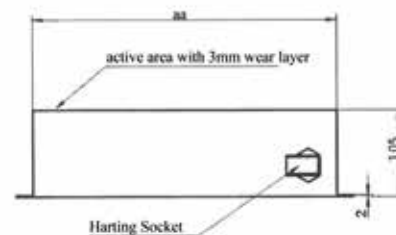

EDH 123



EDS 200

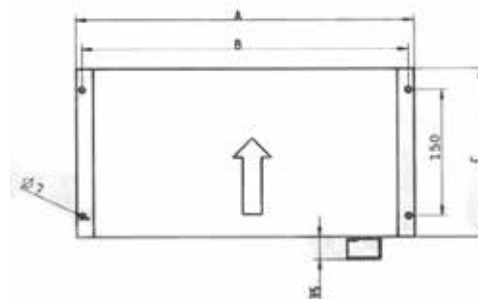

Applications

- ☑ Removing of annoying residual magnetism
- ☑ Demagnetizing is terminated after re-leaving the demagnetizer at a distance of approx. 300 mm

Features

- ☑ Robust, humidity-proof design (V2A-case)
- ☑ Suitable for workpieces made of soft and medium-hard material. High-grade hardened, intricate parts we recommend to check in advance
- ☑ All operating voltages at 50Hz or 60Hz are deliverable (lower frequency or pulse recurrence frequency for problematic cases)
- ☑ Connecting line, 2 m long, with plug connector
- ☑ Type 17 designed for incorporation in belt conveyors (flow-line production)
- ☑ Flow rate for demagnetizing <math><0.5\text{ m/s}</math>
- ☑ Practical hint: If a iron file slides from the turned workpiece, then the residual magnetism value is not more than 15 Gauss (1,5mT). To come down to 10 Gauss the help of demagnetizers is needed. For values below 10 Gauss special demagnetizing equipment is needed.

Technical data	Active area [mm]	Dimensions [mm]			Weight	Volt	ED	Item no.	Price
	NB x C	A	B	H	[kg]	[V]	[%]		[€]
P 17.1	225 x 180	260	244	180	20	400	100	64408	1675,00
P 17.2	355 x 190	396	380	190	34	400	80	66017	2350,00
P 17.3	425 x 190	466	450	190	41	400	80	65343	2700,00
EDH 123	123 x 83	123	83	83	1.8	230	50	42161	130,00
EDS 200	200 x 150	200	150	100	8.5	230	100	42176	220,00

Prices are subject to change

ENTMAG-T

Demagnetizing Plate

ENTMAG-T tunnel demagnetizers enable simple and fast demagnetization of ferromagnetic small and large-number parts. The workpiece is moved through the interior of the tunnel with help of conveyor belt, a slide or in free fall. Demagnetizing is terminated only after releasing the demagnetizer at a distance of approx. 300 mm. The workpieces are recommended to be demagnetized one by one. Clusters are to be avoided.

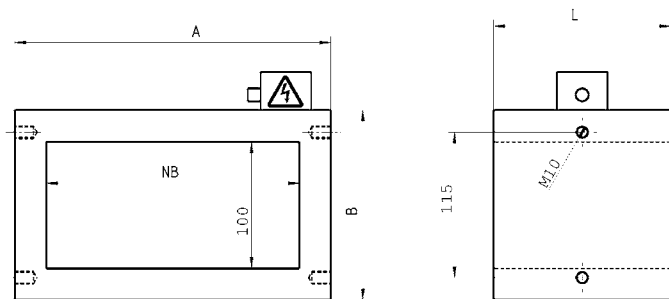

Applications

- ☑ Preferred for demagnetization of small and large-number parts
- ☑ The penetration depth of the workpiece is approx. 6 mm. The layer thickness at mass parts must not exceed 6 mm

Features

- ☑ Robust, humidity-proof design
- ☑ Type 163: Suitable for workpieces made of soft material. Type 164: Suitable for workpieces made of medium hard material. Special: High-grade hardened, intricate parts are recommended to be checked in advance
- ☑ All operating voltages at 50Hz or 60Hz are deliverable (lower frequency or pulse recurrence frequency for problematic cases)
- ☑ All working widths NB are deliverable from 150 to 800 mm
- ☑ Demagnetization can take place to less than 0.5 mT (5 Gauss). Test: Iron chips must not adhere on the workpiece

Technical data

	Dimensions [mm]					Weight [kg]	Item no.	Price [€]
	H	NB	L	A	B			
T 163	100	200	140	300	190	16	64153	1450,00
T 163	100	400	140	500	190	24		
T 163	150	400	190	500	240	34	64181	2030,00
T 164	100	200	140	320	210	29		
T 164	100	400	140	520	210	45	62592	2200,00
T 164	150	400	190	520	260	59	65157	2750,00

Prices are subject to change

Small Cylindric Permanent Magnets

Cylindric Gripper Magnets AlNiCo

Cylindric gripper magnets made of heat resistant AlNiCo.

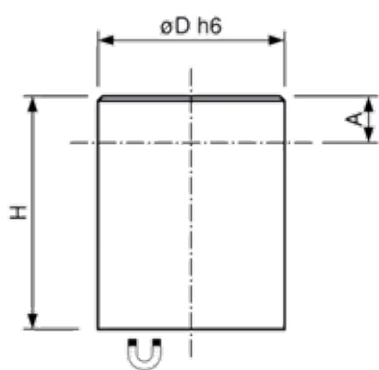

Applications

- ⚡ 001 AlNiCo:
 Material: AlNiCo
 fit tolerance h6,
 max. admissible temperature 450° C
- ⚡ 100 AlNiCo:
 Material: AlNiCo
 without fit tolerance,
 max. admissible temperature 450° C

Technical data

	Dimensions [mm]			Adhesive force [N]	Weight [g]	Item no.	Price [€]
	D	H	A				
Type 001 AlNiCo	6	10	2	2	2	208	2,30
	8	12	3	4	4	209	2,51
h6	10	16	6	8.5	9	210	2,66
	13	18	6	12	17	211	3,04
	16	20	6	20	29	212	4,17
	20	25	5	40	57	213	6,80
	25	30	7	60	110	214	9,41
	32	35	4	160	200	215	17,08
	40	45	5	240	420	216	30,00
	50	50	-	400	720	217	51,00
Type 100 AlNiCo	6	20	12	2	4.5	218	1,53
	8	20	11	4	7.5	219	1,74
without fit	10	20	10	8.5	12	220	2,50
tolerance	13	20	8	12	19	221	2,30
	16	20	6	20	30	222	2,97
	20	25	5	40	57	223	3,10
	25	35	13	60	125	224	8,00
	32	40	9	160	220	225	14,16
	40	50	10	240	440	226	26,00
	50	60	10	400	813	227	42,18

Prices are subject to change

Small Permanent Magnets

Cylindric Gripper Magnets Nd and CoSa

Made of CoSa or Nd high energy magnetic material.

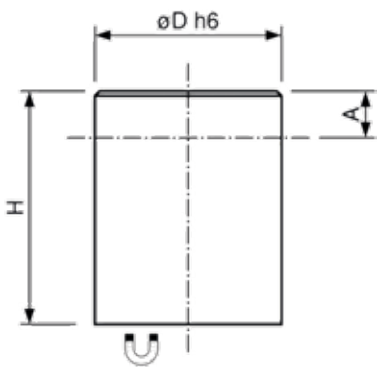

600 Co

600 Nd

Applications

- ⚡ 600 Co:
 - Material Cobalt-Samarium;
 - fit tolerance h6;
 - max. admissible temperature 200°C;
 - brass case
- ⚡ 600 Nd:
 - Material Neodymium;
 - fit tolerance h6;
 - max. admissible temperature 80°C;
 - brass case

Technical data

	Dimensions [mm]			Adhesive force [N]	Weight [g]	Item no.	Price [€]
	D	H	A				
Type 600 Co	6	20	10	8	4,5	265	3,12
h6	8	20	10	22	8	266	3,37
	10	20	8	40	12	267	5,11
	13	20	6	60	20	268	6,95
	16	20	2	125	30	269	8,16
	20	25	5	250	60	270	10,70
	25	35	7	400	135	2582	20,14
	32	40	4.5	600	250	272	39,52
Type 600 Nd	6	20	10	10	4,5	26232	2,58
h6	8	20	10	25	8	26233	2,99
	10	20	8	45	12	26234	4,04
	13	20	6	70	20	26235	4,88
	16	20	2	150	30	26236	5,11
	20	25	5	280	59	26237	7,82
	25	35	7	450	132	26238	14,96
	32	40	4.5	700	246	26239	25,67

Prices are subject to change

Small Permanent Magnets

Flat Gripper Magnets Fe - Co - Nd

Flat gripper magnets with galvanized case, with threaded bush.

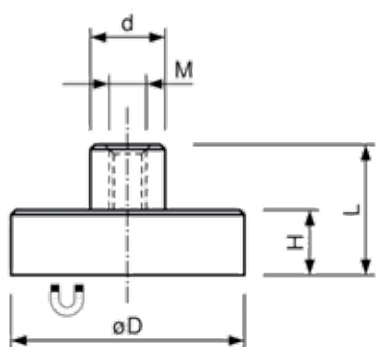

500 Fe



500 Co



500 Nd

Applications

- ☑ 500 Fe:
Material Ferrit;
max. admissible temperature 200°C
- ☑ 500 Co:
Material cobalt-samarium;
max. admissible temperature 200°C
- ☑ 500 Nd:
Material Neodymium;
max. admissible temperature 80°C;

Technical data

	Dimensions [mm]				Thread	Adhesive force [N]	Weight [g]	Item no.	Price [€]	
	D	H	L	d						
500 Fe	10	4.5	11.5	6	M3	4	3	249	0,89	
	13	4.5	11.5	6	M3	10	4	250	0,97	
	16	4.5	11.5	6	M3	18	6	251	1,18	
	20	6.0	13.0	6	M3	30	11	252	1,38	
	25	7.0	15.0	8	M4	40	20	253	1,53	
	32	7.0	15.0	8	M4	80	32	254	1,61	
500 Co	40	8.0	18.0	10	M5	125	60	255	2,20	
	50	10.0	22.0	12	M6	220	110	256	2,63	
	63	14.0	30.0	15	M8	350	240	257	4,65	
	80	18.0	34.0	20	M10	600	500	258	7,87	
	100	22.0	43.0	22	M12	900	940	259	17,90	
	125	26.0	50.0	25	M14	1300	1700	260	52,15	
	500 Nd	6	4.5	11.5	6	M3	5	2	26199	2,54
		8	4.5	11.5	6	M3	11	3	26200	2,66
		10	4.5	11.5	6	M3	20	4	26201	2,89
		13	4.5	11.5	6	M3	40	6	26202	4,60
16		4.5	11.5	6	M4	60	7	26203	5,88	
20		6.0	13.0	8	M4	90	16	26204	7,11	
25		7.0	14.0	8	M4	150	28	26205	11,35	
32		7.0	15.5	10	M5	220	47	26206	17,33	
500 Nd	6	4.5	11.5	6	M3	5	2	26183	1,59	
	8	4.5	11.5	6	M3	13	3	26184	1,82	
	10	4.5	11.5	6	M3	25	4	26185	2,02	
	13	4.5	11.5	6	M3	60	5	26186	2,16	
	16	4.5	11.5	6	M4	95	7	26187	2,58	
	20	6.0	13.0	8	M4	140	16	26188	4,04	
	25	7.0	14.0	8	M4	200	27	26189	6,34	
	32	7.0	15.5	10	M5	350	45	26190	8,79	

Prices are subject to change

Small Permanent Magnets

Flat Gripper Magnets without threaded bush

Flat gripper magnets with galvanized case.

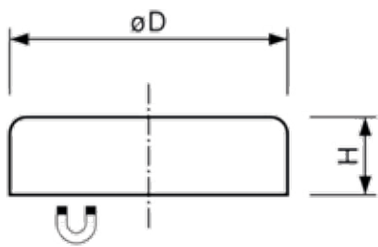

Applications

- ☑ 500 Fe:
Material Ferrit;
max. admissible temperature 200°C
- ☑ 500 Co:
Material Cobalt-Samarium;
max. admissible temperature 200°C
- ☑ 500 Nd:
Material Neodymium;
max. admissible temperature 80°C

Technical data

	Dimensions [mm]		Adhesive force	Weight	Item no.	Price [€]
	D	H	[N]	[g]		
500 Fe	10	4.5	4	2	238	0,74
	13	4.5	10	3	239	0,82
	16	4.5	18	5	240	0,97
	20	6.0	30	10	241	1,23
	25	7.0	40	18	242	1,38
	32	7.0	80	29	243	1,43
	40	8.0	125	55	244	1,94
	50	10.0	220	102	245	2,40
	63	14.0	350	226	246	3,89
	80	18.0	600	468	247	7,52
500 Co	100	22.0	900	915	9601	13,55
	125	26.0	1300	1680	35	48,57
	6	4.5	5	1	26191	1,99
	8	4.5	11	2	26192	2,22
	10	4.5	20	3	26193	2,66
	13	4.5	40	4	26194	4,17
	16	4.5	60	7	26195	5,87
	20	6.0	90	14	26196	6,44
500 Nd	25	7.0	150	26	26197	10,99
	32	7.0	220	42	26198	15,90
	6	4.5	5	1	26169	1,41
	8	4.5	13	2	26170	1,61
	10	4.5	25	2.5	26171	1,84
	13	4.5	60	4	26172	1,99
	16	4.5	95	6	26179	2,30
	20	6.0	140	14	26180	3,40
25	7.0	200	25	26181	5,09	
32	7.0	350	41	26182	7,72	

Prices are subject to change

Small Permanent Magnets

Flat Gripper Magnets with internal thread / with countersink / with cylinder bore

Flat adhesive magnets made of magnetic steel, with a galvanized case

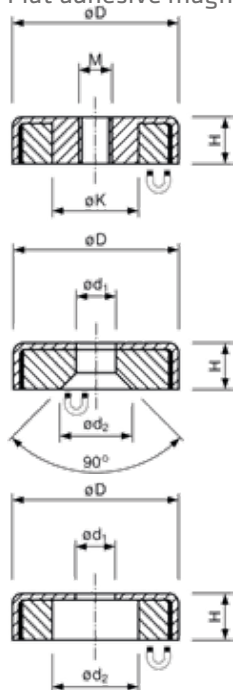

200 Fe

700 Fe with countersink

700 Fe with cylinder bore

Applications

- ⚡ 200 Fe:
 Material Ferrit;
 max. admissible temperature 200°C
- ⚡ 700 Fe:
 Material Ferrit;
 max. admissible temperature 200°C

Type 200 Fe

	Dimensions [mm]			Thread	Adhesive force [N]	Weight [g]	Item no.	Price [€]
	D	H	K					
with internal thread	50	10	12.0	M 6	170	170	33888	3,98
	63	14	13.0	M 8	290	206	33887	7,84
	80	18	14.5	M 8	550	472	33886	9,66
	80	18	14.5	M 10	550	466	33788	9,66

Type 700 Fe

	Dimensions [mm]				Adhesive force [N]	Weight [g]	Item no.	Price [€]
	D	H	d1	d2				
with countersink	16	4.5	3.5	6.5	14	4	22504	1,12
	20	6.0	4.2	9.4	27	9	22505	1,38
	25	7.0	5.5	11.5	36	16	22506	1,53
	32	7.0	5.5	11.5	72	27	11799	1,61
	40	8.0	5.5	11.5	90	53	15091	2,02
with cylinder bore	50	10.0	8.5	22	180	90	22494	2,51
	63	14.0	6.5	24	290	195	22490	4,40
	80	18.0	6.5	11.5	540	478	22493	7,93

Prices are subject to change

Small Permanent Magnets

Flat Gripper Magnets with hook / with threaded bolts

Flat adhesive magnets made of magnetic steel,
lacquered / galvanized case

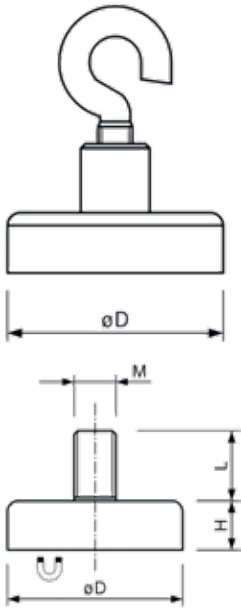

DMAG

200 Fe

Applications

- ⚡ DMAG:
Material Ferrit;
max. admissible temperature 200°C,
with hook
- ⚡ 200 Fe:
Material Ferrit;
max. admissible temperature 200°C,
with threaded bolt

Type DMAG

	Dimensions [mm]		Thread	Adhesive force [N]	Weight [g]	Item no.	Price [€]
	D	H					
with hook	25		M 4	40	23	41213	1,59
	32		M 4	80	34	41214	1,69
	40		M 4	125	59	34084	2,53
	50		M 4	220	107	41216	2,49

Type 200 Fe

	Dimensions [mm]			Thread	Adhesive force [N]	Weight [g]	Item no.	Price [€]
	D	H	L					
with threaded bolt	10	4.5	7	M 3	4	2	22498	1,20
	13	4.5	7	M 3	10	3	22499	0,97
	16	4.5	7	M 3	20	5	22500	1,14
	20	6.0	7	M 3	30	10	22501	1,46
	25	7.0	8	M 4	40	19	22502	1,59
	32	7.0	8	M 4	80	30	22503	1,94

Prices are subject to change

Small Permanent Magnets

Organisation Magnets

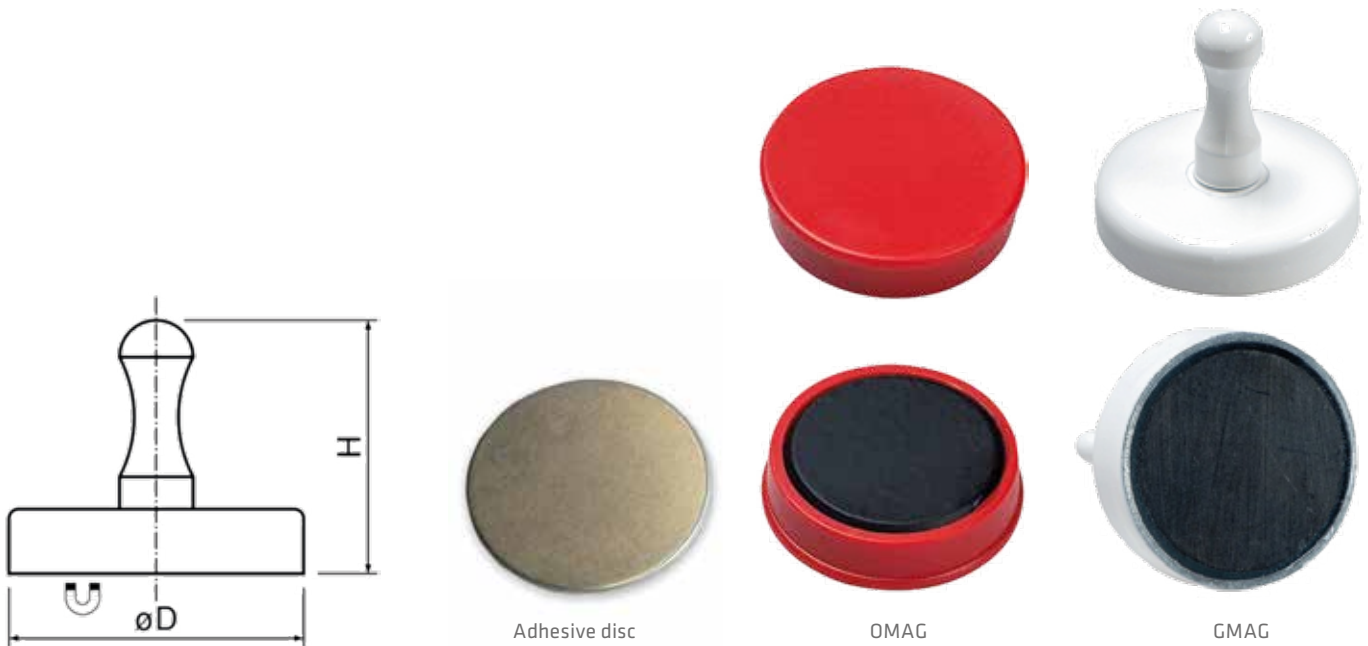

Applications

- ☞ OMAG:
Material Neodymium,
plastic-coated
- ☞ GMAG:
Material Ferrit,
white lacquered

Type OMAG	Dimensions [mm]		Adhesive force [N]	Adhesive force						Price [€]
	D	H		yellow	red	green	blue	black	white	
	25	8	14	71285	71286	71287	71288	71289	71290	1,10
	30	7,8	27	71292	71293	71294	71295	71296	71297	1,25
	35	8,5	35	71298	295	71299	71300	71301	71302	1,30

Type GMAG	Dimensions [mm]		Surface	Adhesive force [N]	Weight [g]	Item no.	Price [€]
	12	16.0	nickel-plated	55	7	36490	1,43
	25	22.0	white painted	40	25	26175	2,20
	32	22.0	white painted	80	35	26176	2,40
	36	29.5	white painted	100	45	26177	2,60
	40	29.5	white painted	125	62	26178	2,80

Accessories

Adhesive disc, one-sided self-adhesive

Dimensions [mm]		Item no.	Price [€]
D	H		
20	1	70410	0,40
30	1	37606	0,50
60	1,5	37607	0,80

Prices are subject to change

Small Permanent Magnets

Button, Pot, U-Magnets up to 450°C

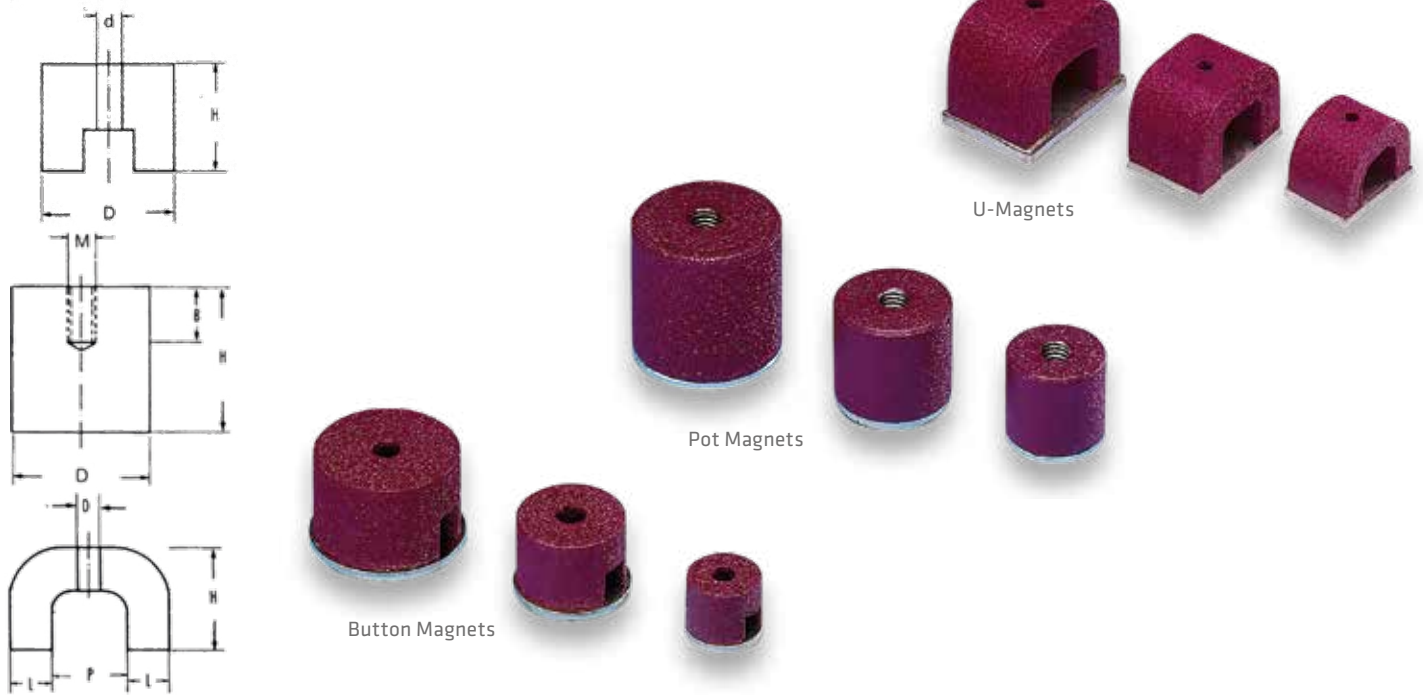

Applications

- ☑ Button magnets, through bore, divided adhesive area, Material AlNiCo; max. admissible temperature 450°C
- ☑ Pot magnets Material: AlNiCo with thread; max. admissible temperature 450°C
- ☑ U-magnets: Material AlNiCo; max. temperature 450°C

Technical data

	Dimensions [mm]		Bore / thread [mm]	Adhesive force [N]	Weight [g]	Item no.	Price [€]
	D	H	d/M				
Button magnets	13	10	4.2	7	7	180	2,10
	19	13	5.4	19	20	181	3,40
	25	16	5.4	29	56	182	5,70
Pot magnets	32	25	7	66	133	183	9,50
	19	8	3.5	30	18	184	3,30
	29	9	5	55	46	185	4,60
	38	10.5	5	95	97	186	8,40
	17	16	M 6	18	26	188	3,90
	21	19	M 6	28	50	189	4,70
	27	25	M 6	65	110	190	6,30
	35	30	M 6	120	215	191	8,50

Technical data

	Total	Dimensions [mm]				Adhesive force [N]	Weight [g]	Item no.	Price [€]
		L	P	B	H				
U-magnets	31	8	15	20	20	45	65	173	8,00
	40	10	20	25	25	90	150	174	9,00
	44	11	22	29	30	120	220	175	15,00
	57	11	35	35.5	35	230	380	176	36,00
	71	15	41	57	41	320	1600	177	55,00
	78	15	48	82	54.5	470	2000	178	90,00

Prices are subject to change

Further products in the overview



WANT TO KNOW MORE?

We are happy to advise you by telephone or with a personal appointment.

➤ T +49 (0) 71 71 92 505-0

➤ info@assfalg-metal.com



www.assfalg-metal.com

Assfalg GmbH

Buchstraße 149
73525 Schwäbisch Gmünd
Germany

Tel +49 (0) 71 71 92 505-0

Fax +49 (0) 71 71 92 505-50

assfalg