

# CATALOGUE

ALUMINIUM & PVC  
Cutting machines  
Windows & doors machines

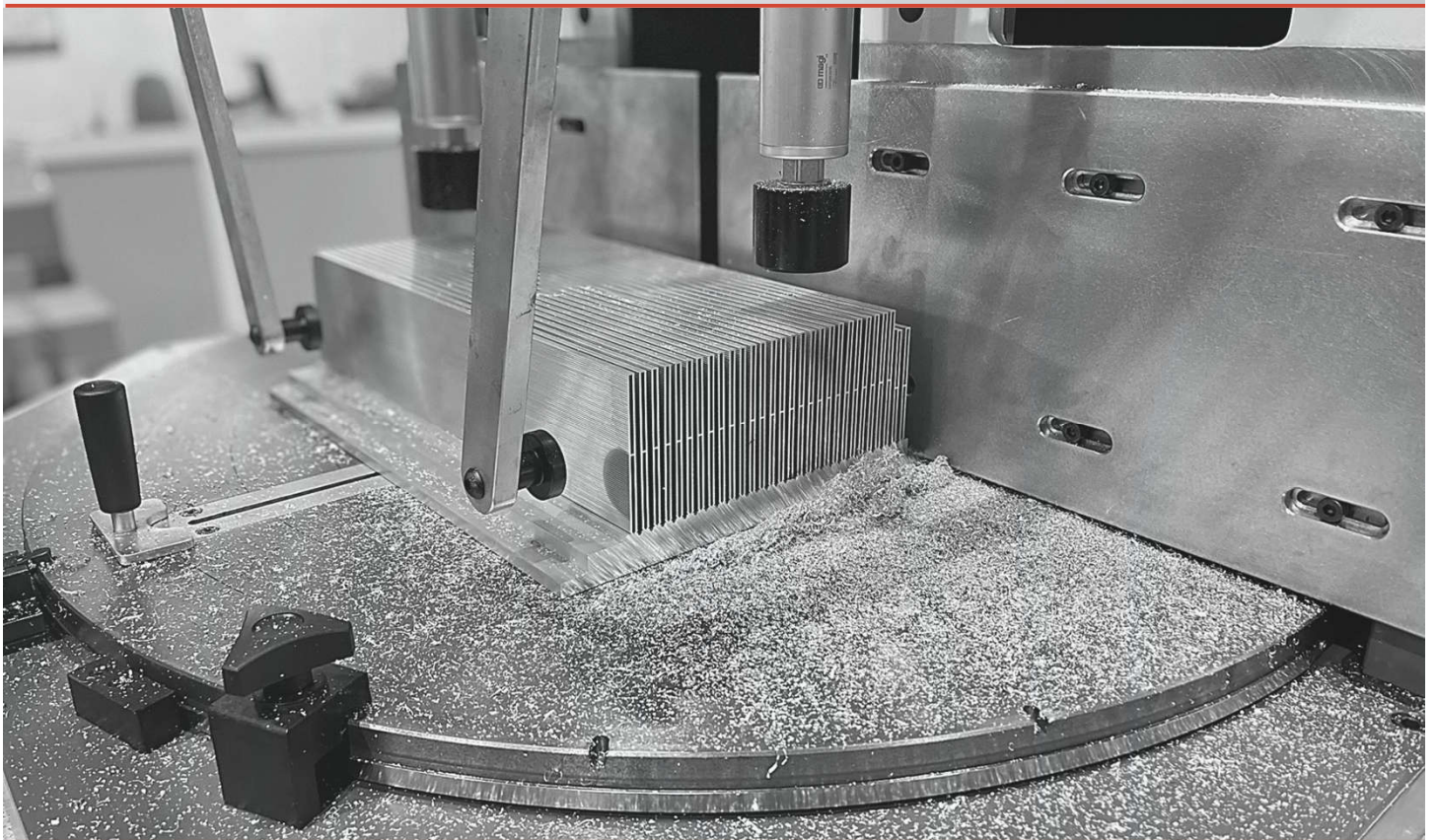

# 2023



[www.tronzadorasmg.com](http://www.tronzadorasmg.com)



# THE COMPANY

Proudly family company producing quality machines during  
50 years in Spain

When the company was founded in Barcelona in 1972, the main destination of our machines was the local market of Spain. Nowadays we export to more than fifty countries worldwide, striving to manufacture enduring machines and supporting our customers with quality and personal service

We take care of every detail to produce quality and enduring machines.

We proudly produce in Europe according to CE normatives and ISO 9001:2015 quality management.



# INDEX OF MACHINES BY CATEGORIES

1) ALUMINIUM MITER CUTTING	Pag. 4 - 8
2) ALUMINIUM AUTOMATIC FEEDING AND MITER CUTTING MACHINE	Pag. 9 - 10
3) ALUMINIUM SINGLE BLADE 90° CUTTING	Pag. 11
4) ALUMINIUM 90° AUTOMATIC CUTTING	Pag. 12 - 14
5) AUTOMATIC PROFILES LOADER FOR GAA MACHINES	Pag. 15
6) ALUMINIUM 90° AUTOMATIC CUTTING & DRILLING	Pag. 16 - 18
7) DOUBLE MITER CUTTING MACHINE	Pag. 19
8) MACHINING CENTER	Pag. 20 - 21
9) POSITIONING SYSTEMS / ROLLER CONVEYORS	Pag. 22
10) MOTORIZED POSITIONING SYSTEMS / FEEDERS	Pag. 23
11) COPY ROUTERS FOR ALUMINIUM / PVC	Pag. 24 - 25
12) END MILLING MACHINES FOR ALUMINIUM / PVC	Pag. 26 - 27
13) PRESSES FOR ALUMINIUM PROFILES	Pag. 28
14) ASSEMBLY TABLES	Pag. 29
15) PROFILES HANDLING SYSTEMS	Pag. 30
16) VACUUM CLEANERS	Pag. 31 - 32
17) CORNER CRIMPING MACHINE / PROFILES BENDING MACHINE	Pag. 33

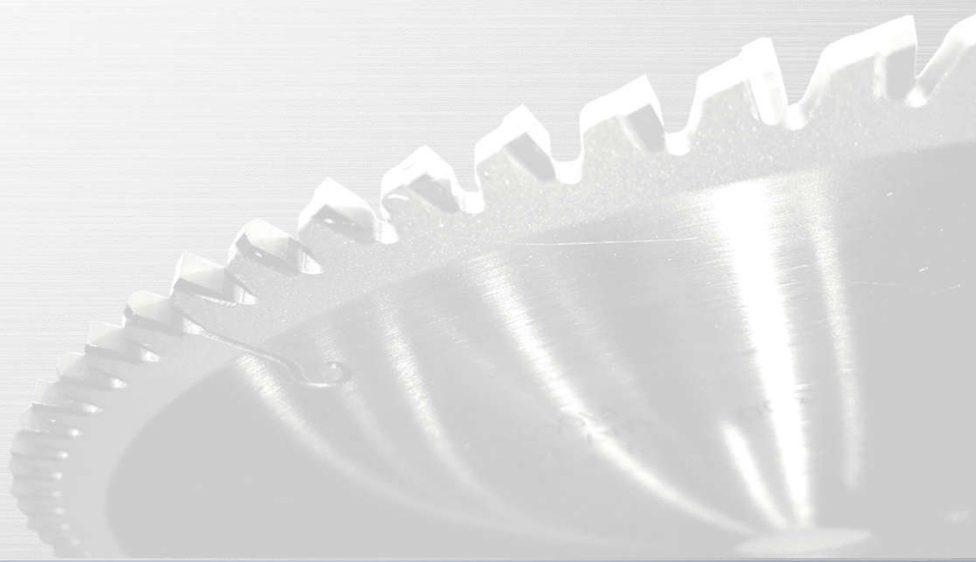

# ALUMINIUM MITER CUTTING

## TL-350-SA

## TL-350-M



TL-302-M » TL-350-M » Manual Clamping, Manual pumping lubrication and Manual raise of blade  
 TL-302-SA » TL-350-SA » Pneumatic Clamping, Pneumatic lubrication and Manual raise of blade

Movable backfence 50mm  
 Rotary Stand

	TL-302-M / SA
Blade Dimensions	300 Ø mm
Motor	2,0 HP
Motor speed	3000 rpm
Working height	950 mm
Cutting degrees	-22,5°/-45°/90°/45°/22,5°/-0°
Weight of the machine	60 kg

	TL-350-M / SA
Blade Dimensions	350 Ø mm
Motor	2,0 HP
Motor speed	3000 rpm
Working height	970 mm
Cutting degrees	-22,5°/-45°/90°/45°/22,5°/-0°
Weight of the machine	68 kg

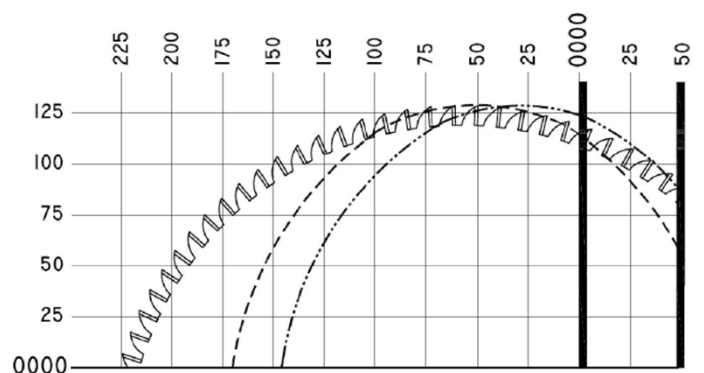
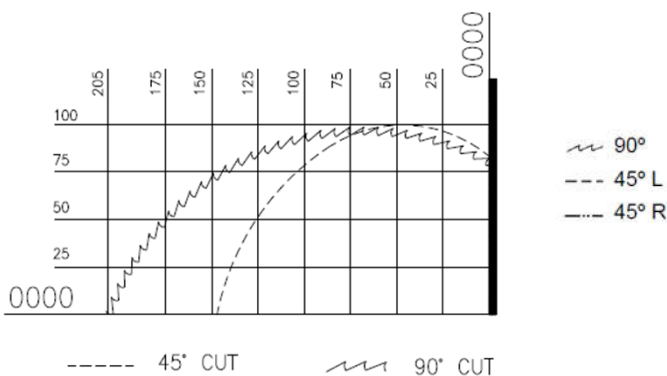

# ALUMINIUM MITER CUTTING

## TLG-352-M

## TLG-352-SA

## TLG-352-A



The TLG range of miter cutting Machine for Aluminium, PVC and light metals with Ø350 mm blade and angle positioning from 0° to 180° and movable backfence 130mm to reach bigger cutting capacities

TLG-352-M » Manual Clamping, Manual pumping lubrication and Manual raise of blade

TLG-352-SA » Pneumatic Clamping, Pneumatic lubrication and Manual raise of blade

TLG-352-A » Pneumatic Clamping, Pneumatic lubrication and Pneumatic raise of blade

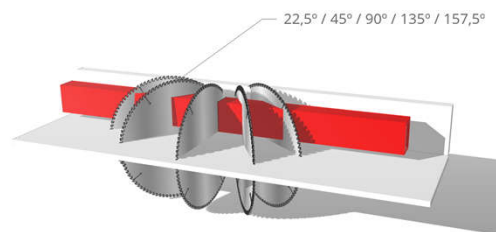

	TLG-352-M / SA / A
Blade Dimensions	350 Ø mm
Motor	2 HP (1,5 Kw)
Motor speed	3000 rpm
Working height	970 mm
Cutting degrees	0°/-22,5°/-45°/90°/135°/157,5°/180°
Weight	180 kg

*Options:*  
 Lubetools mist lubrication  
 Digital angles display  
 Laser line  
 Automatic hood opening  
 Led illumination

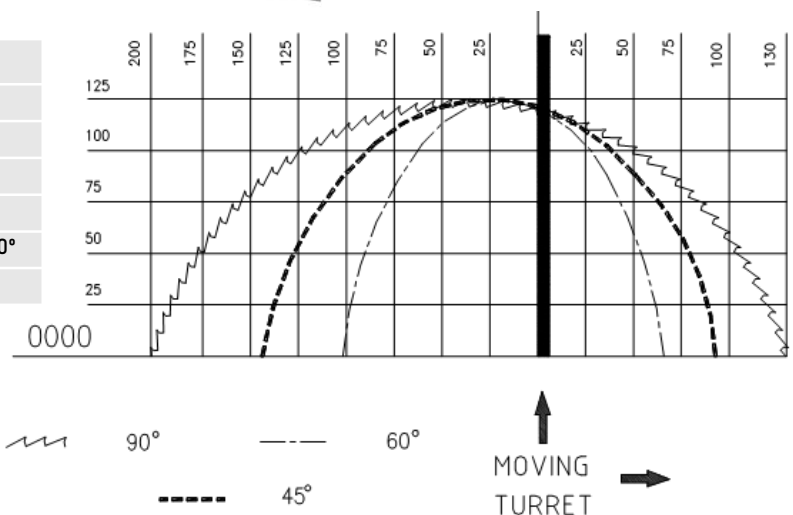

# ALUMINIUM MITER CUTTING

## TL-400-A



## FRONT-450



	TL-400-A
Blade Dimensions	400 Ø mm
Motor	3 HP
Motor speed	3000 rpm
Working height	970 mm

	FRONT-450
Blade Dimensions	450 Ø mm
Motor	3 HP
Motor speed	3000 rpm
Working height	970 mm

22,5° / 45° / 90° / 135° / 157,5°  
MANUAL

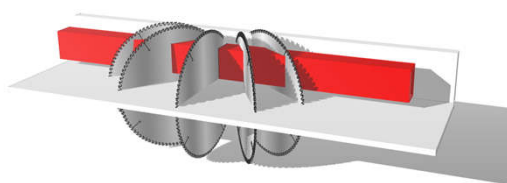

22,5° / 45° / 90° / 45° PNEUMATIC

-22,5° / -45° / 90° / 45°

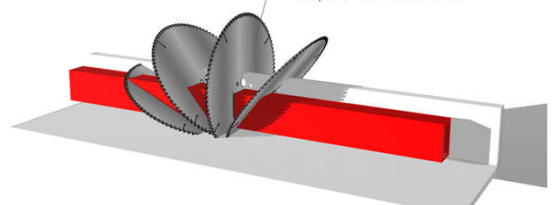

### CUTTING CAPACITY

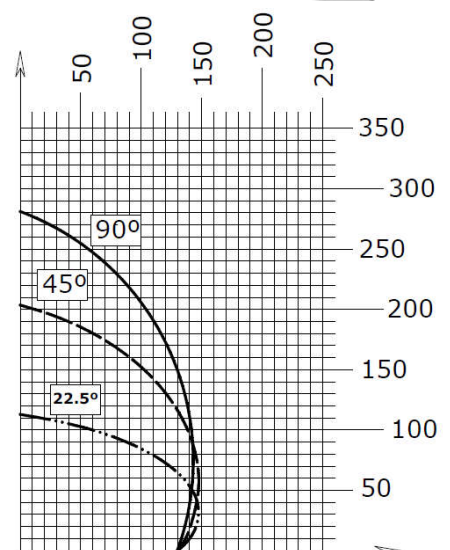
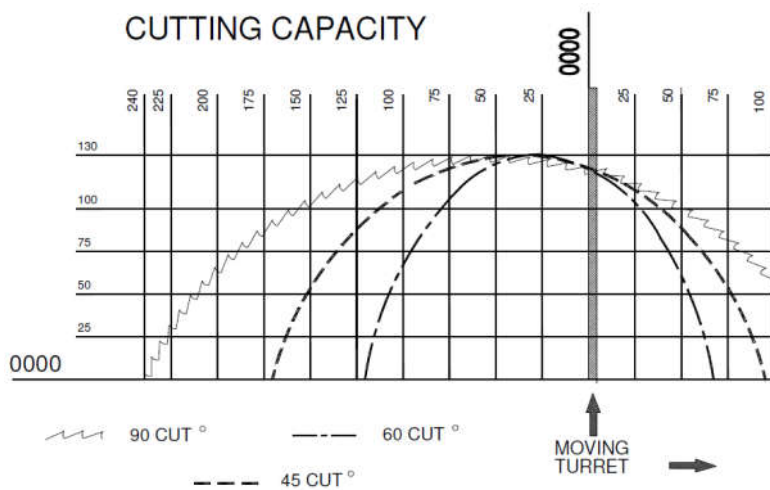

# ALUMINIUM MITER CUTTING

## TL-500-A



## TL-600-A



	TL-500-A
Blade Dimensions	500 Ø mm
Motor	4 HP (3,0 Kw)
Motor speed	3000 rpm

	TL-600-A
Blade Dimensions	600 Ø mm
Motor	4 HP (3 Kw)
Motor speed	3000 rpm

22,5° / 45° / 90° / 135° / 157,5°  
MANUAL

Options:  
Lubetools mist lubrication  
Digital angles display  
Laser line  
Automatic hood opening  
Led illumination

Options:  
Motor 4 Kw (5,3HP)  
Motor 5,5 Kw (7,5 HP)  
22,5° / 45° / 90° / 135° / 157,5°  
MANUAL

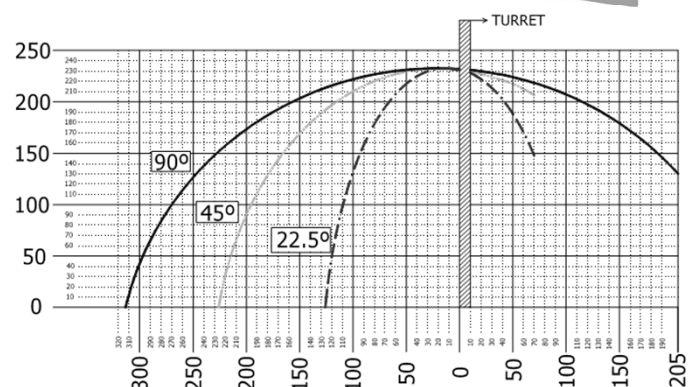
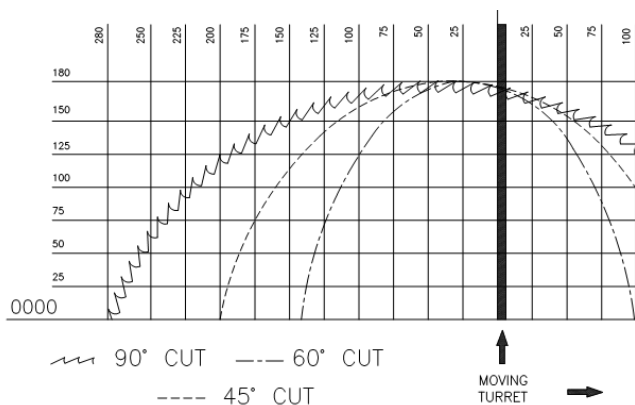
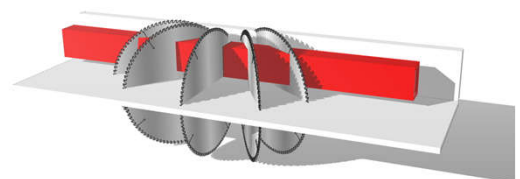
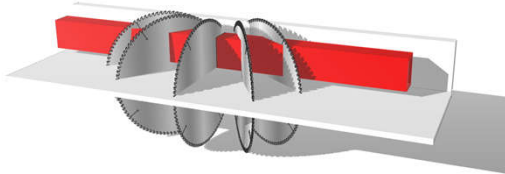

# ALUMINIUM MITER CUTTING

## TL-650-A



## TL-800-A



	TL-650-A
Blade Dimensions	650 Ø mm
Motor	7,5 HP (5,5 Kw)
Cutting speed	55 m/sec
Working height	970 mm
Cutting degrees	-22,5°/-45°/90°/45°/22,5°

	TL-800-A
Blade Dimensions	800 Ø mm
Motor	10 HP (7,5 Kw)
Cutting speed	30-70 m/sec
Working height	970 mm
Cutting degrees	-22,5°/-45°/90°/45°/22,5°

22,5° / 45° / 90° / 135° / 157,5°  
MANUAL

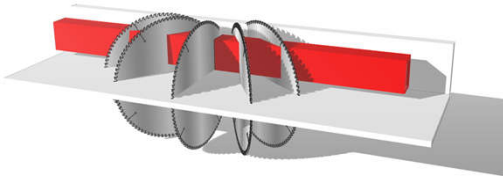

*Options:*  
Lubetools mist lubrication  
Digital angles display  
Laser line  
Automatic hood opening  
Led illumination

22,5° / 45° / 90° / 135° / 157,5°  
MANUAL

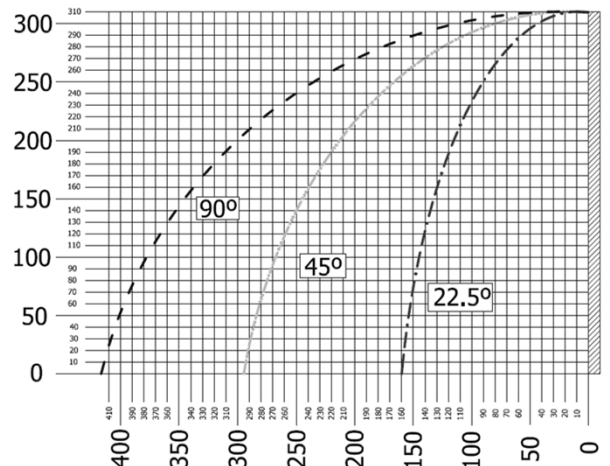
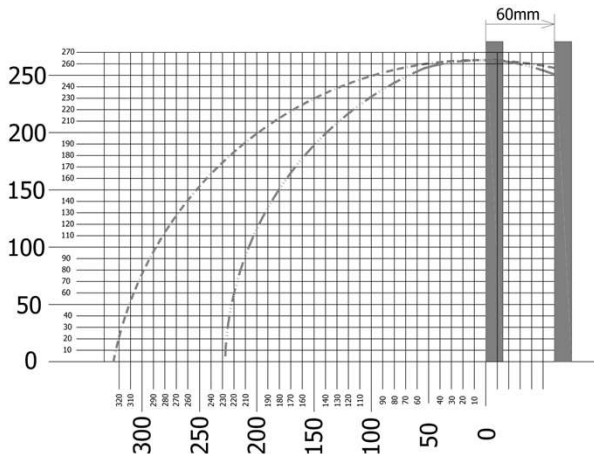
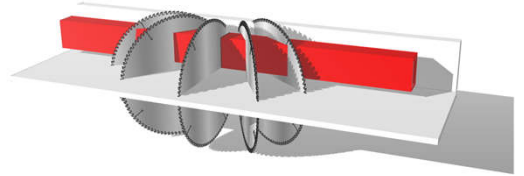



# FRONT-450 CNC AAG

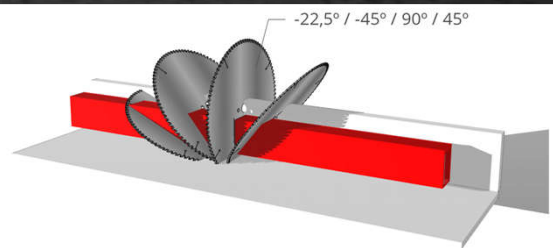
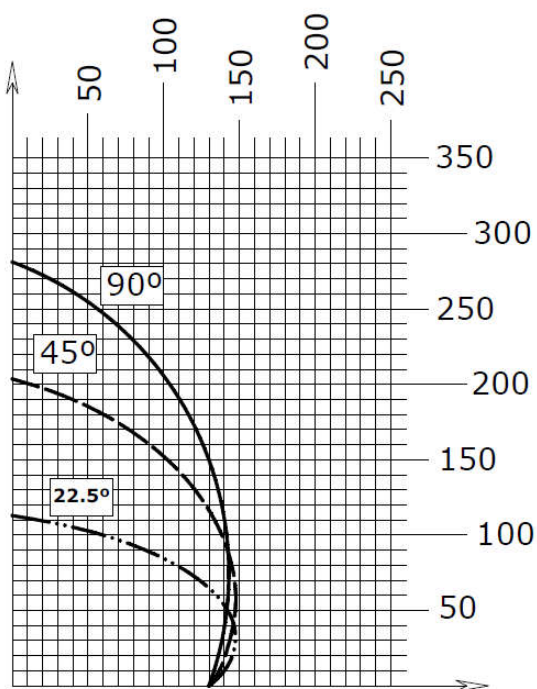

*The FRONT-450 AAG CNC is a fully automatic cutting Machine with feeding and automatic blade turning with oleopneumatic cylinders reaching angles from 22,5° to 135°*

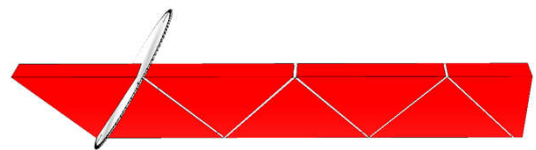

	FRONT-450 AAG CNC
Blade Dimensions	450 Ø mm
Motor	3 HP (2,2 Kw)
Motor speed	3000 rpm

# ALUMINIUM AUTOMATIC FEEDING AND MITER CUTTING MACHINE

## TL-600-AAG CNC



*45° to 135° automatic blade turning by Servo motor*

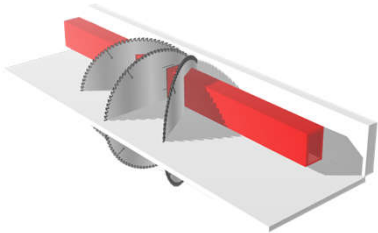

*Automatic turning of the blade by servo motor to intermediate angles*

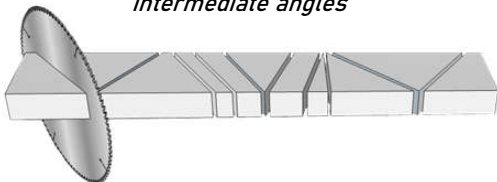

*The TL-600 AAG CNC is a fully automatic cutting Machine with feeding and automatic blade turning with servo motor reaching angles from 45° to 135°*

*The programmable controller working with a 5,6" color Touch screen panel, accepts 10 programs, and 30 cutting list lines in each program. It also accepts a library of 20 parts*

TL-600-AAG CNC	
Blade Dimensions	600 Ø mm
Motor	4 HP (3,0 Kw)
Motor speed	3000 rpm

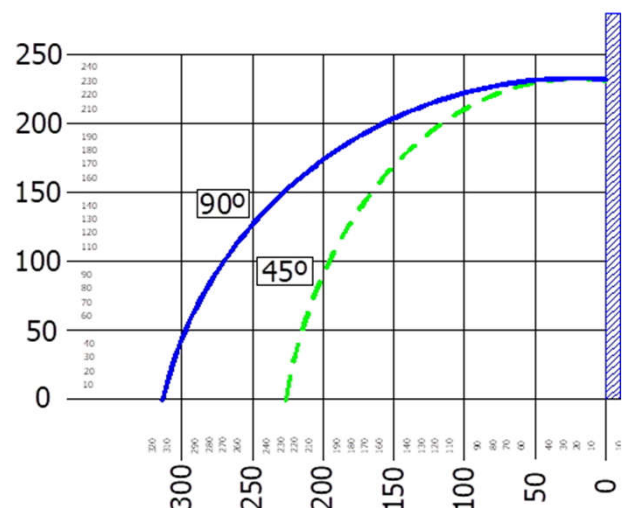

# ALUMINIUM SINGLE BLADE 90° CUTTING



**TL-600-90**

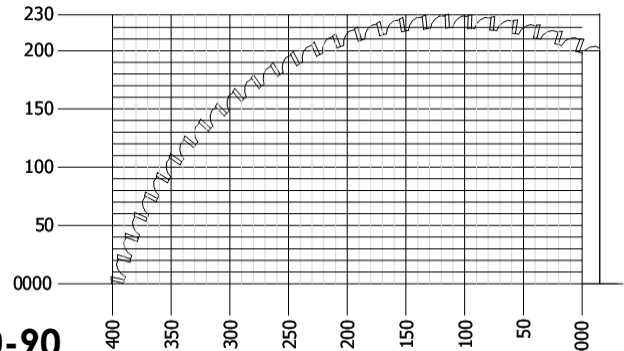

**TL-650-90**

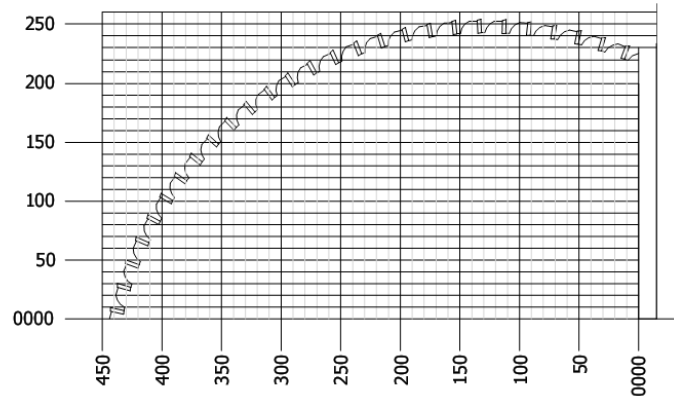

**TL-700-90**

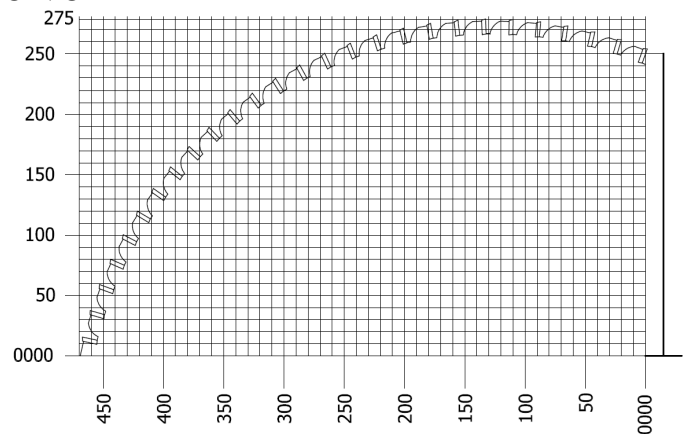

**TL-800-90**

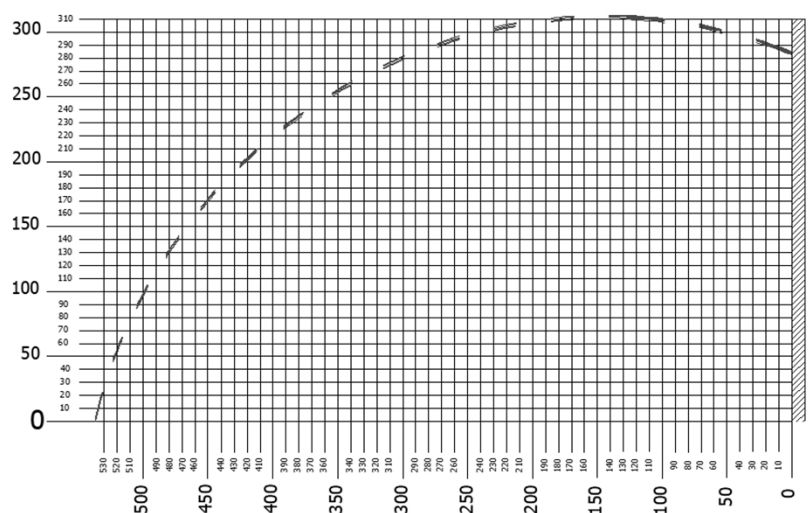

	<b>TL-600-90</b>
Blade Dimensions	600 Ø mm
Motor	5,5 HP (4,0 Kw)
	<b>TL-650-90</b>
Blade Dimensions	650 Ø mm
Motor	7,5 HP (5,6 Kw)
	<b>TL-700-90</b>
Blade Dimensions	700 Ø mm
Motor	7,5 HP (5,6 Kw)
	<b>TL-800-90</b>
Blade Dimensions	800 Ø mm
Motor	10 HP (7,5 Kw)

# ALUMINIUM 90° AUTOMATIC CUTTING

## GAA-350-90

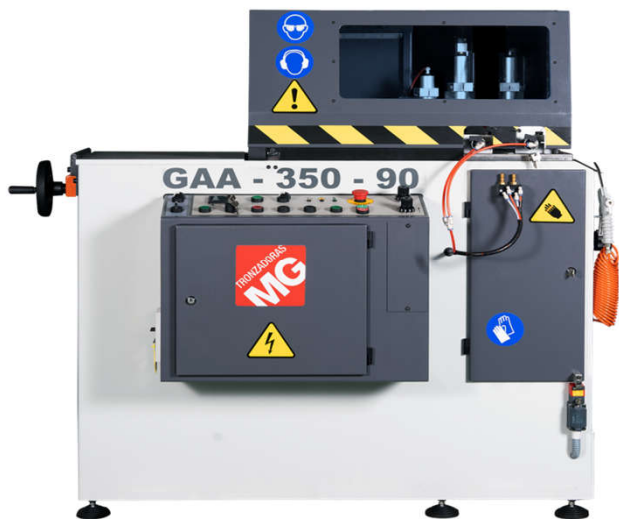

## GAA-500-90



	GAA-350-90
Blade Dimensions	350 Ø mm
Motor	2,5 HP (1,8Kw)
Motor speed	3000 rpm
Feeder length	300 mm
Cutting degrees	90°

	GAA-500-90
Blade Dimensions	500 Ø mm
Motor	4 HP (3Kw)
Motor speed	3000 rpm
Feeder length	500 mm
Cutting degrees	90°

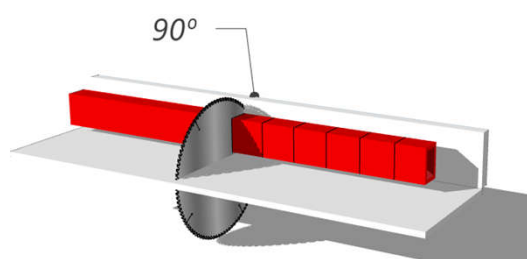
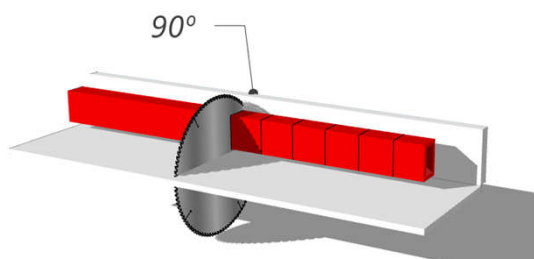

LED illumination incl.  
Automatic hood opening incl.

Options:  
Lubetools mist lubrication  
Automatic start/stop of vaccum cleaner

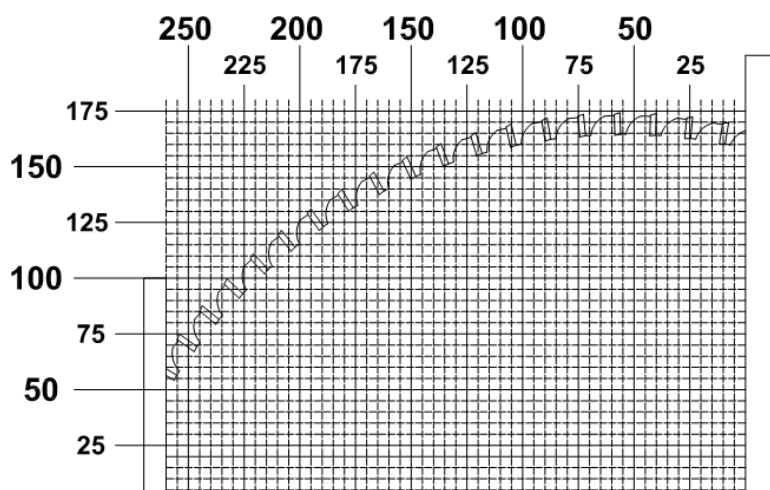
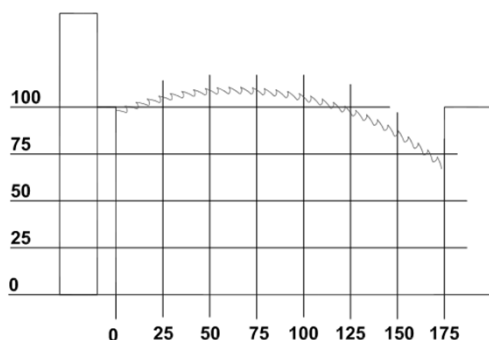

# ALUMINIUM 90° AUTOMATIC CUTTING

## GAA-350-90 CNC



## GAA-500-90 CNC



	GAA-350-90 CNC
Blade Dimensions	350 Ø mm
Motor	2,5 HP (1,8Kw)
Motor speed	3000 rpm
Feeder length	700 mm
Cutting degrees	90°

	GAA-500-90 CNC
Blade Dimensions	500 Ø mm
Motor	4 HP (3Kw)
Motor speed	3000 rpm
Feeder length	700 mm
Cutting degrees	90°

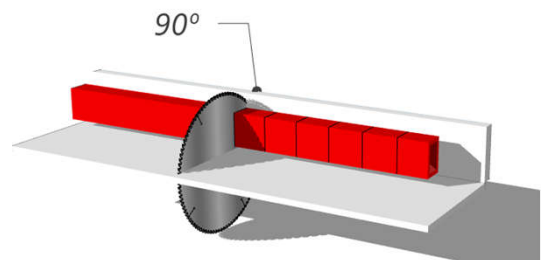
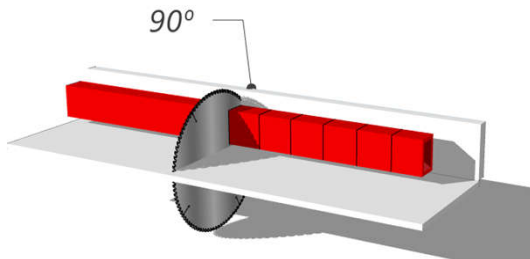

LED illumination incl.  
Automatic hood opening incl.

Options:  
Lubetools mist lubrication  
Blade RPM regulation  
Automatic start/stop of vaccum cleaner  
Ethernet connection

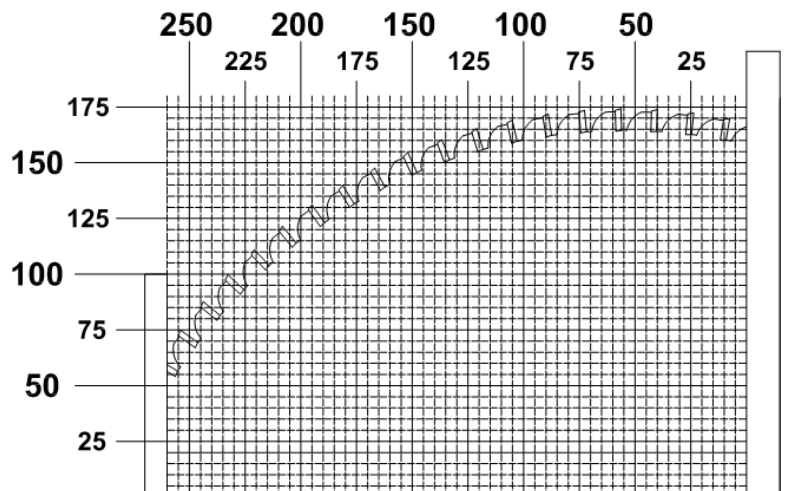
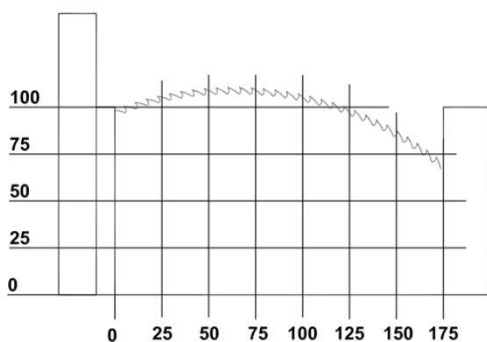

# ALUMINIUM 90° AUTOMATIC CUTTING



## GAA-600-90

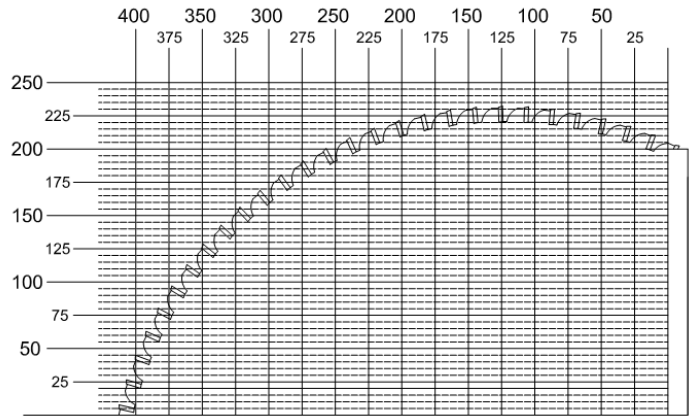

## GAA-650-90

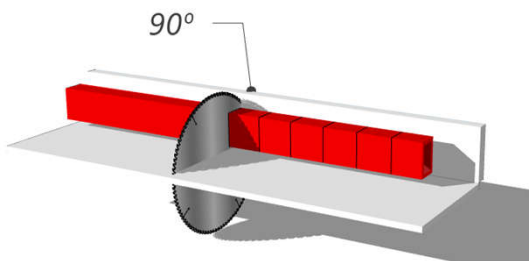
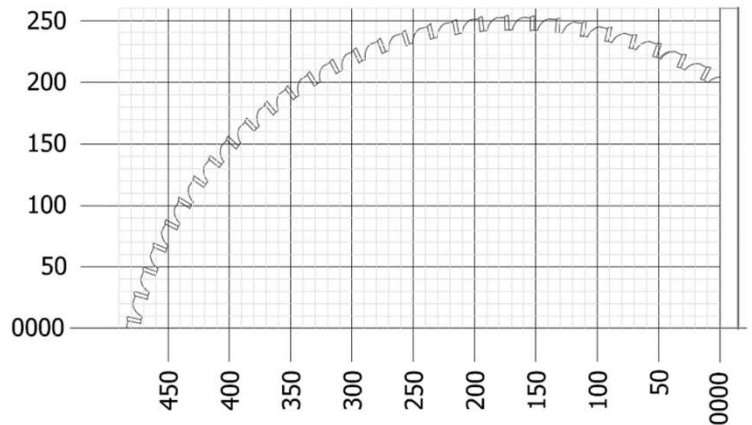

## GAA-800-90

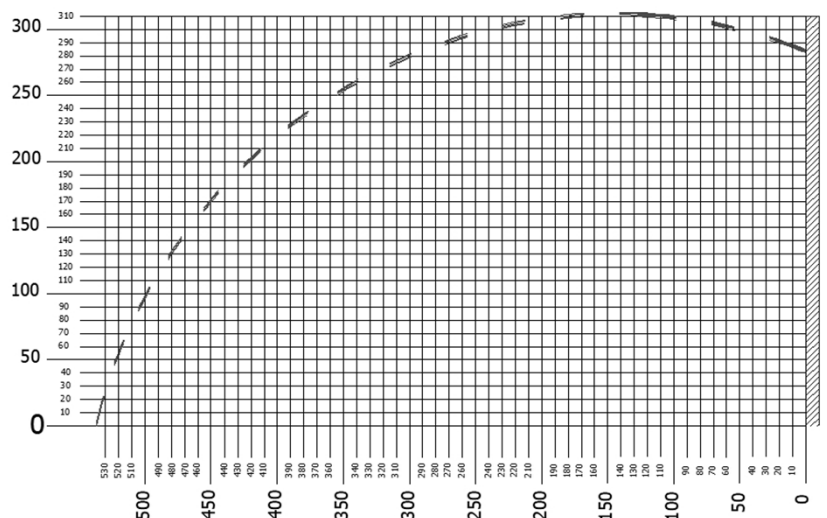

	<b>GAA-600-90 / CNC</b>
Blade Dimensions	600 Ø mm
Motor	5,5 HP (4 Kw)
Feeder length	500 mm / 700mm servo
Cutting degrees	90°

	<b>GAA-650-90 / CNC</b>
Blade Dimensions	650 Ø mm
Motor	7,5 HP (5,5 Kw)
Feeder length	500 mm / 700mm servo
Cutting degrees	90°

	<b>GAA-800-90 / CNC</b>
Blade Dimensions	800 Ø mm
Motor	10 HP (7,5 Kw)
Feeder length	500 mm / 700mm servo
Cutting degrees	90°

# AUTOMATIC PROFILES LOADER FOR GAA MACHINES

## AUTOMATIC LOADER OF PROFILES FOR GAA MACHINES

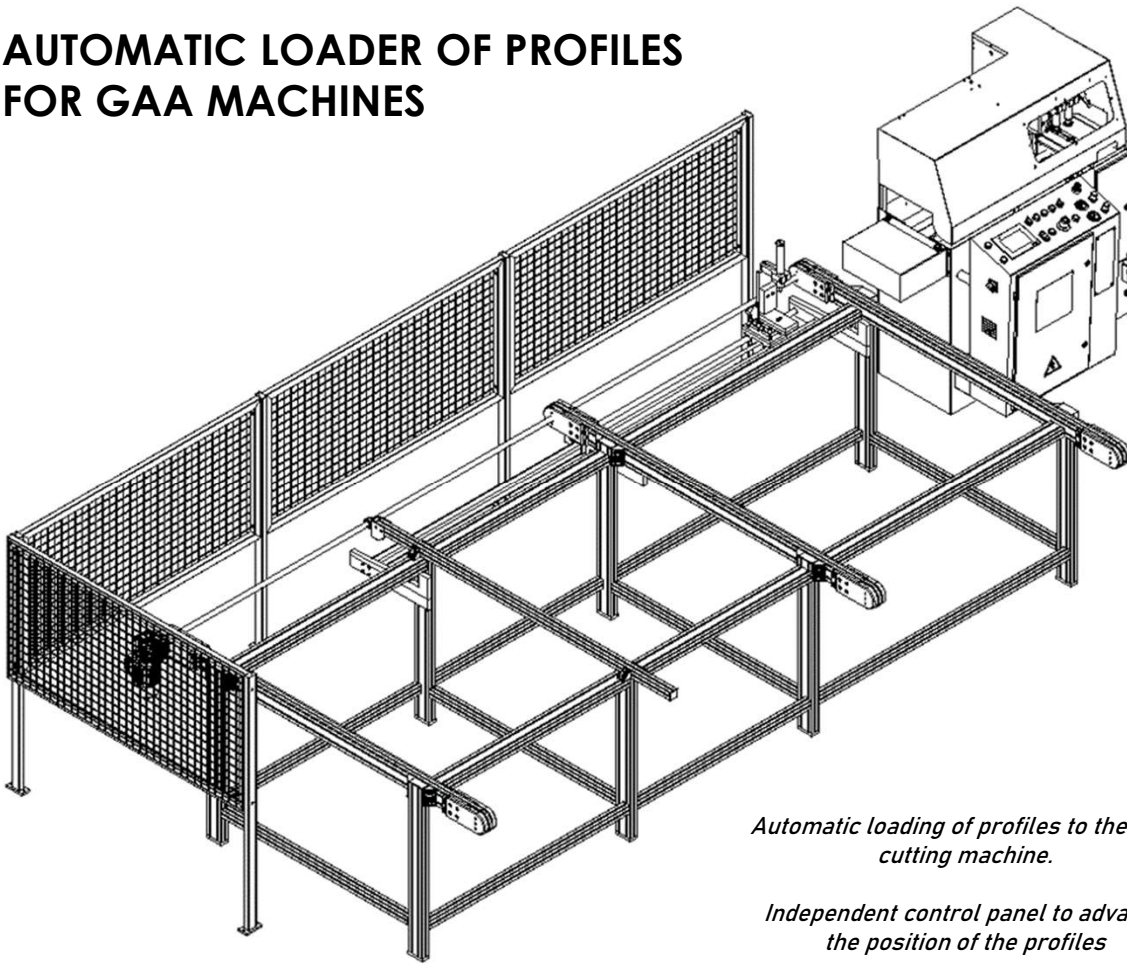

*Automatic loading of profiles to the GAA cutting machine.*

*Independent control panel to advance the position of the profiles*

*Safety fence included with back door for maintenance*

	AUTOMATIC LOADER
Dimensions	6000 x 2000mm standard
Profiles QTY	Average 10

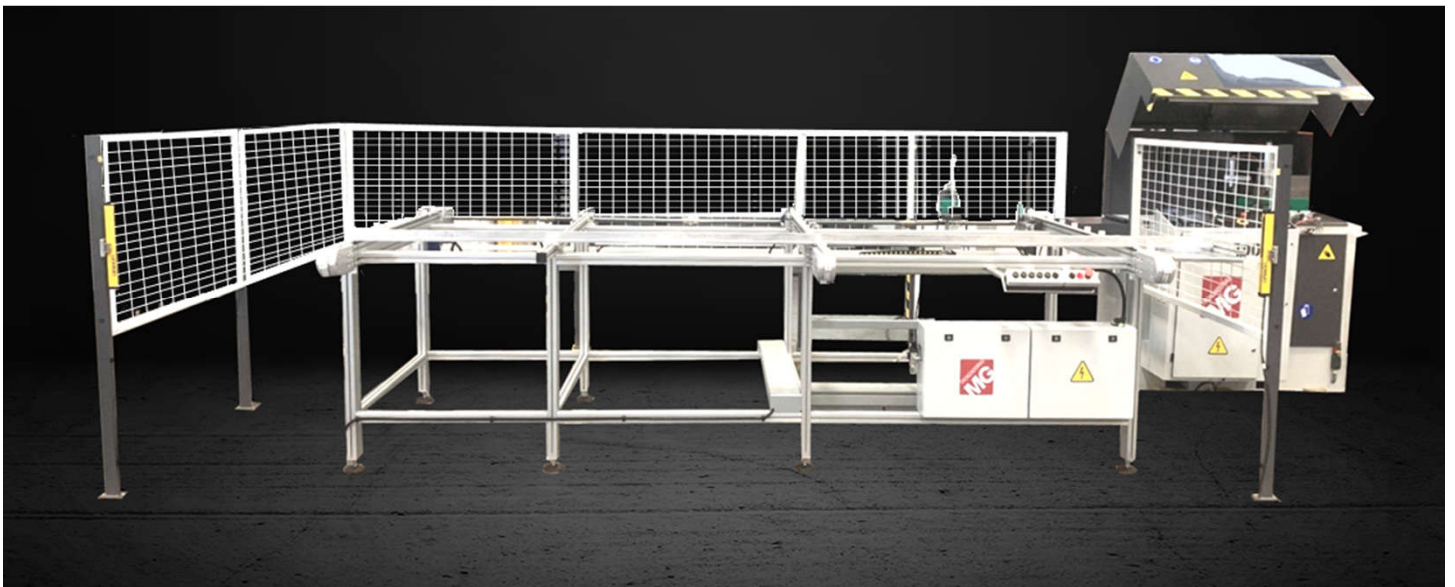

## GAA-350 CNC / TR12

*Automatic CNC Cutting, drilling and tapping Machine with  
one vertical drilling unit for Ø12 mm and M10  
OMRON controllers  
20 Parts in library memory  
10 programs with 30 cutting lines each program  
20 holes drilling per piece  
X axis feeder*

**Options:**

Y axis movement on drilling unit  
TR20 drilling unit for Ø20 mm and M16  
T14 SERVO drilling unit with servo drive

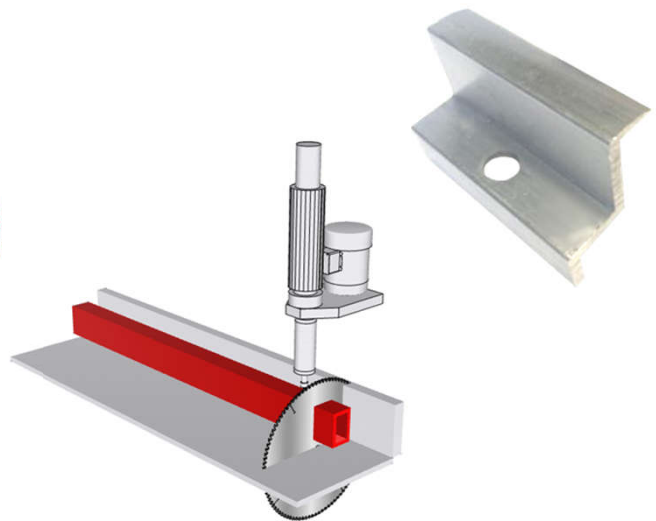

## GAA-350 CNC / TR12 V / TR12 H

*Automatic Cutting, drilling and tapping Machine with one  
vertical drilling unit and one horizontal drilling unit*

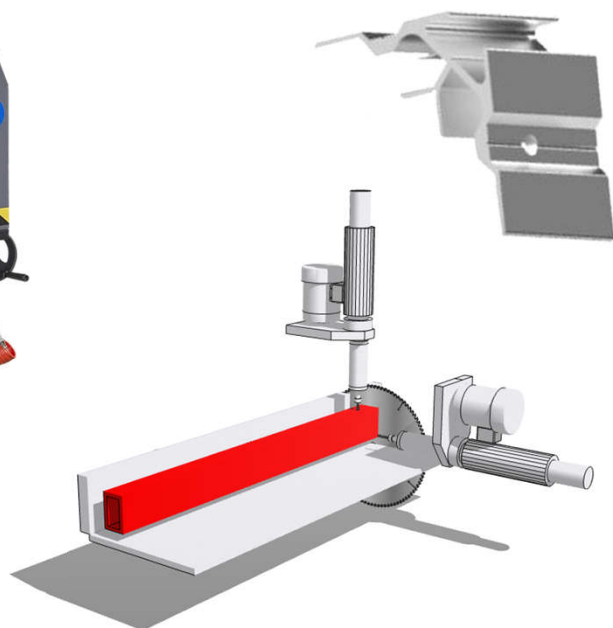



## GAA-350 CNC/TR12 V/TR12 H/TR12 F

*Automatic CNC Cutting, drilling and tapping Machine with one vertical drilling unit, one horizontal drilling unit and Frontal drilling unit*

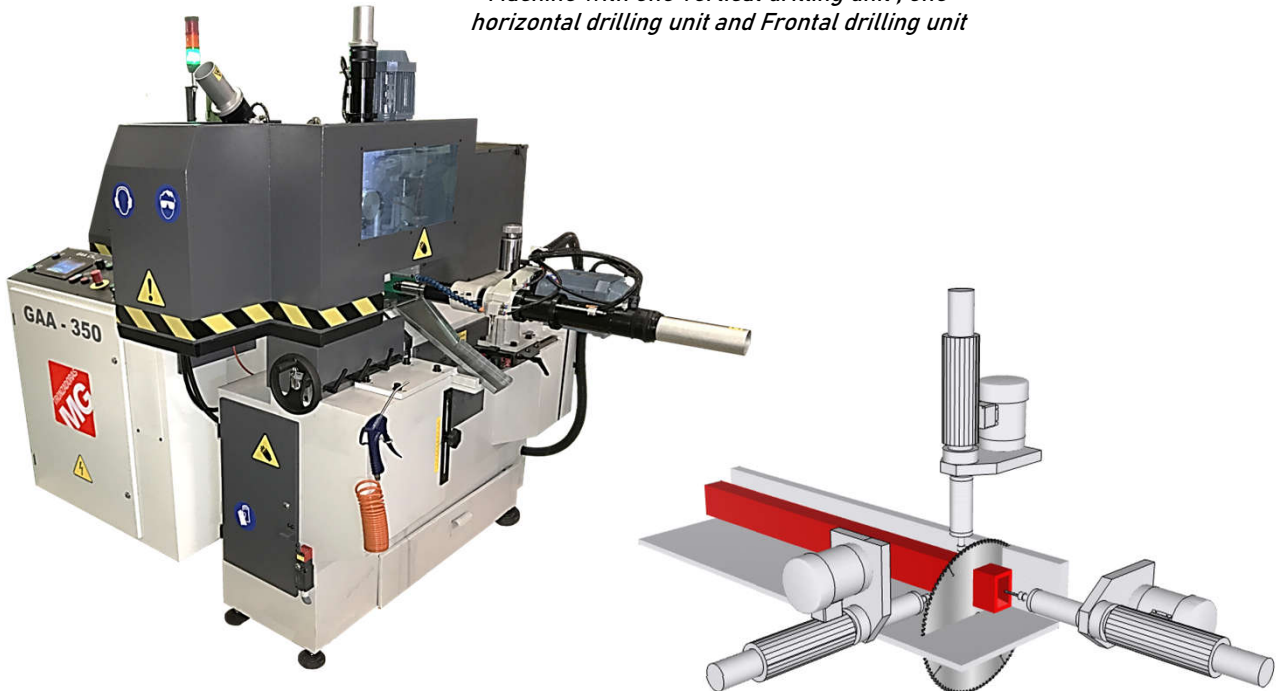

## GAA-350 CNC/TR12 V+Y /TR12 H+Z

*Automatic CNC Cutting, drilling and tapping Machine with SERVO X axis feeder, one vertical drilling unit with SERVO Y axis movement and one horizontal drilling unit with SERVO Z axis movement*



## GAA-500 CNC / TR12 H / TR12 H

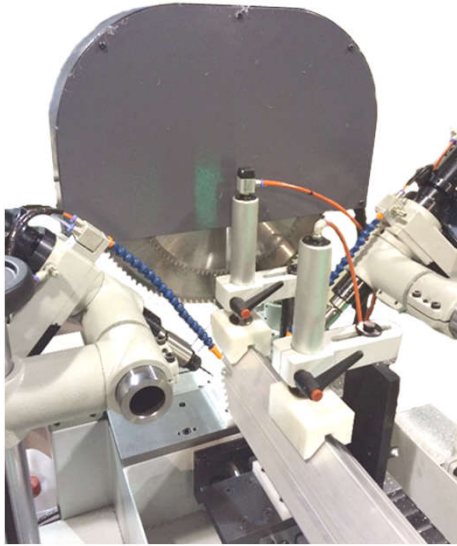

*Special CNC cutting and drilling Machines specially made for custom parts*

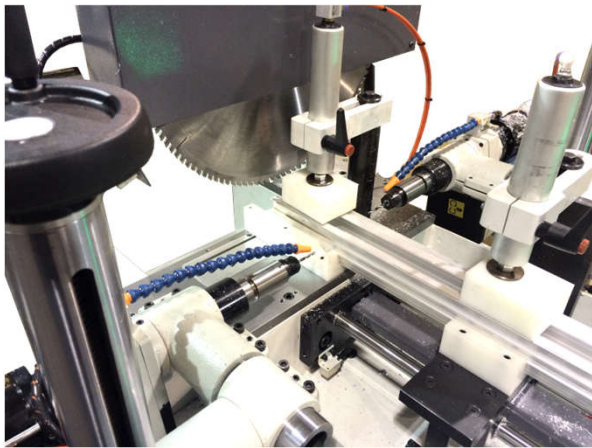

*Automatic CNC Cutting, drilling and tapping Machine with one vertical drilling unit, and two horizontal adjustable units*

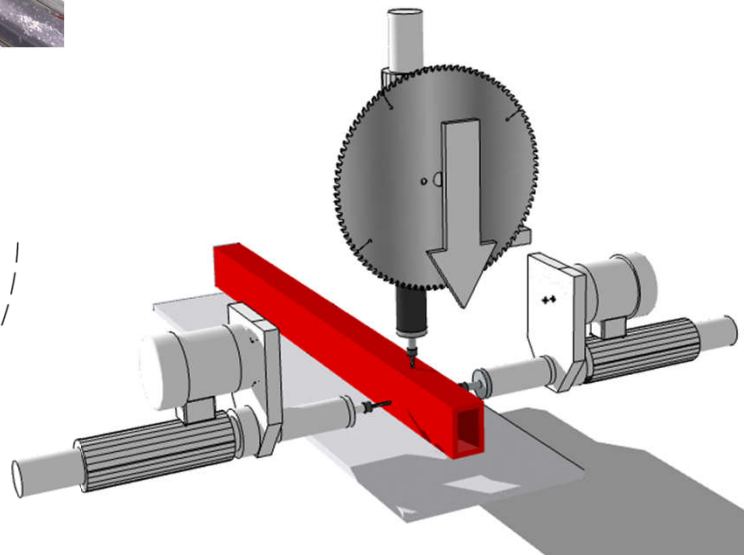
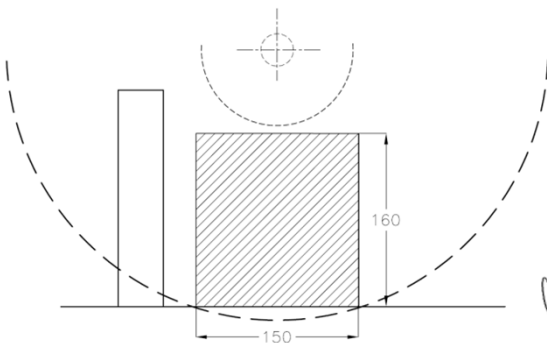

# DOUBLE MITER CUTTING MACHINE

## DUO-450 / DUO-550

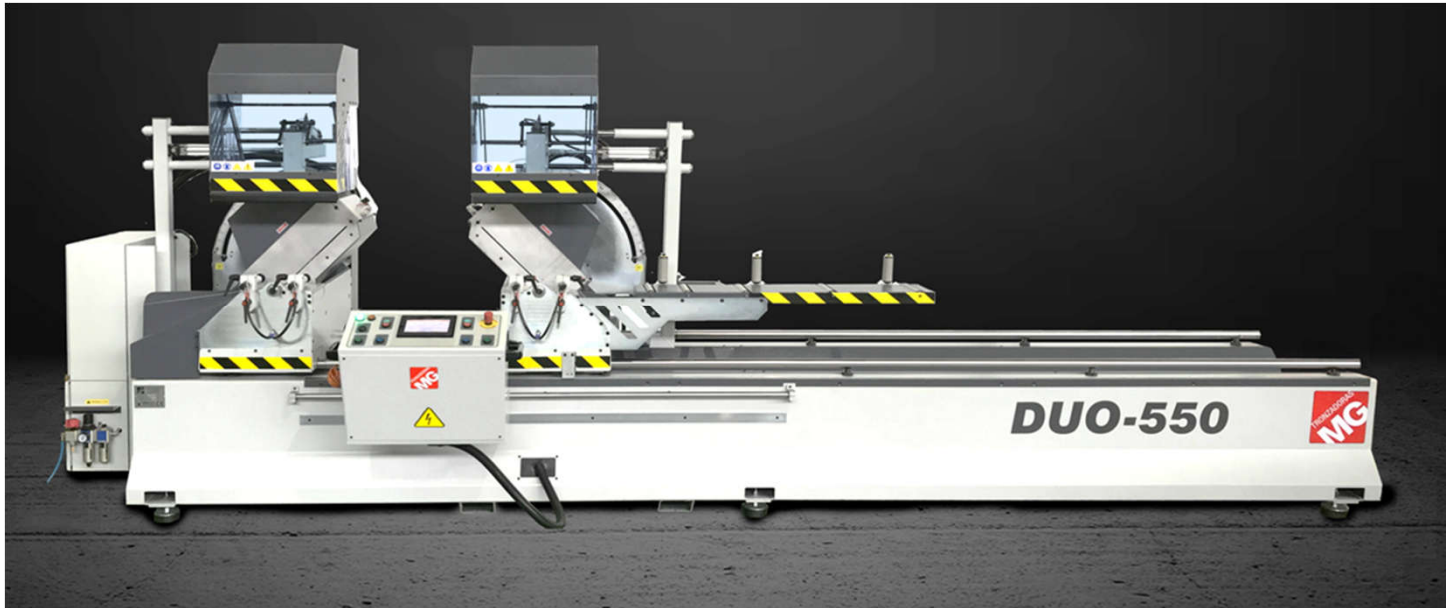

	DUO-450		DUO-550
Blade Dimensions	450 Ø mm	Blade Dimensions	550 Ø mm
Cutting degrees	-45°/ 90°/ 45°	Cutting degrees	-45°/ 90°/ 45°
Weight of the machine	1400 kg	Weight of the machine	1600 kg

-45° / 90° / +45°  
PNEUMATIC

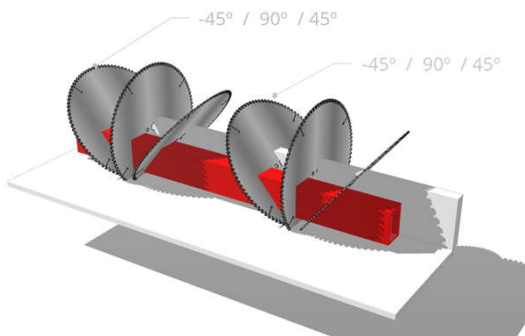

950mm longer cut part  
5mm smaller cut part

Four working modes:  
AUTOMATIC MODE  
SEMI-AUTOMATIC MODE  
MANUAL MODE  
STEP BY STEP CUTTING MODE

Options:  
Profile height caliper  
Label Printer  
Barcode Scanner

-45° / 90° / +45°  
PNEUMATIC

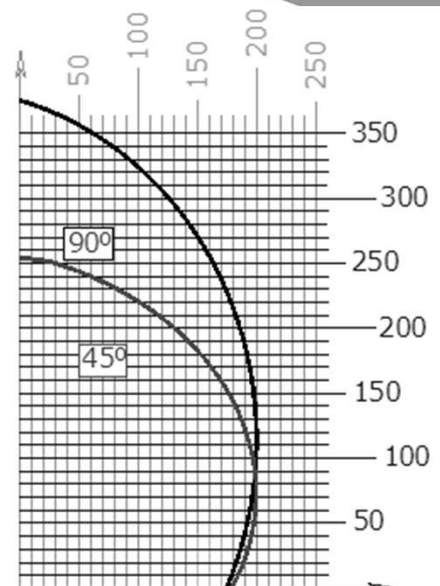
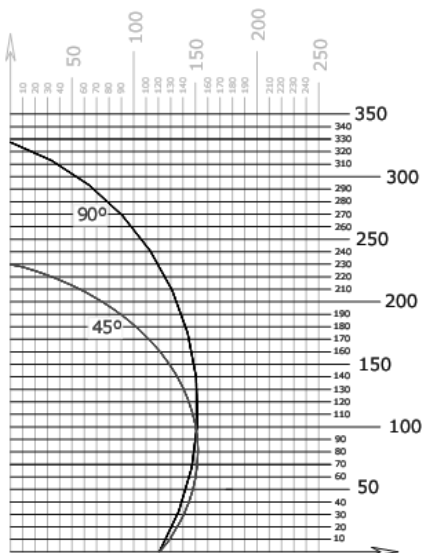
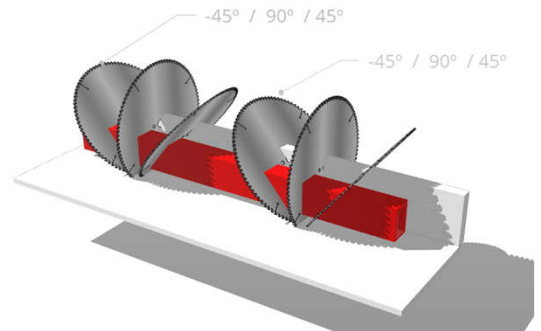

# MG-3300/4

## 4-Axis Machining Center



4axis machining center  
 5,5 Kw HITECO with spindle rotation of 18000rpm  
 5mm Aluminium / 3mm Steel

X4 pneumatic clamping  
 4 tools magazine ( option 8)  
 HICAM3 CAD/CAM 3D design

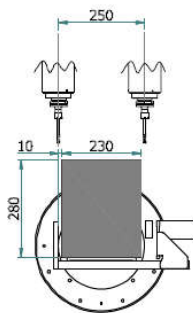

ONLY AT 0° INSIDE THE RINGS

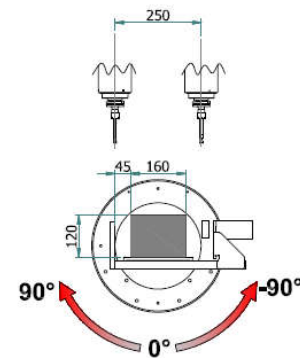

THROUGH THE RINGS

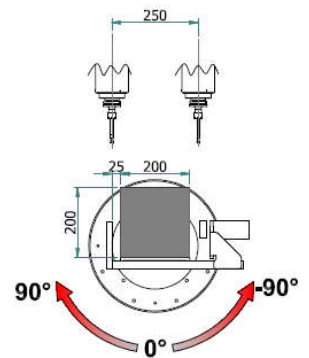

INSIDE THE RINGS

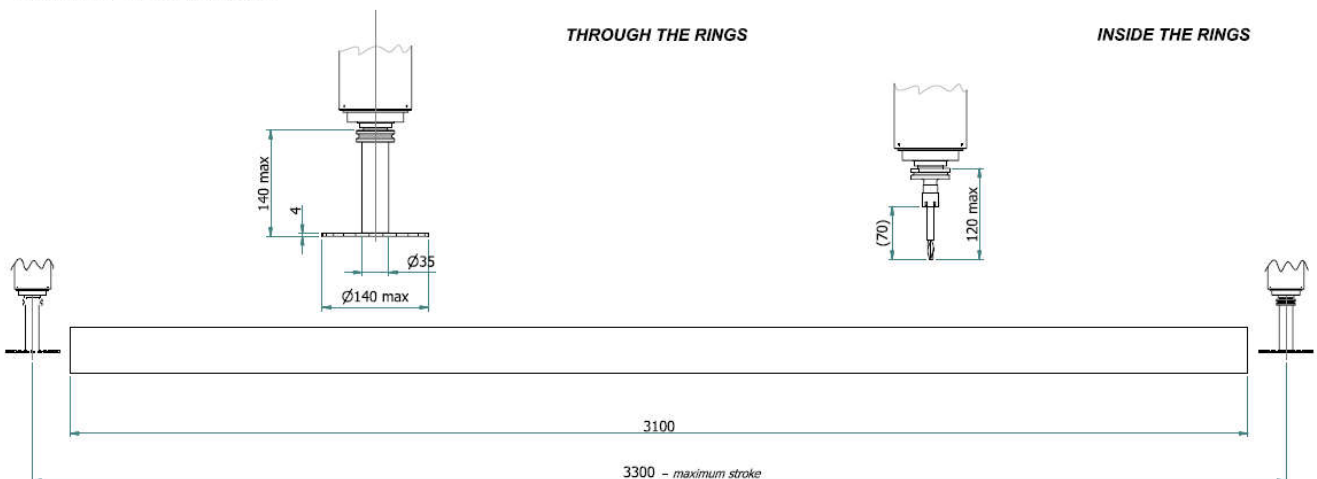

## MG-3300/4

## 4-Axis Machining Center

### FEATURES

- Possibility to work aluminum, PVC, steel up to 5 mm and stainless steel up to 3 mm with accessory
- Axis movement and clamps rails with recirculating ballscrew and servodrive
- Motion rotated clamp base by rail and wheels
- Numerically controlled axes with 4 brushless motors
- Transmission axis with tilted teeth rack and pinion
- Start cycle with two-handed safety device
- 4 pneumatic horizontal pneumatic clamps with low pressure device
- Mist lubrication
- Tool magazine ISO30
- Automatic tool change with station for 4 tools (optionally 8 tools)
- 5,5 Kw Spindle motor driven by inverter
- USB 2.0 port on the control panel and ethernet RJ45 socket
- Preinstalled barcode reader connection
- NC - Industrial PC with Intel microprocessor
- LCD display - TFT (800 x 600) color 10.4 "
- Operating system Windows XP Embedded RT
- HICAM 3 Software- 3D dimensional

### TECHNICAL DATA

Power (3 phase+neutral)	380/400-50/60	Volt/Hz
Spindle motor	5.5	Kw
Spindle speed range	2000...18000	rpm
Axis positioning range X-Y-Z	3300 -250-200	mm
Axis positioning speed X- Y-Z	65-25-25	m/min
Tilt axis adjustable clamp	-90°...+90°	°
Axis time rotation from 0 .. 90 °	2	Sec
Axis positioning tolerance	3 +/- 0.1	mm
Clamping capacity (bxh)	160x120	mm
Max. milling blade diameter	140	mm
Weight	1550	Kg

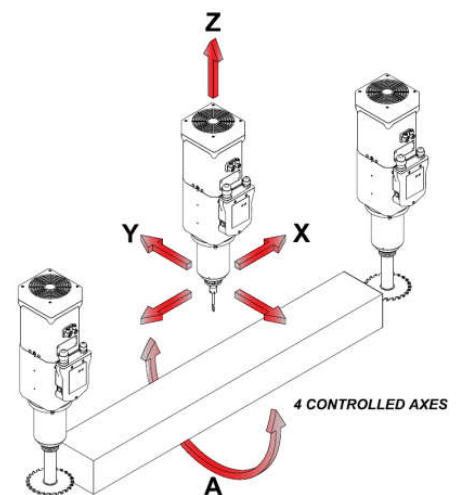

### OPTIONS

- Automatic vice clamping positioning
- Tooling Station for 4 tools (right side)
- Barcode reader with wire and software
- Tunnel torque L = 500 Top
- Cover complete with windows and two mouths D.100 fume Extraction License
- HICAM license USB for PC ( not used simultaneously with the machine)
- Additional license CAD / CAM three-dimensional HICAM 3 with USB
- Connectivity to ORGADATA, FENETECH, OPERA, \*.ncw, \*.cms, \*.ecw, \*.ncx

# POSITIONING SYSTEMS / ROLLER CONVEYORS

## E-3



E-3 / E-4 / E-6 / E-8 ROLLER CONVEYOR

## TM-3



TM-3 / TM-4 / TM-6 / TM-8  
MANUAL CLAMPING VERSION

## TMDG-3



TMDG-3 / TMDG-4 / TMDG-6 / TMDG-8  
MANUAL CLAMPING VERSION  
Linear encoder and Digital display

## TN-3



TN-3 / TN-4 / TN-6 / TN-8  
PNEUMATIC CLAMPING VERSION

## TNDG-3



TNDG-3 / TNDG-4 / TNDG-6 / TNDG-8  
PNEUMATIC CLAMPING VERSION  
Linear encoder and Digital display



TM / TN / TMDG / TNDG	3m	4m	6m	8m
Height of table	800-1050mm			
PVC rollers	11	14	20	26
Permissible load	20 Kg /meter			
Positioning accuracy	±0,1mm	±0,2mm	±0,2mm	±0,3mm

# AUTOPOS

*The AUTOPOS is a motorized positioning System with linear encoder  
Color Touch screen panel  
20 lines cutting list*

**AUTOMATIC - CUTTING LIST  
SEMIAUTOMATIC  
MANUAL**

*Options:  
Barcode Scanner  
Label Printer*



# AUTOPOS + USB

*AUTOPOS with  
USB CONNECTION OPTION  
CSV files accepted  
Options:  
Barcode Scanner  
Label Printer*



# PUSHER AUTOPOS

*The PUSHER AUTOPOS is a motorized feeder that can be attached to any TL or TLG Machine*

*It synchronizes the automation with the clamping and blade cutting of the Machine*

*The PUSHER AUTOPOS accepts cutting list and Works in three modes:*

**AUTOMATIC - CUT LIST  
SEMIAUTOMATIC  
MANUAL**

*Option:  
Pneumatic gripper  
Barcode scanner*



*PUSHER AUTOPOS FERRO  
Intended for heavy profiles*



# COPY ROUTERS FOR ALUMINIUM / PVC

## C-452-M



## C-452-SA

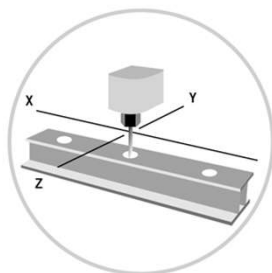
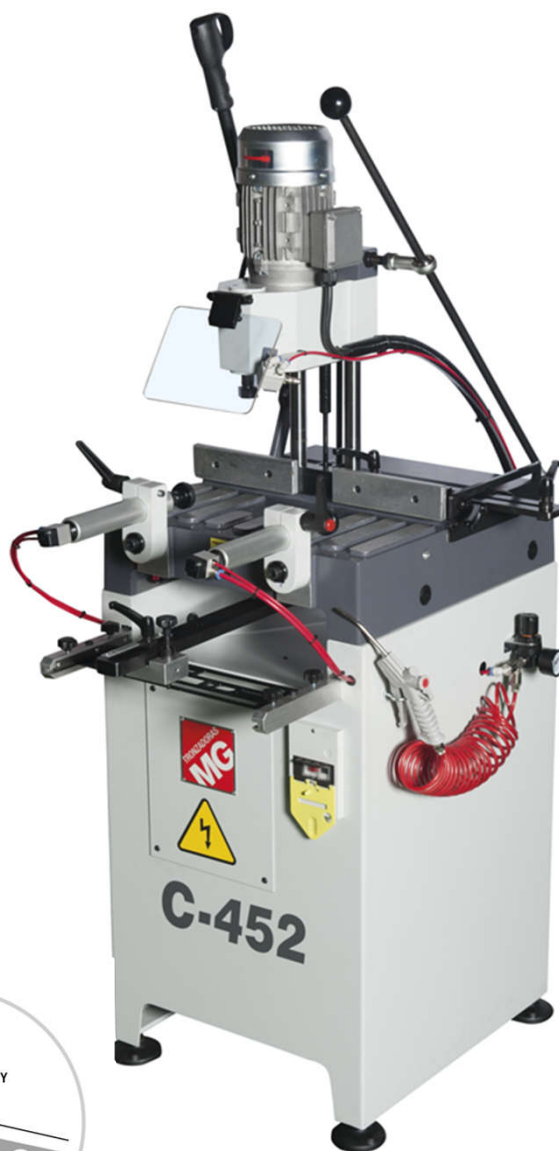

5 $\emptyset$  / 8 $\emptyset$

	C-452-M / SA
Desk Size	450 x 230 mm
Longitudinal course	230 mm
Transversal course	110 mm
Vertical displacement	145 mm
Motor	0,5 HP
Cutting speed	9600 rpm
Diameter milling cutter	8 mm
Weight	120 Kg

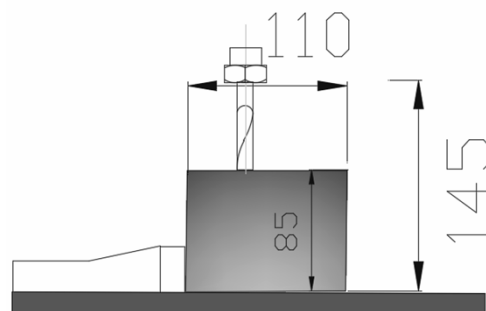



# C-500-A / AH



*C-500 COPY MILLING MACHINE with two templates installed at the upper side*

*Easy patern change by pneumatic operated pin from the working handles*

*C-500 AH including spindle speed regulation for milling 3mm steel*

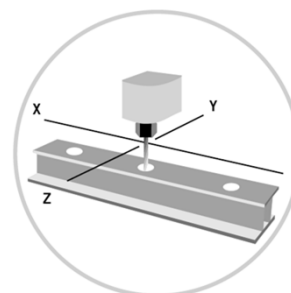

5 $\emptyset$  / 8 $\emptyset$

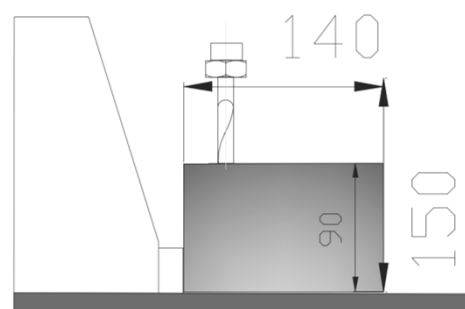

	C-500-A	C-500-AH
Desk Size	500 x 280 mm	500 x 280 mm
Longitudinal course	260 mm	260 mm
Transversal course	140 mm	140 mm
Vertical displacement	150 mm	150 mm
Motor	2 HP	2 HP
Cutting speed	9000 rpm	2000-7000 rpm
Diameter milling cutter	8 mm	8 mm
Weight	150 Kg	150 Kg

## MINI RAFRE-SA



*Portable corner milling Machine  
Pneumatic clamping  
Pneumatic lubrication*

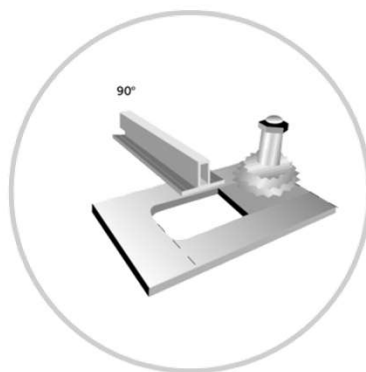

## MINI RAFRE-M



*Portable corner milling Machine  
Manual clamping  
Manual pumping lubrication*



	MINI RAFRE -M / SA
Motor	2,75 HP
Motor speed	3000 rpm
Motor shaft	27 mm
Milling cutter inner Ø	32 mm
Milling cutters max Ø	120 mm
Course	200 mm
Dimensions	410x400x330 mm
Weight	48 Kg



# END MILLING MACHINES FOR ALUMINIUM / PVC

## RAFRE-CR M



*RAFRE CR-M  
Manual clamping  
Manual pumping lubrication  
Manual advance of blades*

## RAFRE-CR SA



*RAFRE CR-SA  
Pneumatic clamping  
Pneumatic lubrication  
Manual advance of blades*

## RAFRE-CR A



*RAFRE CR-A  
Pneumatic clamping  
Pneumatic lubrication  
Pneumatic advance of blades*

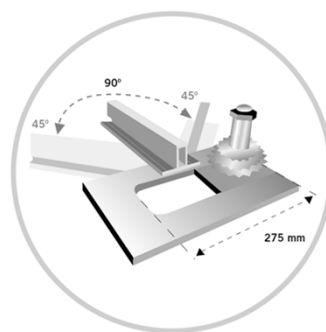

	MINI RAFRE -M / SA / A
Motor	2,75 HP
Motor speed	3000 rpm
Motor shaft	27 mm
Milling cutter inner Ø	32 mm
Milling cutters max Ø	140 mm
Course	275 mm
Dimensions	630x515 mm
Weight	150 Kg



# PRESSES FOR ALUMINIUM PROFILES

## P-3000-G



## P-3300-G



## P-4000-G



## P-8000-G



	P-3000-G	P-3300-G
Max pressure	3000 Kg at 8 ATM	3300 Kg at 8 ATM
Pneumatic pressure	6-8 ATM	6-8 ATM
Light	260 mm	250 mm
Course	35 mm	20-80 mm
Pin speed	23 mm/seg	35 mm/seg
Average air consume x cycle	25 l	35 l
Desk	530 x340 mm	375x230 mm
Height	260 mm	250 mm
Ø of the cylinder	45 mm	45 mm
Weight	75 Kg	60 Kg

	P-4000-G	P-8000-G
Max pressure	4000 Kg at 8 ATM	8000 Kg at 8 ATM
Pneumatic pressure	6-8 ATM	6-8 ATM
Light	250 mm	250 mm
Course	0-50 mm	0-50 mm
Pin speed	32 mm/seg	32 mm/seg
Average air consume x cycle	32 l	32 l
Desk	375 x235 mm	440x260 mm
Ø of the cylinder	45 mm	125 mm
Weight	130 Kg	150 Kg

## ASSEMBLY TABLES

### B-4000-L



*The B-4000-L is a Windows assembly table designed to offer a great working surface to where the operator can easily assemble the profiles and accessories*

*2 spoolers for rubber  
4 storage boxes  
6 pneumatic connection points for tools  
6 electrical plugs  
1 air cleaning gun*

	B-4000-L	B-4000-HV
Dimensions	4000x2000 mm	4000x2000 mm
Weight	162 Kg	230 Kg

### B-4000-HV

*The B-4000-HV is a Windows assembly table designed to offer a great working surface to where the operator can easily assemble the profiles and accessories working in horizontal or in vertical position*

*10 extending modular arms  
2 spoolers for rubber  
5 storage boxes  
6 pneumatic connection points for tools  
1 air cleaning gun*



## CPP-4100

*The CPP-4100 is ideal to move the long six meter profiles from the reception area into the profile storage shelves or to the cutting lines*

*4100mm long  
1000Kg loading capacity  
98 Kg*



## CHP-1730

*The CHP-1730 is ideal to move the cut profiles from the cutting line to the Assembly area*

*450Kg load capacity*



## CV-9

*The CV-9 is designed to properly position up to nine finished Windows frames for storage or for transportation to the storage area*

*400Kg load capacity  
9 x 100mm compartments*



## V460 / VORTEX 58/ V570

	V-460 1.5 1200
Motor	2 HP
Sound level	64 dB
Inlet Diameters	1x 100 mm
Suction capacity	1200 m <sup>3</sup> /h
Storage Capacity	100 m <sup>3</sup>

	VORTEX 58
Motor	3 HP
Sound level	64 dB
Inlet Diameters	2x 100 mm
Suction capacity	1400 m <sup>3</sup> /h
Storage Capacity	160 m <sup>3</sup>



	V-570 3 2500
Motor	4 HP
Sound level	64 Db
Inlet Diameters	2x 160 mm
Suction capacity	2500 m <sup>3</sup> /h
Storage Capacity	160 m <sup>3</sup>

*Efficient and powerful Vacuum cleaner for Aluminium chips including an integrated container with wheels*

# VORTEX 600



	VORTEX 600
Motor	4 kW
Suction capacity	4000 m <sup>3</sup> /h

*Efficient and powerful Vacuum cleaner for Aluminium chips in continuous operation. Ideally suited to GAA automatic cutting Machines with Automatic Loader of profiles*



# CORNER CRIMPING MACHINE / PROFILES BENDING MACHINE

## L-110



	L-110
Max. Crimping force	3500 Kgp
Knives max. stroke	10,5 mm
Bracing clamp stroke	80 mm
Max crimping height	120 mm
Operating crimping regulation	30 to 60 mm
Pneumatic nominal pressure	7 Bar
Weight	300 Kg

## C-3/50



	C-3/50
Bending Shafts Ø	50 mm
Central roller max Ø	100-150 mm
Motor	1-1,5 HP
Motor Speed	1500 -3000rpm
Rotations x min	10/20 rpm
Min bending Ø	500 mm
Weight	180 Kg

	60 x 12		60 x 40 x 4 60 x 60 x 3
	80 x 20		Ø 60 x 3 Ø 70 x 2
	40		60 x 60 x 5
	Ø40		
	60 x 50 x 5		60 x 40 x 5



**TRONZADORAS MG,S.A.**  
Pol.Ind. Font de la Parera  
La Roca del Valles - 08430  
Barcelona - Spain  
T.+34 938424160  
info@tronzadorasmg.com  
www.tronzadorasmg.com

*Tronzadoras MG reserves the right to perform any modification in this catalogue for technical or commercial purposes*

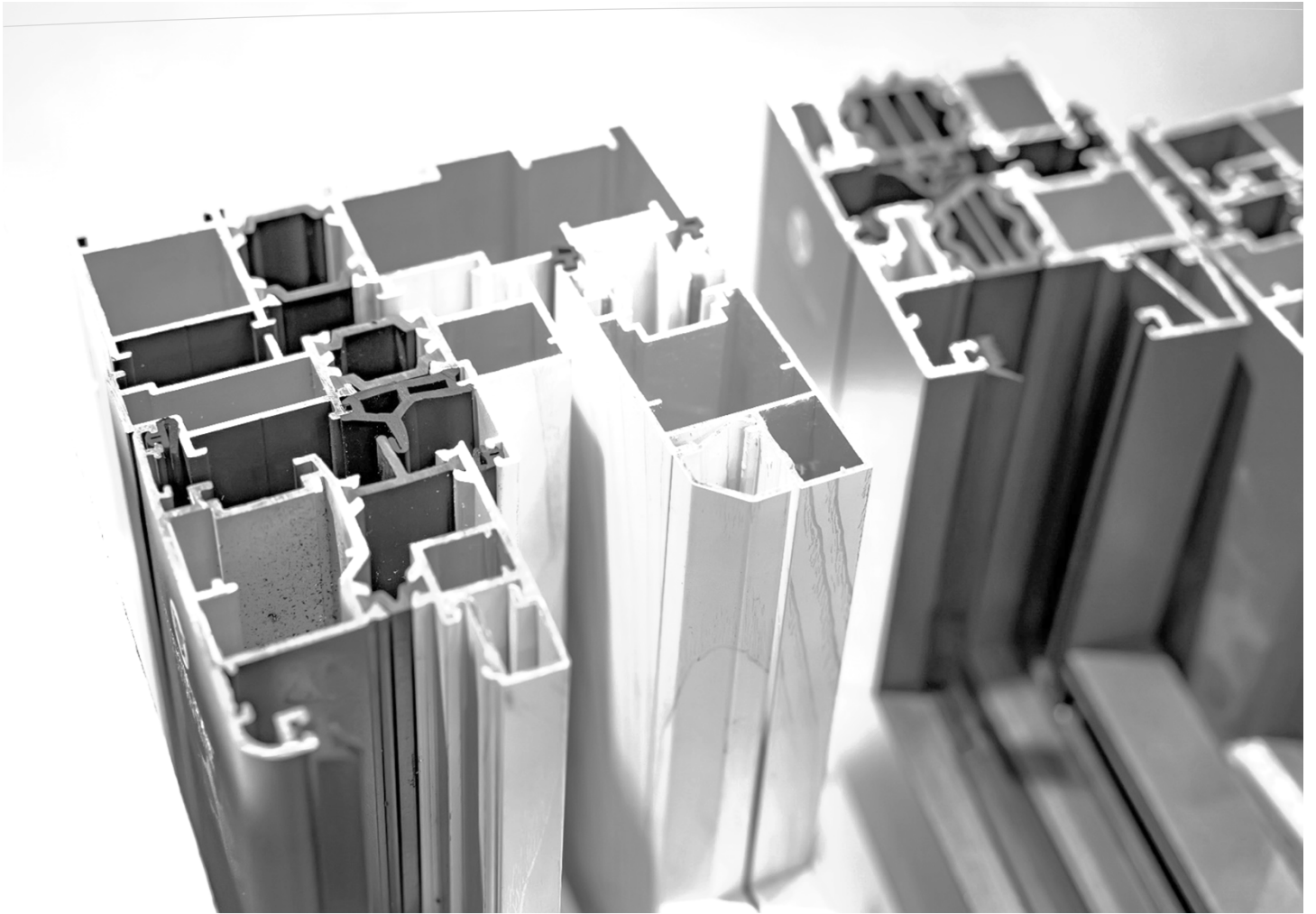

MADE  
SPAIN