

- 1.*For information only.
- 2. Non mentioned tolerances - holes H16, shafts h16, other ±IT16/2.
- 3. Not mentioned surface roughness Ra 12,5 µm.
- 4. Mark (punched in) tanks serial numbers (acc. to customer): V1448 - V 453

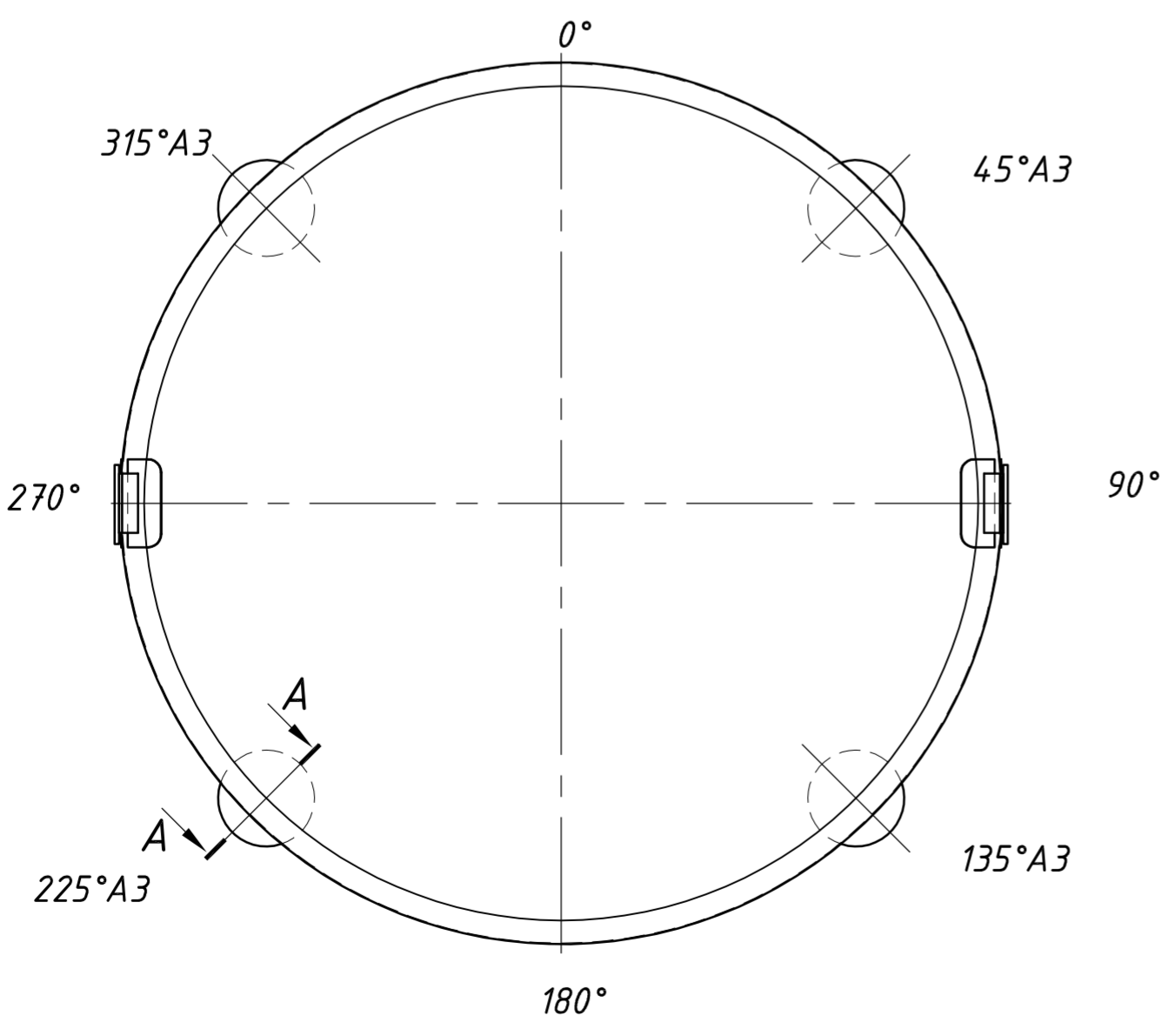

Welding data	Welds		Nondestructive examination				Remarks				
	Longitudinal welds	0,7	VT 100%								
	Circumferential welds	0,7									
Other welds	0,7										
Quality level for vessel weldings seams defects - C acc. LST EN ISO 5817 : 2014 requirements											
Nozzle data	No	Description	Q-ty	Positioning	Flange		Type	Facing	Remarks		
					SMS/DN	PN	ASME / DIN				
	A2	Lifting lugs	2	90°;270°	—	—	—	—		—	
A3	Legs	4	45°;135°;225°;315°	—	—	—	—	—	φ219,1x3,0		
Material data	Description				Tank						
	Shell and top head				1.4404 EN 10088-2						
	Bottom head and outer room				1.4404 EN 10088-2						
	Supports				1.4301 EN 10217-7						
	Nozzle pipes				—						
	Nozzles				—						
	Seals				—						
	External bolts & nuts				—						
Internals				—							
Reinforcement plates				—							
VTM-10.00.000SB											
Ch.	Sheet	Dokum. Nr.	Signatur	Date	Tank 10 m³				Letter	Mass	Scale
				20.03.12							
										Sheet 1	Sheet nr. 1
										Rev.1	
										20.03.12	