

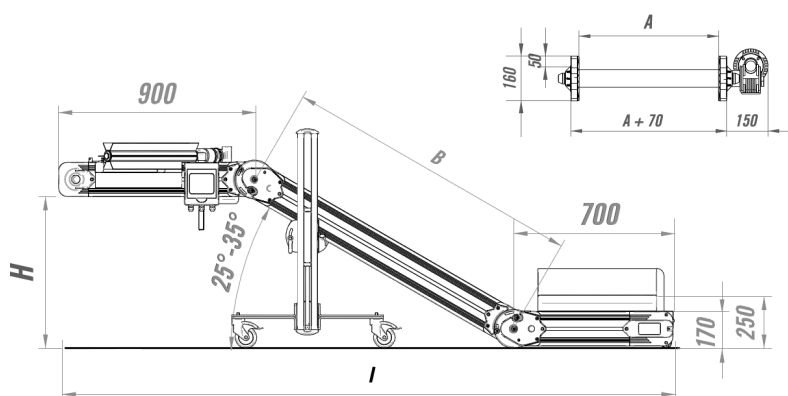

### TECHNICAL FEATURES

- Aluminium NON-REMOVABLE side panels, h 50 mm
- Cut-proof, oil-proof belt, with high grip grey PVC covering; vulcanized belt joint.
- Temperature resistance:  
Continuous: from -10°C to +60°C
- NORD transmission group 0.12 kW three-phase, asynchronous motor + kW 0,09 for the separator + worm reduction unit with permanent lubrication
- Fixed standard speed: 3,5 m/min
- Start/Stop switch with 5 m cable
- Voltage: 400V / 3-fase / 50Hz



	A	B	H min	H max	I at 30°
N-CPST.1	240 mm	1300 mm	550 mm	750 mm	2850 mm
N-CPST.2	340 mm	1800 mm	750 mm	1000 mm	3250 mm
N-CPST.3	440 mm	1800 mm	750 mm	1000 mm	3250 mm



### TECHNICAL FEATURES

- Aluminium NON-REMOVABLE side panels, h 50 mm
- Belt: antistatic, cut-proof and oil-proof, with smooth grey Polyurethane covering.
- Slats H=30mm / Pitch 400mm.
- Belt thickness 1,7 mm
- Temperature resistance:
- Continuous: from -10°C to +90°C
- Momentary: from -30°C to +110°C
- NORD transmission group 0.12 kW three-phase, asynchronous motor + worm reduction unit with permanent lubrication
- Fixed standard speed: 3,5 m/min
- Start/Stop switch with 5 m cable
- Voltage: 400V / 3-fase / 50Hz

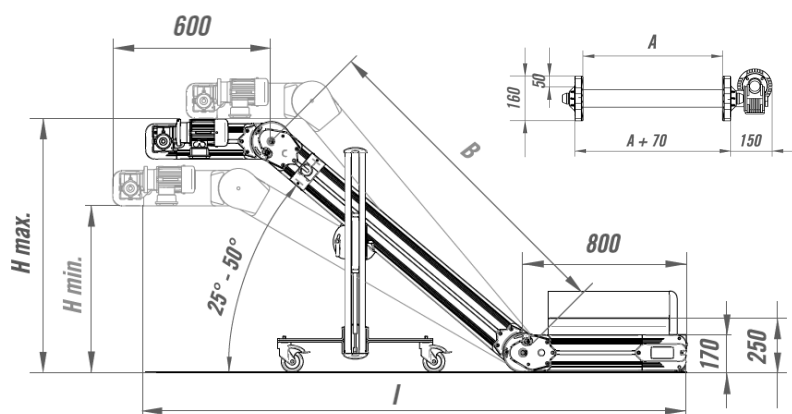

	A	B	H min	H max	I at 40°
N-CPTR.1	240 mm	1500 mm	600 mm	1100 mm	2500 mm
N-CPTR.2	340 mm	1800 mm	700 mm	1350 mm	2750 mm
N-CPTR.3	440 mm	2000 mm	800 mm	1500 mm	2900 mm
N-CPTR.4	540 mm	2000 mm	800 mm	1500 mm	2900 mm



## TECHNICAL FEATURES

- Structure made of aluminium anodized profile height 120 mm with NON-REMOVABLE side panel h= 35 mm
- Belt: antistatic, cut-proof and oil-proof, with smooth grey Polyurethane covering.  
Slats H=30mm / Pitch 400mm.  
Belt thickness 1,7 mm
- Temperature resistance:  
Continuous: from -10°C to +90°C  
Momentary: from -30°C to +110°C
- Standard transmission group composed of three-phase motor, worm reduction unit with lubrication for life
- Fixed standard speed ~3 m/min
- Start/Stop switch with 5 m cable
- Voltage: 400V / 3-fase / 50Hz

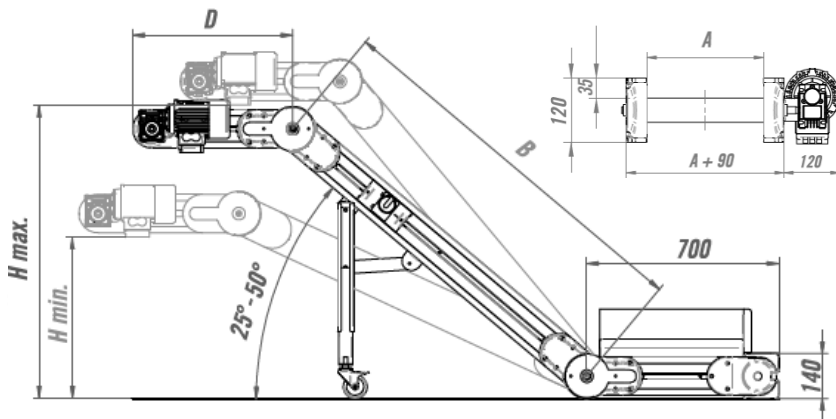

	A	B	H min. (25°)	H max. (50°)
Smart CPT 0	155 mm	1500 mm	550 mm	1100 mm
Smart CPT 1	255 mm	1500 mm	550 mm	1100 mm
Smart CPT 2	355 mm	1800 mm	700 mm	1300 mm