

aerospace  
climate control  
**electromechanical**  
filtration  
fluid & gas handling  
hydraulics  
pneumatics  
process control  
sealing & shielding

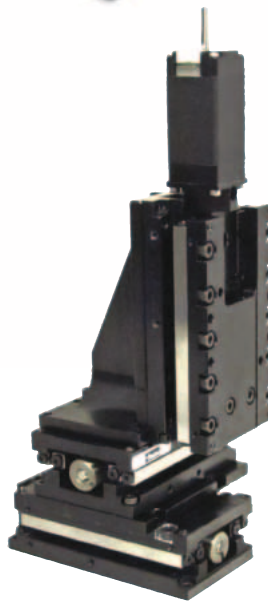

# MX - Miniature Positioners

Miniature Precision Axis

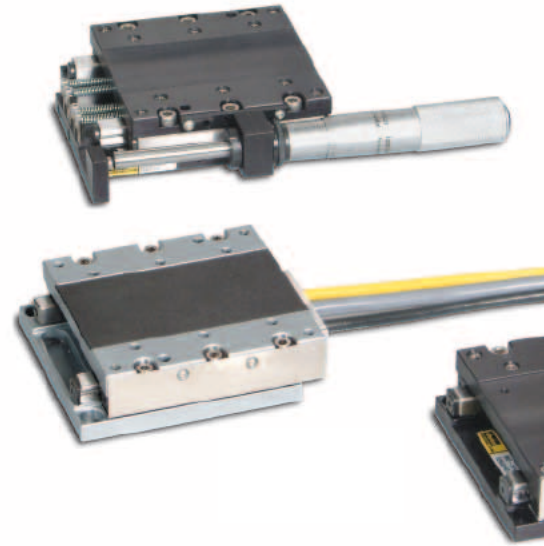
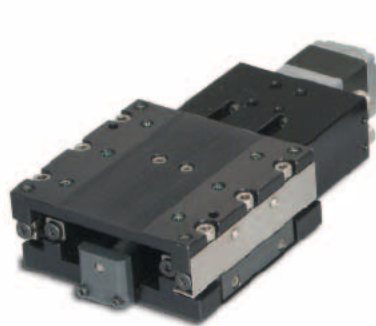

ENGINEERING YOUR SUCCESS.



**WARNING – USER RESPONSIBILITY**

**FAILURE OR IMPROPER SELECTION OR IMPROPER USE OF THE PRODUCTS DESCRIBED HEREIN OR RELATED ITEMS CAN CAUSE DEATH, PERSONAL INJURY AND PROPERTY DAMAGE.**

- This document and other information from Parker-Hannifin Corporation, its subsidiaries and authorized distributors provide product or system options for further investigation by users having technical expertise.
- The user, through its own analysis and testing, is solely responsible for making the final selection of the system and components and assuring that all performance, endurance, maintenance, safety and warning requirements of the application are met. The user must analyze all aspects of the application, follow applicable industry standards, and follow the information concerning the product in the current product catalog and in any other materials provided from Parker or its subsidiaries or authorized distributors.
- To the extent that Parker or its subsidiaries or authorized distributors provide component or system options based upon data or specifications provided by the user, the user is responsible for determining that such data and specifications are suitable and sufficient for all applications and reasonably foreseeable uses of the components or systems.

<b>Overview .....</b>	<b>5</b>
<b>MX45S - Ballscrew and Leadscrew Driven Stages .....</b>	<b>7</b>
Technical Characteristics .....	9
Diagram: Force - Speed .....	10
Performance Loading .....	10
Dimensions .....	11
<b>MX80S - Ballscrew and Leadscrew Driven Stages .....</b>	<b>13</b>
Technical Characteristics .....	15
Dimensions .....	16
<b>MX80L - Linear Motor Driven Stages .....</b>	<b>17</b>
Technical Characteristics .....	19
Diagram: Force - Speed .....	20
Diagram: Distance vs Time .....	20
Diagram: Life - Load (Normal Load) .....	20
Diagram: Velocity Ripple .....	20
Dimensions .....	21
<b>MX80M - Free Travel and Micrometer Driven Stages .....</b>	<b>22</b>
Technical Characteristics .....	22
Dimensions .....	23
<b>Options and Accessories .....</b>	<b>24</b>
Encoder Option .....	24
Home and Limit Sensor Option .....	24
Cable Option "Plug & Play" (MX80) .....	24
Motor Mounting Options .....	24
Environmental Protection Option (MX80) .....	25
Z-Axis Counterbalance Option (MX80L) .....	25
Pneumatic Package (MX80L) .....	25
System Orthogonality Option (MX80) .....	25
Mounting Bracket Kit Option (MX45S) .....	26
Z-Axis Bracket (MX80) .....	27
Digital Drives - Simple Configuration .....	28
<b>Order Code .....</b>	<b>29</b>
MX45S .....	29
MX80S .....	30
MX80L .....	31
MX80M .....	32

# Parker Hannifin

## The global leader in motion and control technologies

### A world class player on a local stage

#### Global Product Design

Parker Hannifin has more than 40 years experience in the design and manufacturing of drives, controls, motors and mechanical products. With dedicated global product development teams, Parker draws on industry-leading technological leadership and experience from engineering teams in Europe, North America and Asia.

#### Local Application Expertise

Parker has local engineering resources committed to adapting and applying our current products and technologies to best fit our customers' needs.

#### Manufacturing to Meet Our Customers' Needs

Parker is committed to meeting the increasing service demands that our customers require to succeed in the global industrial market. Parker's manufacturing teams seek continuous improvement through the implementation of lean manufacturing methods throughout the process. We measure ourselves on meeting our customers' expectations of quality and delivery, not just our own. In order to meet these expectations, Parker operates and continues to invest in our manufacturing facilities in Europe, North America and Asia.

#### Electromechanical Worldwide Manufacturing Locations

##### Europe

Littlehampton, United Kingdom  
Dijon, France  
Offenburg, Germany  
Filderstadt, Germany  
Milan, Italy

##### Asia

Wuxi, China  
Chennai, India

##### North America

Rohnert Park, California  
Irwin, Pennsylvania  
Charlotte, North Carolina  
New Ulm, Minnesota



Offenburg, Germany

#### Local Manufacturing and Support in Europe

Parker provides sales assistance and local technical support through a network of dedicated sales teams and authorized technical distributors throughout Europe.

For contact information, please refer to the Sales Offices on the back cover of this document or visit [www.parker.com](http://www.parker.com)



Milan, Italy



Littlehampton, UK

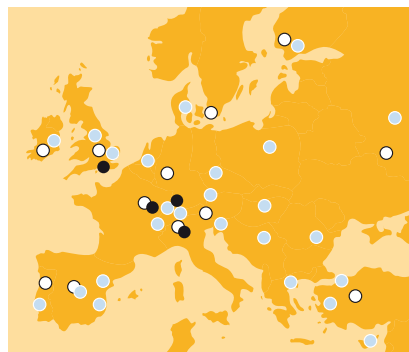

- Electromechanical Manufacturing
- Parker Sales Offices
- Distributors



Dijon, France

# Miniature Positioners - MX Series

## Overview

### Description

Life science applications are a good example of how miniaturization has driven the need for smaller and more efficient positioners. Parker's MX series miniature positioner, the smallest positioner in the industry, is loaded with high-performance features for both rapid travel and precise positioning of lighter loads in small work envelopes.

Designed for today's 24/7 production demands, the MX series has redefined "high-throughput automation" in the world of miniature positioners

### Typical areas of application

- Fiber optics
- Photonics
- Electronics and biomedical processes

### Features

- Low profile miniature size
- Different technologies available:
  - Ballscrew and leadscrew driven stages: MX45S, MX80S
  - Linear servo motor driven stages: MX80L
  - Free travel and micrometer driven stages: MX80M
- Cross roller bearing (zero cage creep option)
- Optional encoder
- Optional digital limit/home sensors
- Optional cleanroom and low ESD preparation
- Multi-axis platform

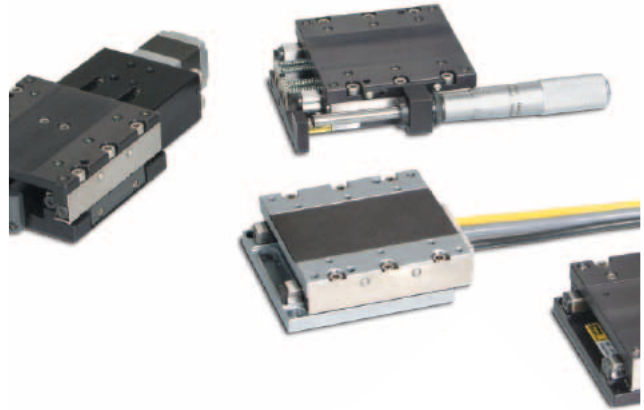

### Technical Characteristics - Overview

	Type: Miniature Positioners			
	MX45S	MX80S	MX80L	MX80M
<b>Technology</b>	screw driven		linear motor driven	manual driven
<b>Frame size height/width [mm]</b>	25x45 mm	35x80 mm	25x80 mm	25x80 mm
<b>Travel [mm]</b>	5, 15, 25	25, 50, 100, 150	25, 50, 100, 150, 200	25, 50
<b>Max. Speed [mm/s]</b>	20...2000			
<b>Nominal Load [kg]</b>	7	8	8	20
<b>Repeatability [µm]</b>	±1... ±8	±1.5... ±10	±0.4... ±10	-

### High performance in a small package

While the MX series is small in size, it is large on performance and reliability. All key components are "built-in" - residing within the body of the stage to provide a clean looking, reliable, unobstructed package. At the heart of the MX series is an innovative non-contact linear servo motor (patent pending). This MX series has been optimized for force, speed, and acceleration, to deliver outstanding performance and response.

A high-precision non-contact encoder provides submicrometer resolution, repeatability and accuracy. Precision ground cross roller bearing sets with a zero cage creep feature provide extremely smooth, precise linear translation. Digital Hall effect travel limit and home sensors are conveniently designed into the unit for easy adjustment over the entire travel of the stage. Although there are no moving cables, a meter of high-flex cabling is included and wired directly into the units. This high-flex cabling addresses cable flexing concerns associated with the second or third axis in multi-axis systems.

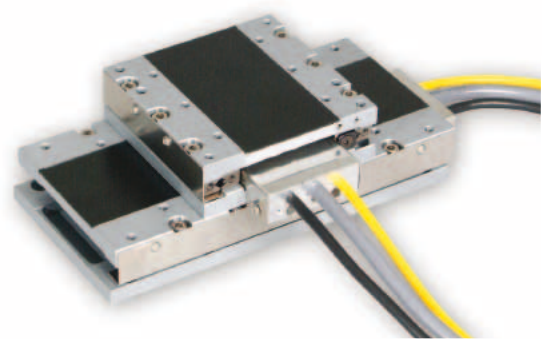

### Zero cage creep feature

High acceleration and smooth travel are both key features of the MX Series stage. The cross roller bearing system found in the MX series provides extremely smooth linear travel, and with an anti-cage creep design, operates very well in high acceleration applications. This design employs a rack and pinion feature within the bearing races to eliminate bearing creep. As a result, the MX series performs well, even at 49 m/s<sup>2</sup> acceleration.



### Tooling features

Innovative tooling features make mounting and alignment much quicker and easier.

- A hardened steel master reference surface is provided along the side of the stage to allow fixturing or other tooling elements to be precisely aligned with the actual travel path.
- Two dowel pin holes are provided on the carriage top and base for repeatable mounting of positioner or tooling.



## MX45S - Ballscrew and Leadscrew Driven Stages

### Description

Designed with anti-cage creep crossed roller bearings, the MX45S allows users to position up to 7 kg of normal load on the stage's three standard travel lengths (5, 15 & 25 mm).

The MX45S can be supplied with a high efficiency leadscrew or a high precision ground ballscrew, both of which are capable of producing 40 N of thrust and reaching linear velocities of 20 and 30 mm/s respectively.

The leadscrew drive employs a PTFE-coated screw with a preloaded nut to deliver extremely smooth and quiet linear motion. A choice of two leads allows the user to match the desired mix of velocity and resolution in order to best match the application's requirements.

The ballscrew drive is available in a 1 mm lead offering the user 3  $\mu\text{m}$  bi-directional repeatability and 24/7 operation (100 % duty cycle).

### Features

- **Ultra compact profile**  
(35 mm high x 80 mm wide)
- **Travels: 5, 15 and 25 mm**
- **Ballscrew or leadscrew drive options**
- **Anti-cage creep crossed roller bearings**
- **Axial thrust: up to 40 N**
- **Max velocity: 30 mm/s**
- **Stepper motor driven**
- **Digital limit/home sensor pack (option)**
- **Rotary or linear encoders (option)**
- **Multi-axis platforms**
- **Ideal for normal or cleanroom environments**



Leadscrew drive



Ballscrew drive

## Product Design

### Motor mount

NEMA 8 stepper motor mounts directly to stage housing

### Dowel pin holes

Ensure precise repeatable mounting

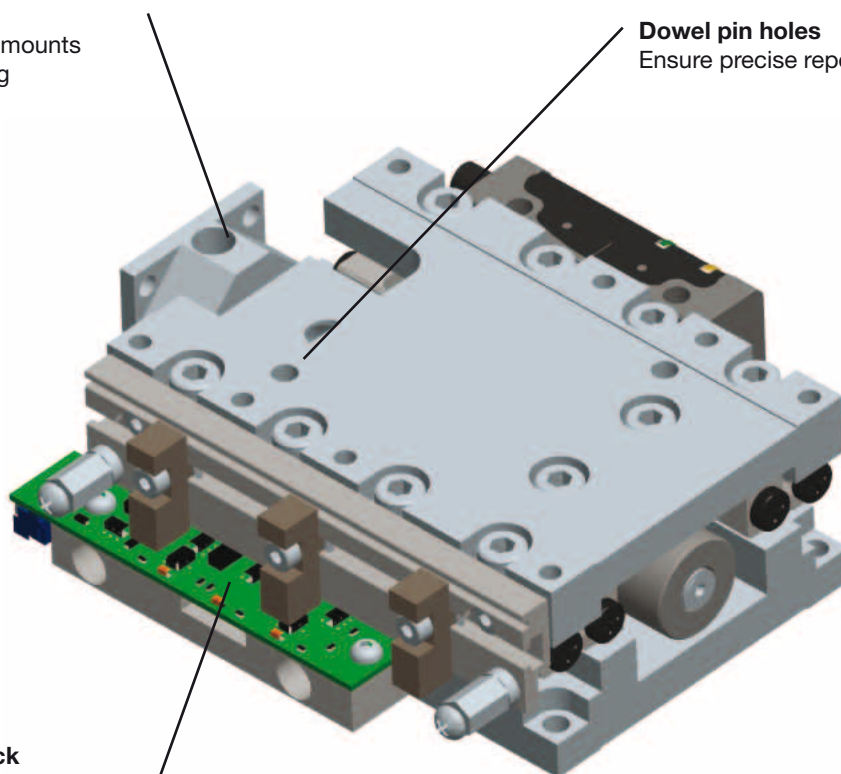

### Home/limit sensor pack

This optional field installable feature consists of three NPN or PNP switches, each of which is fully adjustable over the entire range of travel

### Optical linear encoders

Optional field installed feature is available in three standard resolutions (1.0  $\mu\text{m}$ , 0.1  $\mu\text{m}$  and sine output)

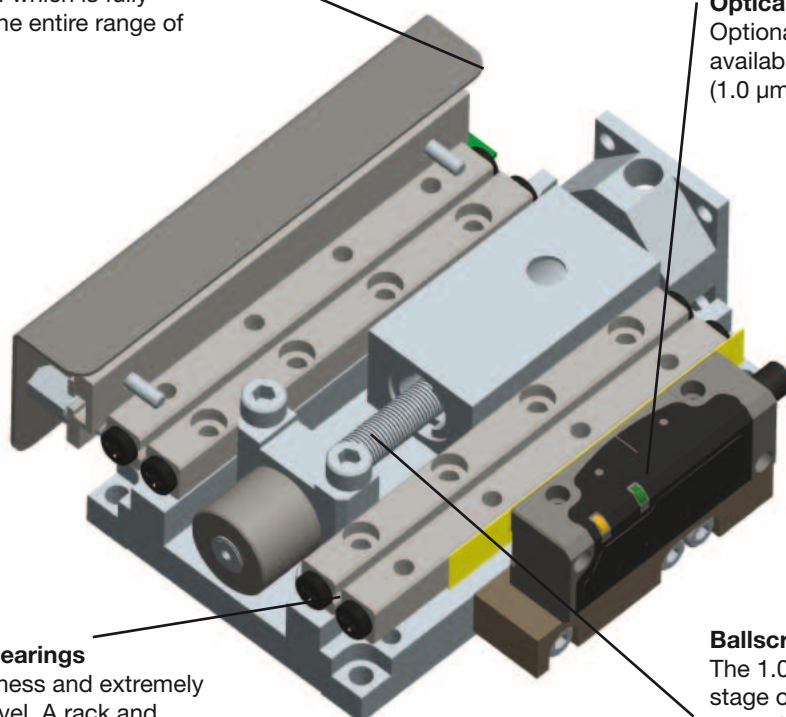

### Crossed roller bearings

provide high stiffness and extremely smooth linear travel. A rack and pinion anti-cage creep design within the bearing races prevents cage creep even at high acceleration, or with cantilevered loads

### Ballscrew or leadscrew drive

The 1.0 mm lead ballscrew driven stage offers high performance 24/7 operation with a thrust load capacity of 40 N and velocity to 30 mm/s. The leadscrew driven stages are available with 0.5 or 1.0 mm leads. The PTFE coated leadscrew provides extremely smooth linear travel at velocities of 20 mm/s



## Technical Characteristics

	Unit	MX45S Leadscrew Drive (Standard)			MX45S Ballscrew Drive (Precision)		
		T01	T02	T03	T01	T02	T03
<b>Travel</b> <sup>(1)</sup>	[mm]	5	15	25	5	15	25
<b>Nominal load</b>	[kg]	5	5	7	5	5	7
<b>Thrust Load</b>	[N]	40			40		
<b>Maximum velocity</b> <sup>(2)</sup>	0.5 mm lead	10			-		
	1.0 mm lead	20			30		
<b>Acceleration/deceleration</b>	[m/s <sup>2</sup> ]	20			20		
<b>Running torque</b>	[Nm]	0.011			0.011		
<b>Duty cycle</b>	[%]	50			100		
<b>Straightness &amp; flatness</b> <sup>(3)</sup>	[µm]	3	5	8	3	5	8
<b>Positional accuracy</b> <sup>(4)</sup>	with 2000 count rotary encoder	10	18	30	8	12	15
	with 1 or 0.1 µm linear encoder	6	10	12	6	10	12
<b>Bidirectional repeatability</b> <sup>(4), (5)</sup>	with 2000 count rotary encoder	±8			±3		
	with 1 µm linear encoder	±4			±2		
	with 0.1 µm linear encoder	±2			±1		
<b>Input inertia (without motor)</b>	0.5 mm lead	2.37	2.76	3.14	-	-	-
	1.0 mm lead	2.58	2.96	3.35	1.41	1.6	1.79
<b>Screw speed (max)</b>	[min <sup>-1</sup> ]	1200			1800		
<b>Screw diameter</b>	[mm]	4.7			4.0		
<b>Screw efficiency</b>	0.5 mm lead	30			-		
	1.0 mm lead	47			90		
<b>Bearing friction coefficient</b>	-	0.003			0.003		
<b>Unit weight</b>	Stage only	0.177	0.200	0.238	0.182	0.205	0.243
	Carriage Only	0.070	0.082	0.100	0.073	0.084	0.104
<b>Additional mass of motors&amp;options</b>	NEMA 8 stepper <sup>(6)</sup>	0.095			0.095		
	Linear encoder option <sup>(7)</sup>	0.016			0.016		
	Limit option sensor board <sup>(7)</sup>	0.005			0.005		

### Notes:

- (1) Travel is in the direction of the motor mount only.
- (2) See speed/force curve for performance with Parker motor.
- (3) Measured at the carriage center, 35 mm above the mounting surface @20 °C with no load. Unit bolted to granite surface, flat within 1 µm/300 mm.
- (4) Total accuracy and bi-directional repeatability over full travel (peak to peak) (with 0.5 or 1 mm leadscrew).
- (5) Repeatability valid with NEMA 8 stepper motor and encoder noted.
- (6) Includes rotary encoder (part of base)
- (7) Part of base

## Diagram: Force - Speed

**MX45S with Parker NEMA 8 stepper motor**

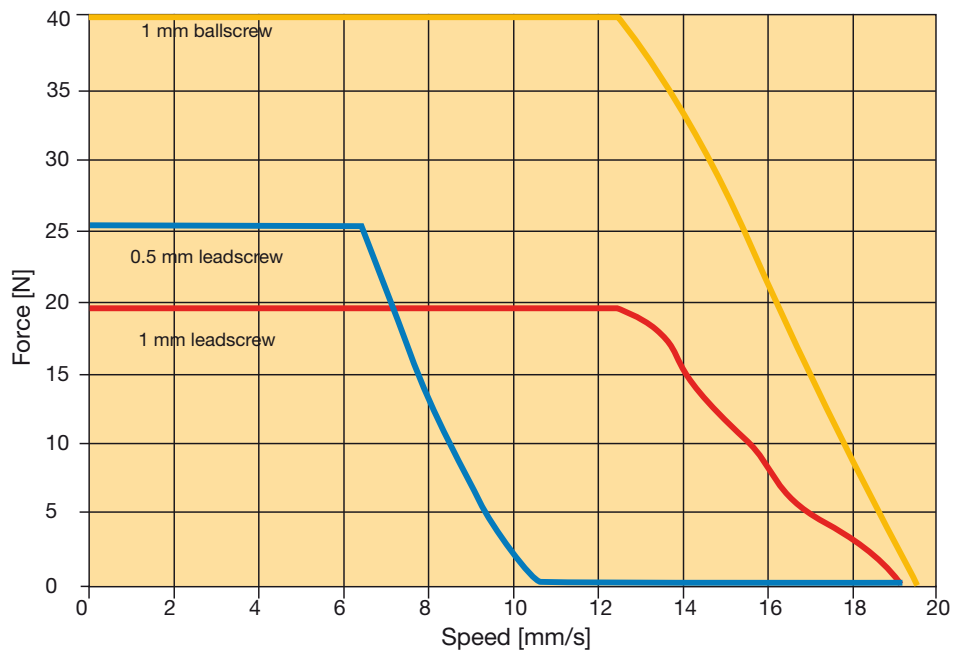

## Performance Loading

**Performance loading with 2540 km life time**

	Unit	
<b>Normal load capacity</b>		
5 mm travel	[kg]	5.0
15 mm travel		5.0
25 mm travel		7.0
<b>Pitch &amp; yaw moment loading</b>		
25 mm lever arm	[kg]	1.0
50 mm lever arm		0.6
75 mm lever arm		0.5
100 mm lever arm		0.4
<b>Roll moment loading</b>		
25 mm lever arm	[kg]	2.0
50 mm lever arm		1.2
75 mm lever arm		0.9
100 mm lever arm		0.7

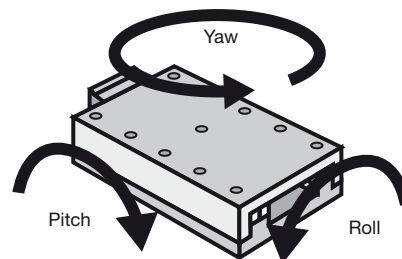

Dimensions [mm]

## Dimensions

### T01 - 5 mm travel

Mounting holes (4x top)  
threaded insert  
M3x0.5  
6.0 deep

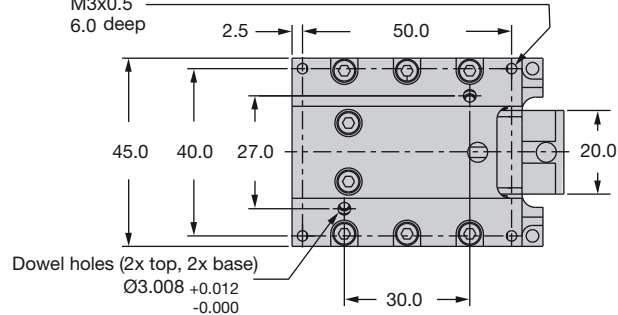

Top view

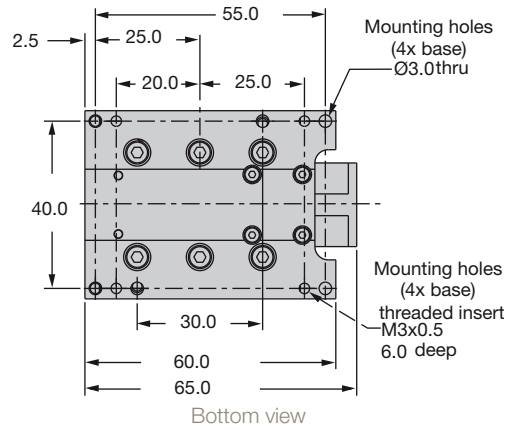

Bottom view

### T02 - 15 mm travel

Mounting holes (8x top)  
threaded insert  
M3x0.5  
6.0 deep

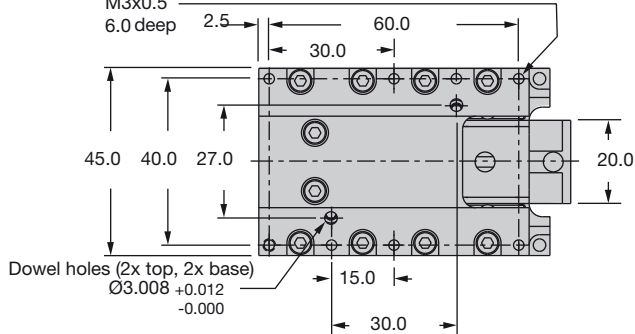

Top view

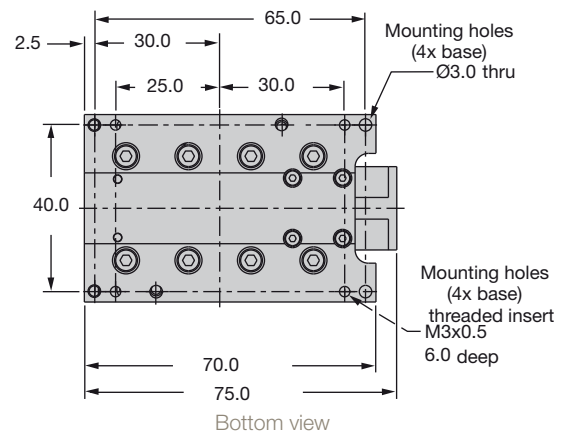

Bottom view

### T03 - 25 mm travel

Mounting holes (8x top)  
threaded insert  
M3x0.5  
6.0 deep

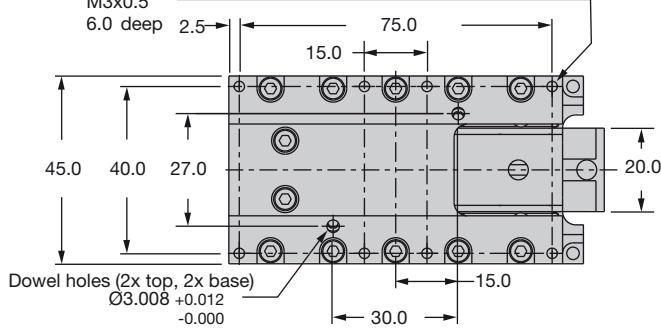

Top view

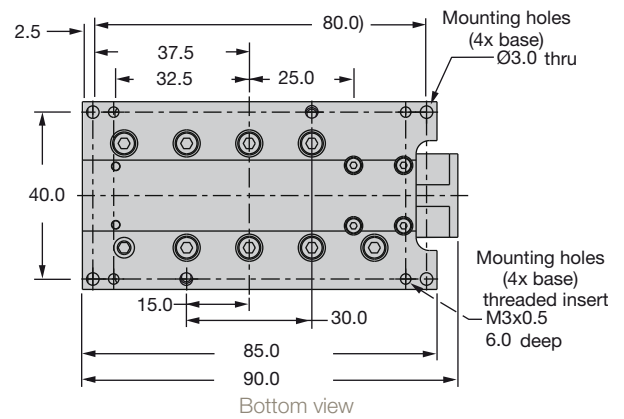

Bottom view

Note: For T01, T02 and T03, the carriage is shown at end of travel, available stroke towards motor mount only.

### T01, T02, T03

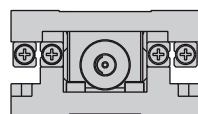

Bearing end view

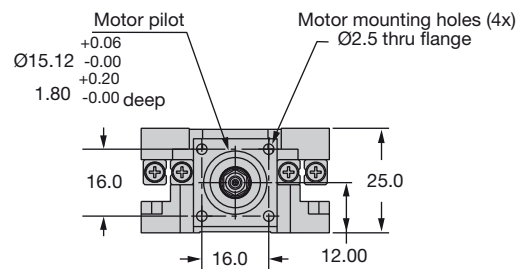

Motor side end view

**MX45S with option:**

Dimensions [mm]

**Encoder and home/limit sensor pack**

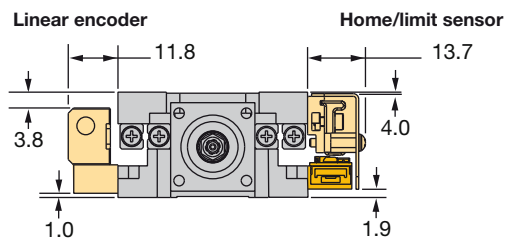

Motor end view

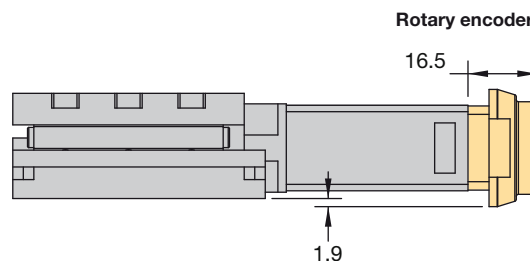

Side view

**MX45S with option:**

Dimensions [mm]

**Motor mounting**

**NEMA 8 motor mount**

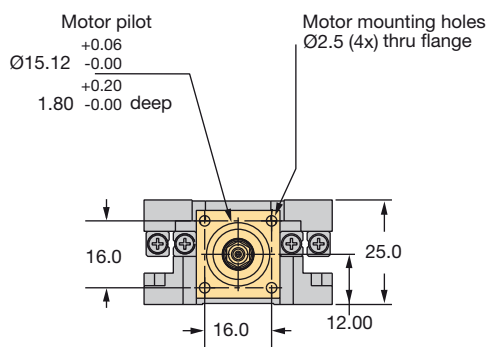
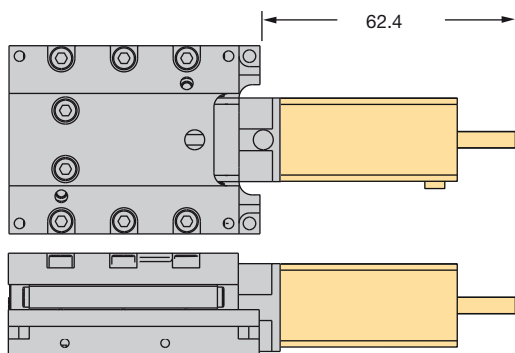

**NEMA 11 motor mount**

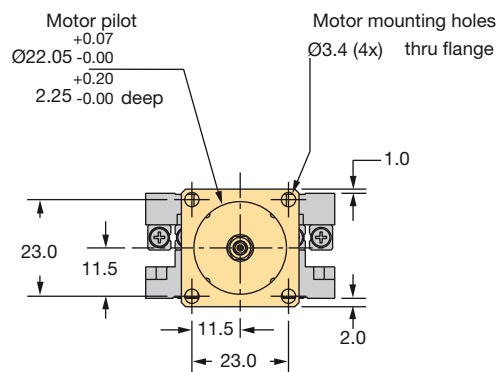
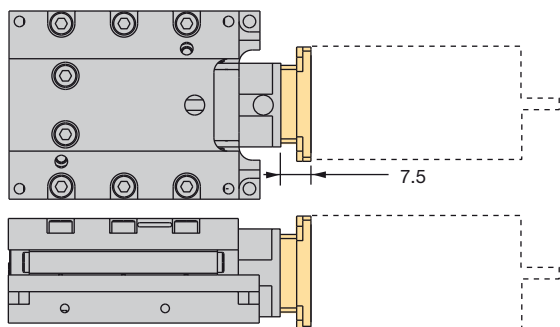

## MX80S - Ballscrew and Leadscrew Driven Stages

### Description

The MX80S miniature positioner is the screw driven member of Parker's MX80 series. Like its counterparts, the MX80L linear motor driven stage and MX80M manual stage, the MX80S is designed for applications requiring reliable linear positioning in space restricted applications. It is a complementary product that is the link between the high dynamic linear motor performance of the MX80L, and the manual precision of the MX80M. The MX80S can be supplied with a high-efficiency leadscrew drive capable of reaching 200 mm/s velocity, or a precision ground ballscrew drive offering axial thrust to 123 N.

The leadscrew drive employs a PTFE coated leadscrew with a preloaded nut to produce extremely smooth linear travel. A choice of three leads provides improved opportunity for matching desired velocity/resolution requirements.

The 2.0 mm lead ballscrew driven stage offers high performance 24/7 operation with a thrust load capacity of 123 N and velocity to 100 mm/s at 100 % duty cycle.

### Features

- Low profile miniature size (35 mm high x 80 mm wide)
- Travels: 25, 50, 100, 150 mm
- Multi-axis platform
- Ballscrew or leadscrew drive
- Axial thrust: up to 123 N
- Acceleration: 20 m/s<sup>2</sup>
- Cross roller bearing (zero cage creep option)
- Stepper or servo motor driven
- Digital limit/home system (option)
- Linear encoder (option)
- Cleanroom preparation (option)
- Low ESD option for electrically sensitive applications (option)



Leadscrew drive



Ballscrew drive

## Product Design

### Cross roller bearings

provide high stiffness and extremely smooth linear travel. A rack and pinion anti-cage creep design within the bearing races prevents cage creep even at high acceleration, or with cantilevered loads.

### Ballscrew drive or leadscrew drive

The 2.0 mm lead ballscrew driven stage offers high performance 24/7 operation with a thrust load capacity of 123 N and velocity to 100 mm/s at 100 % duty cycle. Leadscrew driven stages are available with 1, 2 or 10 mm leads. The PTFE coated leadscrew provides extremely smooth linear travel at velocities up to 200 mm/s.

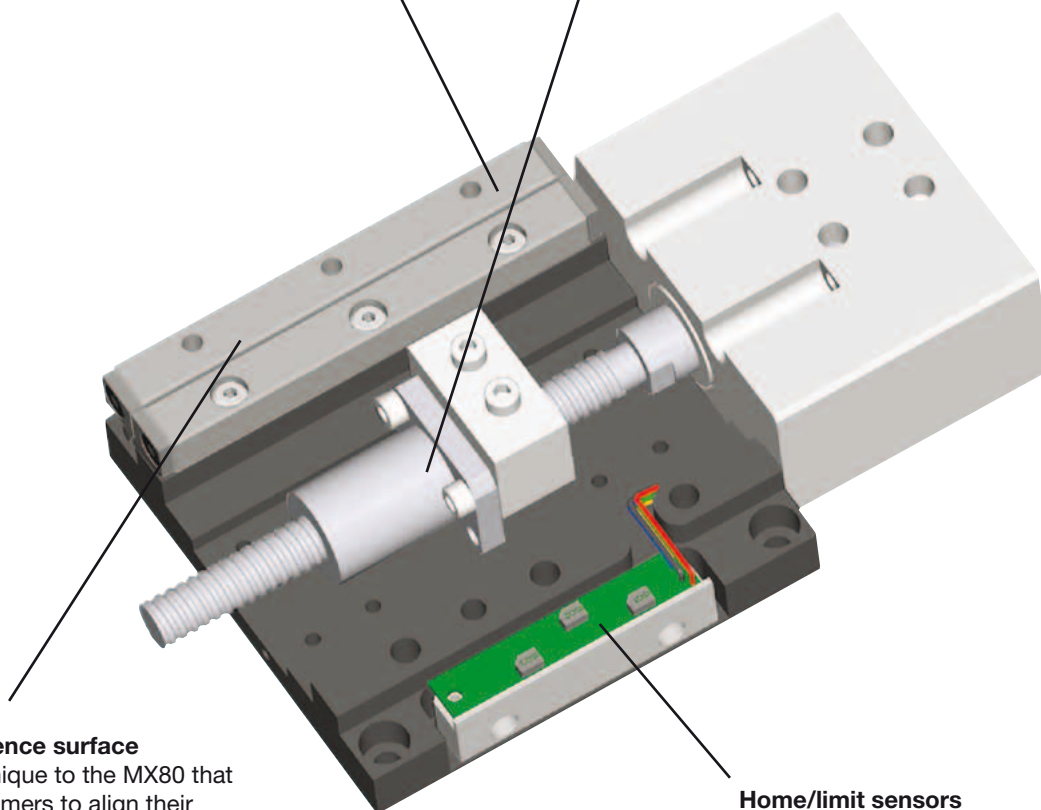

### Master reference surface

is a feature unique to the MX80 that enables customers to align their process to the actual travel path within micrometer.

### Home/limit sensors

are magnetic sensors completely housed within the body of the stage, and fully adjustable over the entire travel range.

## Technical Characteristics

		Unit	MX80S Leadscrew Drive (Standard)				MX80S Ballscrew Drive (Precision)			
			T01	T02	T03	T04	T01	T02	T03	T04
<b>Travel</b>		[mm]	25	50	100	150	25	50	100	150
<b>Nominal load</b>		[kg]	8	8	8	8	8	8	8	8
<b>Axial thrust force</b>		[N]	44	44	44	44	123	123	123	123
<b>Breakaway torque</b>		[Nm]	0.021	0.021	0.021	0.021	0.050	0.050	0.050	0.050
<b>Running torque</b>	1.0 mm lead	[Nm]	0.028	0.028	0.035	0.035	-	-	-	-
	2.0 mm lead		0.028	0.028	0.035	0.035	0.085	0.085	0.085	0.085
	10.0 mm lead		0.021	0.021	0.021	0.028	-	-	-	-
<b>Inertia (without motor and coupling)</b>	1.0 mm lead	[10 <sup>-7</sup> kgm <sup>2</sup> ]	1.47	1.47	2.42	3.06	-	-	-	-
	2.0 mm lead		1.62	1.62	2.68	3.42	4.19	4.19	6.08	7.68
	10.0 mm lead		6.34	6.34	11.30	14.90	-	-	-	-
<b>Screw speed (max)</b>		[min <sup>-1</sup> ]	1200	1200	1200	1200	3000	3000	3000	3000
<b>Screw diameter</b>		[mm]	6.35	6.35	6.35	6.35	8.00	8.00	8.00	8.00
<b>Maximum speed</b>	1.0 mm lead	[mm/s]	20	20	20	20	-	-	-	-
	2.0 mm lead		40	40	40	40	100	100	100	100
	10.0 mm lead		200	200	200	200	-	-	-	-
<b>Bidirectional repeatability*</b>	1.0 mm lead	[μm]	±5.0	±5.0	±5.0	±5.0	-	-	-	-
	2.0 mm lead		±5.0	±5.0	±5.0	±5.0	±1.5	±1.5	±1.5	±1.5
	10.0 mm lead		±10.0	±10.0	±10.0	±10.0	-	-	-	-
<b>Positional accuracy*</b>	1.0 mm lead	[μm]	30	45	75	100	-	-	-	-
	2.0 mm lead		30	45	75	100	10	15	18	20
	10.0 mm lead		35	50	80	105	-	-	-	-
<b>Straightness &amp; flatness</b>		[μm]	8	12	16	20	8	12	16	20
<b>Screw efficiency</b>	1.0 mm lead	[%]	40	40	40	40	-	-	-	-
	2.0 mm lead		59	59	59	59	90	90	90	90
	10.0 mm lead		78	78	78	78	-	-	-	-
<b>Bearing friction coefficient</b>		-	0.003	0.003	0.003	0.003	0.003	0.003	0.003	0.003
<b>Duty cycle</b>		[%]	50	50	50	50	100	100	100	100
<b>Unit weight</b>	Table only with 2-stack stepper	[kg]	0.597	0.597	1.003	1.268	0.694	0.694	1.114	1.392
			0.748	0.748	1.154	1.419	0.845	0.845	1.265	1.513
<b>Carriage weight (unloaded)</b>		[kg]	0.194	0.194	0.353	0.471	0.291	0.291	0.464	0.595

\* **Notes: MX80SS (leadscrew drive)**

- (1) Measured at the carriage center, 35 mm above the mounting surface @ 20 °C with no load. Unit bolted to granite surface, flat to within 1 μm/300 mm.
- (2) Total accuracy and bi-directional repeatability over full travel (peak to peak).

\* **Notes: MX80S (ballscrew drive)**

- (1) Measured at the carriage center, 35 mm above the mounting surface @ 20 °C with no load. Unit bolted to granite surface, flat to within 1 μm/300 mm.
- (2) Total accuracy and bi-directional repeatability over full travel (peak to peak).
- (3) Repeatability valid with M21 servo motor.

## Dimensions

Dimensions [mm]

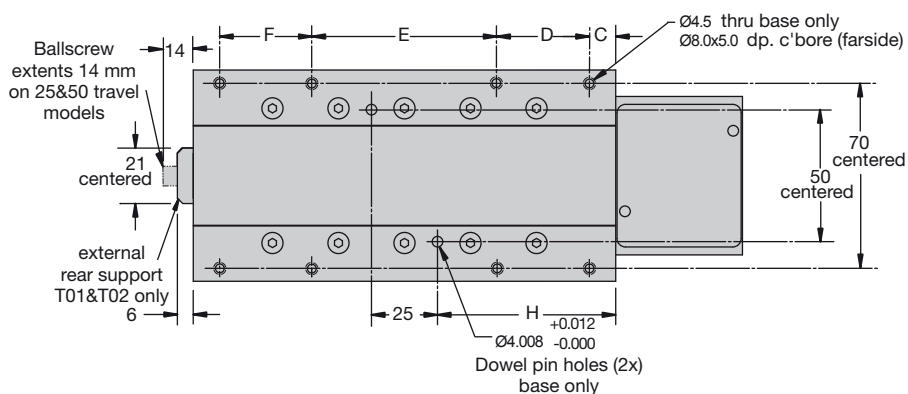
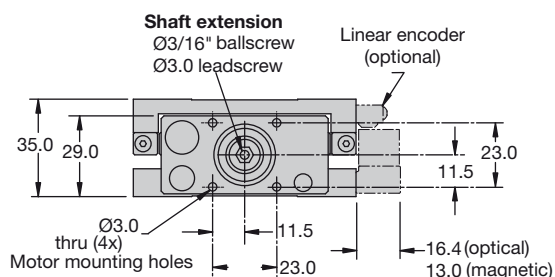
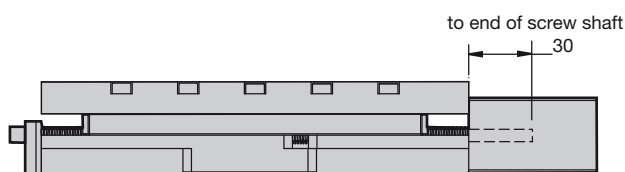
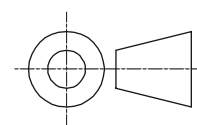
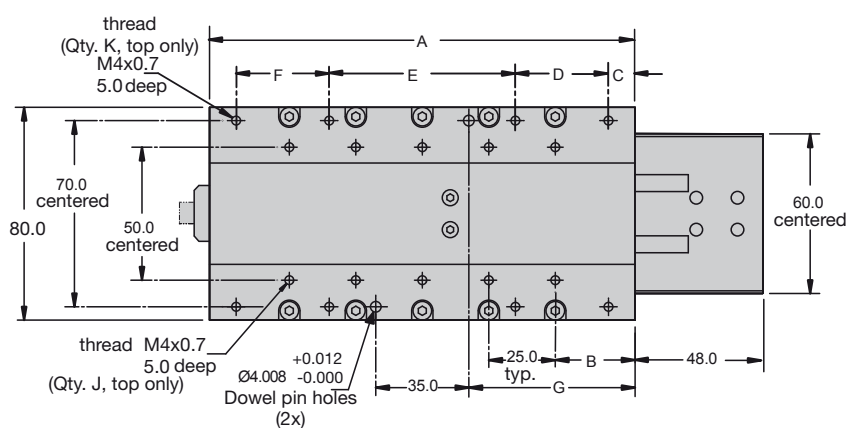

Travel	A	B	C	D	E	F	G	H	J	K
	[mm]									
25	80	15	5	70	—	—	22.5	27.5	6	4
50	80	15	5	70	—	—	22.5	27.5	6	4
100	160	30	10	35	70	35	62.5	67.5	10	8
150	210	30	5	65	70	65	87.5	92.5	14	8

## Mounting

### Stepper motor

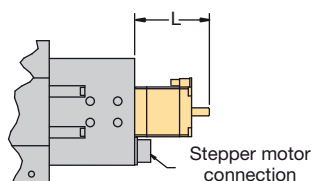

### Servo motor

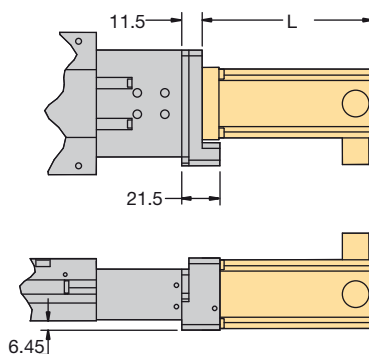

Model	Stack	NEMA	L [mm]
Stepper motor	1	11	42.0
	2		50.0
	3		61.5
Servo motor	1	16	83.6



## MX80L - Linear Motor Driven Stages

### Description

Parker's MX80L miniature stage, the smallest linear servomotor driven positioner in the industry, is loaded with high-performance features for both rapid linear translation and precise positioning of lighter loads in small work envelopes.

### Features

- Low profile miniature size (25 mm high x 80 mm wide)
- Short settling times
- Submicrometer precision
- High velocity 2 m/s
- Multi-axis platform
- Six linear encoder resolutions: (0.01...5.0  $\mu\text{m}$ )
- Travels: 25, 50, 100, 150 and 200 mm
- Cross roller bearing (zero cage creep design)
- Precision or standard grade
- Cleanroom and low ESD option
- Fully adjustable home and limit sensors
- Dowel holes for repeatable payload mounting
- Master reference surface to travel path
- Plug-in intelligent drive
- Pneumatic Z-axis counterbalance
- No moving cables

### MX80L Standard Series

Standard grade units offer a lower cost alternative for applications requiring high throughput performance with less demanding positioning requirements. They are constructed of high alloy aluminum, providing a lighter weight design which can accelerate to 49 m/s<sup>2</sup>.

- Acceleration 50 m/s<sup>2</sup>
- Repeatability to  $\pm 0.8 \mu\text{m}$
- Straightness 6  $\mu\text{m}$
- Light weight aluminum body
- Low luster black anodize finish

### MX80L Precision Series

Precision grade models are designed for high-performance applications requiring the highest degree of positioning accuracy. They offer a steel body design with precisely ground mounting surfaces & bearing ways. They include higher resolution linear encoders, and are slope corrected, laser tested and certified for optimum precision.

- Acceleration 40 m/s<sup>2</sup>
- Repeatability to  $\pm 0.4 \mu\text{m}$
- Straightness 4  $\mu\text{m}$
- Steel body construction
- Precision ground mounting and bearing surfaces
- Electroless nickel protective finish

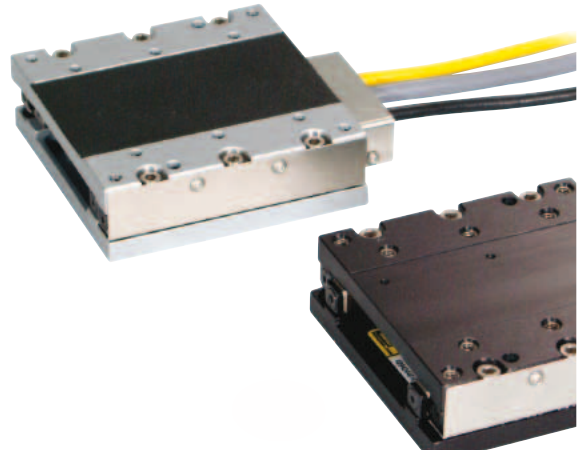

MX80LS



MX80LP

## Product Design

### Cross roller bearings

provide high stiffness and extremely smooth linear travel. A rack and pinion anti-cage creep design within the bearing races prevents cage creep even at high acceleration, or with cantilevered loads.

### Linear servo motors

features a patent pending ironcore design that provides high thrust density for linear acceleration to 50 m/s<sup>2</sup> and velocities to 2 m/s. The non-contact design offers long life and clean operation.

### Optical linear encoders

are available in six standard resolutions (10 nm, 20 nm, 0.1  $\mu$ m, 0.5  $\mu$ m, 1.0  $\mu$ m, 5.0 mm) and is fully integrated within the body of the stage. The non-contact design offers long life and clean operation.

### Master reference surface

is a feature unique to the MX80 that enables customers to align their process to the actual travel path within micrometer.

### Home/limit sensors

are magnetic sensors completely housed within the body of the stage, and fully adjustable over the entire travel range.

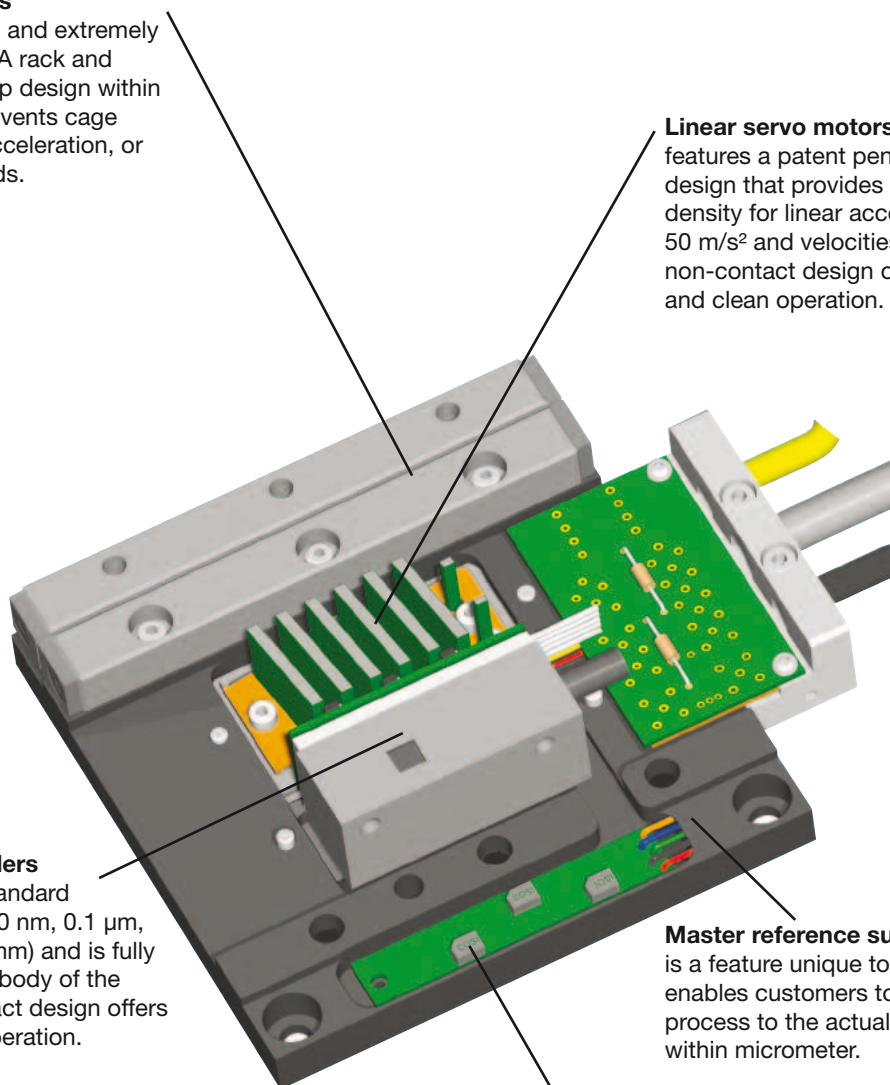

## Technical Characteristics

		Unit	MX80L Precision Grade				MX80L Standard Grade				
			T01	T02	T03	T04	T01	T02	T03	T04	T05
<b>Travel</b>		[mm]	25	50	100	150	25	50	100	150	200
<b>Continuous force</b>		[N]	4	4	8	8	4	4	8	8	8
<b>Peak force</b>		[N]	12	12	24	24	12	12	24	24	24
<b>Continuous current</b>		[A <sub>rms</sub> ]	0.8	0.8	1.6	1.6	0.8	0.8	1.6	1.6	1.6
<b>Peak current**</b>		[A]	2.4	2.4	4.8	4.8	2.4	2.4	4.8	4.8	4.8
<b>Force constant</b>		[N/A <sub>rms</sub> ]	5.51	5.51	5.51	5.51	5.51	5.51	5.51	5.51	5.51
<b>Nominal load</b>		[kg]	8	8	8	8	8	8	8	8	8
<b>Max. speed</b> Encoder resolution:	5.0 µm	[mm/s]	1100	1500	2000	2000	1100	1500	2000	2000	2000
	1.0 µm		1100	1500	2000	2000	1100	1500	2000	2000	2000
	0.5 µm		1100	1500	1500	1500	1100	1500	1500	1500	1500
	0.1 µm		300	300	300	300	300	300	300	300	300
	0.02 µm		60	60	60	60	60	60	60	60	60
	0.01 µm		30	30	30	30	30	30	30	30	30
	Sine Cosine		1100	1500	2000	2000	1100	1500	2000	2000	2000
<b>Max. acceleration</b>		[m/s <sup>2</sup> ]	40	40	40	30	50	50	50	40	30
<b>Bidirectional repeatability*</b> Encoder resolution:	5.0 µm	[µm]	±10.0	±10.0	±10.0	±10.0	±10.0	±10.0	±10.0	±10.0	±10.0
	1.0 µm		±2.0	±2.0	±2.0	±2.0	±2.0	±2.0	±2.0	±2.0	±2.0
	0.5 µm		±1.0	±1.0	±1.0	±1.0	±1.0	±1.0	±1.0	±1.0	±1.0
	0.1 µm		±0.5	±0.5	±0.5	±0.5	±0.5	±0.5	±0.5	±0.5	±0.7
	0.02 µm		±0.4	±0.4	±0.4	±0.4	±0.4	±0.4	±0.4	±0.4	±0.5
	0.01 µm		±0.4	±0.4	±0.4	±0.4	±0.4	±0.4	±0.4	±0.4	±0.5
	Sine Cosine		±0.4	±0.4	±0.4	±0.4	±0.4	±0.4	±0.4	±0.4	±0.5
<b>Positional accuracy*</b> Encoder resolution:	5.0 µm	[µm]	13	14	15	15	25	30	35	35	35
	1.0 µm		5	6	7	7	15	20	25	25	25
	0.5 µm		4	5	6	6	12	15	20	20	20
	0.1 µm		3	4	5	5	12	15	20	20	20
	0.02 µm		3	4	5	5	12	15	20	20	20
	0.01 µm		3	4	5	5	12	15	20	20	20
	Sine Cosine		3	4	5	5	12	15	20	20	20
<b>Straightness &amp; flatness</b>		[µm]	4	4	5	6	6	6	10	12	14
<b>Duty cycle</b>		[%]	100	100	100	100	100	100	100	100	100
<b>Unit weight</b>		[kg]	0.590	0.590	1.027	1.345	0.475	0.475	0.875	1.125	1.370
<b>Carriage weight (unloaded)</b>		[kg]	0.282	0.282	0.509	0.676	0.213	0.213	0.405	0.537	0.695

\*\* based on a winding temperature of up to 60 °C for a period of  
T01, T02: 1.2 s  
T03, T04, T05: 5 s

\* **Notes MX80L (Precision):**  
(1) Measured at the carriage center, 35 mm above the mounting surface @ 20 °C with no load. Unit bolted to granite surface, flat to within 1 µm/300 mm.  
(2) Total accuracy and bi-directional repeatability over full travel (peak to peak).  
(3) Precision grade with slope correction value. Consult factory if better accuracy is required.

\* **Notes MX80L (Standard):**  
(1) Total accuracy and bi-directional repeatability over full travel (peak to peak).

Diagram: Force - Speed

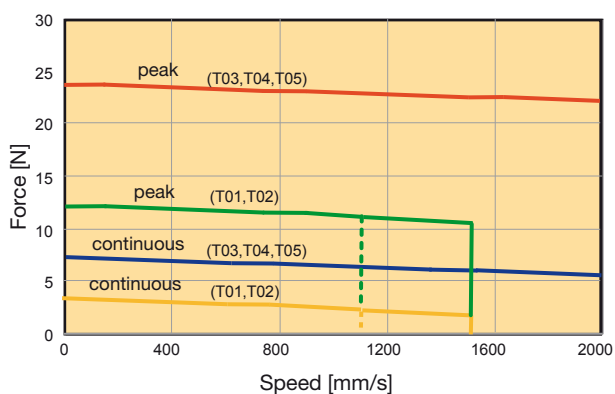

Note:  
T01 (25 mm travel) is limited to a maximum speed of 1100 mm/s.  
T02 (50 mm) is limited to 1500 mm (due to limited travel).

Diagram: Life - Load (Normal Load)

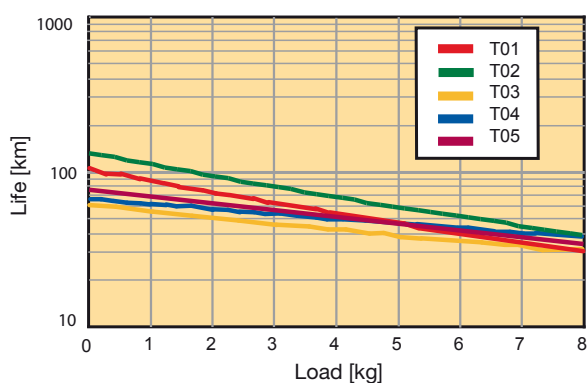
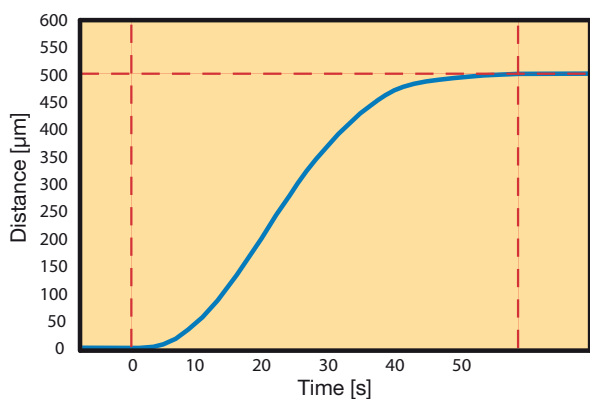
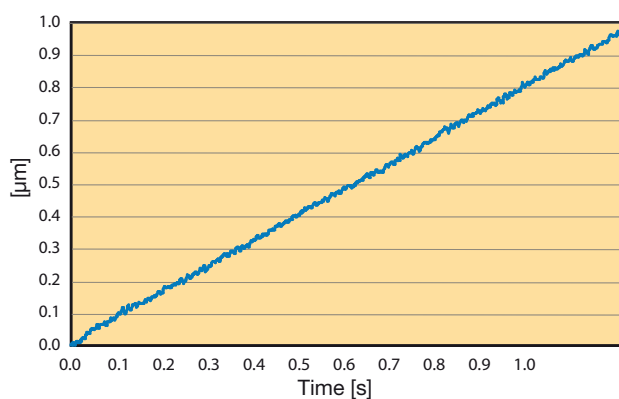

Diagram: Distance vs Time



Note:  
1 kg payload, 500 µm move: Move and settle to within 1 µm in 47 ms.

Diagram: Velocity Ripple



Note:  
Tests were performed using a model MX80LT04D13E8 with a 20 nm linear encoder.

Dimensions [mm]

## Dimensions

### T01, T02, T03, T04

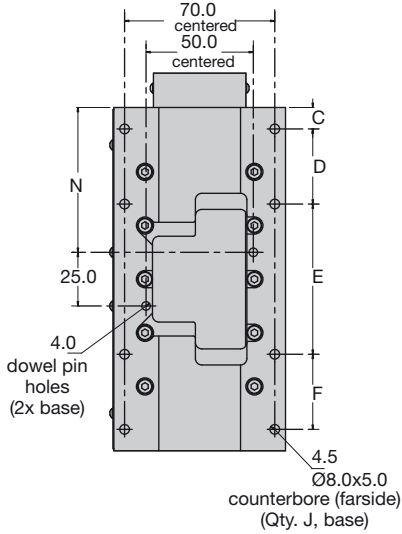
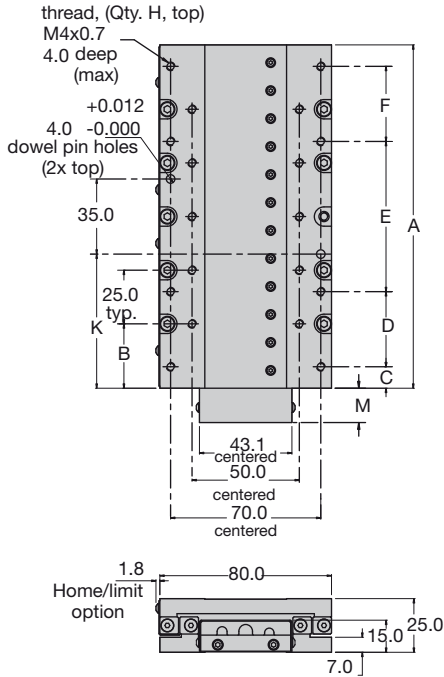

### T05

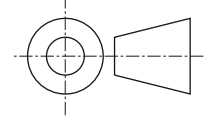
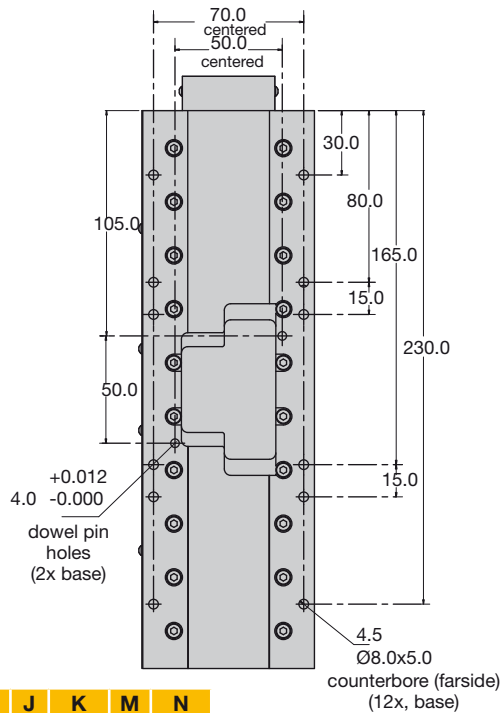
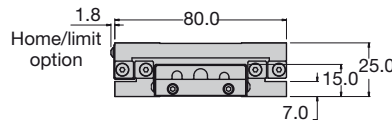
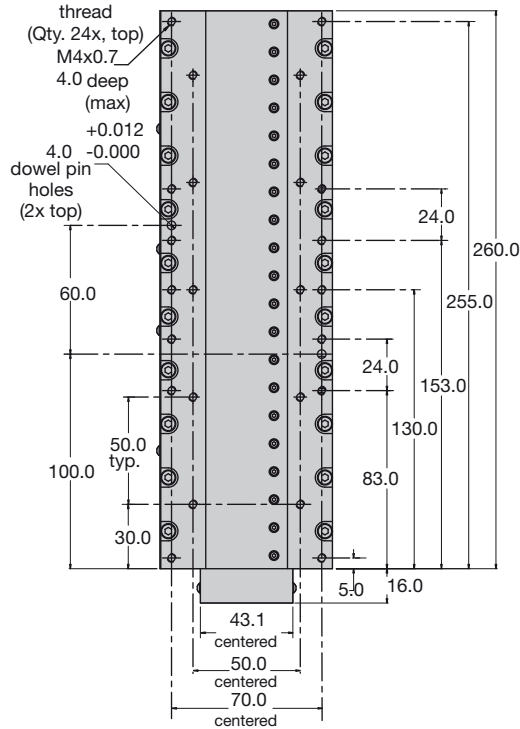

### Z-axis

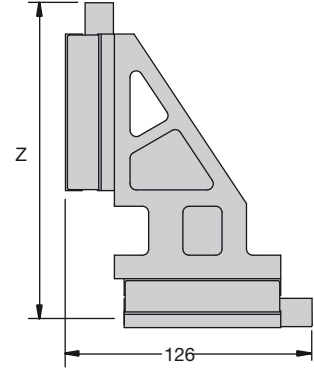

Travel	Z [mm]
25	166
50	166
100	251
150	326
200	not possible

### Pneumatic vertical axis counter balance

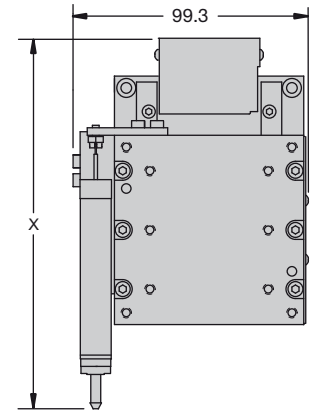

Travel	X [mm]
25	156.6
50	156.6
100	230.6
150	310.6
200	not possible

Travel	A	B	C	D	E	F	H	J	K	M	N
	[mm]										
25	80	15	5	70	—	—	10	4	22.5	22	27.5
50	80	15	5	70	—	—	10	4	22.5	22	27.5
100	160	30	10	35	70	35	18	8	62.5	16	67.5
150	210	30	5	65	70	65	22	8	87.5	16	92.5

## MX80M - Free Travel and Micrometer Driven Stages

### Description

The MX80M stages are offered as free travel or micrometer driven units with 25 mm or 50 mm travel. They include innovative tooling features to make mounting and precision alignment quicker and easier. A hardened steel master reference surface is provided along the side of the stage to allow fixturing or other tooling elements to be precisely aligned with the actual travel path. Dowel pin holes are provided on the carriage top for repeatable mounting or tooling. Also available are custom features such as a steel body design, vacuum prepped units, and anti cage creep bearings for high dynamic applications up to 150 mm travel.

### Features

- Precision cross roller bearings
- Clean room preparation (option)
- Low ESD coating (option)
- Dowel holes in top & base
- Interchangeable mounting with motorized MX80 models
- Positive position lock

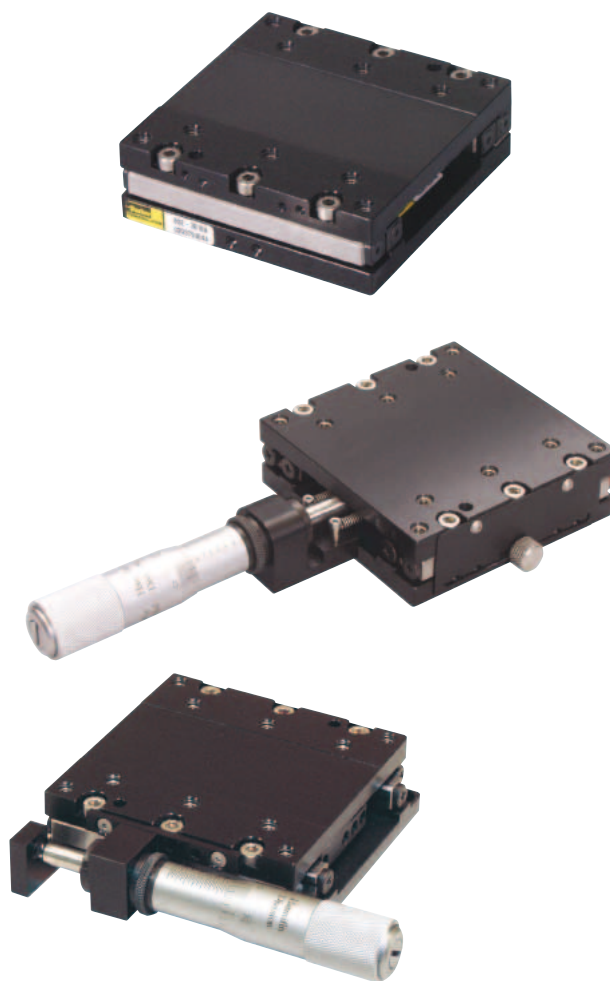

### Technical Characteristics

	Unit	MX80M free travel		MX80M micrometer driven	
		T01	T02	T01	T02
<b>Travel</b>	[mm]	25	50	25	50
<b>Nominal load</b>	[kg]	20	20	20	20
<b>Axial force <sup>(1)</sup></b>					
F <sub>a</sub>	[N]	-	-	44.1	44.1
F <sub>b</sub>		-	-	5.9	9.8
<b>Straight line accuracy</b> (per 25 mm travel)	[μm]	2	2	2	2
<b>Micrometer resolution</b>					
0.001 in	-	-	-	Yes	Yes
0.01 mm		-	-	Yes	Yes
<b>Digital micrometer</b>					
0.00005 in	-	-	-	Yes	Yes
0.001 mm		-	-	Yes	Yes

<sup>(1)</sup> F<sub>a</sub> (Force acting against micrometer)  
 F<sub>b</sub> (Force acting against spring)

## Dimensions

Dimensions [mm]

### Free travel (with position lock)

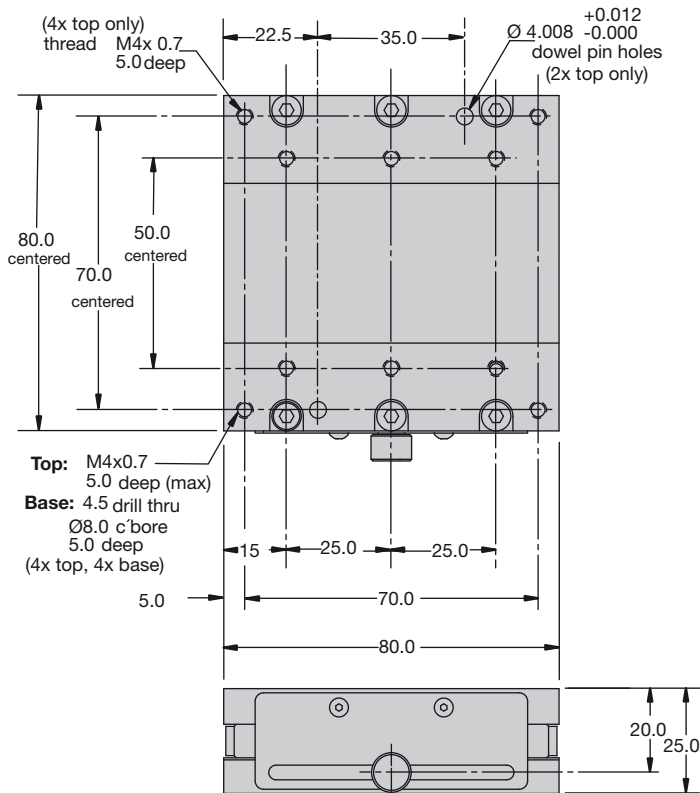
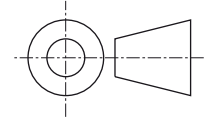

### Standard micrometer (center drive shown)

### Digital micrometer (side drive shown)

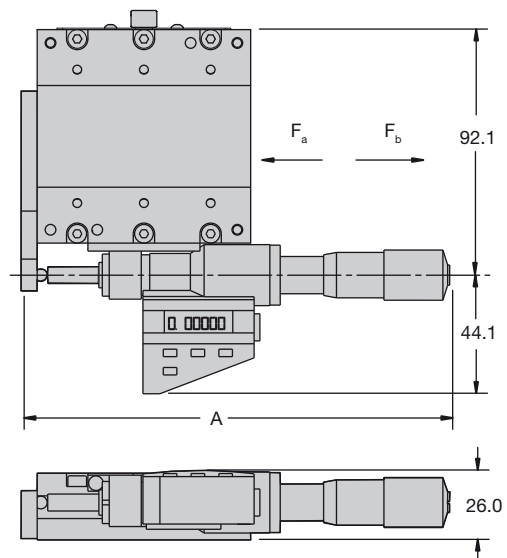
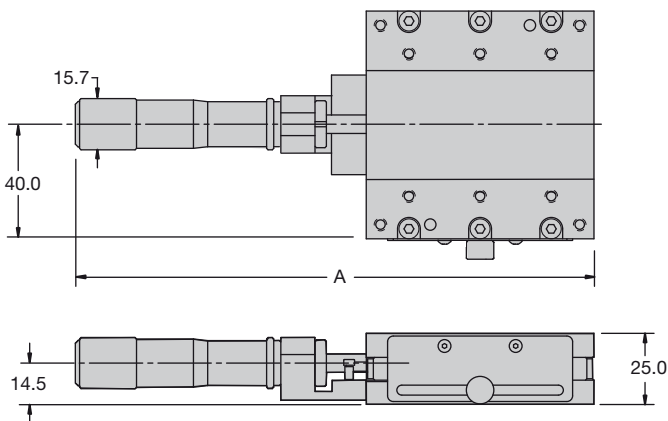

Drive orientation	Travel [mm]	A [mm]
Center	25	182.2
	50	231.4
Side	25	117.2
	50	167.4

Drive orientation	Travel [mm]	A [mm]
Center	25	225.6
	50	273.5
Side	25	160.6
	50	209.5

## Options and Accessories

### Encoder Option

Order codes: E..

#### Linear Encoder

##### MX80

A non-contact linear optical encoder provides a quadrature output and offers resolution ranging from 10 nm to 5 µm further more there is a sine output available.

On the MX80L, the encoder is internal to the stage body. There is no increase to the footprint of the unit and no additional external cabling is required.

##### MX45

On the MX45S, the encoder is mounted externally to the stage body, an addition which can be added later if application requirements change.

#### Rotary Encoder

When using stepper motors, positional feedback is readily available with the optional rotary encoder. 400- and 500-line rotary encoders provide position verification and position maintenance.

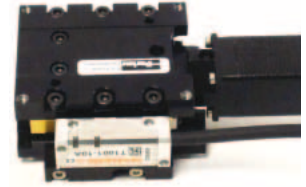

MX45S with linear encoder

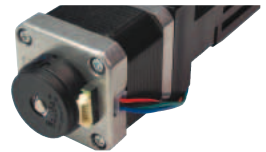

Rotary encoder

### Home and Limit Sensor Option

Order codes: H., L..

The MX45S features an innovative, compact, fully adjustable and field-installed home/limit sensor pack. The output format is either NPN or PNP and is available as either N.O. or N.C. The sensor pack is powered with 5 to 24 VDC and is capable of sinking or sourcing up to 50 mA per switch.

On the MX80 series the magnetic home and limit sensors are completely housed within the body of the stage. An innovative design adds functionality without sacrificing geometry. Sensor triggers can be easily adjusted over the travel. The output format is an open collector type capable of sinking up to 50 mA, and be set as N.O. or N.C.

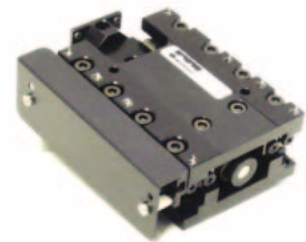

MX45S with home/limit sensor pack

### Cable Option "Plug & Play" (MX80)

Order codes: CM..

"User convenience" is high on the list of cable features found in the MX series. The high-flex cabling and connectors are reliable, durable and offer easy hook-up for „plug and run“ installation.

- High-flex cables
- Plug-in compatibility with ViX drive
- CE compliant connectors and shielding
- Color coded jackets and labeling
- Connectors simplify installation



### Motor Mounting Options

Order codes: N., M..

The MX series can be ordered with motor or prepared for motor mounting. Motor availability depends on the ordered MX drive technology.



## Environmental Protection Option (MX80)

Both precision and standard grade units have a hard coat protective finish. The precision units have a hard coat (Rc 78) satin chrome finish, and the standard units have a low luster black anodized finish.

### Cleanroom Option

**Order codes: R..**

Both precision and standard grade products can be prepared for cleanroom compatibility. Preparation involves material changes, element modification and cleanroom compatible lubricants. MX80L and MX80S stages with this option are class 10 cleanroom compatible. When applying an XY or XYZ combination in a cleanroom environment, moving wires need to be considered - please consult a Parker application engineer.



### Low ESD Finish

**Order codes: R..**

An optional low ESD electroless nickel or Armoloy coating is offered for improved electrical conductivity, providing a low resistance to ground path for electric discharge.



## Z-Axis Counterbalance Option (MX80L)

**Order codes: X..**

A pneumatic Z-axis counterbalance is offered to prevent a sudden load drop if power to the motor is interrupted. A controlled vertical force is applied to the stage top to negate the effect of gravity and achieve equilibrium. A precisely regulated clean air supply of 0 to 413.7 kPa is required for operation.

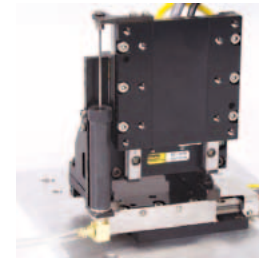

## Pneumatic Package (MX80L)

This accessory is offered for use with the pneumatic counterbalance option. It consists of a pre-filter, a pressure regulator, a coalescing filter, and a precision regulator to precisely regulate air pressure and remove oil, water or debris down to 3 µm.

**Part number: 002-2236-01**



## System Orthogonality Option (MX80)

**Order codes: S..**

In any multi-axis positioning system, the perpendicular alignment of the axes must be clearly specified. „Degree of orthogonality“ defines the perpendicular alignment of one axis to another. The MX80 offers two choices for orthogonality. As standard, perpendicularity is held to within 60 arc seconds. For more exacting applications the MX80 can be optioned for 15 arc seconds orthogonality.

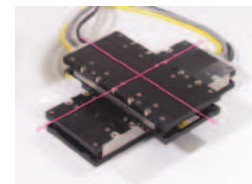

## Mounting Bracket Kit Option (MX45S)

Order codes: K..

### MX45S to MX45S (Mounting Bracket Kits)

To build multi-axis MX45S systems, mounting bracket kits are available to build the two and three-axis configurations.

Note that only Y-axis travel is a selection criteria; X- and Z-axis travel is not.

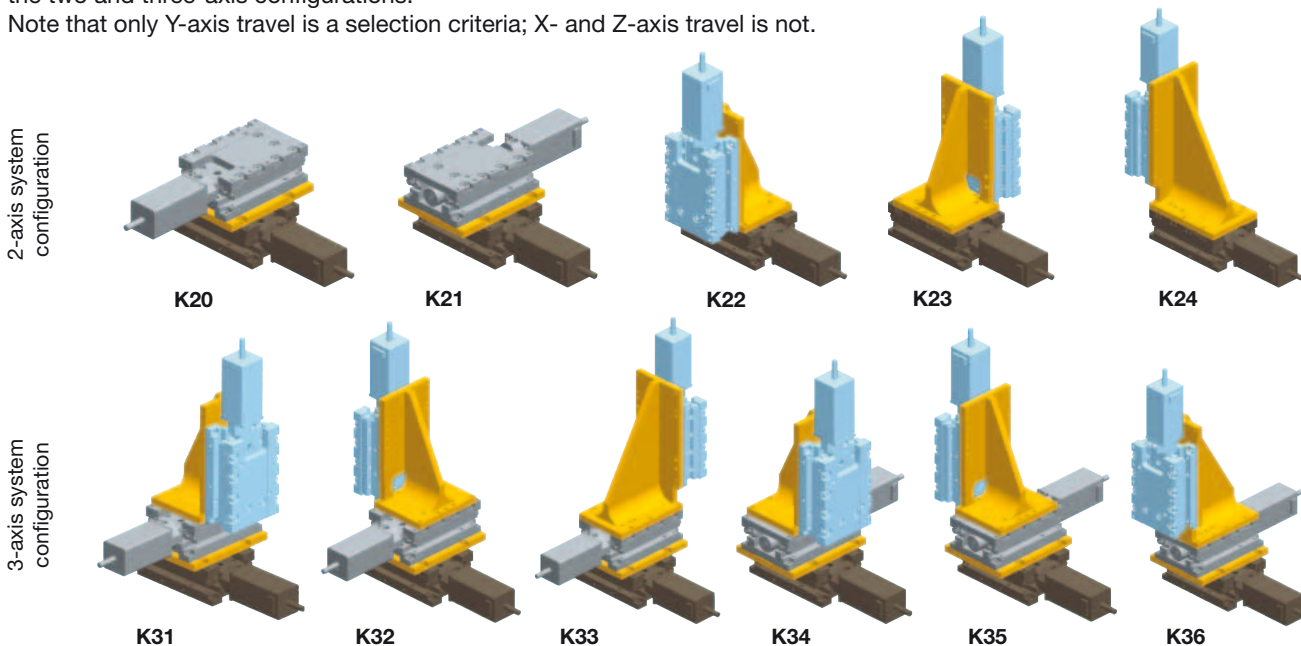

### Multi-axis bracket kits

	Bracket Kit	Part number		
		T01 *	T02 *	T03 *
2-axis system configuration	K20	002-2956-200	002-2956-201	002-2956-202
	K21	002-2956-200	002-2956-201	002-2956-202
	K22	-	002-2956-220	-
	K23	-	002-2956-220	-
	K24	-	002-2956-240	-
3-axis system configuration	K31	002-2956-310	002-2956-311	002-2956-312
	K32	002-2956-310	002-2956-311	002-2956-312
	K33	002-2956-330	002-2956-331	002-2956-332
	K34	002-2956-310	002-2956-311	002-2956-312
	K35	002-2956-310	002-2956-311	002-2956-312
	K36	002-2956-330	002-2956-331	002-2956-332

\* T01, T02 and T03 designates Y axis travel only

### Z-axis bracket\*

Bracket Kit	T01, T02, T03		
	Height (1) [mm]	Width (2) [mm]	Depth (3) [mm]
K22, K23	85	45	55
K24, K33, K36	104	45	55
K31, K32, K34, K35	85	55	45

\* not compatible with N11 motor mounts

### X-Y axis bracket

Bracket Kit	T01	T02	T03
	Depth (3) [mm]		
K20, K21, K31, K32, K33, K34, K35, K36	60	70	85

### Z-axis bracket

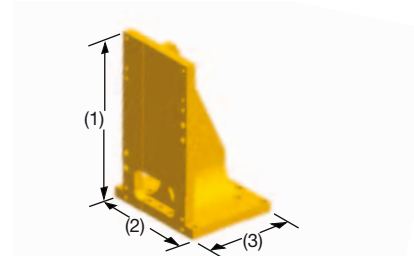

### X-Y axis transition plate bracket

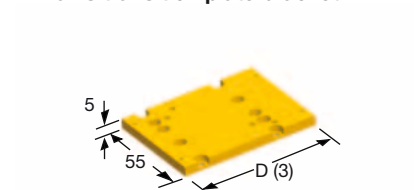

### MX45S to MX80 (Mounting Brackets)

MX45S positioners can also be used as a Y- or Z-axis in conjunction with MX80 positioners.

Kit	Configuration	Part number	Height	Width	Depth
			[mm]		
X-Y	MX45ST01 - MX80	002-2958-01	5	80	80
	MX45ST02 - MX80	002-2958-02	5	80	80
	MX45ST03 - MX80	002-2958-03	5	80	92.5
X-Z*	MX45S (all) - MX80	002-2958-04	87.5	80	80

\* not compatible with N11 motor mounts

### Z-Axis Bracket (MX80)

Lightweight aluminium Z-brackets are available for easy construction of vertical axis combinations (MX80).

**Part number: Standard model**

25, 50 mm: 002-2238-01

100, 150 mm: 002-2240-01

**Part number: ESD-protection**

5 & 50 mm: 002-2239-01

100 & 150 mm: 002-2241-01

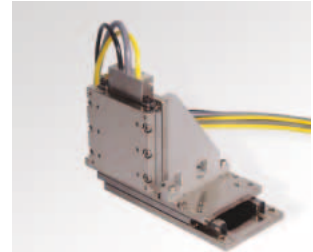

## Digital Drives - Simple Configuration

Tuning is easy and intuitive for users and is available via a variety of methods. The motor and loading information must be known by the drive to determine the baseline tuning gains. These are simple parameter entries the user can complete with the help of several Parker tools. Seamless integration of drives and controls ensures performance matched functionality of the completed motion system.

### ViX - Intelligent Servo & Microstepping Drives/Controller

#### Order separately

The ViX servo and microstepping drives are the perfect drive solution to be paired with the MX80 series. These drives use advanced field oriented digital control technology to enhance dynamic performance and improve efficiency. In addition to servo and microstepping versions, the ViX family is offered with different levels of control.

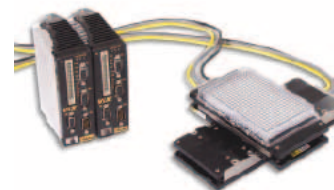

MX80 with ViX

### VXLPSU - Power Supply Module

#### Order separately

The Parker power supply offers a convenient way of powering a ViX servo drive. The continuous rated output is 240 W at 230 VAC or 960 W at 400 VAC input and supplies the 80 V main DC rail and operates directly from all AC supplies between 90 V and 264 V. No external EMC filters are required unless the motor leads are exceptionally long (e.g. greater than 30 m).

**Part number: VXLPSU240 and VXLPSU960**

### Compax3 - Intelligent Servo Drives/Controllers

#### Order separately

With a Compax3 drive, a transformer must be used. Parker provides a suitable transformer.

**Part number: TO255**



MX80 with Compax3

# Order Code

## MX45S

	1	2	3	4	5	6	7	8	9
Order example	<b>MX45S</b>	<b>T01</b>	<b>S</b>	<b>K</b>	<b>D1</b>	<b>N00</b>	<b>E000</b>	<b>L0</b>	<b>K00S</b>

### 1 Series

**MX45S** Miniature Linear Positioner

### 2 Travel - mm

<b>T01</b>	5
<b>T02</b>	15
<b>T03</b>	25

### 3 Grade

<b>S</b>	Standard (leadscrew drive)
<b>P</b>	Precision (ballscrew drive)

### 4 Bearing type\*

<b>K</b>	Anti-creep system (ACS) crossed roller bearings
----------	---

### 5 Drive type

<b>D1</b>	0.5 mm leadscrew <sup>(1)</sup>
<b>D2</b>	1 mm leadscrew <sup>(1)</sup>
<b>D3</b>	1 mm ballscrew <sup>(2)</sup>

<sup>(1)</sup> With standard grade only.  
<sup>(2)</sup> With precision grade only.

### 6 Motor mounting option

<b>N00</b>	No motor no motor flange, no coupler
<b>N08</b>	No motor, NEMA 8 motor flange, & coupler
<b>N11</b>	No motor, NEMA 11 motor flange, & coupler <sup>(1)</sup>
<b>M10</b>	NEMA 8 stepper motor mounted <sup>(2)</sup>
<b>M11</b>	NEMA 8 stepper motor mounted <sup>(3)</sup>

<sup>(1)</sup> Not available with T03 travel option on K20 and K22 X-Y axis bracket kits or Z-axis bracket kits (K22 thru K36).  
<sup>(2)</sup> With 1 m cable, flying leads.  
<sup>(3)</sup> With 1 m cable with P2 drive connector.

### 7 Encoder option\*

<b>E000</b>	None
<b>ER10</b>	Rotary Encoder, 400-line <sup>(1)</sup> , flying leads
<b>ER11</b>	Rotary Encoder, 400-line <sup>(1)</sup> , ViX connector
<b>ER12</b>	Rotary Encoder, 400-line <sup>(1)</sup> , ACR connector
<b>ER13</b>	Rotary Encoder, 400-line <sup>(1)</sup> , 6K connector
<b>ER20</b>	Rotary Encoder, 500-line <sup>(1)</sup> , flying leads
<b>ER21</b>	Rotary Encoder, 500-line <sup>(1)</sup> , ViX connector
<b>ER22</b>	Rotary Encoder, 500-line <sup>(1)</sup> , ACR connector
<b>ER23</b>	Rotary Encoder, 500-line <sup>(1)</sup> , 6K connector
<b>EL20</b>	Linear Encoder <sup>(2)</sup> 1 µm resolution
<b>EL30</b>	Linear Encoder <sup>(2)</sup> 0.5 µm resolution
<b>EL40</b>	Linear Encoder <sup>(2)</sup> 0.1 µm resolution
<b>EL50</b>	Linear Encoder <sup>(2)</sup> 5 µm resolution
<b>EL70</b>	Linear Encoder <sup>(2)</sup> sine output

\* Consult factory for other options.  
<sup>(1)</sup> Encoder equipped with 1 m high-flex cable  
<sup>(2)</sup> Encoder equipped with 1 m high-flex cable, 15-pin D-sub connector; Z-channel in center position

### 8 Home/limit sensor option\*

<b>L0</b>	None
<b>L2</b>	N.O. home/N.C. limit, NPN, 1 m cable flying leads
<b>L4</b>	N.O. home/N.C. limit, PNP, 1 m cable flying leads

\* NC=Normally Closed; NO=Normally Open.  
Home switch not available with T01; use one of the limits as home for T01.

### 9 Multi-axis kit option

<b>K00S</b>	Single-axis
<b>K20X</b>	X-Y System Multi-Axis Mounting Bracket-Kit (9 o'clock) - X-axis designator
<b>K20Y</b>	X-Y System Multi-Axis Mounting Bracket-Kit (9 o'clock) - Y-axis designator
<b>K21X</b>	X-Y System Multi-Axis Mounting Bracket-Kit (3 o'clock) - X-axis designator
<b>K21Y</b>	X-Y System Multi-Axis Mounting Bracket-Kit (3 o'clock) - Y-axis designator
<b>K22X</b>	X-Z System Multi-Axis Mounting Bracket-Kit (9 o'clock) - X-axis designator
<b>K22Z</b>	X-Z System Multi-Axis Mounting Bracket-Kit (9 o'clock) - Z-axis designator
<b>K23X</b>	X-Z System Multi-Axis Mounting Bracket-Kit (3 o'clock) - X-axis designator
<b>K23Z</b>	X-Z System Multi-Axis Mounting Bracket-Kit (3 o'clock) - Z-axis designator
<b>K24X</b>	X-Z System Multi-Axis Mounting Bracket-Kit (12 o'clock) - X-axis designator
<b>K24Z</b>	X-Z System Multi-Axis Mounting Bracket-Kit (12 o'clock) - Z-axis designator
<b>K31X</b>	X-Y-Z System Multi-Axis Mounting Bracket-Kit (9/6 o'clock) - X-axis designator
<b>K31Y</b>	X-Y-Z System Multi-Axis Mounting Bracket-Kit (9/6 o'clock) - Y-axis designator
<b>K31Z</b>	X-Y-Z System Multi-Axis Mounting Bracket-Kit (9/6 o'clock) - Z-axis designator
<b>K32X</b>	X-Y-Z System Multi-Axis Mounting Bracket-Kit (9/12 o'clock) - X-axis designator
<b>K32Y</b>	X-Y-Z System Multi-Axis Mounting Bracket-Kit (9/12 o'clock) - Y-axis designator
<b>K32Z</b>	X-Y-Z System Multi-Axis Mounting Bracket-Kit (9/12 o'clock) - Z-axis designator
<b>K33X</b>	X-Y-Z System Multi-Axis Mounting Bracket-Kit (9/3 o'clock) - X-axis designator
<b>K33Y</b>	X-Y-Z System Multi-Axis Mounting Bracket-Kit (9/3 o'clock) - Y-axis designator
<b>K33Z</b>	X-Y-Z System Multi-Axis Mounting Bracket-Kit (9/3 o'clock) - Z-axis designator
<b>K34X</b>	X-Y-Z System Multi-Axis Mounting Bracket-Kit (3/6 o'clock) - X-axis designator
<b>K34Y</b>	X-Y-Z System Multi-Axis Mounting Bracket-Kit (3/6 o'clock) - Y-axis designator
<b>K34Z</b>	X-Y-Z System Multi-Axis Mounting Bracket-Kit (3/6 o'clock) - Z-axis designator
<b>K35X</b>	X-Y-Z System Multi-Axis Mounting Bracket-Kit (3/12 o'clock) - X-axis designator
<b>K35Y</b>	X-Y-Z System Multi-Axis Mounting Bracket-Kit (3/12 o'clock) - Y-axis designator
<b>K35Z</b>	X-Y-Z System Multi-Axis Mounting Bracket-Kit (3/12 o'clock) - Z-axis designator
<b>K36X</b>	X-Y-Z System Multi-Axis Mounting Bracket-Kit (3/9 o'clock) - X-axis designator
<b>K36Y</b>	X-Y-Z System Multi-Axis Mounting Bracket-Kit (3/9 o'clock) - Y-axis designator
<b>K36Z</b>	X-Y-Z System Multi-Axis Mounting Bracket-Kit (3/9 o'clock) - Z-axis designator

## MX80S

	1	2	3	4	5	6	7	8	9	10	11	12	13	14	15
Order example	<b>MX80S</b>	<b>T04</b>	<b>M</b>	<b>P</b>	<b>K</b>	<b>D4</b>	<b>M1</b>	<b>H3L3</b>	<b>CM08</b>	<b>E3</b>	<b>Z1</b>	<b>R1</b>	<b>A1</b>	<b>S1</b>	<b>X1</b>

### 1 Series

**MX80S**

### 2 Travel - mm

**T01** 25

**T02** 50

**T03** 100

**T04** 150

### 3 Mounting

**M** Metric

### 4 Grade

**S** Standard (leadscrew drive)

**P** Precision\* (ballscrew drive)

\* Must order digital option E3 or E4

### 5 Bearing type

**J** Standard cross rollers

**K** ACS cross roller

### 6 Drive type

**D1** 1 mm leadscrew <sup>(1)</sup>

**D2** 2 mm leadscrew <sup>(1)</sup>

**D3** 10 mm leadscrew <sup>(1),(3)</sup>

**D6** 2 mm ballscrew <sup>(2),(3)</sup>

<sup>(1)</sup> With standard grade only.

<sup>(2)</sup> With precision grade only.

<sup>(3)</sup> Not available with 1- or 2-stack stepper motor.

### 7 Motor mounting option

**M0** No motor, no flange, no coupling

**M1** No motor, no coupling  
NEMA 16 flange

**M14** LV111 (stepper motor, 1 stack, NEMA 11)

**M15** LV112 (stepper motor, 2 stack, NEMA 11)

**M16** LV113 (stepper motor, 3 stack, NEMA 11)

**M21** Servo motor (1 stack, NEMA 16)

### 8 Home/limit sensor option

**H1L1** None

**H2L2** N.C. home/N.C. limit

**H2L3** N.C. home/N.O. limit

**H3L2** N.O. home/N.C. limit

**H3L3** N.O. home/N.O. limit

### 9 Cable option (high-flex)

**CM01** None

**CM02** 1 m Highflex Limits/Home Sensor Only  
Cable (flying leads)

**CM03** 3 m Highflex Limits/Home Sensor Only  
Cable (flying leads)

**CM04** 1 m Highflex Limits/Home Sensor Only  
Cable with ViX Connector

**CM05** 3 m Highflex Limits/Home Sensor Only  
Cable with ViX Connector

**CM06** 1 m Highflex Stepper Motor Cables with  
ViX Connector

**CM07** 3 m Highflex Stepper Motor Cables with  
ViX Connector

**CM08** 1 m Highflex Stepper Motor Cables with  
ViX Connector, no Limits/Home

**CM09** 3 m Highflex Stepper Motor Cables with  
ViX Connector, no Limits/Home

**CM15** 3 m Highflex Servo Motor Cables with ViX  
Connector

**CM17** 3 m Highflex Servo Motor Cables with ViX  
Connector, no Limits/Home

### 10 Encoder option

**E1** None

**E2** 1.0 µm resolution

**E3** 0.5 µm resolution

**E4** 0.1 µm resolution

**E5** 5.0 µm resolution

**E7** Sine output

### 11 Z channel location

**Z1** None

**Z3** Center position

### 12 Finish

**R1** Standard finish (black anodized)

**R2** Cleanroom preparation

**R10** Low ESD finish

**R20** Low ESD finish & cleanroom preparation

### 13 Digital drive

**A1** None

### 14 Orthogonality

**S1** None (single-axis)

**S2** X-axis base unit (cables @ 12 o'clock)

**S3** Y-axis 60 arcsec (cables @ 3 o'clock)

**S4** Y-axis 60 arcsec (cables @ 9 o'clock)

**S5** Y-axis 15 arcsec (cables @ 3 o'clock)

**S6** Y-axis 15 arcsec (cables @ 9 o'clock)

### 15 Required designator

**X1**

## MX80L

	1	2	3	4	5	6	7	8	9	10	11	12	13	14
Order example	<b>MX80L</b>	<b>T02</b>	<b>M</b>	<b>P</b>	<b>D11</b>	<b>H3</b>	<b>L2</b>	<b>CM08</b>	<b>Z3</b>	<b>E7</b>	<b>R1</b>	<b>A1</b>	<b>X1</b>	<b>S1</b>

<b>1 Series</b>	<b>MX80L</b>
<b>2 Travel - mm</b>	
T01	25
T02	50
T03	100
T04	150
T05	200
<b>3 Mounting</b>	
M	Metric
<b>4 Grade</b>	
S	Standard
P	Precision*
* not available with T05 travel	
<b>5 Drive type</b>	
D1	None - free travel/idler
D11	4 pole (25 & 50 mm travel only)
D13	8 pole (100, 150 & 200 mm travel only)
<b>6 Home sensor</b>	
H1	None - for drive type D1
H2	N.C., sinking
H3	N.O., sinking
<b>7 Limit sensor</b>	
L1	None - for Drive type D1
L2	N.C., sinking
L3	N.O., sinking
<b>8 Cable option (high-flex)</b>	
CM03	None - for Drive type D1
CM04	1 m Highflex Cables with ViX Connector
CM05	3 m Highflex Cables with ViX Connector
CM06	1 m Highflex Cables with ViX Connector, no Limits/Home
CM07	3 m Highflex Cables with ViX Connector, no Limits/Home
CM08	1 m Highflex Cables with Compax3 Connector
CM09	3 m Highflex Cables with Compax3 Connector*

\*Please note:

With a Compax3 drive, a transformer (e.g. TO255) must be used, i.e. the intermediate voltage must not exceed 80 VDC.

<b>9 Z channel location</b>	
Z1	None
Z3	Center position
<b>10 Encoder option</b>	
E1	None
E2	1.0 µm resolution
E3	0.5 µm resolution
E4	0.1 µm resolution
E7	Sine Cosine V <sub>ss</sub> (for C3F12)
E8	0.02 µm resolution (20 nm)
E9	0.01 µm resolution (10 nm)
<b>11 Finish</b>	
R1	Standard finish (black anodized)
R2	Cleanroom preparation
R10	Low ESD finish
R20	Low ESD finish & cleanroom preparation
<b>12 Digital drive</b>	
A1	None
<b>13 Additional option</b>	
X1	None
X2	Z-axis pneumatic counter balance*
* not available with T05 travel	
<b>14 Orthogonality</b>	
S1	None (single-axis)
S2	X-axis base unit (cables @ 12 o'clock)
S3	Y-axis 60 arcsec (cables @ 3 o'clock)
S4	Y-axis 60 arcsec (cables @ 9 o'clock)
S5	Y-axis 15 arcsec (cables @ 3 o'clock)
S6	Y-axis 15 arcsec (cables @ 9 o'clock)

## MX80M

	1	2	3	4	5	6	7	8	9
Order example	<b>MX80M</b>	<b>T02</b>	<b>M</b>	<b>S</b>	<b>C2</b>	<b>D22</b>	<b>R1</b>	<b>X4</b>	<b>S1</b>

<b>1</b>	<b>Series</b>	
	MX80M	
<b>2</b>	<b>Travel - mm</b>	
	T01	25
	T02	50
<b>3</b>	<b>Mounting</b>	
	M	Metric
<b>4</b>	<b>Grade</b>	
	S	Standard
<b>5</b>	<b>Type</b>	
	C1	None - free travel/idler
	C2	Center drive
	C3	Lateral drive
<b>6</b>	<b>Drive type</b>	
	D1	None
	D20	Metric micrometer
	D21	English micrometer
	D22	Digital micrometer
<b>7</b>	<b>Finish</b>	
	R1	Standard finish (black anodized)
	R2	Cleanroom preparation
	R10	Low ESD finish
	R20	Low ESD finish & cleanroom preparation
<b>8</b>	<b>Lock option</b>	
	X1	None
	X4	With lock
<b>9</b>	<b>Axis designator</b>	
	S1	None (single-axis)
	S2	X-axis base unit (micrometer @12 o'clock)
	S3	Y-axis 60 arcsec (micrometer @3 o'clock)
	S4	Y-axis 60 arcsec (micrometer @9 o'clock)
	S5	Y-axis 15 arcsec (micrometer @3 o'clock)
	S6	Y-axis 15 arcsec (micrometer @9 o'clock)







# Parker's Motion & Control Technologies

At Parker, we're guided by a relentless drive to help our customers become more productive and achieve higher levels of profitability by engineering the best systems for their requirements. It means looking at customer applications from many angles to find new ways to create value. Whatever the motion and control technology need, Parker has the experience, breadth of product and global reach to consistently deliver. No company knows more about motion and control technology than Parker. For further info call 00800 27 27 5374.



## AEROSPACE

### Key Markets

- Aircraft engines
- Business & general aviation
- Commercial transports
- Land-based weapons systems
- Military aircraft
- Missiles & launch vehicles
- Regional transports
- Unmanned aerial vehicles

### Key Products

- Flight control systems & components
- Fluid conveyance systems
- Fluid metering delivery & atomization devices
- Fuel systems & components
- Hydraulic systems & components
- Inert nitrogen generating systems
- Pneumatic systems & components
- Wheels & brakes



## CLIMATE CONTROL

### Key Markets

- Agriculture
- Air conditioning
- Food, beverage & dairy
- Life sciences & medical
- Precision cooling
- Processing
- Transportation

### Key Products

- CO<sub>2</sub> controls
- Electronic controllers
- Filter driers
- Hand shut-off valves
- Hose & fittings
- Pressure regulating valves
- Refrigerant distributors
- Safety relief valves
- Solenoid valves
- Thermostatic expansion valves



## ELECTROMECHANICAL

### Key Markets

- Aerospace
- Factory automation
- Food & beverage
- Life science & medical
- Machine tools
- Packaging machinery
- Paper machinery
- Plastics machinery & converting
- Primary metals
- Semiconductor & electronics
- Textile
- Wire & cable

### Key Products

- AC/DC drives & systems
- Electric actuators
- Controllers
- Gantry robots
- Gearheads
- Human machine interfaces
- Industrial PCs
- Inverters
- Linear motors, slides and stages
- Precision stages
- Stepper motors
- Servo motors, drives & controls
- Structural extrusions



## FILTRATION

### Key Markets

- Food & beverage
- Industrial machinery
- Life sciences
- Marine
- Mobile equipment
- Oil & gas
- Power generation
- Process
- Transportation

### Key Products

- Analytical gas generators
- Compressed air & gas filters
- Condition monitoring
- Engine air, fuel & oil filtration & systems
- Hydraulic, lubrication & coolant filters
- Process, chemical, water & microfiltration filters
- Nitrogen, hydrogen & zero air generators



## FLUID & GAS HANDLING

### Key Markets

- Aerospace
- Agriculture
- Bulk chemical handling
- Construction machinery
- Food & beverage
- Fuel & gas delivery
- Industrial machinery
- Mobile
- Oil & gas
- Transportation
- Welding

### Key Products

- Brass fittings & valves
- Diagnostic equipment
- Fluid conveyance systems
- Industrial hose
- PTFE & PFA hose, tubing & plastic fittings
- Rubber & thermoplastic hose & couplings
- Tube fittings & adapters
- Quick disconnects



## HYDRAULICS

### Key Markets

- Aerospace
- Aerial lift
- Agriculture
- Construction machinery
- Forestry
- Industrial machinery
- Mining
- Oil & gas
- Power generation & energy
- Truck hydraulics

### Key Products

- Diagnostic equipment
- Hydraulic cylinders & accumulators
- Hydraulic motors & pumps
- Hydraulic systems
- Hydraulic valves & controls
- Power take-offs
- Rubber & thermoplastic hose & couplings
- Tube fittings & adapters
- Quick disconnects



## PNEUMATICS

### Key Markets

- Aerospace
- Conveyor & material handling
- Factory automation
- Food & beverage
- Life science & medical
- Machine tools
- Packaging machinery
- Transportation & automotive

### Key Products

- Air preparation
- Compact cylinders
- Field bus valve systems
- Grippers
- Guided cylinders
- Manifolds
- Miniature fluidics
- Pneumatic accessories
- Pneumatic actuators & grippers
- Pneumatic valves and controls
- Rodless cylinders
- Rotary actuators
- Tie rod cylinders
- Vacuum generators, cups & sensors



## PROCESS CONTROL

### Key Markets

- Chemical & refining
- Food, beverage & dairy
- Medical & dental
- Microelectronics
- Oil & gas
- Power generation

### Key Products

- Analytical sample conditioning products & systems
- Fluoropolymer chemical delivery fittings, valves & pumps
- High purity gas delivery fittings, valves & regulators
- Instrumentation fittings, valves & regulators
- Medium pressure fittings & valves
- Process control manifolds



## SEALING & SHIELDING

### Key Markets

- Aerospace
- Chemical processing
- Consumer
- Energy, oil & gas
- Fluid power
- General industrial
- Information technology
- Life sciences
- Military
- Semiconductor
- Telecommunications
- Transportation

### Key Products

- Dynamic seals
- Elastomeric o-rings
- EMI shielding
- Extruded & precision-cut, fabricated elastomeric seals
- Homogeneous & inserted elastomeric shapes
- High temperature metal seals
- Metal & plastic retained composite seals
- Thermal management

# Parker Worldwide

## Europe, Middle East, Africa

**AE – United Arab Emirates, Dubai**  
Tel: +971 4 8127100  
parker.me@parker.com

**AT – Austria, Wiener Neustadt**  
Tel: +43 (0)2622 23501-0  
parker.austria@parker.com

**AT – Eastern Europe, Wiener Neustadt**  
Tel: +43 (0)2622 23501 900  
parker.easteurope@parker.com

**AZ – Azerbaijan, Baku**  
Tel: +994 50 2233 458  
parker.azerbaijan@parker.com

**BE/LU – Belgium, Nivelles**  
Tel: +32 (0)67 280 900  
parker.belgium@parker.com

**BG – Bulgaria, Sofia**  
Tel: +359 2 980 1344  
parker.bulgaria@parker.com

**BY – Belarus, Minsk**  
Tel: +375 17 209 9399  
parker.belarus@parker.com

**CH – Switzerland, Etoy**  
Tel: +41 (0)21 821 87 00  
parker.switzerland@parker.com

**CZ – Czech Republic, Klecany**  
Tel: +420 284 083 111  
parker.czechrepublic@parker.com

**DE – Germany, Kaarst**  
Tel: +49 (0)2131 4016 0  
parker.germany@parker.com

**DK – Denmark, Ballerup**  
Tel: +45 43 56 04 00  
parker.denmark@parker.com

**ES – Spain, Madrid**  
Tel: +34 902 330 001  
parker.spain@parker.com

**FI – Finland, Vantaa**  
Tel: +358 (0)20 753 2500  
parker.finland@parker.com

**FR – France, Contamine s/Arve**  
Tel: +33 (0)4 50 25 80 25  
parker.france@parker.com

**GR – Greece, Athens**  
Tel: +30 210 933 6450  
parker.greece@parker.com

**HU – Hungary, Budaörs**  
Tel: +36 23 885 470  
parker.hungary@parker.com

**IE – Ireland, Dublin**  
Tel: +353 (0)1 466 6370  
parker.ireland@parker.com

**IT – Italy, Corsico (MI)**  
Tel: +39 02 45 19 21  
parker.italy@parker.com

**KZ – Kazakhstan, Almaty**  
Tel: +7 7273 561 000  
parker.easteurope@parker.com

**NL – The Netherlands, Oldenzaal**  
Tel: +31 (0)541 585 000  
parker.nl@parker.com

**NO – Norway, Asker**  
Tel: +47 66 75 34 00  
parker.norway@parker.com

**PL – Poland, Warsaw**  
Tel: +48 (0)22 573 24 00  
parker.poland@parker.com

**PT – Portugal, Leca da Palmeira**  
Tel: +351 22 999 7360  
parker.portugal@parker.com

**RO – Romania, Bucharest**  
Tel: +40 21 252 1382  
parker.romania@parker.com

**RU – Russia, Moscow**  
Tel: +7 495 645-2156  
parker.russia@parker.com

**SE – Sweden, Spånga**  
Tel: +46 (0)8 59 79 50 00  
parker.sweden@parker.com

**SK – Slovakia, Banská Bystrica**  
Tel: +421 484 162 252  
parker.slovakia@parker.com

**SL – Slovenia, Novo Mesto**  
Tel: +386 7 337 6650  
parker.slovenia@parker.com

**TR – Turkey, Istanbul**  
Tel: +90 216 4997081  
parker.turkey@parker.com

**UA – Ukraine, Kiev**  
Tel: +380 44 494 2731  
parker.ukraine@parker.com

**UK – United Kingdom, Warwick**  
Tel: +44 (0)1926 317 878  
parker.uk@parker.com

**ZA – South Africa, Kempton Park**  
Tel: +27 (0)11 961 0700  
parker.southafrica@parker.com

## North America

**CA – Canada, Milton, Ontario**  
Tel: +1 905 693 3000

**US – USA, Cleveland**  
Tel: +1 216 896 3000

## Asia Pacific

**AU – Australia, Castle Hill**  
Tel: +61 (0)2-9634 7777

**CN – China, Shanghai**  
Tel: +86 21 2899 5000

**HK – Hong Kong**  
Tel: +852 2428 8008

**IN – India, Mumbai**  
Tel: +91 22 6513 7081-85

**JP – Japan, Tokyo**  
Tel: +81 (0)3 6408 3901

**KR – South Korea, Seoul**  
Tel: +82 2 559 0400

**MY – Malaysia, Shah Alam**  
Tel: +60 3 7849 0800

**NZ – New Zealand, Mt Wellington**  
Tel: +64 9 574 1744

**SG – Singapore**  
Tel: +65 6887 6300

**TH – Thailand, Bangkok**  
Tel: +662 186 7000-99

**TW – Taiwan, Taipei**  
Tel: +886 2 2298 8987

## South America

**AR – Argentina, Buenos Aires**  
Tel: +54 3327 44 4129

**BR – Brazil, Sao Jose dos Campos**  
Tel: +55 800 727 5374

**CL – Chile, Santiago**  
Tel: +56 2 623 1216

**MX – Mexico, Apodaca**  
Tel: +52 81 8156 6000



### EMEA Product Information Centre

Free phone: 00 800 27 27 5374

(from AT, BE, CH, CZ, DE, DK, EE, ES, FI, FR, IE, IL, IS, IT, LU, MT, NL, NO, PL, PT, RU, SE, SK, UK, ZA)

### US Product Information Centre

Toll-free number: 1-800-27 27 537

www.parker.com