

# Auto-tune PID Temperature Controller



## FEATURES

- Easy-to-use
- Fuzzy modified PID heat & cool control
- Fast A-D sampling rate (5 times/s)
- Universal input (PT100, thermocouple) with high accuracy 18-bit A-D
- Analog output (linear current or voltage) uses high accuracy 15-bit D-A
- RS-485 RS-232 interface
- Programming port provided on board
- Support manual control & auto-tune function
- Wide variety of alarm mode selection
- Lockout protection control
- Bumpless transfer during failure mode
- Soft-start ramp and dwell timer
- Bright display stabilized with digital filter
- SEL function allows to rearrange user menu
- UL/CSA/CE approval
- High performance with low cost



BTC-4100



BTC-7100



BTC-8100



BTC-9100



## Overview

The Fuzzy Logic plus PID microprocessor-based controller series, incorporate two bright, easy to read 4-digit LED displays, indicating process value and set point value. The Fuzzy Logic technology enables a process to reach a predetermined set point in the shortest time, with the minimum of overshoot during power-up or external load disturbance.

BTC-9100 is a 1/16 DIN size panel mount controller. BTC-7100 is a 72X72 DIN size panel mount controller. BTC-8100 is a 1/8 DIN size panel mount controller and BTC-4100 is a 1/4 DIN size panel mount controller. These units are powered by 11-26 or 90-250 VDC/VAC supply, incorporating a 2 amp. control relay output as standard. The second output can be used as cooling control, or an alarm. Both outputs can select triac, 5V logic output, linear current or linear voltage to drive external device. There are six types of alarm plus a dwell timer can be configured for the third output. The units are fully programmable for PT100 and thermocouple types J, K, T, E, B, R, S, N, L with no need to modify the unit. The input signal is digitized by using a 18-bit A to D converter. Its fast sampling rate allows the unit to control fast processes.

Digital communications RS-485 or RS-232 ( for BTC-9100, BTC-8100, BTC-4100 ) are available as an additional option. These options allow the units to be integrated with supervisory control system and software.

A programming port is available for automatic configuration, calibration and testing without the need to access the keys on front panel.

By using proprietary Fuzzy modified PID technology, the control loop will minimize the overshoot and undershoot in a shortest time. The following diagram is a comparison of results with and without Fuzzy technology.

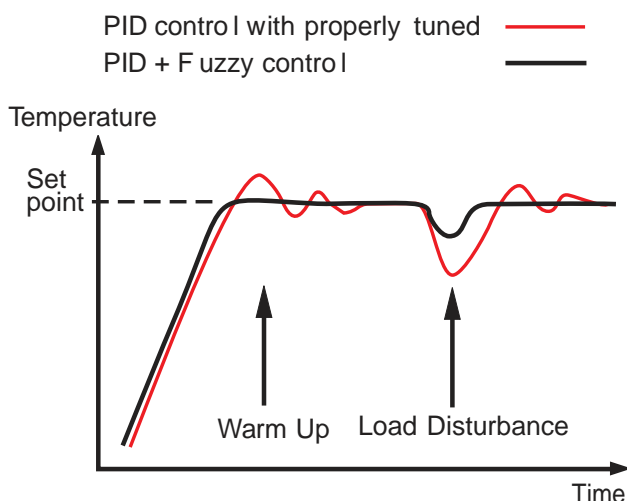

### High Accuracy

The series are manufactured with custom designed ASIC (Application Specific Integrated Circuit) technology which contains a 18-bit A to D converter for high resolution measurement ( true 0.1°F resolution for thermocouple and PT100 ) and a 15-bit D to A converter for linear current or voltage control output. The ASIC technology provides improved operating performance, low cost, enhanced reliability and higher density.

### Fast Sampling Rate

The sampling rate of the input A to D converter reaches 5 times/second. The fast sampling rate allows this series to control fast processes.

### Fuzzy Control

The function of Fuzzy control is to adjust PID parameters from time to time in order to make manipulation output value more flexible and adaptive to various processes. The results is to enable a process to reach a predetermined set point in the shortest time, with the minimum of overshoot and undershoot during power-up or external load disturbance.

### Digital Communication

The units are equipped with RS-485 or RS-232 interface card to provide digital communication. By using the twisted pair wires there are at most 247 units can be connected together via RS-485 interface to a host computer.

### Programming Port

A programming port is used to connect the unit to a pc for quick configuration, also can be connected to an ATE system for automatic testing & calibration.

### Auto-tune

The auto-tune function allows the user to simplify initial setup for a new system. A clever algorithm is provided to obtain an optimal set of control parameters for the process, and it can be applied either as the process is warming up ( cold start ) or as the process has been in steady state ( warm start ).

### Lockout Protection

According to actual security requirement, one of four lockout levels can be selected to prevent the unit from being changed abnormally.

### Bumpless Transfer

Bumpless transfer allows the controller to continue to control by using its previous value as the sensor breaks. Hence, the process can be well controlled temporarily as if the sensor is normal.

### Soft-start Ramp

The ramping function is performed during power up as well as any time the set point is changed. It can be ramping up or ramping down. The process value will reach the set point with a predetermined constant rate.

### Digital Filter

A first order low pass filter with a programmable time constant is used to improve the stability of process value. This is particularly useful in certain application where the process value is too unstable to be read.

### SEL Function

The units have the flexibility for user to select those parameters which are most significant to him and put these parameters in the front of display sequence. There are at most 8 parameters can be selected to allow the user to build his own display sequence.

# Specifications

## Power

90-250 VAC, 47-63 Hz, 12VA, 5W maximum  
11-26 VAC / VDC, 12VA, 5W maximum

## Signal Input

**Resolution** : 18 bits  
**Sampling Rate** : 5 times / second  
**Maximum Rating** : -2 VDC minimum, 12 VDC maximum  
( 1 minute for mA input )  
**Temperature Effect** :  $\pm 1.5$   $\mu\text{V}/^\circ\text{C}$  for all inputs except  
mA input  
 $\pm 3.0$   $\mu\text{V}/^\circ\text{C}$  for mA input

### Sensor Lead Resistance Effect :

T/C: 0.2 $\mu\text{V}/\text{ohm}$   
3-wire RTD: 2.6 $^\circ\text{C}/\text{ohm}$  of resistance difference of two leads  
2-wire RTD: 2.6 $^\circ\text{C}/\text{ohm}$  of resistance sum of two leads

### Burn-out Current : 200nA

### Common Mode Rejection Ratio ( CMRR ) : 120dB

### Normal Mode Rejection Ratio ( NMRR ) : 55dB

### Sensor Break Detection :

Sensor open for TC, RTD and mV inputs,  
Sensor short for RTD input,  
below 1 mA for 4-20 mA input,  
below 0.25V for 1 - 5 V input,  
unavailable for other inputs.

### Sensor Break Responding Time :

Within 4 seconds for TC, RTD and mV inputs,  
0.1 second for 4-20 mA and 1 - 5 V inputs.

## Characteristics

Type	Range	Accuracy @25 $^\circ\text{C}$	Input Impedance
J	-120 $^\circ\text{C}$ -1000 $^\circ\text{C}$ (-184 $^\circ\text{F}$ -1832 $^\circ\text{F}$ )	$\pm 2^\circ\text{C}$	2.2M $\Omega$
K	-200 $^\circ\text{C}$ -1370 $^\circ\text{C}$ (-328 $^\circ\text{F}$ -2498 $^\circ\text{F}$ )	$\pm 2^\circ\text{C}$	2.2M $\Omega$
T	-250 $^\circ\text{C}$ -400 $^\circ\text{C}$ (-418 $^\circ\text{F}$ -752 $^\circ\text{F}$ )	$\pm 2^\circ\text{C}$	2.2M $\Omega$
E	-100 $^\circ\text{C}$ -900 $^\circ\text{C}$ (-148 $^\circ\text{F}$ -1652 $^\circ\text{F}$ )	$\pm 2^\circ\text{C}$	2.2M $\Omega$
B	0 $^\circ\text{C}$ -1800 $^\circ\text{C}$ (32 $^\circ\text{F}$ -3272 $^\circ\text{F}$ )	$\pm 2^\circ\text{C}$ (200 $^\circ\text{C}$ -1800 $^\circ\text{C}$ )	2.2M $\Omega$
R	0 $^\circ\text{C}$ -1767.8 $^\circ\text{C}$ (32 $^\circ\text{F}$ -3214 $^\circ\text{F}$ )	$\pm 2^\circ\text{C}$	2.2M $\Omega$
S	0 $^\circ\text{C}$ -1767.8 $^\circ\text{C}$ (32 $^\circ\text{F}$ -3214 $^\circ\text{F}$ )	$\pm 2^\circ\text{C}$	2.2M $\Omega$
N	-250 $^\circ\text{C}$ -1300 $^\circ\text{C}$ (-418 $^\circ\text{F}$ -2372 $^\circ\text{F}$ )	$\pm 2^\circ\text{C}$	2.2M $\Omega$
L	-200 $^\circ\text{C}$ -900 $^\circ\text{C}$ (-328 $^\circ\text{F}$ -1652 $^\circ\text{F}$ )	$\pm 2^\circ\text{C}$	2.2M $\Omega$
PT100 (DIN)	-210 $^\circ\text{C}$ -700 $^\circ\text{C}$ (-346 $^\circ\text{F}$ -1292 $^\circ\text{F}$ )	$\pm 0.4^\circ\text{C}$	1.3K $\Omega$
PT100 (JIS)	-200 $^\circ\text{C}$ -600 $^\circ\text{C}$ (-328 $^\circ\text{F}$ -1112 $^\circ\text{F}$ )	$\pm 0.4^\circ\text{C}$	1.3K $\Omega$
mV	-8mV - 70mV	$\pm 0.05\%$	2.2M $\Omega$
mA	-3mA - 27mA	$\pm 0.05\%$	70.5 $\Omega$
V	-1.3V - 11.5V	$\pm 0.05\%$	650K $\Omega$

## Output 1 / Output 2

**Relay Rating** : 2A/240 VAC, life cycles 200,000 for  
resistive load

**Pulsed Voltage** : Source Voltage 5V,  
current limiting resistance 66 $\Omega$ .

### Linear Output Characteristics

Type	Zero Tolerance	Span Tolerance	Load Capacity
4-20 mA	3.6-4 mA	20-21 mA	500 $\Omega$ max.
0-20 mA	0 mA	20-21 mA	500 $\Omega$ max.
0-5 V	0 V	5-5.25 V	10 K $\Omega$ min.
1-5 V	0.9-1 V	5-5.25 V	10 K $\Omega$ min.
0-10 V	0 V	10-10.5 V	10 K $\Omega$ min.

## Linear Output

**Resolution** : 15 bits  
**Output Regulation** : 0.02 % for full load change  
**Output Settling Time** : 0.1 sec. ( stable to 99.9 % )  
**Isolation Breakdown Voltage** : 1000 VAC  
**Temperature Effect** :  $\pm 0.01$  % of SPAN /  $^\circ\text{C}$

## Triac ( SSR ) Output

**Rating** : 1A / 240 VAC  
**Inrush Current** : 20A for 1 cycle  
**Min. Load Current** : 50 mA rms  
**Max. Off-state Leakage** : 3 mA rms  
**Max. On-state Voltage** : 1.5 V rms  
**Insulation Resistance** : 1000 Mohms min. at 500 VDC  
**Dielectric Strength** : 2500 VAC for 1 minute

## Alarm

**Alarm Relay** : Form C, Max. rating 2A/240VAC,  
life cycles 200,000 for resistive load.

**Alarm Functions** : Dwell timer,  
Deviation High / Low Alarm,  
Deviation Band High / Low Alarm,  
Process High / Low Alarm,

**Alarm Mode** : Normal, Latching, Hold, Latching / Hold.  
**Dwell Timer** : 0.1 - 4553.6 minutes

## Data Communication

**Interface** : RS-232 ( 1 unit ), RS-485 ( up to 247 units )  
**Protocol** : Modbus Protocol RTU mode  
**Address** : 1 - 247  
**Baud Rate** : 2.4 ~ 38.4 Kbits/sec  
**Data Bits** : 7 or 8 bits  
**Parity Bit** : None, Even or Odd  
**Stop Bit** : 1 or 2 bits  
**Communication Buffer** : 160 bytes

## Analog Retransmission

**Output Signal** : 4-20mA, 0-20mA, 0-5V, 1-5V, 0-10V  
**Resolution** : 15 bits  
**Accuracy** :  $\pm 0.05\%$  of span  $\pm 0.0025\%/^\circ\text{C}$   
**Load Resistance** : 0-500 ohm (for current output)  
10K ohm minimum (for voltage output)  
**Output Regulation** : 0.01% for full load change

## User Interface

**Dual 4-digit LED Displays** :  
BTC-4100  
Upper 0.55" ( 14mm )  
Lower 0.4" ( 10 mm )

BTC-8100, BTC-7100, BTC-9100  
 Upper 0.4" ( 10 mm )  
 Lower 0.31" ( 8 mm )

**Keypad** : 4 keys

**Programming Port** : For automatic setup, calibration and testing

**Communication Port** : Connection to PC for supervisory control

### Control Mode

**Output 1** : Reverse ( heating ) or direct ( cooling ) action

**Output 2** : PID cooling control, cooling P band 50 ~ 300% of PB, dead band -36.0~36.0% of PB

**ON-OFF** : 0.1 - 90.0 ( °F ) hysteresis control ( P band = 0 )

**P or PD** : 0 - 100.0 % offset adjustment

**PID** : Fuzzy logic modified  
 Proportional band 0.1 ~ 900.0°F.  
 Integral time 0 - 1000 seconds  
 Derivative time 0 - 360.0 seconds

**Cycle Time** : 0.1 - 90.0 seconds

**Manual Control** : Heat (MV1) and Cool (MV2)

**Auto-tuning** : Cold start and warm start

**Failure Mode** : Auto-transfer to manual mode while sensor break or A-D converter damage

**Ramping Control** : 0 - 900.0°F/minute or 0 - 900.0°F/hour ramp rate

### Digital Filter

**Function** : First order

**Time Constant** : 0, 0.2, 0.5, 1, 2, 5, 10, 20, 30, 60 seconds programmable

### Environmental & Physical

**Operating Temperature** : -10°C to 50°C

**Storage Temperature** : -40°C to 60°C

**Humidity** : 0 to 90 % RH ( non-condensing )

**Altitude** : 2000m maximum

**Pollution** : Degree 2

**Insulation Resistance** : 20 Mohms min. ( at 500 VDC )

**Dielectric Strength** : 2000 VAC, 50/60 Hz for 1 minute

**Vibration Resistance** : 10 - 55 Hz, 10 m/s<sup>2</sup> for 2 hours

**Shock Resistance** : 200 m/s<sup>2</sup> ( 20 g )

**Moldings** : Flame retardant polycarbonate

**Dimensions** :

BTC-4100 ---96mm(W) X 96mm(H) X 65 mm(D),  
 53 mm depth behind panel

BTC-7100 ---72mm(W) X 72mm(H) X 78.2 mm(D),  
 65 mm depth behind panel

BTC-8100 ---48mm(W) X 96mm(H) X 80mm(D),  
 65 mm depth behind panel

BTC-9100 ---48mm(W) X 48mm(H) X 116mm(D),  
 105 mm depth behind panel

**Mounting**:

BTC-4100 ---panel mount, cutout 92 X 92 ( mm )

BTC-7100 ---panel mount, cutout 68 X 68 ( mm )

BTC-8100 ---panel mount, cutout 45 X 92 ( mm )

BTC-9100 ---panel mount, cutout 45 X 45 ( mm )

**Weight** : BTC-4100 --- 250 grams

BTC-7100 --- 200 grams

BTC-8100 --- 210 grams

BTC-9100 --- 150 grams

### Approval Standards

**Safety** : UL61010C-1

CSA C22.2 No. 24-93

EN61010-1 ( IEC1010-1 )

**Protective Class** :

IP65 front panel with additional option,

IP50 front panel without additional option,

all indoor use,

IP 20 housing and terminals with protective cover.

**EMC**: EN61326

### Connection Diagrams

#### BTC-9100

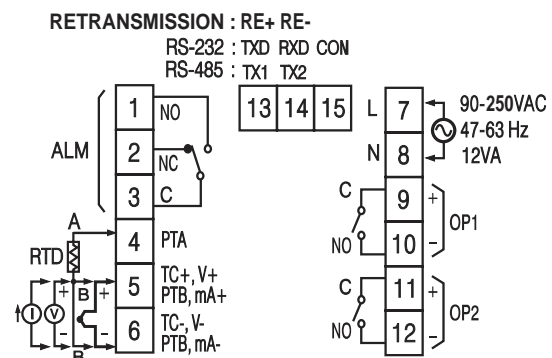

#### BTC-7100

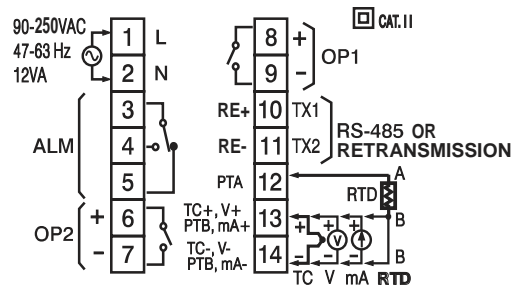

#### BTC-8100, BTC-4100

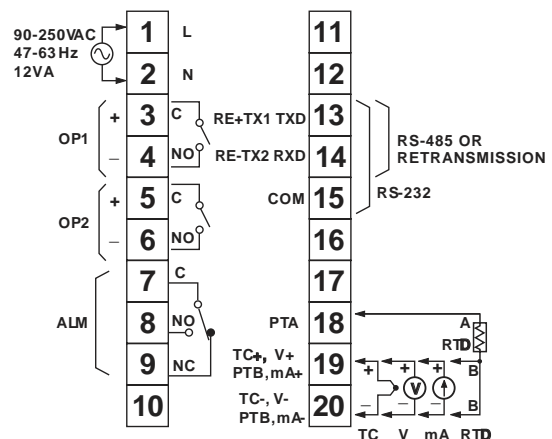

## Ordering Code

**BTC-9100 -**   
**BTC-8100 -**   
**BTC-7100 -**   
**BTC-4100 -**

### Power Input

4: 90 - 250 VAC, 50/60 HZ  
 5: 11 - 26 VAC or VDC  
 9: Special Order

### Signal Input

1: Standard Input  
 Thermocouple: J, K, T, E, B,  
 R, S, N, L  
 RTD: PT100 DIN, PT100 JIS  
 2: 0 - 60 mV  
 3: 0 - 1 V  
 4: 0 - 5 V  
 5: 1 - 5 V  
 6: 4 - 20 mA  
 7: 0 - 20 mA  
 8: 0 - 10V  
 9: Special Order

### Output 1

0: None  
 1: Relay rated 2A/240VAC  
 2: Pulsed voltage to  
 drive SSR, 5V/30mA  
 3: Isolated 4 - 20mA / 0 - 20mA  
 4: Isolated 1 - 5V / 0 - 5V  
 5: Isolated 0 - 10V  
 6: Triac output, 1A / 240VAC, SSR  
 C: Pulsed voltage to drive SSR, 14V/40mA  
 9: Special order

### Options

0: Panel mount IP50 standard  
 1: Panel mount IP65 water  
 resistant rubber installed  
 2: DIN Rail mount with IP50  
 (for BTC-9100 only)  
 3: DIN Rail mount with IP65  
 (for BTC-9100 only)

### Communications

0: None  
 1: RS-485 interface  
 2: RS-232 interface(not available for BTC-7100)  
 3: Retransmit 4-20mA / 0-20mA  
 4: Retransmit 1-5V / 0-5V  
 5: Retransmit 0-10V  
 9: Special order

### Alarm

0: None  
 1: Form C relay 2A/240VAC  
 9: Special order

### Output 2

0: None  
 1: Form A relay 2A/240VAC  
 2: Pulsed voltage to  
 drive SSR, 5V/30mA  
 3: Isolated 4 - 20mA / 0 - 20mA  
 4: Isolated 1 - 5V / 0 - 5V  
 5: Isolated 0 - 10V  
 6: Triac output, 1A / 240VAC, SSR  
 7: Isolated 20V/25mA Transducer  
 Power Supply  
 8: Isolated 12V/40mA Transducer  
 Power Supply  
 9: Isolated 5V/80mA Transducer  
 Power Supply  
 C: Pulsed voltage to drive SSR, 14V/40mA  
 A: Special order

Standard model without option

BTC-x100-4110000: power 90-250VAC, standard input thermocouple + PT100,

output 1 - relay, output 2 - none, alarm - none, communication - none, panel mount IP50 standard

## ***Accessories***

---

OM94-6 = Isolated 1A / 240VAC Triac Output Module ( SSR )  
OM94-7 = 14V / 40mA SSR Drive Module  
OM96-3 = Isolated 4 - 20 mA / 0 - 20 mA Analog Output Module  
OM96-4 = Isolated 1 - 5V / 0 - 5V Analog Output Module  
OM96-5 = Isolated 0 - 10V Analog Output Module  
CM94-1 = Isolated RS-485 Interface Module for BTC-7100 / 8100 / 4100  
CM94-2 = Isolated RS-232 Interface Module for BTC-8100 / 4100  
CM94-3 = Isolated 4-20mA / 0-20mA Retrains Module for BTC-8100 / 4100 / 7100  
CM94-4 = Isolated 1-5V / 0-5V Retrains Module for BTC-8100 / 4100 / 7100  
CM94-5 = Isolated 0-10V Retrains Module for BTC-8100 / 4100 / 7100  
CM97-1 = Isolated RS-485 Interface Module for BTC-9100  
CM97-2 = Isolated RS-232 Interface Module for BTC-9100  
CM97-3 = Isolated 4-20mA / 0-20mA Retrains Module for BTC-9100  
CM97-4 = Isolated 1-5V / 0-5V Retrains Module for BTC-9100  
CM97-5 = Isolated 0-10V Retrains Module for BTC-9100  
DC94-1 = Isolated 20V / 25mA DC Output Power Supply  
DC94-2 = Isolated 12V / 40mA DC Output Power Supply  
DC94-3 = Isolated 5V / 80mA DC Output Power Supply  
CC94-1 = RS-232 Interface Cable ( 2M )  
CC91-1 = Programming Port Cable  
RK91-1 = Rail Mount kit for BTC-9100

## ***Related Products***

---

SNA10A = Smart Network Adaptor for third party software,  
which converts 255 channels of RS-485 or RS-422  
to RS-232 Network.  
SNA10B = Smart Network Adaptor for BC-Net software,  
which converts 255 channels of RS-485 or RS-422  
to RS-232 network.  
SNA12A = Smart Network Adaptor for programming port to  
RS-232 interface.  
BC-Set = Configuration Software

