

## MRTALP611LDCS

### Standard Pad Spread\*:

- Minimum Width - 12" [305 mm]
- Maximum Width - 52-3/4" [1340 mm]
- Minimum Length - 35-1/2" [902 mm]
- Maximum Length - 102" [2593 mm]

### Number / Size of Pads:

- 6 / 11" [28 cm] dia. lipped vacuum pads

### Load Capacity\*:

- Maximum - 1100 lbs [500 kg]
- Per-Pad - 184 lbs [83.5 kg]

(On smooth, nonporous surfaces.  
Please contact us for recommendations on other surfaces.)

### Unit Weight: 213 lbs [97 kg]

### Standard Operating Power: 12 volts DC, 10 amps

- Load Movement:** Manual rotation, 180° edgewise, with automatic latching every 30°
- Assisted manual tilt, 90° between upright and flat, with automatic latching in upright position

### Profile Thickness: 8" [203 mm] (does not include load)

- Dual vacuum system
- Low vacuum warning buzzer
- Green lift light
- On-board battery and charger
- Battery energy gauge
- Vacuum gauges
- Vacuum line filters
- Vacuum reserve tanks
- Spring-mounted vacuum pads
- (Re)movable vacuum pad mounts
- Vacuum pad extension arms
- Blow-off for quick release

\* See Frame Configurations and Capacities.

In addition to DC power and a dual vacuum system, this Powr-Grip® rotator/tilter features a highly adaptable pad frame and a remarkably low profile, for maximum flexibility in handling loads between buildings and scaffolding or similar tight work locations.

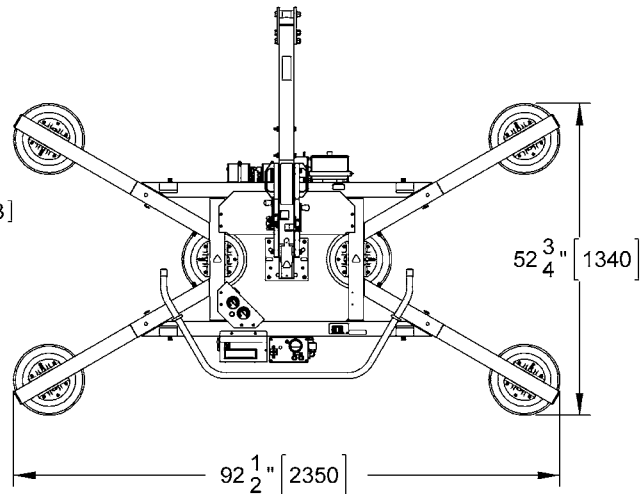
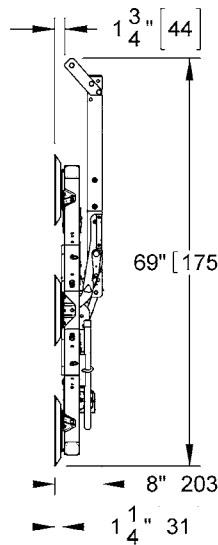

### AVAILABLE OPTIONS:

- Vertical lift bar (LB10VLB)
- Extensions for movable pad mounts (CM6MEVL)
- Alternative vacuum pads:
  - 9" [229 mm] diameter vacuum pad (VPFS9)
  - 10" [254 mm] dia. concave vacuum pad (G0750)
  - 10" [254 mm] dia. lipped vacuum pad (HV11)
- (Specifications not as listed above.)
- Please contact us for more information.)

### DESIGN STANDARDS:

- (See [www.powrgrip.com](http://www.powrgrip.com) for more information.)
- ASME B30.20**
- (BTH-1 Design Category "B", Service Class "0")
- CE**

Based on product information at time of publication.

# FRAME CONFIGURATIONS AND CAPACITIES

