

AVK WATER SUPPLY



**WE DELIVER
PURE
QUALITY
JUST LIKE YOU**



Expect... **AVR**

A COMPLETE RANGE OF VALVES, HYDRANTS AND ACCESSORIES



AVK has been in the valve business for more than 40 years. Today, we are offering solutions for numerous applications including valves, hydrants and accessories for water supply.

The product package covers your needs within hydrants, gate valves and accessories, butterfly valves, control valves, swing check valves, air valves, service connection valves as well as tapping saddles, flange adaptors and couplings.

Facilities of high standards

AVK is unique when it comes to high-quality products. We are second to none when it comes to rubber compounds. We have our own research, vulcanization and coating facilities that enable us to deliver durable products.





Global leadership and local commitment

AVK is a global leader within valves, hydrants, fittings and accessories for water supply, gas supply, wastewater treatment and fire protection and has a strong presence around the world. We offer the local customer access to our global selection of products, standards and expertise.

Our geographical presence and product range are global, but our focus is local. Our customers are serviced by local sales organisations who engage in the customers' needs. AVK is therefore able to offer tailor-made solutions that match local specifications.

The AVK Group is present in more than 80 countries worldwide. Sales and distribution are handled by AVK sales companies, agents and distributors.

A beneficial partnership

We want to build and invest in long-term partnerships with our customers. For us, long-term partnerships not only imply transactions. They are also an opportunity to develop solutions based on valuable input and to innovate for the benefit of our customers.

To earn our role as a long-term partner, we strive to deliver value for money. We deliver flawless, durable and maintenance-free products that constitute the most cost-efficient solution for our partners in the long run.



AVK GATE VALVES RENOWNED FOR SUPERIOR QUALITY

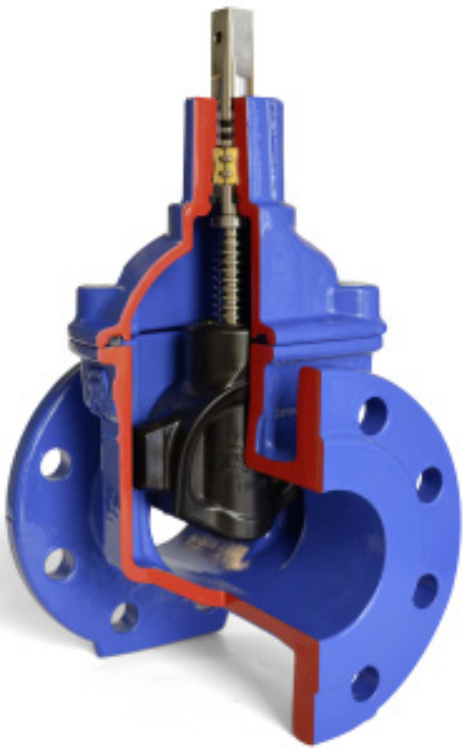

The wedge is the heart of a gate valve and the quality of the wedge rubber is crucial for the valve function and durability. AVK wedges are fully vulcanized with AVK's rubber compound offering outstanding characteristics.

The double bonding vulcanization process ensures maximum adhesion of the rubber and prevents creeping corrosion.

Fixed wedge nut prevents corrosion

AVK's wedge nut design with a fixed, integral wedge nut outperforms the traditional loose wedge nut design as it prevents vibration and thus also corrosion, malfunction and water hammer.

Wedge shoes for smooth operation

The fixed wedge nut and the guide rails fitted with vulcanized wedge shoes secure a smooth operation of the valve and low operating torques. The wedge shoes protect the rubber against the wear which otherwise would arise from friction during operation.

State-of-the-art rubber technology

AVK GUMMI A/S develops and manufactures the rubber compound for wedges and gaskets using highly advanced technologies.

Data is collected throughout the entire manufacturing process which secures traceability of every single ingredient, compound and final component. AVK performs a number of tests to ensure that the compression set values, the adhesion and the tensile strength of the rubber meet the predefined requirements.

Safe operation

The large plain and conical stem hole prevents stagnant water and accumulation of impurities.

The large rubber volume in the sealing area combined with the excellent compression set provide optimum sealing.





Efficient bonding is the key to durability

The wedge core is immersed in two different baths to provide ultimate bonding between core and rubber. Even if a sharp object penetrates the rubber during closing of the valve, the bonding is so strong that there is no risk of creeping corrosion. As a result, we offer the best possible corrosion protection of the wedge.

No contamination of drinking water

The EPDM rubber recipes are composed with focus on minimising the formation of biofilm. The rubber will therefore not provide breeding ground for bacteria.

High resistance

The drinking water approved EPDM compounds are resistant to ozone and water treatment chemicals, and are of course taste, smell and colour neutral.

Excellent ability to regain original shape

AVK GUMMI A/S has a profound knowledge of a rubber's compression set, meaning its ability to regain original shape.

Even after many years of service where the wedge rubber has been compressed numerous times, the rubber will regain its original shape and ensure a tight sealing. Impurities will not affect the tightness of the valve, as the impurities will be absorbed in the rubber when the valve is in closed position and will be flushed away when the valve is reopened.



In closed position impurities are absorbed in the rubber

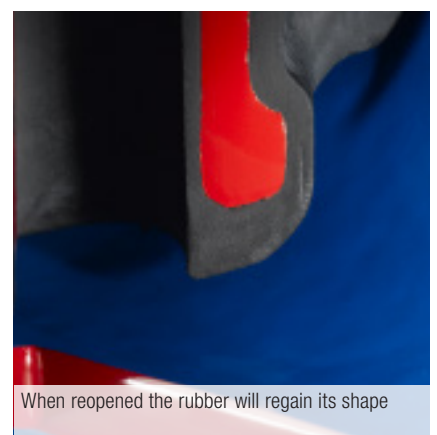

When reopened the rubber will regain its shape

AVK GATE VALVES OFFER UNIQUE FEATURES

Wedge stop and rolled threads

The wedge stop provides a firm stop against the wedge nut when opening the valve. This prevents the wedge from compressing the stem seals and from damaging the coating inside the bonnet. Therefore, the wedge stop gives prolonged durability of the valve.

The stem threads are rolled in a cold pressing process which maintains the steel structure and therefore increases the strength of the stem. This method also ensures a smooth thread surface that gives low operating torques.

Triple safety stem sealing

An NBR wiper ring protects against impurities from the outside. Tightness and low friction are provided by four NBR O-rings in a polyamide bearing. An EPDM manchette is the main seal to the flow.

The full circle thrust collar of dezincification resistant brass provides fixation of the stem and low free running torques.

In DN 450-800 the valves are designed with two roller bearings and a thrust collar of stainless steel to ensure low operating torques.

Two strong coatings

The standard corrosion protection is an internal and external epoxy coating according to DIN 30677-2 and GSK guidelines. Furthermore, we offer gate valves with a highly wear-resistant internal enamel lining offering excellent protection against creeping corrosion.

We control each batch of epoxy coated components to ensure a layer thickness of minimum 250 μ , a pore-free surface, high impact resistance and adequate curing. In addition to our own tests, the independent GSK authorities control the adhesion and cathodic disbonding of the epoxy coating six times a year.

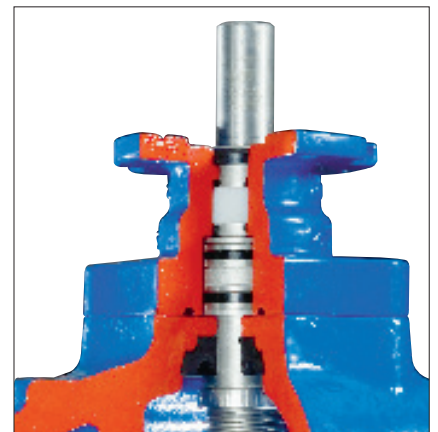
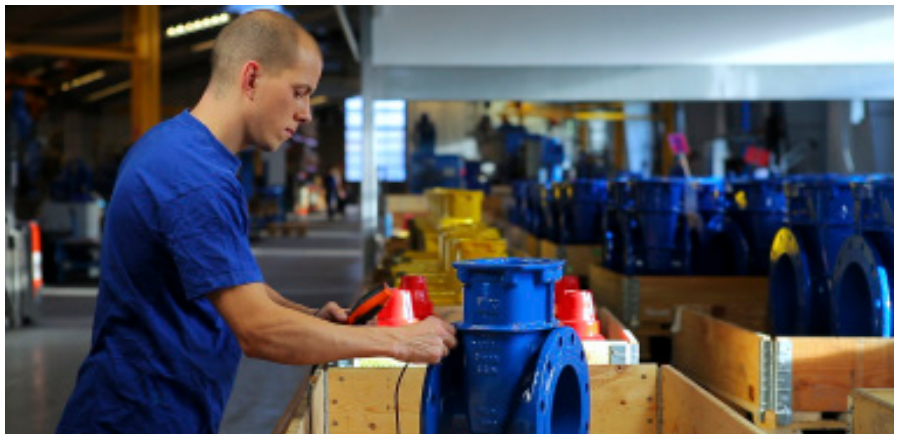
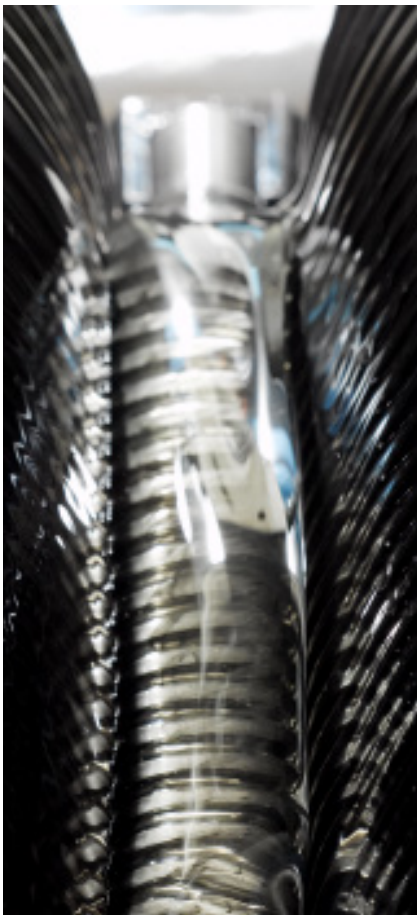



Tight assembly of valve body and bonnet

An EPDM bonnet gasket fits into a recess between the valve body and the bonnet. The stainless steel bonnet bolts are encircled by the bonnet gasket, embedded in the casting to ensure that no threads are exposed to the surroundings, and finally sealed with hot melt to prevent corrosion.

Strong PE end connection

The DVGW approved class 1 connection is stronger than the PE pipe itself. A piece of standard PE pipe is pressed directly onto the grooved valve end. The grooves combined with a sleeve around the valve/pipe connection ensure that the PE pipe material is firmly secured and that the connection remains tight and tensile during the entire service life of the pipeline. The connection is sealed with a shrink hose to provide corrosion protection. The full and straight bore ensures minimum pressure loss and makes underpressure drilling possible.

Pressure test

Every single valve is pressure tested according to EN 1074-1 and 2 / EN 12266 before leaving the factory.



Feature summary

- Fixed, integral wedge nut prevents corrosion caused by vibration
- Wedge and body guide rails ensure stable operation
- AVK's wedge rubber has an excellent ability to regain its shape
- AVK's wedge rubber features an excellent bonding, minimum formation of biofilm and a high resistance to water treatment chemicals
- Large, conical stem hole in the wedge prevents stagnant water
- Rolled threads increase the stem's strength
- Wedge stop protects seals and coating
- Triple safety stem sealing
- Thrust collar provides fixation of the stem and low free running torques
- The bonnet gasket is fixed in a recess in the bonnet and encircles the bonnet bolts to prevent blow-out
- Countersunk bonnet bolts sealed with hot melt to protect against corrosion
- Full bore ensures low head loss and enables use of pipe cleaning devices
- Low operating torques ensure easy operation
- Epoxy coating according to DIN 30677-2 and GSK guidelines, optionally internal enamel

AVK DOUBLE ECCENTRIC BUTTERFLY VALVES THE SAFE CHOICE



AVK offers double eccentric butterfly valves in DN 200-2800 designed with durability in focus. The tilted and firmly secured disc, the optimised seal design and the corrosion protected shaft end zones are features that exceed the market standards.

Tilted and secured disc

The tension on the disc is released after a few degrees of opening which gives only insignificant wear of the disc seal. Furthermore, the design minimises the compression of the sealing which ensures low operating torques.

The disc and shaft are connected by means of a key and a keyway. Furthermore, the key is secured with two set screws to prevent wear of the keyway and thus to avoid fluttering caused by flow velocity and play in the key and keyway connection.

In larger dimensions the disc is fixated with two stainless steel drive dowels, with key and keyway as back-up. The dowels are mounted with press fit leaving no play between disc and shaft.

Two disc designs

Two different disc designs – plate design and flow-through design – are available to meet market requirements worldwide. The flow-through design is less sensitive to cavitation at high flow velocities. This design is available for DN 700-1200 butterfly valves.

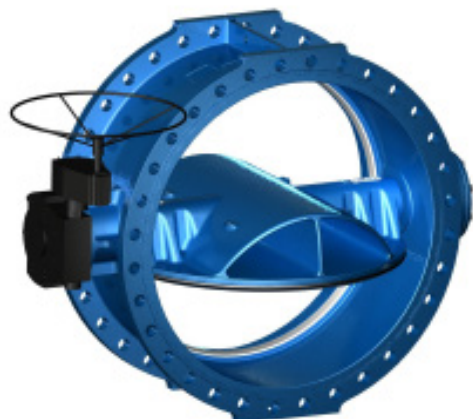



Two seat designs

AVK offers double eccentric butterfly valves with two different seat designs.

The integral seat design has a machined and epoxy coated ductile iron seat integrated in the body.

The stainless steel seat design has a replaceable seat ring of stainless steel sealed with an O-ring. For DN 200-600 valves the ring is pressed into the body, and for larger dimensions the ring is fixed with bolts sealed with epoxy.

Disc seal optimised for high performance

The disc seal is shaped to secure fixation in correct position providing a very reliable function. The excellent rubber quality makes it possible to reduce the amount of rubber which ensures low closing torques. The EPDM sealing is approved by DVGW, KIWA and WRAS.

The stainless steel retainer ring keeps the disc seal in place. It is fixed by stainless steel bolts coated with precoat 80 to prevent loosening. The threaded bolt holes in the disc are corrosion protected with O-rings around the bolt heads.

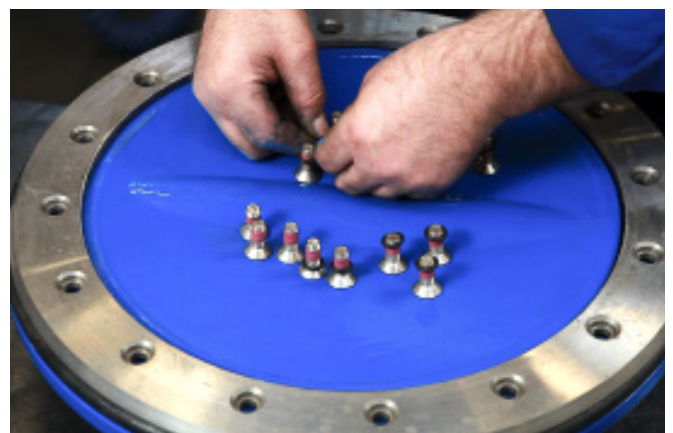

AVK BUTTERFLY VALVES FEATURE PROTECTED SHAFT ENDS



Protected shaft ends secure durability

There are no uncoated ductile iron surfaces exposed to the media. In DN 200-600 the shaft ends are protected with stainless steel plates with gaskets. After mounting and successful pressure test, an extra layer of epoxy coating seals the steel plates. In larger dimensions the shaft ends are fully encapsulated in the disc and fixed to the disc with dowels. The low friction PTFE shaft bearings ensure low operating torques for the complete range.

Design of DN 700-2800

The shaft ends are fully encapsulated in the disc and are fixed with dowels. There are two O-rings on each dowel, which are protected with a stainless steel plate fixed with stainless steel bolts.



Replaceable shaft sealing

The shaft sealing is replaceable under pressure to enable easy maintenance. Sealings of EPDM secure tightness from inside and out, and NBR sealings protect against impurities from outside. The butterfly valves are fitted with a locking device which makes it possible to lock the disc in open/closed position.

Bi-directional and slim design

The valves are bi-directional even though valves from DN 700 and up are marked with an arrow indicating the preferred flow direction.

In addition to all the design features and benefits, AVK has minimised the weight to make handling easier and to put less strain on the environment.

Actuation of your choice

AVK can offer any type of actuation. Our standard options are IP67 gearboxes with handwheel for above ground installation, IP68 gearboxes for buried service, and ISO-input gearboxes for mounting of electrical actuators. Furthermore, we offer extension stems, adaptors and handwheels.

Product approvals

The butterfly valves are approved by:

- DVGW in DN 200-1200
- KIWA in DN 200-600
- WRAS in DN 700-1200

For larger dimensions all components are approved.

Pressure test of every single valve
 The hydraulic test is always done from both directions according to EN 1074-1 and 2 / EN 12266.



AVK CENTRIC BUTTERFLY VALVES FIXED OR LOOSE LINER



AVK offers the widest range of butterfly valves at the market. The fixed liner butterfly valves from AVK are among the very few of its kind and offer outstanding advantages. Furthermore, we offer a wide range of loose liner butterfly valves.

No turbulence or pressure drops

The streamlined disc gives low flow resistance when the valve is open. Therefore, the valves will not cause any turbulence, pressure drops or valve vibration, and will reduce energy costs for the user.

Unique fixed liner design

An outstanding seating concept is the heart of the valve. The rubber is injection moulded directly on the valve body forming a permanent bond with an optimal rubber shore hardness. Consequently, there is no risk of deformation or dislocation of the liner and the valves are therefore suitable even under vacuum conditions.

The disc has a profiled sealing edge which requires minimal deformation of the liner to achieve a tight sealing. This gives less wear of the liner and low operating torques.

Feature summary

- Fixed liner with no risk of deformation or dislocation, thus suitable under vacuum conditions
- AVK rubber liner with excellent ability to regain shape after compression
- Disc with profiled sealing edge gives less wear of liner
- Low operating torques due to fixed liner, profiled disc and shaft bearings
- Streamlined disc prevents turbulence, pressure drops and valve vibration
- Available as wafer, semilug, full lug, double flanged short and double flanged long in DN 40-2000 with any type of actuation

Profiled disc and unique AVK rubber ensure exceptional durability

The unique AVK rubber compound has an excellent ability to regain shape after compression, and this ability combined with the profiled disc secure tightness even after thousands of operation cycles.





Wide range with loose liner

AVK's range of loose liner butterfly valves comprises wafer, lug and U-section butterfly valves in DN 25-1600 with any type of actuation and with a wide selection of disc and liner materials.

A strict control of the coating process and of the tolerances ensures a durable corrosion protection under the liner. Furthermore, it ensures that the liner fits perfectly on the body. This gives low operating torques, and there will be no risk of damaging the coating when compressing the liner.

Feature summary

- Fully coated body with extended neck for insulation
- Square driven anti-blowout shaft in one-piece design up to DN 400, and from DN 450 with key and keyway in two-piece stub design with two self-lubricating bearings
- Disc of acid-resistant stainless steel with machined and polished edges reducing the friction between liner and disc
- EPDM liner for drinking water (70°C) with integrated gasket faces and "saw profile" for optimum grip in the body



AVK SWING CHECK VALVES ENSURE OPTIMUM PUMP PERFORMANCE



AVK offers a wide range of swing check valves featuring full bore and low head loss resulting in maximum utilisation of the pump capacity. The swing check valves can be installed in both horizontal and vertical positions and are easy to maintain.

Unique design

By unscrewing a few bolts the bonnet assembly including hinge and disc can be removed from the body. The hinge is tightened around the shaft with bolts to eliminate play and thus ensure durability.

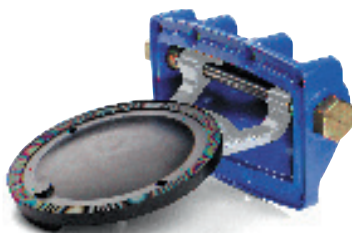

Swing check valves

AVK swing check valves are available in DN 50-600 and feature full bore and low head loss as well as easy access to maintenance and great durability.

Lever and weight appropriate

Swing check valves with lever and weight are appropriate for installations with an increased risk of water hammer at standard velocities.

The solution enables visual check and valves in small dimensions offer the possibility of priming by moving the lever manually. The weight is adjustable on the lever to achieve a soft closing against the seat as well as an optimum closing speed to prevent water hammer.

Feature summary

- Bonnet/disc design gives easy access to maintenance
- Disc with steel insert is fully vulcanized with EPDM rubber (up to DN 300) ensuring optimum sealing ability
- Lip sealing on the disc ensures tightness
- Light-weight disc requires a minimum of force to open and close the valve
- The disc is mounted in a nylon bushing, which allows it to move slightly both horizontally and vertically to close completely tight also in case of minor impurities in the seat
- Hinge tightened around the shaft with bolts to eliminate play and thus ensure durability
- Full bore ensures low head loss
- Ductile iron epoxy coated to DIN 30677-2

A guard covering the lever and weight eliminates the risk of injuries. Optionally with limit switches for remote monitoring.

Swing check valves with lever and external spring are suitable for high pressure, insufficient back pressure and high flow velocities.





AVK AIR VALVES FOR EFFECTIVE PIPELINE OPERATION



Top performance, minimum maintenance and high durability are the characteristics of AVK's wide range of automatic air valves, air and vacuum valves and combination air valves. The air valves are available in composite materials, which combine strength with extremely light weight and increased venting efficiency.

Why use air valves?

Trapped air pockets in the piping system cause many problems:

- Increased corrosion
- Increased energy consumption and operation costs
- Failure or inaccuracies in flow metering
- Pressure loss or even complete flow stop delays in the filling of mains
- Increased risk of water hammer

Sudden movements of air pockets may result in a rapid change in flow velocity, leading to high pressure surges of a destructive nature.

Automatic air valves

AVK automatic air valves series 701 are designed with a very soft and sensitive seal. It enables effective discharge of accumulated air from the system while under pressure. The automatic air release valve are lightweight and compact with a 12 mm² orifice enabling release of air at high flow rates not being exposed to obstruction by debris. All operating parts are made of specially selected corrosion-resistant materials.

Air and vacuum valves

AVK air and vacuum valves are designed to discharge air during the filling of the system, and to admit air into the system during system drainage. The dynamic design allows for high velocity air discharge while preventing early closure. The special orifice seat design with a combination of bronze and EPDM rubber ensures long-term maintenance-free operation.





Combination air valves

AVK combination air valves combine the function of automatic air release valves and air and vacuum valves. The automatic air release function releases accumulated air from the system while it is under pressure. The air and vacuum function discharges and admits large volumes of air during the filling or draining of pipelines.

The combination air valves are available in four main types:

- A special design in reinforced nylon (701/40)
- A design combining an automatic air valve with the air and vacuum valve (701/50 and 701/60)
- An underground air valve (701/84)
- A special design in ductile iron (851/20)

The underground air valve unit is designed to save manhole costs. It is suitable for frost protection and for installation under important crossings like roads and buildings where manholes would cause dangerous undermining of the ground.

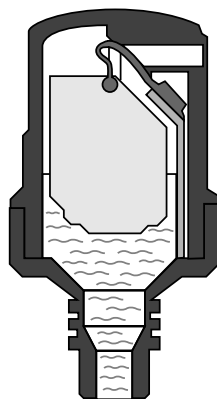

Automatic air valve

For discharge of air liberated from fluid in water mains under pressure

- When air bubbles appear in the valve, the float will drop, allowing air to be released
- When the water rises again, the float will be lifted, and the valve will close

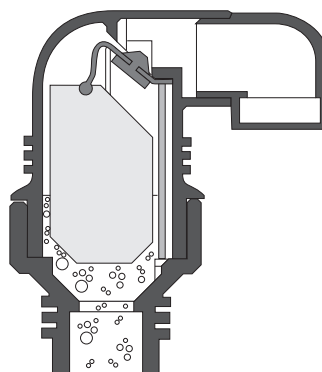

Combination air valve

It combines the function of an automatic air valve with the following:

- When emptying the pipeline, the float will drop completely, allowing large volume air intake through the large orifice
- When refilling the pipeline the water flow will force the air out through the large orifice

AVK CONTROL VALVES DIAPHRAGM OPERATED



Water is a scarce resource that we need to protect. We need to secure water for the next generations and a growing population. Control valves can help reduce water losses and contribute to efficient water supply management by maintaining a certain pressure, flow or level, regardless of changes in the supply network.

The safe choice with 10-year warranty

AVK diaphragm operated control valves are designed according to EN 1074-5 and to provide network stability, accurate regulation, easy maintenance and long durability.

AVK control valves are available in DN 50-300, with reduced and with full bore. Control valves with reduced bore are appropriate for most applications, as the smaller bore often offers more accurate regulation. Control valves with full bore are recommended, if high Kv values are needed, e.g. in front of hydrants.

High quality WRAS approved materials

The body and bonnet are made of ductile iron with fusion bonded GSK approved epoxy coating.

The diaphragm is manufactured by AVK GUMMI and made of drinking water approved EPDM rubber with polyamide reinforcement.

All non-coated internals are of stainless steel AISI 316 as standard and all materials are WRAS approved.

Design features of the valve

- Large diaphragm design (1) secures fast reaction to changes in pressure. Its asymmetric axial position gives less stress near closed position.
- Lifted seat design (2) prevents damage inside the valve body caused by cavitation.
- Parabolic plug design (3) provides precise regulation and stability at low flow. Furthermore, it reduces noise and vibration. See below characteristics, illustrating the performance compared to a standard flat plug design.

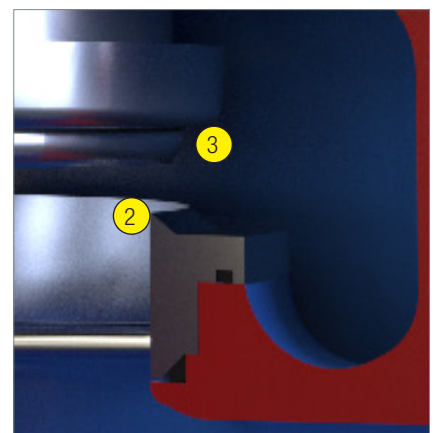
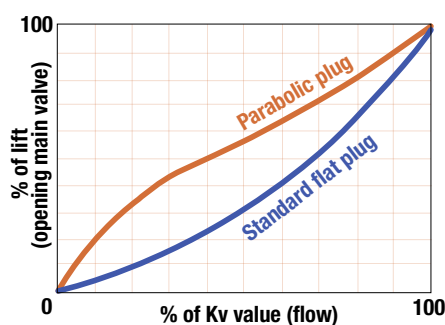
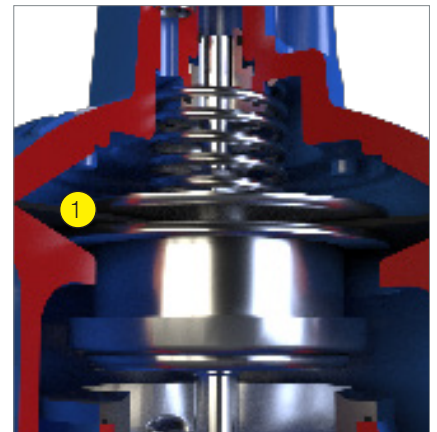

PATENTED PILOT SYSTEM WITH UNIQUE FEATURES



Pressure reducing valve



Pressure sustaining/relief valve

Modular pilot system

The modular design with interchangeable parts offers great flexibility as the pilot system is easily altered to fit other or multiple applications without replacing the valve. The pilot system consists of three main components:

- The distribution block (1) connects the pilot system to the main valve. As a unique feature, it offers independent opening and closing speed, easily adjusted using standard tooling, and giving full control e.g. in situations, where water hammer may occur.
- The filter (2) features high capacity and easy maintenance. When using the optional flush valve it also offers easy access to cleaning, while the valve is in operation.
- The hydraulic control block (3) can be set up for different applications. It features easy hand adjustment of the balanced pilot valve which is capable of very precise settings.

Compact design

The external pipework takes up less space and is less vulnerable to damage during installation compared to many other control valves.

It is designed using components with standard threads offering easy sourcing of replacements as well as easy fitting using standard tools. All metal parts are of stainless steel AISI 316 as standard.

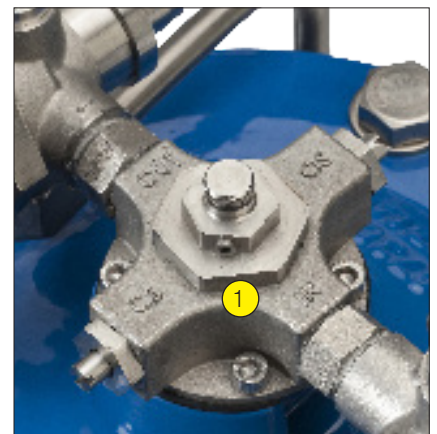

VARIANTS AND CONFIGURATIONS



Pressure reducing and pressure sustaining/relief valves are part of our standard range. On request, we also offer control valve variants such as:

Surge anticipation valve: Automatically protects the pipe system against pressure surges, mainly happening at pump start-up, or in the event of failure.

Altitude valve: Automatically controls the water levels in tanks or reservoirs.

One-way: The altitude pilot senses the water level and opens to refill, once the level drops below set point.

Two-way: Like one-way, but furthermore, the valve opens for returning the flow in case the inlet pressure is lower than the tank/reservoir pressure.

Float level valve: Automatically controls the water levels in tanks or reservoirs.

Modulating: The modulating float is remotely installed and controls the tank/reservoir level at a defined set point. The valve closes tightly at desired level and opens, if filling is needed.

Non-modulating: The non-modulating float keeps the valve closed until the tank/reservoir level reaches the minimum acceptable set point. Then the control valve opens fully to refill, until it reaches the maximum acceptable set point, and the valve closes.

Constant flow valve: Automatically maintains the flow demand, regardless of changes in inlet or outlet pressures.

Solenoid control valve: Automatically either closes or opens the main valve.

Dual solenoid control valve: Automatically controlled by electrical signals. The control valve offers full regulation of pressure, flow and level.

Multi-function and solenoid override

Multi-function control valves, such as a combined pressure reducing and pressure sustaining control valve, are also part of the range. Furthermore, many of the variants are available with solenoid override, where an electric signal either closes or opens the main valve.

Optional configurations

AVK also offers accessories such as pressure gauges and position indicators as well as special configurations e.g. with built-in anti-cavitation trim, lifting lugs and flush valve on the filter.

AVK offers:

Pressure control valves

- Pressure reducing (standard)
- Pressure reducing with check valve
- Pressure reducing with isolating pilot
- Pressure sustaining/relief (standard)
- Surge anticipation

Level control valves

- One-way altitude
- Two-way altitude
- Float level (modulating)
- Float level (non-modulating)

Flow control valves

- Constant flow

Electronic control valves

- Solenoid control, open/close
- Dual solenoid control, regulating

Multi-function control valves

- Pressure reducing / pressure sustaining
- Float level (mod.) / pressure sustaining
- Float level (non-mod.) / pressure sustaining
- One-way altitude / pressure sustaining
- Pressure reducing / constant flow



Select the right control valve

The following conditions should be taken into consideration in order to select the right solution for your application:

- Working conditions
- Maximum flow
- Minimum flow
- Continuous flow
- Maximum inlet pressure
- Minimum inlet pressure
- Wanted outlet pressure
- Pipe size

Strainers and isolating valves

It is highly recommended to install a protection strainer on the inlet side to filter out impurities that could damage the control valve. Isolating valves on each side of the control valve facilitate commissioning and maintenance.

AVK gate valves are available in a vast number of configurations. For isolating control valves, we recommend our standard flanged gate valve with short face-to-face length or the variant prepared for actuator.

Air valves

In many cases it is recommendable to install an air valve at the inlet of the control valve in order to avoid trapped air pockets in the system. Air pockets may cause increased energy consumption and operation costs, pressure loss and increased risk of water hammer.

AVK air valves are available in many variants. For control valve installations, we recommend our combination air valves of ductile iron or reinforced polyamide.

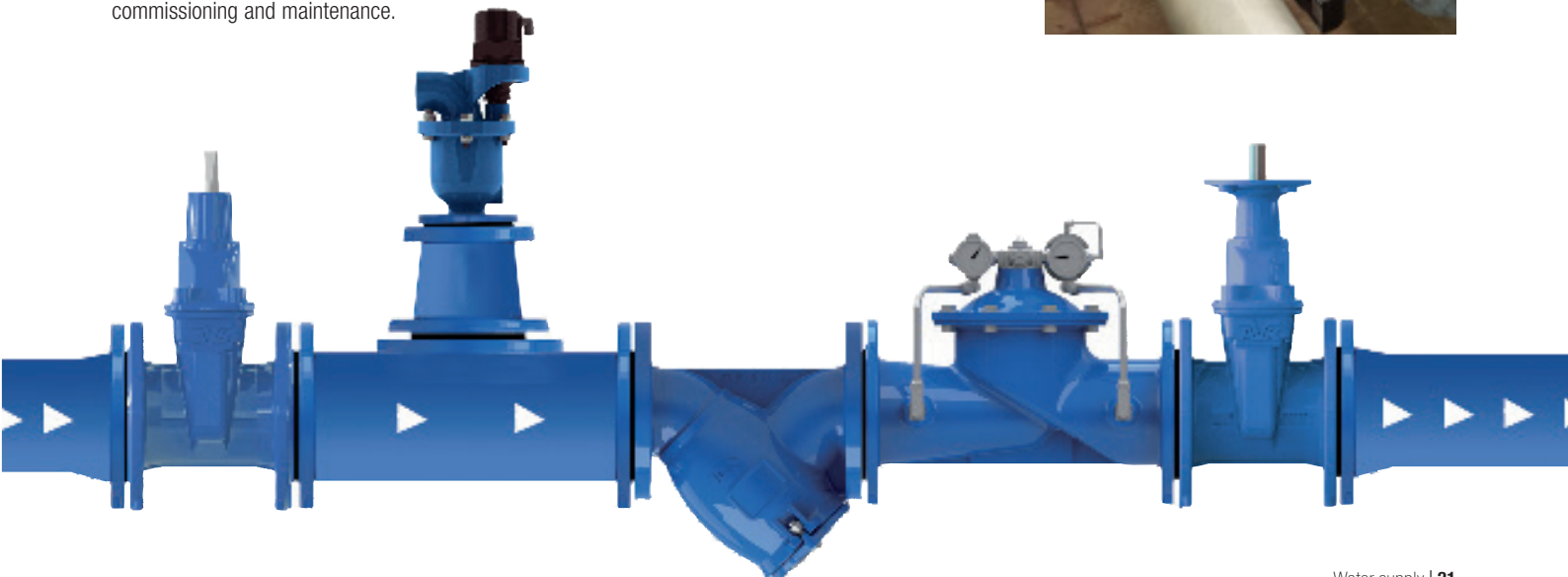

AVK SERVICE CONNECTION VALVES OF DUCTILE IRON, BRASS AND POM



AVK service connection valves are long lasting and maintenance-free. The superior stem and wedge design secure low operating torques as well as a smooth operation of the valve.

Special wedge design

The wedge core is made of dezincification resistant brass vulcanized with drinking water approved EPDM rubber externally. The wedge is shaped with wedge guides, and a patented rubber profile ensures low closing torques.

The wedge rubber and vulcanization is made at AVK GUMMI A/S with the same features and benefits as for main-line gate valves.

POM valves

The bonnet, body and joints of POM (polyoxymethylene) are friction welded ensuring optimum strength. A built-in friction collar prevents overtorque of the valve.

Brass valves

The valves of hot forged dezincification resistant brass are designed with a boltless connection between the body and bonnet. An NBR O-ring is countersunk and compressed when the valve bonnet is screwed onto the body thus ensuring a tight valve.

Ductile iron valves

The design of our ductile iron service connection valves is the same as for the main-line gate valves except for the wedge design. The valves are as standard with internal and external epoxy coating according to DIN 30677-2 and GSK guidelines.

Summary of common features

- Wedge shaped with wedge guides ensures smooth operation
- AVK's wedge rubber has an excellent ability to regain its shape
- AVK's wedge rubber features an excellent bonding, minimum formation of biofilm and a high resistance to water treatment chemicals
- Rolled threads increase the stem's strength
- Thrust collar provides fixation of the stem and low free running torques
- Full bore ensures low head loss
- Low operating torques ensure easy operation

See separate brochure "AVK service connection system" for further details.



Ductile valves in ten variants

AVK offers a comprehensive range of service connection valves of ductile iron. With internal threads, push-in socket ends, screw couplings and PRK couplings as well as combinations with external thread.



Brass valves in four variants

Our service connection valves of hot forged dezincification resistant brass are available with tensile brass screw couplings or PRK couplings and with AVK or T-type bonnet – all in DN 25-50 for 32-63 mm PE pipes.



POM valves in eight variants

Our service connection valves of POM are available with PRK couplings, tensile socket joints and PE ends as well as combinations with external thread. In addition there are options with T-type bonnet.



Wide range of tapping saddles

AVK offers a wide range of tapping saddles. A range that comprises tapping saddles for PE, PVC, ductile iron, cast iron, asbestos cement and steel pipes.

AVK tapping saddles offer easy and fast installation and reliable function and they are maintenance-free and designed to last.

See separate brochure "AVK service connection system" for further details.

AVK SUPA LOCK™ THREADLESS CONNECTION SYSTEM



Connecting valves and fittings with a threaded connection can be time-consuming and often, it leaves part of the thread exposed to the medium and the external environment. Over time this will cause corrosion of the uncoated thread and may even result in a leakage. Supa Lock™ solves this problem.

Full corrosion protection

The patented Supa Lock™ system, provides a 100% corrosion free joint combined with fast and easy assembly with maximum flexibility. Thanks to its simple and ingenious design, Supa Lock™ offers long-term safety with optimum protection against corrosion and leaks and also protection against accidental disassembly of the joint when the pipeline is pressurized.

Valves, tapping saddles and fittings

The wide Supa Lock™ range consists of valves, tapping saddles and fittings in ductile iron with a heavy duty epoxy coating complying with the strict GSK requirements. Furthermore, ball valves and fittings in dezincification resistant brass complying with the EU directive for material used in drinking water installations are part of the range.

Easy two-step assembly
After having lubricated the O-rings, the Supa Lock™ spigot end is pushed into the Supa Lock™ socket end, and the safety retainer is clicked on – and the assembly is done!





Self-locking safety retainer

Supa Lock™ is designed as a tensile joint and withstands pressures up to PN 16 x 1.5. The safety retainer is designed with an edge (1), which makes it self-locking whenever there is pressure in the pipeline. Therefore, no accidental disassembly can take place. The safety retainer has two finger knobs (2) for easy assembly and disassembly.



No rotation of valves and connectors

Free rotation is restricted for the valves and the threaded connectors used for drilling machines to enable effective drilling. Small cast notches placed on the outer rim of the socket end and on the inner rim of the spigot end interlock and prevent rotation.



Heavy duty O-rings provide extra safety

All Supa Lock™ joints are fitted with heavy duty Ø 7 mm O-rings. They provide extra safety when taking into account that a minor permanent deformation of the O-rings is to be expected over the lifetime of the product. Also, when the joint is exposed to bending as a result of ground movements, the large O-rings provide maximum safety.



Corrosion-free access point

For flanged connections in DN 80-400, the wafer type spacer with Supa Lock™ socket connections offers a corrosion protected access point to the pipe. It can replace a tapping and in that way avoid weakening of the pipe.



360° rotation of fittings

The design allows for a 360° rotation of the fittings, which is a unique feature only offered by the Supa Lock™ system. The free rotation of the joint allows the installer to direct the service pipe outlet in any direction from the main pipe, thus avoiding collision with other pipes or obstacles in the trench.

AVK EXTENSION SPINDLES IN A USER FRIENDLY DESIGN



Extension spindles are used for easy access to operation of valves installed below ground. AVK extension spindles are produced on fully automated state-of-the-art production equipment to ensure a uniform quality.

The extension spindles are made of corrosion resistant materials and random samples are torque tested with up to 450 Nm to ensure long service life. The inner tube is press fit to the top spanner and the bottom adaptor to safeguard the galvanization of the tube. The bottom cover protects the valve spindle from impurities and enables it to rotate freely.

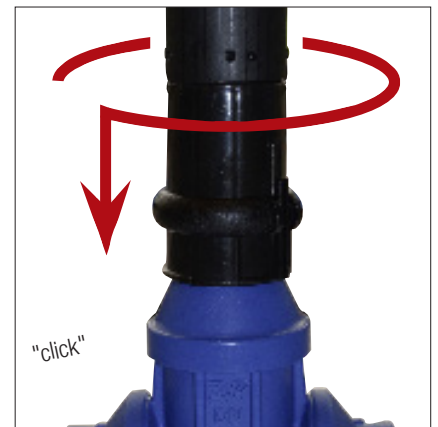



Telescopic and fixed length

- Fixed length version offers the market's easiest shortening of length
- Telescopic version enables height adjustment after installation
- Patented AVK "Safe Click" provides a fast and safe mounting on service connection valves

Fixed length design features easy shortening

Fixed length extension spindles are used when the distance between the valve and the ground surface is known so that adjustment of the length after installation is required to a limited extent or not at all.

The patented AVK design facilitates fast and easy shortening of the extension spindle. The complete adjustment of the length can be done merely by use of a hacksaw.

The extension spindles are available with a pipe cover of 800-1000-1500-2000-3000 mm.

Telescopic design facilitates on-site adjustments

Telescopic extension spindles are used when the distance between the valve and the ground surface is unknown and when an adjustment of the extension spindle is required after installation.

The top adaptor is designed with a defrosting hole and with ears that can be fixed into AVK surface boxes and support tiles. A lock spring prevents the telescopic part from collapsing during installation, as it creates friction inside the inner tube. The blue center sleeve protects against penetration of impurities between the two outer PE pipes.



Expanding bolt design facilitates easy height adjustment on fixed length extension spindles.

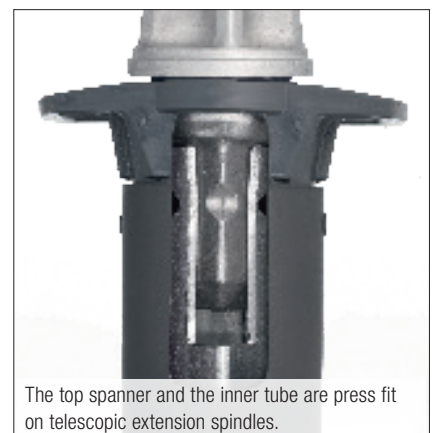

The top spanner and the inner tube are press fit on telescopic extension spindles.

AVK SURFACE BOXES A FULL RANGE

AVK offers a very comprehensive range of surface boxes in various material combinations: synthetic body with synthetic lids, synthetic body with cast iron lids, synthetic body with ductile iron surface plate/lid as well as cast iron body and lid.



Cast iron surface boxes

The ductile iron surface boxes are available in a floating design and a fixed/floating reversible design. The reversible surface box allows for deflection and internal fixation of telescopic extension spindles from both ends.

The fixed surface boxes of grey cast iron are height adjustable using ductile iron distance rings of a height of 10-50 mm.

Floating surface boxes with great flexibility

The internal fixation of telescopic extension spindles enables height adjustment after installation. The deflection ability secures optimal fit on sloped surfaces.

The large chamber provides easy access for mounting and demounting of the extension spindle, and the closed design protects the extension spindle against impurities.

- Square or round surface plate
- Body of polyamide PA-6 or ductile iron
- Surface plate and lid of ductile iron with black primer or blue epoxy coating.



Our Classic range – fixed or height adjustable synthetic surface boxes

Classic surface boxes are DVGW approved and withstand traffic loads according to DIN 1072.

- Fixed height, round or square, with cast iron or synthetic lid
- Height adjustable, round, cast iron lid, optionally with reinforced rim
- Optionally lockable or with locking clip on bolt for installation in places with fast heavy traffic.

It is very easy to install a height adjustable surface box. The 5° angle adjustment enables adaptation to the slope of the road, and the positioning of the top part is flexible by means of the O-ring. With a height adjustable surface box there will be no expensive corrections after installation.

Our Futura range – fixed height synthetic surface boxes

Futura surface boxes feature a slim design with fixed height and a locking clip on the bolt to prevent the lid from being lifted off unintentionally.

- Round or square
- Optionally lockable by a special key
- Black cast iron lid, black synthetic lid or blue synthetic lid.

The synthetic lids are 100 % corrosion-resistant and will look nice even after years of use.

Support tiles for Classic and Futura surface boxes

A support tile increases the support surface in weak soils, secures center location of the extension spindle and prevents telescopic extension spindles from being pushed back.

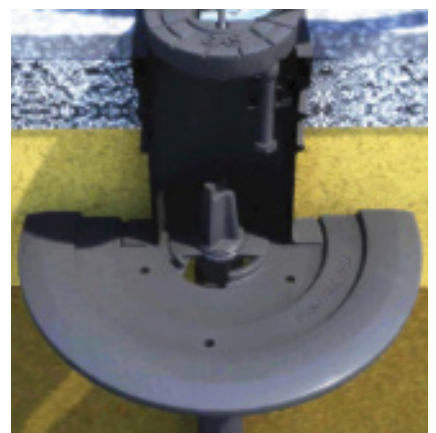

AVK COUPLINGS AND FLANGE ADAPTORS DEDICATED OR UNIVERSAL



AVK combi-flange system

The range comprises tensile combi-flanges for PE/PVC and ductile iron pipes in DN 50-300, non-tensile for PVC and ductile iron pipes in DN 50-600, and non-tensile for steel pipes in DN 50-300.

- The design features a flexible positioning and chamfering of the pipe
- Up to $\pm 3.5^\circ$ deflection of the pipe is possible even in tensile executions
- The pipe will not move inwards during installation which secures a tight connection
- The EPDM rubber sealings are approved for drinking water applications
- Coated according to DIN 30677-2



Supa Maxi™ before tightening



Supa Maxi™ after tightening

Supa Maxi™ universal tensile couplings and flange adaptors

Supa Maxi™ is the latest addition to AVK's range of Supa® couplings. It comprises a complete range of large tolerance universal tensile couplings according to EN 14525 with straight couplings, flange adaptors and end caps in DN 50-400, step couplings and transition couplings in DN 50-300, and gate valves in DN 80-300.

The Supa Maxi™ range sets a new standard with its unique features:

- Fully universal and tensile on all pipe materials
- Patented SupaGrip™ sealing support system with flexible bracket
- PN 16 in all dimensions for water and wastewater (WP -0,9 to 16 bar)
- $\pm 4^\circ$ (8°) angular deflection on each side
- Permanent protection caps protect during handling and installation
- No re-tightening of bolts
- Lifting eye on DN 100-400
- Epoxy coating to DIN 30677-2, GSK approved
- Gasket of EPDM approved for drinking water
- Temperature range -20°C to $+70^\circ\text{C}$



Four additional types complete the range

- Universal non-tensile Supa® straight couplings, step couplings and flange adaptors in DN 40-400
- Dedicated tensile Supa Plus™ straight couplings, flange adaptors, end caps and gate valves for PE and uPVC pipes in DN 40-300
- Fabricated non-tensile straight couplings, step couplings and flange adaptors dedicated for cast iron, ductile iron, steel/uPVC and AC pipes in DN 350-1200
- Fabricated dismantling joints for all pipe materials in DN 50-2200

See separate brochure "AVK couplings and adaptors" for further details.

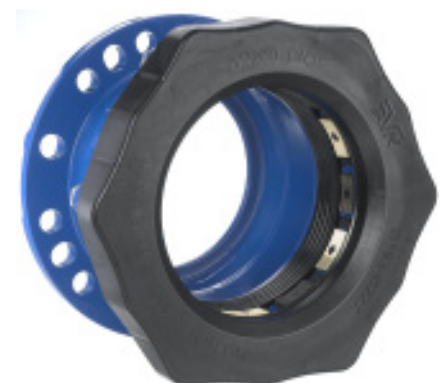

AVK FIRE HYDRANTS ABOVE GROUND AND UNDERGROUND



AVK offers a wide range of fire hydrants for above and underground installation and in a wealth of variants to meet our customers' needs.

Series 84 Multi hydrant

The Multi hydrant is a modern, slim lined hydrant featuring our standard series 84 below ground barrel with all the components known from our existing range. The upper barrel is made of stainless steel for a modern look, and the hydrant head of ductile iron is epoxy coated and has an extra layer of UV resistant polyester coating. The head can be machined for several outlet configurations according to customer specifications such as 2 x Storz B or C, 3rd Storz B or C and an optional Storz A on DN 100. The Multi hydrant is available with or without traffic break-away design and with single shut-off or double shut-off.

Series 09 above ground hydrants

Our series 09 hydrants are 360 degrees rotatable and height adjustable for easy installation. In case of traffic knock down the PE pipe, connecting the upper barrel with the foot bend, will just bend and not break. The hydrants are available of aluminium or ductile iron with manual or automatic drainage, and as top operated or gate valve operated. The automatic drainage hydrant is made in a flush-proof design by means of a membrane drainage valve designed to close when the hydrant is

under pressure, and open when the hydrant is shut-off, allowing the water inside the barrel to be drained. The epoxy coating and an additional topcoat of UV-resistant polyester give a high durability and a strong corrosion protection.





Series 84 above ground hydrants

Our series 84 hydrants are designed with a double shut-off system for safe sealing of the hydrant during maintenance. The flanges connecting the upper and the lower barrel are assembled with special titanium bushes which are the only spare parts to be replaced in case of an accidental traffic knock down.

The upper part is available in a nostalgic design, a modern stainless steel design and in an execution with a lockable cover protecting against unauthorized operation. The lower part is designed with a PUR vulcanised ductile iron disc and vertical seal like the series 35 hydrants.

Series 84 hydrants are as standard with automatic drainage, and optionally with manual drainage. Back-flow protection can be fitted to protect against contamination of the water through the hydrant. The internal enamel and the external GSK approved epoxy coating with an additional topcoat of UV-resistant polyester give a high durability and a strong corrosion protection.



Series 29 underground hydrants

Our series 29/40 hydrants are based on AVK's renowned gate valve design with fully vulcanized wedge, fixed wedge nut and triple safety stem sealing. It is available with bayonet, Storz or NOR coupling.

Our series 29/50 variant is designed with a riser pipe of stainless steel and an AVK extension spindle.

Free flow hydrant

The series 29/78 hydrant is designed without any parts obstructing the medium. The free flow gives a greatly enhanced flow-rate, it makes the hydrants insensitive to hard particles in the water, and offers easy insertion and retrieval of pipe inspection and maintenance equipment.

Series 35 underground hydrants

Our series 35 hydrants seal vertically which gives a low closing torque and makes them easy to operate. The PUR vulcanised plug features a great compression set which ensures that the PUR will regain its shape after having been compressed. The automatic drainage ensures fully emptying of the hydrant after use. Series 35 is available with single shut-off or with double shut-off for easy maintenance, and optionally with internal enamel coating for extra corrosion protection.



FLANGED GATE VALVES



Series 02/20
Flanged gate valve
Face-to-face BS
DN 50-400
PN 10 /16
Ductile iron



Series 02/60
Flanged gate valve
Face-to-face DIN F5
DN 40-500
PN 10/16
Ductile iron

- Options:
- internal enamel
 - PN 25



Series 02/75
Flanged gate valve
Face-to-face DIN F5
Replaceable stem sealing
DN 40-500
PN 10/16
Ductile iron

- Options:
- PN 25



Series 50
Flanged gate valve
Face-to-face GOST
DN 80
PN 10/16
Ductile iron



Series 55/30
Flanged gate valve
DN 450-500-600-800
Face-to-face DIN F5
PN 10/16
Ductile iron
Resilient seated
Replaceable stem sealing

- Options:
- DN 80 By-pass



Series 54
Flanged gate valve
DN 700-800-900
Face-to-face BS
PN 10/16
Ductile iron
Metal seated

- Options:
- DN 80 By-pass



Series 06/30
Flanged gate valve
Face-to-face DIN F4
DN 40-400
PN 10/16
Ductile iron

- Options:
- internal enamel



Series 06
Flanged gate valve
Face-to-face DIN F4
DN 450-800
PN 10/16
Ductile iron
Resilient seated

- Options:
- DN 50 By-pass



Series 06/75
Flanged gate valve
Face-to-face DIN F4
Replaceable stem sealing
DN 50-400
PN 10/16
Ductile iron



Series 15/42
Flanged gate valve
with ISO top flange for
actuator
Face-to-face DIN F4
DN 40-400
PN 10/16
Ductile iron

- Options:
- face-to-face DIN F5



Series 06/35
Flanged gate valve
with pin indicator
Face-to-face DIN F4
DN 50-400
PN 10/16
Ductile iron

- Options:
- face-to-face DIN F5



Series 18/40
Flanged combi-T
DN 80/80 – DN 100/200
PN 10/16
Ductile iron

COMBI-CROSS, GATE VALVES WITH PE, SPIGOT, COUPLING AND SOCKET ENDS



Series 18/70
Combi-cross
with 4 outlets
DN 100-400
PN 10/16
Ductile iron
With ball valves and
DN 100 center outlet

- Options:
- with blind flange on center outlet
 - with 3 outlets



Series 18/00
Combi-cross
flexible design
DN 250-400
PN 10/16
Ductile iron
With ball valves and
DN 100 center outlet

- Options:
- with blind flange on center outlet



Series 36/80
Gate valve with PE ends
DN 65-400
Ductile iron
PE 100 / SDR 11

- Options:
- PE 100 / SDR 17

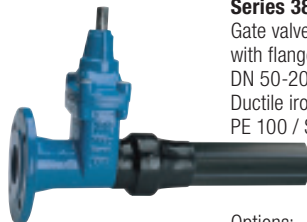

Series 38/80
Gate valve
with flange/PE end
DN 50-200
Ductile iron
PE 100 / SDR 11

- Options:
- PE 100 / SDR 17



Series 12/51
Gate valve
with flange/spigot end for
cast iron pipes
DN 50-300
PN 10/16



Series 32/40
Gate valve
with long spigot ends
for cast iron pipes
DN 80-300
PN 16
Ductile iron

- Options:
- short spigot end
 - for AC pipes



Series 06/38
Gate valve
with grooved ends
DN 50-300
PN 16
Ductile iron



Series 636
Supa Maxi™ gate valve
Universal and tensile for
all pipes
Ductile iron
DN 80-300
PN 16



Series 01/70
Supa Plus™ gate valve
With tensile coupling ends
for PE and uPVC pipes
DN 40-300
PN 16
Ductile iron



Series 01/80
Gate valve
with "Euro" socket ends
for uPVC-pipes
DN 40-400
PN 16
Ductile iron



Series 33/00
Gate valve
with socket ends for cast
iron pipes
DN 80-300
PN 16
Ductile iron
With internal enamel



Series 33/50
Gate valve
with BLS® socket end /
BLS® spigot end
for cast iron pipes
DN 80-300
PN 16
Ductile iron

DOUBLE ECCENTRIC AND CENTRIC BUTTERFLY VALVES



Series 756/100

Butterfly valve
Double eccentric
Double flanged
Integral seat
IP 67 gearbox
DN 200-2800
PN 10/16
Ductile iron

Options:

- stainless steel seat
- PN 25 in DN 200-1200



Series 756/106

Butterfly valve
Double eccentric
Double flanged
Integral seat
IP 68 gearbox
DN 200-2800
PN 10/16
Ductile iron

Options:

- stainless steel seat
- PN 25 in DN 200-1200



Series 756/102

Butterfly valve
Double eccentric
Double flanged
Stainless steel seat
ISO input gearbox
DN 200-2800
PN 10/16
Ductile iron

Options:

- integral seat
- PN 25 in DN 200-1200



Series 75/10

Butterfly valve
Centric with fixed liner
Wafer type
DN 40-1400
PN 10/16
Ductile iron

Options:

- various actuators



Series 75/31

Butterfly valve
Centric with fixed liner
Semi-lug type
DN 50-200
PN 10/16
Ductile iron

Options:

- various actuators



Series 75/41

Butterfly valve
Centric with fixed liner
Full lug type
DN 50-1200
PN 10/16
Ductile iron

Options:

- various actuators



Series 75/20

Butterfly valve
Centric with fixed liner
Double flanged short
DN 50-2000
PN 10/16
Ductile iron

Options:

- various actuators



Series 75/21

Butterfly valve
Centric with fixed liner
Double flanged long
DN 50-1500
PN 10/16
Ductile iron

Options:

- various actuators



Series 820/00

Butterfly valve
Centric with loose liner
Wafer type
DN 25-1000
PN 10/16
Ductile iron

Options:

- various actuators



Series 820/10

Butterfly valve
Centric with loose liner
Lug type
DN 25-600
PN 10/16
Ductile iron

Options:

- various actuators



Series 820/20

Butterfly valve
Centric with loose liner
U-section type
DN 150-1600
PN 10/16
Ductile iron

Options:

- various actuators



Series 813/80

Butterfly valve
Centric with loose liner
Double flanged short
DN 350-600
PN 10/16
Ductile iron

AIR VALVES AND FLOAT VALVES



Series 701/10
Automatic air valve
Threaded BSP 3/4" or 1"
DN 20-25
PN 16
Reinforced polyamide

Options:
• brass base



Series 701/20
Automatic air valve
Threaded BSP 1/2", 3/4",
or 1"
DN 20-32
PN 16
Ductile iron



Series 701/30
Air & vacuum valve
Inlet flange
DN 50-300
PN 16
Ductile iron



Series 701/40
Combination air valve
DN 20, 25 and 50
Threaded BSP 3/4", 1"
or 2"
PN 16
Reinforced polyamide



Series 701/50
Combination air valve
Inlet flange
DN 50-300
PN 16
Grey cast iron/
Reinforced polyamide



Series 701/60
Combination air valve
Inlet flange
DN 50-300
PN 16
Ductile iron



Series 701/84
Underground air valve
installation system
DN 50-100
PN 16
Air valve box of PVC



Series 851/00
Automatic air valve
DN 25
PN 16
Ductile iron



Series 851/20
Combination air valve
DN 50-150
PN 16
Ductile iron



Series 851/20
Cluster air valve
DN 150-250
PN 16
Ductile iron



Series 854
Ball float valve
with lever and float

DN 50-300
PN 16
Ductile iron

Options:
• stainless steel float

CONTROL VALVES, CHECK VALVES AND SERVICE CONNECTION VALVES



Series 859
Control valve
Pressure reducing
DN 50-300
PN 10/16
Ductile iron / AISI 316



Series 859
Control valve
Pressure sustaining
DN 50-300
PN 10/16
Ductile iron / AISI 316



Series 41/61
Swing check valve
Resilient seated
Closed bushings
DN 50-300
PN 10/16
Ductile iron



Series 41/60
Swing check valve
Resilient seated
Free shaft
DN 50-300
PN 10/16
Ductile iron

- Options:
- lever and weight
 - lever and spring



Series 41/36
Swing check valve
Metal seated
Closed bushings
DN 350-600
PN 10/16
Ductile iron

- Options:
- free shaft



Series 41/23
Lever and weight kit
for swing check valve
DN 50-300
Ductile iron



Series 41/32
Spring kit
for swing check valve
DN 50-300



Series 41/1
Guard kit
for swing check valve
DN 80-300



Series 03/00
Service connection valve
with internal BSP thread
DN 25-50
PN 16
Ductile iron

- Options:
- internal enamel



Series 03/30
Service connection valve
with tensile socket ends
for PE pipes
DN 20-50
PN 16
Ductile iron



Series 03/40
Service connection valve
for side tapping with
internal thread / external
thread
DN 25-50
PN 16
Ductile iron



Series 03/65
Service connection valve
with tensile screw
couplings for PE pipes
DN 25-50
PN 16
Ductile iron

SERVICE CONNECTION VALVES



Series 03/85
Service connection valve with tensile screw coupling for PE pipes / external thread
DN 25-32
PN 16
Ductile iron



Series 03/90
Service connection valve with PRK couplings for PE pipes
DN 20-50
PN 16
Ductile iron

Options:
• internal enamel

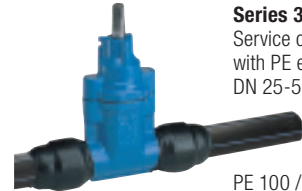

Series 36/8X
Service connection valve with PE ends
DN 25-50

PE 100 / PN 10
Ductile iron

Options:
• PE 100 / PN 16

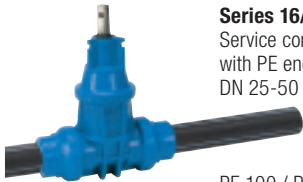

Series 16/80
Service connection valve with PE ends
DN 25-50

PE 100 / PN 16
POM (Polyoxymethylene)

Options:
• T-type bonnet



Series 16/50
Service connection valve with tensile socket ends for PE pipes
DN 25-50
PN 16
POM (Polyoxymethylene)

Options:
• T-type bonnet



Series 16/29
Service connection valve with tensile socket end / external thread
DN 25-50
PN 16
POM (Polyoxymethylene)



Series 16/01
Service connection valve with PRK coupling / external thread
DN 25-50
PN 16
POM (Polyoxymethylene)



Series 16/90
Service connection valve with PRK couplings
DN 25-50
PN 16
POM (Polyoxymethylene)



Series 16/05
Service connection valve with tensile screw couplings for PE pipes
DN 25-50
PN 16
Brass

Options:
• T-type bonnet



Series 16/25
Service connection valve with PRK couplings for PE pipes
DN 25-50
PN 16
Brass

Options:
• T-type bonnet



Series 11/00
Service connection angle valve with external thread on inlet and internal thread on outlet
DN 25-50
PN 16
Ductile iron



Series 11/30
Service connection angle valve with external thread on inlet and tensile socket end for PE pipes on outlet
DN 25-50
PN 16
Ductile iron

SUPA LOCK™ CONNECTION SYSTEM FOR WATER SUPPLY



Series 103/00
Service connection valve with Supa Lock™ spigot/socket end
DN 32
PN 16
Ductile iron

- Options:
- Supa Lock™ spigot end/PRK coupling



Series 343/81
Ball valve with Supa Lock™ spigot end/BSP thread
1"-1 1/2"
DN 32, PN 16
Brass

- Options:
- Supa Lock™ spigot end/PRK coupling
 - Supa Lock™ spigot end/screw coupling
 - with T-type bonnet



Series 100/00
Tapping saddle for PE/PVC pipes
Ø 63-225 mm
DN 32
Ductile iron



Series 100/14
Tapping saddle for iron/steel pipes
Ø 60-223 mm
DN 32
Ductile iron



Series 100/75
Tapping saddle with blade shut-off for iron/steel pipes
Ø 50-360 mm
DN 32
Ductile iron/stainless steel



Series 100/74
Tapping head with blade shut-off
DN 32
Ductile iron



Series 107/31
90° push-in fitting for PE pipes
Ø 32-63 mm
DN 32
Ductile iron

- Options:
- Straight push-in fitting for PE pipes



Series 107/36
Fitting with PE pipe end
Ø 32-40 mm
DN 32
Ductile iron



Series 106/01
Fitting with PRK coupling for PE pipes
Ø 32-40 mm
DN 32
Ductile iron



Series 106/01
Fitting with screw coupling for PE pipes
Ø 32-50 mm
DN 32
Brass

- Options:
- PRK coupling



Series 106/02
Threaded connector for connection to drilling machines
1"-2"
DN 32
Brass

- Options:
- ductile iron
 - Threaded transition connector



Series 109/10
Spacer for flanged connections
DN 80-400
DN 32
Ductile iron

TAPPING SADDLES



Series 10/00
Tapping saddle
for uPVC and PE pipes
DN 50-300
Ductile iron
Lower part in stainless
steel from DN 250



Series 10/14
Tapping saddle
for cast iron, ductile iron
and steel pipes
DN 50-300
Ductile iron



Series 730/2
Universal tapping saddle
for ductile iron, steel and
other metal pipes
DN 50-300
Ductile iron/steel



Series 740
Universal tapping saddle
with shut-off for ductile
iron, steel and other metal
pipes
DN 50-300
Ductile iron/steel



Series 727/10
Tapping saddle
for underpressure drilling
For PE and PVC pipes
DN 80-200



Series 727/09
Tapping saddle SWIC
for underpressure drilling
With integrated cutter
For PE and PVC pipes
DN 50-200



Series 727/19
Tapping saddle SWIC
for underpressure drilling
With integrated cutter
For PVC pipes
DN 80-150



Series 727/08
Tapping saddle SWIC
for underpressure drilling
With integrated cutter
For steel pipes
DN 80-300

SUPA MAXI™, SUPA PLUS™ AND SUPA® COUPLINGS, ADAPTORS AND VALVES



Series 636
Supa Maxi™ gate valve
Universal and tensile for
all pipes
Ductile iron
DN 80-200
PN 16



Series 631
Supa Maxi™ straight
coupling
Universal and tensile
for all pipes
Ductile iron
DN 50-400
PN 16



Series 632
Supa Maxi™ step
coupling
Universal and tensile
for all pipes
Ductile iron
DN 50-300
PN 16



Series 633
Supa Maxi™ flange
adaptor
Universal and tensile
for all pipes
Universal drilling
Ductile iron
DN 40-400
PN 10/16



Series 634
Supa Maxi™ end cap
Universal and tensile
for all pipes
Ductile iron
DN 50-400
PN 16



Series 635
Supa Maxi™ transition
coupling with PN 10 or
PN 16 pipe end
Universal and tensile
for all pipes
Ductile iron
DN 50-300
PN 10/16



Series 01/70
Supa Plus™ gate valve
Tensile for PE and uPVC
pipes
Ductile iron
DN 40-300
PN 16



Series 621/10
Supa Plus™
straight coupling
Tensile for PE and uPVC
pipes
Ductile iron
DN 32-300
PN 16



Series 623/10
Supa Plus™
flange adaptor
Tensile for PE and uPVC
pipes
Universal drilling
Ductile iron
DN 40-300
PN 10/16



Series 624/10
Supa Plus™
end cap
Tensile for PE and uPVC
pipes
Ductile iron
DN 40-300
PN 16



Series 601
Supa® straight coupling
universal for uPVC, AC,
steel, cast iron and ductile
iron pipes
Ductile iron
DN 40-400
PN 16



Series 603
Supa® flange adaptor
universal for uPVC, AC, steel,
cast iron and ductile iron
pipes
Universal drilling
Ductile iron
DN 40-400
PN 10/16

Options:
• Step coupling

COMBI-FLANGES, FABRICATED COUPLINGS & ADAPTORS AND DISMANTLING JOINTS



Series 05
Combi-flange for ductile iron pipes
Tensile
Ductile iron
DN 50-300
PN 10/16



Series 05
Combi-flange for ductile iron pipes
Non-tensile
Ductile iron
DN 50-300
PN 10/16



Series 05
Combi-flange for PE and PVC pipes
Tensile
Ductile iron
DN 50-300
PN 10/16



Series 05
Combi-flange for PVC pipes
Non-tensile
Ductile iron
DN 50-300
PN 10/16



Series 05
Combi-flange for uPVC, steel or ductile iron pipes
Non-tensile
Ductile iron
DN 400-600 (uPVC and ductile)
DN 50-300 (steel)
PN 10/16



Series 05
Combi-flange sealing for uPVC, steel or ductile iron pipes
Non-tensile
SBR rubber
DN 400-600 (uPVC and ductile)
DN 50-300 (steel)



Series 05
Support bush for PE pipes
Suitable for Supa Maxi™, Supa Plus™ and combi-flanges
Stainless steel
DN 50-400
PN 6.3/10/16



Series 258
Fabricated straight coupling for AC, steel, cast iron or ductile iron pipes
Steel
DN 350-2000
PN 8 to 25



Series 259
Fabricated step coupling for AC, steel, cast iron or ductile iron pipes
Steel
DN 350-2000
PN 8 to 25



Series 260
Fabricated coupling and flange adaptor for AC, steel, cast iron and ductile iron pipes
Steel
DN 350-2000
PN 10/16/25



Series 265/30
Fabricated dismantling joint for all pipe materials
Steel
DN 300-1200
PN 10/16/25

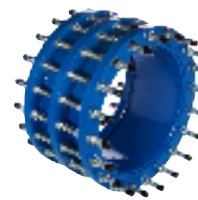

Series 265/50
Fabricated dismantling joint for all pipe materials
With centre flange
Steel
DN 50-2200
PN 10/16/25

SURFACE BOXES FOR SERVICE CONNECTION VALVES AND GATE VALVES



Series 04/10
Fixed surface box
Grey cast iron with blue epoxy

Distance ring/square for fixed surface box

Options:
• floating



Series 04/12
Universal surface box
Reversible design
Ductile iron with blue epoxy



Series 04/43
Fixed surface box
Body of PE
Lid of cast iron



Series 04/007
Floating surface box for telescopic extension spindle
Body of PE
Flange / lid of ductile iron

Options:
• round – black primer
• round – blue epoxy
• square – black primer
• square – blue epoxy



Series 04/008
Floating surface box for telescopic extension spindle
Ductile iron with black primer

Options:
• round or square surface plate
• round or square lid



Series 04/088
Double surface box
Round and square lid with "V" inscription
Ductile iron with black primer



Series 80/30
Surface box H-4055
"Classic"
for underground hydrants
Fixed height
PA+ body

Options:
• oval top
• rectangular top (P)
• cast iron lid
• synthetic lid



Series 80/31
Surface box H-4056
"Classic"
for distribution valves
Fixed height
PA+ body

Options:
• round top
• square top (P)
• cast iron lid
• synthetic lid



Series 80/32
Surface box H-4057
"Classic"
for service connection valves
Fixed height
PA+ body

Options:
• round top
• square top (P)
• cast iron lid
• synthetic lid



Series 80/30
Surface box H-4055V
"Classic"
for underground hydrants
Height adjustable
PA+ body
Cast iron lid

Options:
• reinforced rim



Series 80/31
Surface box H-4056V
"Classic"
for distribution valves
Height adjustable
PA+ body
Cast iron lid

Options:
• reinforced rim



Series 80/32
Surface box H-4057V
"Classic"
for service connection valves
Height adjustable
PA+ body
Cast iron lid

Options:
• reinforced rim
• square top
• hexagonal top

SURFACE BOXES AND ACCESSORIES



Series 80/30
Surface box M-4055
"Futura"
for underground hydrants
Fixed height
PA+ body

- Options:
- oval top
 - rectangular top (P)
 - cast iron lid
 - synthetic lid



Series 80/31
Surface box M-4056
"Futura"
for distribution valves
Fixed height
PA+ body

- Options:
- round top
 - square top (P)
 - cast iron lid
 - synthetic lid



Series 80/32
Surface box M-4057
"Futura"
for service connection valves
Fixed height
PA+ body

- Options:
- round top
 - square top (P)
 - cast iron lid
 - synthetic lid



Series 80/21
Surface box CPH
for service connection valves
Fixed height
Square top
HDPE body
Cast iron lid
PA inscription plates



Series 80/22
Surface box Multi Purpose
for service connection valves
Round top
PA+ body

- Options:
- fixed height
 - height adjustable
 - cast iron lid
 - synthetic lid
 - inscription plate



Series 80/23
Floating surface box
with spindle fixation
for service connection valves
Round top
PA+ body
Epoxy coated cast iron lid



Series 80/41
Surface box PURBRA
for underground hydrants
Fixed height
rectangular top
HDPE body
Cast iron lid
PA inscription plate



Series 80/40
Surface box PERA
for distribution valves
Fixed height
square top
HDPE body
Cast iron lid
PA inscription plate



Series 80/42
Surface box PURDIE
for service connection valves
Fixed height
square top
HDPE body
Cast iron lid
PA inscription plate



Series 80/46
Support tile for surface
boxes for gate valves and
service connection valves
HDPE

- Options:
- large spindle fixation
 - small spindle fixation
 - spindle interface



Series 80/46
Support tile for surface
boxes for underground
hydrants
HDPE



Series 80/46
Top frame for surface
boxes
HDPE

- Suitable in combination
with various surface
boxes:
- for hydrants
 - for distribution valves
 - for service connection
valves

VALVE ACCESSORIES



Series 04/02
Extension spindle for gate valves
Fixed length
DN 40-400



Series 04/04
Extension spindle for gate valves
Telescopic
DN 40-600



Series 04/05
Extension spindle for service connection valves
Fixed length
DN 25-50



Series 04/07
Extension spindle for service connection valves
Telescopic
DN 25-50



Series 04/F
Extension spindle for double eccentric butterfly valves
Telescopic
DN 200-1200



Series 04/15
T-key for gate valves
DN 40-400



Series 04/08/55
Stem caps for gate valves and service connection valves
DN 25-600



Series 08/00
Handwheel for gate valves
DN 50-600
CTC
Grey cast iron

Options:
• CTC



Series 756/08
Handwheel for double eccentric butterfly valves
DN 200-600
Grey cast iron



Series 36
Valve foundation for gate valves with PE ends
DN 25-100
Steel



Series 756/5
Adaptors for connecting gearside to extension rod or wall post indicator and to post indicator. Stem cap for extension rod fitting inside handwheel
DN 200-600
Ductile iron



Series 910
Y-strainer
DN 50-300
Ductile iron

REPAIR CLAMPS AND DUCTILE IRON FITTINGS



Series 729/01
Repair clamp
Single band with support plate
Stainless steel AISI 304 or AISI 316
NBR or EPDM rubber

- Options:
- fingers
 - handgrip



Series 729/02
Repair clamp
Double band with fingers
Stainless steel AISI 304 or AISI 316
NBR or EPDM rubber

- Options:
- support plate
 - handgrip



Series 729/03
Repair clamp
Triple band with support plate
Stainless steel AISI 304 or AISI 316
NBR or EPDM rubber

- Options:
- fingers



Series 729/21
Repair clamp
Single band with BSP thread and support plate
Stainless steel AISI 304 or AISI 316
NBR or EPDM rubber

- Options:
- fingers
 - handgrip



Series 729/32
Repair clamp
Double band with flanged branching and fingers
Stainless steel AISI 304 or AISI 316
NBR or EPDM rubber

- Options:
- support plate
 - handgrip



Series 729/7
Large diameter repair clamp
Internal
600-2000 mm
Stainless steel AISI 304 or AISI 316

- Options:
- width 200 or 400 mm
 - external



Series 712
Flanged bend
Ductile iron

- Options:
- various types



Series 712
Flanged cross
Ductile iron

- Options:
- various types



Series 712
Flanged reducer
Ductile iron

- Options:
- various lengths



Series 712
Reducer flange
Ductile iron



Series 712
Blind flange
Ductile iron

- Options:
- various types



Series 712
Duckfoot bend
Ductile iron

UNDERGROUND FIRE HYDRANTS AND GARDEN FOUNTAIN POSTS



Series 29/40
Underground fire hydrant
with bayonet coupling
DN 100
PN 16
Ductile iron

- Options:
- 3" stortz oupling
 - 3" NOR coupling
 - 4" stortz coupling



Series 29/50
Underground fire hydrant
with bayonet coupling
With AVK extension
spindle and riser pipe in
stainless steel
DN 100
PN 16
Ductile iron



Series 29/78
Underground fire hydrant
Free flow
Single shut-off
DN 80
PN 16
750-1500 mm
Ductile iron



Series 35/31
Underground fire hydrant
Single shut-off
DN 80
PN 16
750-1500 mm
Ductile iron

- Options:
- stainless steel seat



Series 35/85
Underground fire hydrant
Additional ball shut-off
DN 80
PN 16
750-1500 mm
Ductile iron
Stainless steel seat



Series 35/72
Underground fire hydrant
DN 100-125
PN 16
1000-3500 mm
Ductile iron

- Options:
- drilling according to GOST



Series 30
Underground fire hydrant
For mounting on AVK
combi-cross
DN 100
PN 16
Grey cast iron



Series 80/60
Flexdrain
Packing for underground
hydrant
DN 80/100



Series 78/7510
Fountain post
"VICTORIA"
Frost-proof
DN 40
Grey cast iron

- Options:
- outlet for fire hose connection

ABOVE GROUND FIRE HYDRANTS



Series 09/30
Above ground fire hydrant
Type B
DN 80
PN 10
Ductile iron

Options:
• manual or automatic drainage



Series 09/50
Above ground fire hydrant
Type A
DN 100
PN 10
Aluminium

Options:
• manual or automatic drainage



Series 84/05
Above ground fire hydrant
Break-away design with additional ball shut-off
Model P7
DN 80/100
PN16
Ductile iron

Options:
• lateral flange



Series 84/26
Above ground fire hydrant
Drop down pillar
Model P7, Type C
DN 100
PN 16
Ductile iron

Options:
• lateral flange



Series 84/45
Above ground fire hydrant
Break-away design with additional ball shut-off
Model P7
"NOSTALGIA"
DN 80
PN 16
Ductile iron

Options:
• lateral flange
• various coatings



Series 84/72
Above ground fire hydrant
Break-away design with additional ball shut-off
Model P7
DN 80/100
PN 16
Stainless steel

Options:
• lateral flange



Series 84/91
Above ground fire hydrant
Breakable, single shut-off
DN 80/100
PN 10/16
Stainless steel

Options:
• non breakable
• double shut-off

HOW TO FIND FULL DOCUMENTATION



Two paths to our documentation

We have done our utmost to make it easy to find specific product documentation on www.avkvalves.eu.

Choose your area of interest in the upper menu. e.g. "water supply", and get an overview of our products within this area (to the left).

You can also go directly to the "product finder", and pick your choice in the drop down lists. You can choose to fill in all the blanks to find a specific product, or just fill in a few to get an overview of the range.

Or you can choose the quick path, "product series", using the product series numbers stated in this brochure. In the free search field you can state other details such as a specific item number.

Applications:



Product finder:

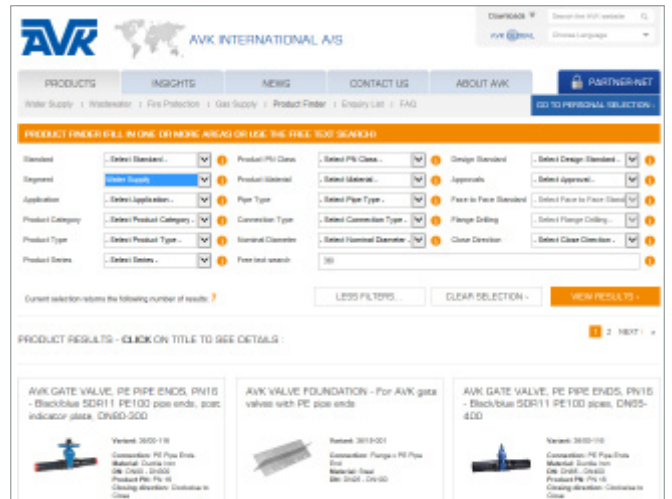
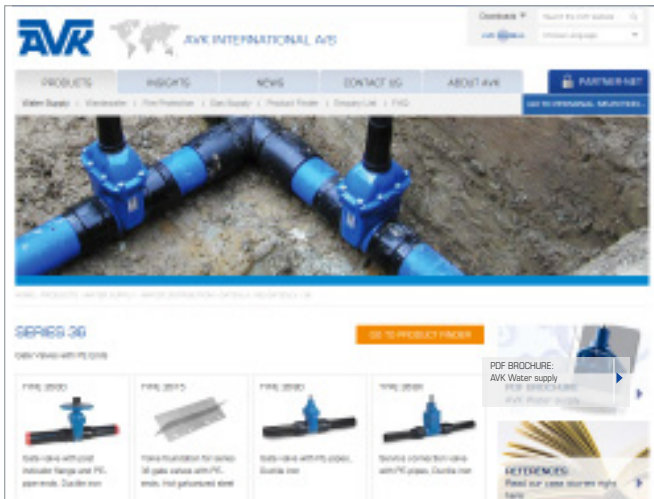
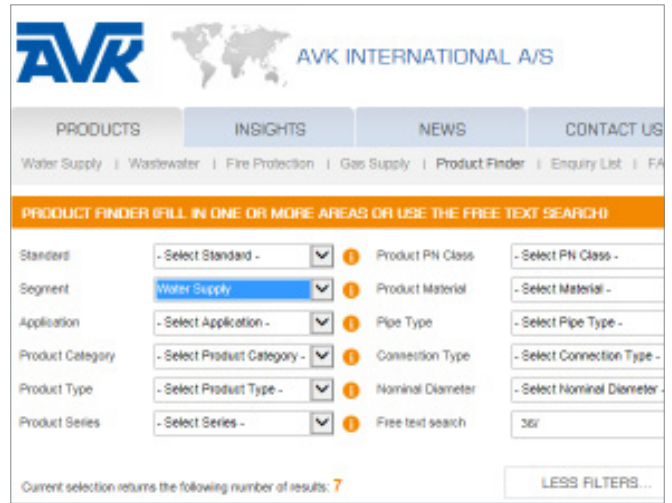

EXPECT SUSTAINABILITY



Given the nature of the business that AVK operates in, we have the possibility and obligation to contribute to the preservation of the environment.

For AVK sustainability and common sense go hand-in-hand. By reducing water waste you do not only save money, you actively help reduce electricity consumption and protect one of our most valuable resources. Our high-quality solutions minimise environmental impacts that excavation, repair or replacement may cause. Thereby we ensure that your business is based on a sustainable foundation that lives up to the requirement of social responsibility and environmental conscience.

Lasting solutions

Sustainability is about creating a sustainable business. Our solutions reduce electricity consumption and CO2 emissions in facilities all over the world. They significantly reduce water wastage simply because we have put a lot of effort into optimising our design. Innovation is a central part of a modern business, and we are dedicated to finding new ways to reduce water wastage and optimise your business.

United Nations Global Compact Principles

The AVK Group realises that a global presence demands high ethical standards. Throughout our organisation and in all our actions we therefore recognise the principles laid out in the United Nations Global Compact document.

International standard for environmental management (ISO 14001)

AVK complies with the internationally accepted ISO 14001 standard, which provides a foundation for eco-management in companies. The AVK Group has outlined a number of strict objectives for its manufacturing companies regarding energy and water consumption, as we are aware that pure water is a scarce resource.

Every AVK employee is motivated to identify areas of improvement in the way we do business to the benefit of the environment. We do not only focus on activities and processes in our manufacturing companies, we also focus on the behaviour and business model of our suppliers.

The AVK Group companies have agreed to a number of standards that our suppliers need to comply with in order to be a certified supplier of the AVK Group. In a world of intensified globalisation, resulting in increasing business relations between countries and cultures, it is vital for AVK to achieve sustainability throughout the supply chain.

We wish to assure our customers that we work with responsible partners who adhere to the same standards as we do. Therefore, we seek partners with high ethical standards. Partners who also comply with international legislation in the field of labour. Thus we naturally also respect all child labour restrictions throughout the entire supply chain and do not accept any discrimination in respect of employment and occupation.

AVK International A/S

Bizonvej 1
Skovby
8464 Galten
Denmark

Tel.: +45 8754 2100
sales@avk.dk
www.avkvalves.eu

2017-05-16
Copyright © AVK Group A/S 2017

Expect... **AVK**

