

# RAVAS GO

SPECIAL PROMOTION LIMITED EDITION



## BENEFITS

- High accuracy: 200g increments
- Exchangeable battery module
- Automatic switch off function
- Pallet truck with quicklift pump
- For check weighing, batching and filling

Top quality

Made in Europe

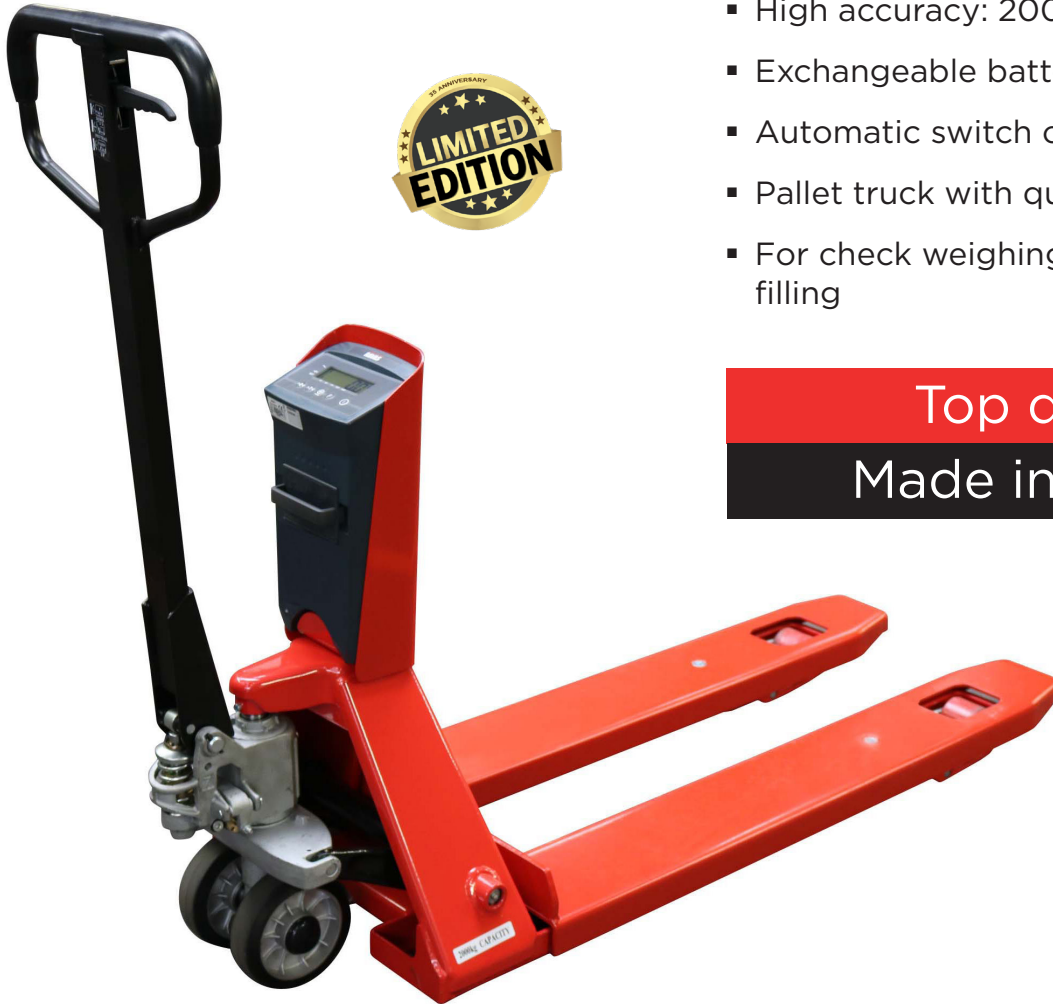

# RAVAS

## FUNCTIONS

- Automatic and manual zero correction
- Gross/net weighing
- Automatic tare over the full scale. Pre-set tare maximum first range (200 kg)
- Totalling with sequence number
- Error messages in display
- Automatic switch-off after 30 minutes of non-use
- Low battery warning in display

## STANDARD SPECIFICATIONS

- Weighing capacity 2,000 kg
- Graduation multirange:  
0 - 200 kg: graduation 0.2 kg  
200 - 500 kg: graduation 0.5 kg  
500 - 2,000 kg: graduation 1 kg
- Max. tolerance 0.1% of the load lifted
- Display LCD, digit height 18 mm
- Keypad 3 function keys, on/off key
- Protection class load cells IP67, indicator IP65
- Battery 12Vdc/1.2Ah, exchangeable; battery charger included
- Battery life 35 hours, low battery indication in display
- Charger 230V/12Vdc - 300 mA
- Charging time approximately 6 hours
- Steering wheels rubber
- Loading wheels polyurethane, tandem
- Pump quick lift
- Own weight 120 kg
- Colour red (RAL 3000), epoxy painted

## DIMENSIONS IN MM

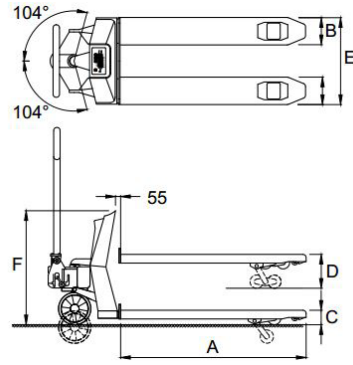

Standard

A	Fork length	1150
B	Fork width	170
C	Minimum fork height	90
	Space underneath fork	22
D	Maximum fork height	180
	Lifting height	90
E	Width over forks	540
F	Height to top indicator	800
	Tolerance +/- 3 mm	



## OPTIONS\*

- Extra exchangeable battery pack

### RAVAS Europe B.V.

Veilingweg 17, 5301 KM Zaltbommel, The Netherlands

T: +31 418 515220 E: salesoffice@ravas.com

WWW.RAVAS.COM

# RAVAS