

## Intelligent technologies

The IQJET does exactly what it's supposed to – print non-stop – with absolute reliability and consistently high quality. Maintenance-free for 5 years. Just switch it on and go. No need for constant cleaning, no start-up problems and no downtime. How did we achieve this? With IQ. Intelligent technologies that do the work for you. Making you more efficient and giving you the confidence that everything is always under control.

### IQ.PRINT

With its unique IQPRINT, LEIBINGER has entirely reimagined inkjet technology. The exceptionally robust, reliable system always ensures the best print quality, short start-up times without the need for cleaning, and maximum availability in day-to-day operation. When not in use, IQPRINT automatically seals the print nozzle 100 % airtight and allows the ink to continue circulating. This prevents the ink from drying and the typical clogging that would otherwise occur. When the IQJET is switched on, it gets back to work immediately. To ensure consistently high print quality regardless of the ambient conditions, IQPRINT permanently regulates ink temperature and viscosity.

### SMART.OS

SMART.OS ensures that operation is easier and faster than ever before. The clearly laid out 10.1" touchscreen display can be adjusted to your requirements as needed. All necessary settings can be made with just a few clicks. In production operation, the IQJET displays key status information in color and visible from a distance. Animated, step-by-step instructions interactively explain the required work steps. This enables anyone, for instance, to replace consumables quickly and easily, even without prior knowledge. It is also incredibly easy to integrate the IQJET into your production line. Several interfaces, including OPC UA, a built-in PLC and a visual wiring check verify whether the inputs and outputs are functioning as they should.

### SMART.EFFICIENCY

SMART.EFFICIENCY, with its unique Eco-Mode feature, automatically seals the ink circuit when not in use. This prevents any solvent from escaping, and evaporated solvent is condensed and fed back into the system. This results in up to 50% less consumption and emissions. The IQJET is also very economical in terms of energy consumption, using only 36 watts on average. Another advantage is the new cartridge system: the XXL cartridges extend the standby and reserve runtimes, are quick and easy to change and mix-up-proof. The cartridges empty to the last drop, so they also save ink. All this, combined with exceptionally high availability, makes the IQJET one of the most efficient printers in the industry.

### SMART.CARE

The IQJET excels with outstanding reliability, efficiency and the lowest possible energy costs – making it the ideal solution for both straightforward and challenging applications. This is also thanks to the new printhead with its precision parts manufactured to the  $\mu$  in LEIBINGER's production facilities, the new housing with IP56 protection and a pressure pump that no longer needs to be replaced. The unique Printhead Refresh feature always ensures the safe and clean removal of ink deposits and a well-maintained printhead – fully automatically. And, when it's finally time for maintenance after 5 long years, you can do it yourself without requiring any special tools or prior knowledge – thanks to interactive step-by-step instructions. So you benefit from better planning and a significant advantage in terms of production time.

## Device descriptions and functional features

### Device variants

- IQJET for the use of dye-based inks
- IQJET for the use of pigmented inks

### Cabinet

- Dust and spray water-protected stainless steel cabinet in accordance with the IP56 standard
- Separate cabinet area for printer control, away from the hydraulic area
- Automatic cabinet emissions monitoring

### Operation

- High-resolution 10.1" TFT color display with capacitive touchscreen
- Intuitive operating concept with simple navigation for fast and safe operation
- Operation using swipe or wipe gestures

- Acoustic prompt and visual display in the event of necessary user interventions
- Simple navigation; all functions are grouped and can be accessed via central icons
- Menu and help texts can be switched to the local language
- Clear homescreen with all production-relevant functions and information:
  - Status screen
  - Large Print start and Print stop buttons
  - Display of ink and solvent levels with range indication in time and number of printouts
  - Real-time (WYSIWYG) display with zoom function for the current print content and display of the job name
  - Display of the total and batch product counter
  - Display of the product speed, selectable in pieces or meters per minute with display of the maximum speed
  - Quick access to the job using favorites
  - Change of the print content during operation
  - Display of the history of all printer messages
- Automatic switchover to remote screen after freely selectable period of time. Color status screen of the printer and display of the product counter
- Operator assistants with true-to-life, interactive step-by-step display of all relevant activities
- Explorer with direct content preview for selecting jobs, fonts and graphics and corresponding import/export function
- Export function for log files and backups
- Selection of jobs and print content via connectable codescanner (1D or 2D)
- Transfer of print content and selection of jobs from an external system via interfaces
- Print job editor with graphic user interface to generate and change jobs with fixed or variable content:
  - Creation of new jobs during operation
  - Editing functions by drag-and-drop and copy-and-paste; marking of individual or multiple objects
  - Real view of the created print job with millimeter scaling
  - Automatic calculation of the required ink drop count per printout during job creation
  - Automatic calculation of the maximum print speed during job creation in the job editor
  - Freely-definable quick input fields for input of batch-relevant print data upon production start
  - Test print function to trigger a single printout of the current job for control or setup activities
  - Saving of any number of jobs
- Graphics editor for creating printable logos and graphics using tools for creating shapes and lines
- Font generator to create and adapt specific fonts with the assistance of tools for creating shapes and lines
- User management with freely configurable, user-specific authorizations
- Freely configurable Autostart function for automatically starting a defined job after switching on
- Shop function to order consumables via the printer menu
- Backup function to save and restore all printer settings and jobs
- Central data administration for saving jobs locally and to download jobs from connected data carriers
- Production log with detailed information on production time and quantity for each job
- FIFO slide tab for intermediate storage of print signals to prevent loss of printouts

### Consumable replacement

- Cartridge system for inks and solvents
- Mix-up-proof replacement of ink and solvent cartridges
- Automatic check of the consumable type to make sure it is correct and warning to the user if it has been filled incorrectly
- Easy insertion of the cartridges with tip-and-click mechanism
- Complete draining of the cartridges
- Long reserve lifespans of up to several days after sending the refill message for high availability and uninterrupted operation of the production machine (the reserve lifespan depends on the application)
- Cartridges can be replaced during printing operation
- Interactive step-by-step instructions for replacing the cartridges

### Availability/print quality

- Automatic nozzle sealing system hermetically seals the ink circuit, preventing ink buildup and nozzle clogging when the printer is shut off
- The ink is prevented from drying out in the suction tube thanks to the hermetically sealed circuit
- Fail-safe shut-down with automatic nozzle sealing system and safe shut-down of the printer
- Automatic circulation of the ink to prevent clogs in the ink circuit, even when the printer is shut off
- Printhead-Refresh function to remove impurities on the printhead; no need for manual printhead cleaning
- Active ink temperature control for a constant printhead temperature and font quality under fluctuating ambient conditions
- Automatic control of the ink viscosity for optimum drop creation, regardless of ambient influences
- Automatic modulation control for setting the optimum drop shape
- Dynamic control of the loading time point for precise drop positioning
- Automatic monitoring of the position of the jet of ink
- Dynamic compensation for the drop flight time for a constant position of the printout with different production speeds
- Automatic monitoring of the maximum print speed
- Monitoring the product distance with adjustable tolerance
- Monitoring print signal, product length and product jam, each with adjustable tolerance
- Adjustable print signal interference filter with monitoring and adjustable threshold value
- Automatic adjustment of the print width or selectable print stop if the speed is exceeded
- Monitoring the print length overlap to prevent print start while printing
- Measuring and displaying the printer availability and the usage level
- Automatic monitoring of the fan function

- Long-term shutdown without additional effort, without nozzle or ink circuit clogging
- Freely programmable, automatic interval ink circulation to prevent ink deposits
- Integrated, wear-free stirring systems to retain the pigment dispersion (**only for printer variants for pigmented inks**)

## Printing functions

- 30 different pre-installed fonts, selectable from 5-dot to 48-dot
- Fonts can be added
- Country-specific character sets
- 30 country-specific keyboards
- Selectable proportional function for all fonts
- Freely selectable print width and print height
- Variable character spacing
- Print content can be printed forwards, backwards, mirrored, normal or upside-down or in any freely selectable combination of these alignments
- Alternating legible typeset printout, reverse
- Inversion of the print content to print the background instead of the content
- Adjustable increments for boldface and contrast function
- Three available print modes with different levels of quality

## Print content

- Texts, symbols, numbers, special characters
- Fixed text or variable data in all available fonts
- Common barcodes, 2D codes, data matrix codes, QR codes with adjustable sizes and adjustable height/width ratio
- Graphics and logos created in the graphics editor or imported
- Print content like codes, clear text, date, counters and graphics are freely positionable and combinable in a printout
- Printing of meter markings or other continuous markings with freely selectable distance
- Counter with freely programmable increments, counting direction, counter increments, number of digits, start/end values as well as display parameters
- Counter can be reset during production; new start values can be set during production
- All date and time formats, best before date formats, Julian calendar, days of the week with internal calendar and clock function incl. automatic daylight saving time changeover
- Freely selectable replacements for date and time content, counter and other elements
- Adjustable date change offset
- Shift codes with freely selectable start times and content

## Print control

- Freely adjustable distance from product detection until print begin (print delay) in mm
- Freely adjustable distance from print begin of a printout to print begin of the next printout in mm
- Freely adjustable number of automatic print repetitions
- Distance-controlled job lists for automatic interlinking of multiple print jobs in freely-defined mm increments
- Print start signal-controlled job lists for sequential processing of different jobs with job change after freely selectable quantities
- Selectable print stop behavior between print cancelation and print completion
- Automatic print stop and/or output of a signal after reaching a preselected quantity

## Integration

- Integrated mini PLC to link to input signals without additional control hardware
- Signal configurator for freely selectable assignment of functions and events to selectable input and output signals with freely assignable pin assignments.
- Configurable output signals, selection of signal duration, signal type (high active or open collector) and inversion
- Configurable input signals, selection of signal durations and signal form (high active or low active)
- Connection option for an incremental encoder to synchronize the print output with the production speed or product movement
- Internal clock generator with adjustable speed for applications without use of an incremental encoder
- Function for direction detection of production movement with compensation of reverse movements (reverse compensation)
- Automatic print direction switching for traversing applications with printing in both directions of movement
- Automatic printer signal generation when changing the direction of movement
- Connection option for sensors for detecting the product speed
- Function to measure the product speed via two sensors instead of an incremental encoder
- Connection option for various product detection sensors to control the printout positioning
- Connection option for an enable sensor for endless printing, with actuated sensor
- Connection option for a sensor to monitor the product detection
- Connection option for a three-color status light
- Variable signal inputs with debounce and interference filter function
- External selection of the job, up to 1024 predefined print contents are selected via external control signals (e.g. from the PLC) at up to 10 inputs and switched during print operation
- Signal monitor for clear display of all input and output signals with signal simulation function
- Host-client function to control and operate multiple printers in a system via a central printer
- Saving different connection and integration settings for various production machines for variable use of a printer in different production lines
- Remote switch-on function via an external signal
- All electrical connections are made with connectors
- No individual wiring on connection terminals required

## Connectivity

- All common data interfaces are available
- OPC UA protocol – ready for IOT, Industry 4.0
- Printer can be programmed via the Leibinger LJ protocol and controlled via a higher-level system in different depths:
  - Level 1: Create the layout on the printer. Delivery of variable data elements from an external source via interface
  - Level 2: Layout including all print data is defined/sent via script language commands from an external location
  - Level 3: External control of all printer functions via interface. No operator interaction on the printer
- Printing variable data set-by-set
- Connection to Leibinger Connect (optional); Leibinger Connect is a cloud-based platform for smart networking of Leibinger marking systems and for value-added use of the available data.

## Mechanical integration

- Low device footprint thanks to its compact design
- No additional space requirements on the sides or above thanks to the front-loading cartridge system
- Flexible umbilical with tight installation radii
- Robust umbilical with extruded line and extruded connection fittings. Even for connections with traversing printhead
- Shorter, cylinder-shaped printhead with metal chassis
- Stainless steel printhead cover with safety switch
- Printhead can be mounted in all directions (360°); can also print from below
- Simple assembly and rotation of the printhead with round clamp printhead holder (accessory)

## Commissioning

- Interactive step-by-step instructions for initial commissioning
- Assistant-guided, automatic initial filling process
- Test printout for setting the rotary encoder

## Sustainability

- No solvent consumption during production pauses due to automatic nozzle sealing system after a freely adjustable duration of production pause
- Solvent recovery to reduce solvent consumption and cut emissions
- No regular rinse cycles with high solvent consumption necessary
- Low solvent consumption of under 3 ml/h
- One liter of ink is sufficient for up to 160,000,000 printable characters with dye-based inks and up to 117,000,000 printable characters with pigmented inks
- Empty cartridges can be disposed of with regular waste
- Low energy consumption thanks to intelligent energy management
- Low-wear membrane pump with demand-controlled on-time

## Maintenance / service

- 5 years maintenance-free (with dye-based standard inks)
- Do-it-yourself maintenance with up to 20,000 operating hours each time (with dye-based standard inks)
- Interactive step-by-step instructions for do-it-yourself maintenance
- Early maintenance warnings
- On-screen maintenance log with automatic entries
- It is possible to use the printer even after exceeding the maintenance interval (no printer shut-off)
- No planned replacement of the main pump over the entire printer service life
- Remote service with Leibinger Connect for immediate online help and support for anything involving marking tasks
- Display of all operationally-relevant values and settings for a quick overview with diagnostic data export function
- Local Leibinger support

## Options

- Different nozzles available for different dot sizes
- Umbilicals in various lengths
- LAN interface module for connecting the printer to Leibinger Connect via the customer's LAN
- LTE interface module for connecting the printer to Leibinger Connect via the mobile data network
- Integrated mini UPS for bridging power outages of up to a few seconds and for safe, automatic shut-down during longer power outages
- Active ventilation of the printhead to increase the service life in demanding industrial environments. Overpressure generated in the printhead by a pump prevents the penetration of dust and dirt.
- Active printhead ventilation with air drying for use in environments with high, condensing humidity
- Dust-proof stainless steel cabinet protected against strong jets of sprayed water in accordance with the IP66 standard (no external compressed air required)
- If not required, you can deselect the Printhead-Refresh function when ordering

## Consumables

- Pigmented high-contrast inks in various colors (**only for printer variants for pigmented inks**)
- Dye-based inks in various colors
- Inks with different solvent systems, such as MEK, MEK-free and ethanol
- Security inks
- Color-changing inks
- Adhesive inks
- Alcohol and sterilization-resistant inks
- UV-curable inks
- Heat-curable inks
- Fast-drying inks, drying times < 1 second
- Inks for food packaging
- Inks for direct contact with food
- Customer-specific special inks

## Printable materials and surfaces (examples)

- All types of metals
- Nearly all types of plastic
- Films
- Extruded products
- Mineral materials
- Textiles, leather
- Smooth, non-absorbent surfaces
- Porous, absorbent surfaces
- Glass, ceramic
- Synthetic rubber, natural rubber, latex
- Injection-molded parts
- Wood, paper and cardboard
- Flat, rough, concave, convex, relief, stepped and furrowed surfaces

## Overview of technical data

### Printer and printhead

Voltage range	100–240 V AC
Mains frequency	50–60 Hz
Current consumption	max. 0.68 A (at 100 V AC); max. 0.35 A (at 240 V AC)
Power consumption in printing operation	usually 36 W
Bridging time during a power outage with an integrated mini UPS (optional)	A few seconds
Compressed air supply	Not required
Interval operation	Max. 20 times can be defined
Display	10.1" color display; 1,280x800; multi-touch; capacitive (PCAP)
Umbilical length	3 m, 6 m (optional)
Umbilical bend radius	> 45 mm (fixed routing), > 180 mm (movable routing)
Umbilical type	Extruded
Umbilical printhead connection	Straight, designed with an extruded fitting
Printhead type	SK 7
Nozzle sealing system	Automatic
Ink temperature regulation in the printhead	Tube heating
Printhead nozzle size	70 µm, 60 µm (optional), 50 µm (optional, not available with printer variants for pigmented inks)
Printhead material	Chassis: Aluminum, printhead cover: V2A
Printhead weight	approx. 0.7 kg (without umbilical)
Printer cabinet material	V2A
Printer cabinet weight	23.15 kg (empty, incl. printhead with 3 m umbilical)
Protection type	IP56, IP66 (optional) To maintain the protection type, all unassigned connections on the printer must be closed with the protective caps.

### Ambient conditions

Temperature range	+5 °C...+45 °C
Relative humidity	max. 90% (non-condensing)

### Reservoir tank volume / reserve lifespans

Ink reservoir tank	1,290 ml
Solvent reservoir tank	1,400 ml
Ink reserve lifespans	> 50 hours (typical application with 400 prints/min and 60 µm nozzle)
Solvent reserve lifespan	> 50 hours (at room temperature)

### Range / consumption data

Ink consumption, number of characters per cartridge (950 ml)	94 million characters (with 7-dot font and 60 µm nozzle)
Solvent consumption in printer operation (ethanol)	< 2 ml/h (at 20 °C and 60 µm nozzle)
Solvent consumption in printer operation (MEK)	2.7 ml/h (at 20 °C and 60 µm nozzle)
Solvent consumption during production pauses	0 ml/h (with Eco-Mode active)

### Refill system

Refill system	Mix-up-proof cartridges
Ink cartridge fill quantity (dye-based ink)	950 ml
Ink cartridge fill quantity (pigmented ink)	850 ml
Solvent cartridge fill quantity	950 ml

## Inks

Pigmented inks	Various pigmented inks in different colors ( <b>only for printer variants for pigmented inks</b> )
Dye-based inks	Various dye-based inks in various colors
Ink base	MEK, MEK-free, acetone, ethanol
Ink properties	fast-drying inks (< 1 s), security, color-changing, adhesive, fluorescent, alcohol and sterilization-resistant, halogen-free inks, food packaging inks, customer-specific special ink

## Printing performance data

Min. print height (single-line)	1.3 mm (at 5 drops; 3 mm distance from the printhead to the product; print height 55%)
Max. print height	13.1 mm (at 48 drops; 15 mm distance from the printhead to the product; print height 85%)
Max. print speed	2,400 printouts/min
Max. speed	413 m/min (at 5x5 and 60 µm nozzle) 275 m/min (at 5x5 and 70 µm nozzle) All information is based on a single line of text, 10 characters/inch and drop distance 0.43 mm.
Max. printing rate	3,200 characters/s (at 5x5 and 60 µm nozzle) 2,100 characters/s (at 5x5 and 70 µm nozzle)
Max. number of lines	8 lines (at 5x5) 6 lines (at 7x5)
Spacing between printhead and product	3 mm up to 30 mm (depending on the font mode)
Max. vertical resolution (stroke height)	48 drops

## Printing functions

Fonts	All fonts can be combined as desired in the lettering Fonts from 5-dot to 48-dot 3dot_tower_cable, 3dot_tower_highspeed, 5dot, 5dotbaseline_offset, 5dot_tower, 5dot_tower_highspeed, 6dot, 7dot, 7dot_baseline_offset, 9dot, 9dot_baseline_offset, 9dot_baseline_offset_bold, 11dot, 11dot_MS Gothic, 12dot, 12dot_baseline_offset, 13dot, 13dot_MS Gothic, 14dot, 14dot_baseline_offset, 16dot, 16dot_baseline_offset_BERN, 18dot, 24dot_BERN, 24dot_baseline_offset, 24dot_baseline_offset_BERN, 32dot, 48dot Upper case and lower case letters, umlauts, special characters, Asian, Cyrillic, Arabic and other characters Latin, Arabic, Farsi, Hebrew, Chinese Traditional, Chinese Simplified, Thai, Korean, Kanji, Katakana, Hiragana (limited character set), Cyrillic, Vietnamese Tower print Max. 20 user-defined fonts
Font mode	Multi-level contrast and boldface Variable character spacing Contents mirror-inverted/vertical overprint/backwards Alternating legible contents (alternating 180° rotation) Contents inverted
Job	Max. 48 objects per job Max. 32 counters per job Max. 48 shift times per object Max. 1,024 jobs per job list
Possible print job content (objects)	<b>Text:</b> Fixed text (changeable during production via the prompt field function); dynamic text via interface or data base <b>Counter:</b> Counting direction can be changed; counting increments can be variably set; replacements possible; counter readings can be adjusted during production <b>Date and time:</b> Automatic date; minimum expiration date; calendar weeks; Julian calendar; replacements possible <b>Graphic:</b> Pre-made graphics available on the printer; create and import new graphics externally; create new graphics on the printer <b>Shift code:</b> Replacements possible <b>Barcode:</b> All common barcode formats are supported; height and width ratio can be adjusted <b>Code types:</b> Code 39, Interleaved 2 of 5, Code 128b, Code 128c, Pharmacode, PZN, EAN-8, EAN-13, UPC-A, UPC-E, POSTNET, USPS4CB, GS1-128 <b>2D code:</b> All common 2D formats are supported; code size can be adjusted <b>Code types:</b> Data Matrix square, Data Matrix rectangle, QR Code, GS1-Data Matrix Square, GS1-Data Matrix rectangle, GS1-QR Code, PPN-Data Matrix, PPN-Data Matrix rectangle

## Print control

Speed and position detection	Rotary encoder, 2-sensor measurement, fixed set speed (max. 5000 m/min)
Print delay	Adjustable via job properties
Print repetition distance	Adjustable via job properties
Max. print repetition number	Endless
Max. number of products between product detection sensor and printout	Max. 128 products

## Inputs

Debounce time	20 $\mu$ s
max. holdoff	2 s

## Outputs

Max. hold time	6.5 s
----------------	-------

## Interfaces

Ethernet	For general data exchange Version: M12D, 4-pin, socket, cable: Cat 5, max. 100 MHz
Ethernet (cloud)	Only for connecting to LEIBINGER Connect Version: M12D, 4-pin, socket, cable: Cat 5, max. 100 MHz
USB	For general data exchange Version: Type A, USB 2.0, recommended file systems: FAT32, ext3, ext4
USB (cloud)	For connecting an LTE stick for connecting to LEIBINGER Connect. Version: Type A, USB 2.0
Rotary encoder (X1)	For connecting incremental encoders Version: M12, socket, 8-pin, TTL, HTL, RS-422, Differential HTL
Serial interface (X2)	RS232 Version: SUB-D, 9-pin, socket
Digital outputs (X3)	8 freely configurable outputs Version: SUB-D, 15-pin, socket
Digital inputs (X4)	10 inputs for job selection 8 freely configurable inputs, one preset input (Power On) Version: SUB-D, 25-pin, pin
Print start (PrintGo) (X5)	For connecting to the product detection sensor and, if needed, also the print release sensor or monitoring sensor Version: M12, 5-pin, socket, NPN / PNP 24V

## Tests

Test symbols	CE, UKCA
--------------	----------

## Maintenance

Maintenance interval	Dye-based standard inks: 60 months or 20,000 operating hours Soft pigmented inks: 18 months or 6,000 operating hours Heavy pigmented inks: 12 months or 4,000 operating hours
Maintenance system	DIY maintenance concept, assistant-guided exchange of components by the operator possible



## Dimensions

### Printer cabinet dimensions

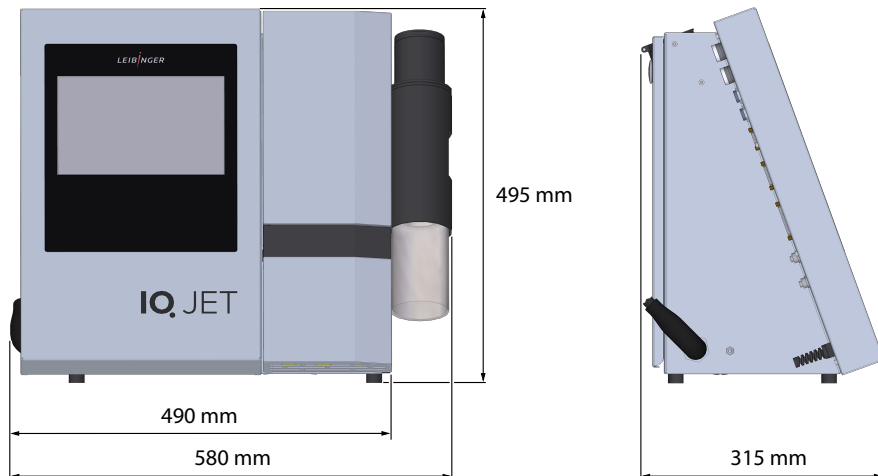

Fig. 1: Dimensions when front doors are closed

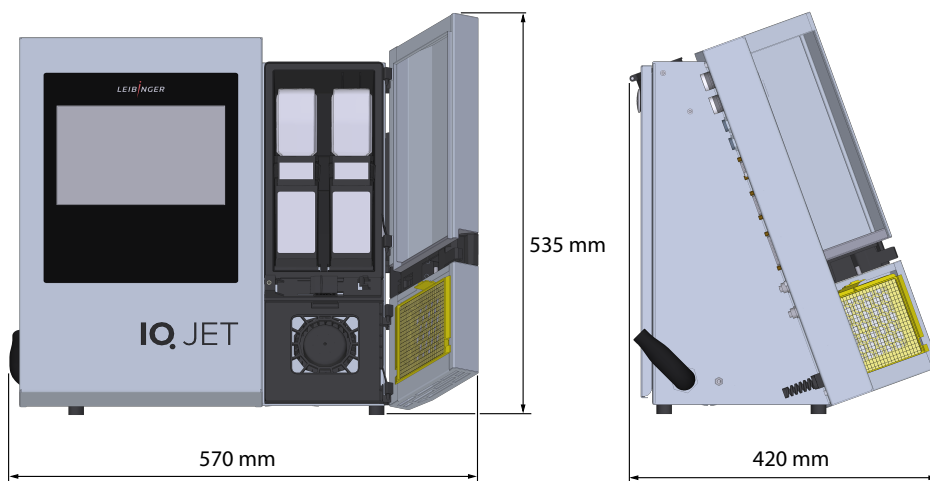

Fig. 2: Dimensions when front doors are open

### Printhead dimensions

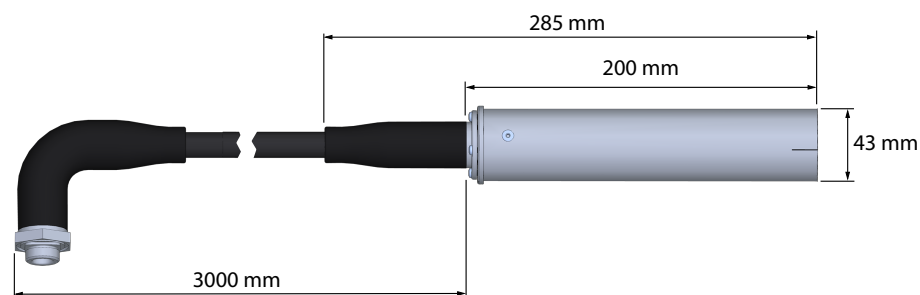

Fig. 3: SK7 printhead dimensions (standard with 3 m umbilical)

#### Global headquarters EMEA and APAC Competence Center

Paul Leibinger GmbH & Co. KG  
Daimlerstr. 14  
78532 Tuttlingen  
Germany

Phone: +49 74 61 / 92 86-0  
Fax: +49 74 61 / 92 86-199  
Email: [info@leibinger-group.com](mailto:info@leibinger-group.com)



#### Competence Center North and South America

Paul Leibinger Inc.  
2702 Buell Dr #2  
East Troy, WI 53120  
United States

Phone: +01 262-642-4033  
Fax: +01 262-642-4030  
Email: [cs@leibingerusa.com](mailto:cs@leibingerusa.com)



#### Competence Center China

Leibinger China Ltd.  
No. 10, Keji 1st Road  
Zhuhai City  
High-Tech Zone  
China

Phone: +86 (0) 756-8866803  
Email: [cs-china@leibinger-group.com](mailto:cs-china@leibinger-group.com)

