

Technical Documentation

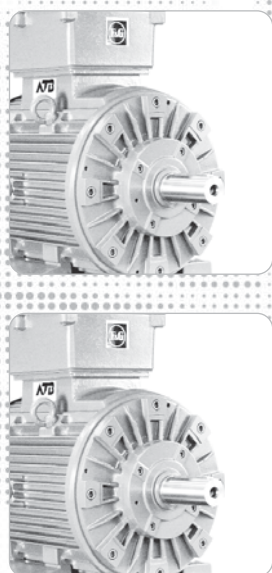

Three-Phase Explosion Proof Motors Flameproof Enclosure

under license of



Vision



We get your ideas moving. We not only manufacture motors, we turn the ambitious ideas of our customers into modern, innovative and reliable products, which point the way to the future. Our blend of reliability, creativity and flexibility ensures that our customers reach their goals.

Business Units



Industrial motors



ATB Thien drive systems



Motors for house and garden appliances

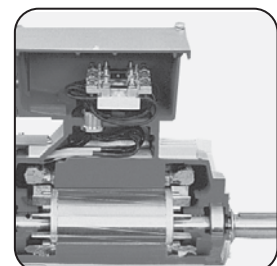

Explosion-proof electrical motors

Index

1

General Specifications		I
Construction Type	Versions, Special-Purpose Motors	II
Electrical Version		III
Operating Characteristics		IV
Operating Data	Low-Voltage Motors	V
	High-Voltage Motors	VI
Dimensions		VII
Spare Parts		VIII
Conversions and Formulae		IX
Point of Contact		X

Content

2

General Specifications

Certificates and standards	4
Explosion protection	
– Explosion protection types of electrical machines	6
– Explosion protection and categories of electrical machines	8
Type code	12

Construction Types

Mountings	13
Materials, plates and labeling	14
Installation at normal, high and low temperatures	15
Protection types, paintwork	16
Terminal boxes	17
Direct cable connection implementation	19
Bearings	20
– Bearing arrangement	21
– Bearing arrangement in standard motors	22
– Permissible radial loading, deep groove ball bearing	23
– Permissible axial loading, deep groove ball bearing	24
– Permissible radial loading, cylindrical roller bearing	25
– Rotor weights	26
– Lubrication, bearing monitoring	27
– Bearing eddy currents, insulated bearings, mechanical limit speeds	28
– Shaft ends, balancing, vibration amplitude	29
– Operating noise levels, cooling air quantity	30
Special-purpose motors	
– Low-noise motors, noise class 1–3	31
– Water-cooled motors, noise class 4	32
– On-deck installation with shipping classification	34
– Flexi Mount motor	36
– Built-on and build-in equipment, tacho generator	37
– Built-on and build-in equipment, reverse-running lock, direct gearing mounting	38
– Brake motors with integral brake	39
– Brake motors with external brake	40
– Three-phase asynchronous motors with integrated frequency inverter (Compact drives)	41
– High-voltage motors	44

Electrical Implementation

Electrical design for motors up to 690 V	45
Safety devices, heating elements	46
Diagram of connections	48

Operating Characteristics

Motor operating characteristics to 690 V	49
Permissible start up times for air-cooled motors without brake, temperature class T4, protection through PTC thermistor temperature sensor	50
High-Efficiency motors	52
Frequency inverter operation	54

Operating Data, Low-Voltage Motors

Mains operation and inverter operation, Standard output 50 Hz	
– ns = 3000 rpm, 2p = 2	58
– ns = 1500 rpm, 2p = 4	60
– ns = 1000 rpm, 2p = 6	62
– ns = 750 rpm, 2p = 8	64
Mains operation, Partial load data, 50 Hz	
Efficiency, power factor	66
Standard output, 60 Hz	
– ns = 3600 rpm, 2p = 2	68
– ns = 1800 rpm, 2p = 4	69
– ns = 1200 rpm, 2p = 6	70
– ns = 900 rpm, 2p = 8	71
Increased output, 50 Hz	
– ns = 3000 rpm, 2p = 2	72
– ns = 1500 rpm, 2p = 4	73
Increased output, 60 Hz	
– ns = 3600 rpm, 2p = 2	74
– ns = 1800 rpm, 2p = 4	75
Temperature class T6	
Output 50 Hz / 60 Hz	76
Pole-changing motors, 50 Hz	
– ns = 1500/3000 rpm, 2p = 4/2	77
– ns = 1000/1500 rpm, 2p = 6/4	78
– ns = 750/500 rpm, 2p = 8/4	79
– Fan application	80

Pole-changing motors, 60 Hz
– Standard version, fan application

81

Motors with integral brake, 50 Hz
– 2p = 2, 4, 6, 8
– 2p = 8/4, 8/2

82

83

Motors with external brake, 50 Hz
– 2p = 2, 4, 6, 8

84

86

Coil data for brakes

Compact drive

87

Water-cooled motors, noise class 4, 50 Hz
– 2p = 2, 4

88

Operating Data, High-Voltage Motors

50 Hz
– 2p = 2, 4, 6, 8

89

Dimensions

Surface-cooled, low-voltage motors,
self-cooling with radial-flow fan

– Foot-mounting version 90

– Flange type 92

– Integrated frequency inverter 95

Self-cooling with axial-flow fan, noise class 2 and 3 96

External cooling with axial-flow fan 100

Water-cooled low-voltage motors,
noise class 4

104

Surface-cooled, low-voltage motors,
Motors with integral brake
Motors with external brake

108

109

Surface-cooled high-voltage motors,
self-cooling through radial-flow fans

110

Terminal boxes to 690 V

111

Spare Parts

Spare parts

112

Conversions and Formulae

Conversion of technical units

114

Point of Contact

Your points of contact in Germany

115

Your points of contact worldwide

116

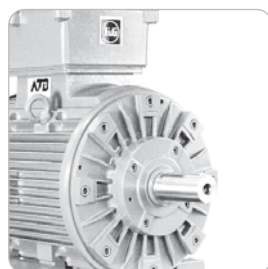

Certificates and Standards

4

ATB Motorentchnik GmbH, with our main office in Nordenham, has been an associate company of ATB Austria Antriebstechnik AG since 2002. It was founded in 1952 under the name Felten & Guillaume. The products, which were recognized worldwide, guaranteed a stable market position. Our most important objective is to satisfy our customers around the world.

ATB Motorentchnik GmbH apply the most stringent quality-control measures, which are checked annually by official government agencies. The certification of the quality assurance was implemented for the first time in 1992. Today we have certification in accordance with:

- **DIN EN ISO 9001:2000** for the Quality Management System
- **ATEX 95** in accordance with **94/9/EG, Appendix IV** for the production of totally-enclosed flameproof motors.



The conservation of our environment through the promotion of non-polluting manufacturing methods, materials and chemicals in energy-saving motors and drives was identified at an early stage and has been integrated into the products. These activities, up to the employment of paint work on water base, resulted in the following certification:

- **DIN EN ISO 14001:1996** for the Environmental Management System



In order to ensure the universal application of the motors within future global markets, conformity certificates have been issued for the motors through various domestic and foreign certification authorities.

Explosion protection certifications e.g.:

- PTB for Europe
- GOST for Russia
- NEPSI for China
- TestSafe for Australia
- IECEx Scheme for the world

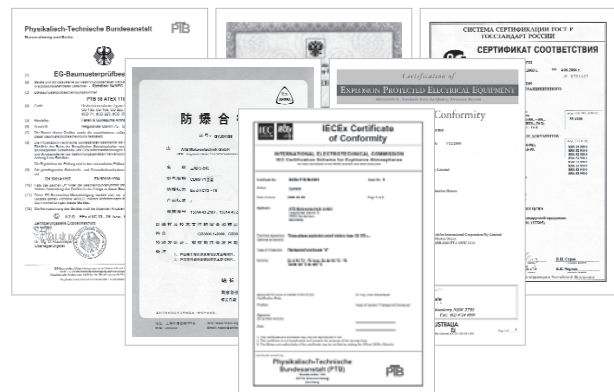

Ship classification authorities e.g.:

- Germanischer Lloyd
- Lloyd's Register
- Nippon Kaiji Kyokai
- American Bureau of Shipping
- Russian Maritime Register of Shipping



All motors correspond to the following international standards and specifications.

As well as these national and international directives, many customers specifications from the chemical and petrochemical industries, and from the mechanical engineering sector, are also complied with.

Standards

Country Title	International IEC - International Electrotechnical Commission	Europe EN - CENELEC European Committee for Electrotechnical Standardisation	Germany DIN/VDE German Industrial Standard/Association of German Electrotechnicians
Electrical rotating machines Rated operation and technical data	IEC 60 034-1	EN 60 034-1	DIN EN 60 034-1/ VDE 0530 Part 1
Process for the stipulation of the losses and the efficiency of rotating electrical machines from tests	IEC 60 034-2	EN 60 034-2	DIN EN 60 034-2/ VDE 0530 Part 2
Protection types of rotating electrical machines based on overall construction (IP-Code) - Introduction	IEC 60 034-5	EN 60 034-5	DIN EN 60 034-5/ VDE 0530 Part 5
Sub-division of the cooling processes (IC code)	IEC 60 034-6	EN 60 034-6	DIN EN 60 034-6/ VDE 0530 Part 6
Classification of the design types, the installation types and the terminal box location (IM-Code)	IEC 60 034-7	EN 60 034-7	DIN EN 60 034-7/ VDE 0530 Part 7
Terminal markings and direction of rotation for electrical machines	IEC 60 034-8	EN 60 034-8	DIN EN 60 034-8/ VDE 0530 Part 8
Noise emission, limit values	IEC 60 034-9	EN 60 034-9	DIN EN 60 034-9/ VDE 0530 Part 9
Starting performance of three-phase motors with squirrel-cage rotor, except for pole- changing motors	IEC 60 034-12	EN 60 034-12	DIN EN 60 034-12/ VDE 0530 Part 12
Mechanical vibrations of certain machines with a shaft height of 56 mm and higher; Measurement, evaluation and limit values of the vibration	IEC 60 034-14	EN 60 034-14	DIN EN 60 034-14/ VDE 0530 Part 14
Balancing value	ISO 1940	-	DIN ISO 1940
IEC standard voltages	IEC 60 038	-	DIN IEC 60 038
Evaluation and classifications of electric insulation according to its thermal behavior	IEC 60 085	-	DIN IEC 60 085
Three-phase induction motors for general use with standardised dimensions and powers	IEC 60 072-1 ¹⁾	EN 50 347	DIN EN 50 347 ²⁾
Electrical apparatus for explosive atmospheres general provisions	IEC 60 079-0	EN 50 014	DIN EN 50 014/ VDE 0170/0171 Part 1
Electrical apparatus for explosive atmospheres, flameproof enclosure "d"	IEC 60 079-1	EN 50 018	DIN EN 50 018/ VDE 0170/0171 Part 5
Electrical apparatus for explosive atmospheres, increased safety "e"	IEC 60 079-7	EN 50 019	DIN EN 50 019/ VDE 0170/0171 Part 6
Electric operating resources for utilization in areas with inflammable dust	IEC 61 241-1-1	EN 50 281-1-1	DIN EN 50 281-1-1 VDE 0170/0171 Part 15-1-1

Note

Motors series dBD..., CD ... and BD ... fulfill the EN... and VDE ... Standards and Specifications.

As a result of compliance with the above-mentioned IEC publications, special adaptation to foreign specifications is not always required.

1) Applies only for dimensions and frame sizes





2) Concerns only single-speed motors of the Basic Series CD ... and BD ... to 315 M for the temperature class T4

Explosion Protection

6

Explosion Protection Types of Electrical Machines

Explosion protection

Protection type letter symbol	Construction requirements	Protection concept	Application of type of electrical machine
Flameproof enclosure „d“ 	DIN EN 50 018, VDE 0170/0171 Part 5 Apparatus for Zone 1+2 ¹⁾	All potential ignition sources are housed inside a flameproof enclosure whose unavoidable sealing surfaces are therefore designed as flameproof joints, so that, in case of ignition of an explosive atmosphere inside the enclosure, the explosive atmosphere is not transferred to the potentially explosive atmosphere surrounding the enclosure.	All types of motors, e.g. <ul style="list-style-type: none"> ● squirrel-cage motors ● slipring motors ● commutator motors. For all modes of operation (S1 to S9) for severe starting conditions and variable-speed drive units, e.g. by means of frequency inverters.
Increased safety „e“ 	DIN EN 50 019, VDE 0170/0171 Part 6 Apparatus for Zone 1+2 ¹⁾	Here, steps must be taken to ensure that the creation of sparks, electric arcs and inadmissible heating processes is prevented during proper operation of the apparatus.	Only squirrel-cage motors with adapted motor protection switch. t _E -time is a requirement!
Non-sparking „n“ 	DIN EN 50 021, VDE 0170/0171 Part 16 Electrical apparatus for explosive atmospheres. Protection type „n“. Apparatus for Zone 2 ¹⁾ (Zone 2 - Apparatus)	Under normal operating conditions, no sparks, electric arcs or inadmissible temperatures occur. If sparks, electric arcs or inadmissible temperatures occur during normal operation, the enclosures, including the terminal box, must either be constructed to protection type IP54 (i.e. at an excess pressure of 4 mbar they must take more than 30 seconds to drop to 2 mbar [restricted breathing]) or both housing and terminal box must be pressurized by simple means.	Squirrel-cage motors of protection type IP20 for enclosed areas. For installation outdoors, protection type P44 or 1PW24 motor protection switch. All types of motors, e.g. <ul style="list-style-type: none"> ● slipring motors ● commutator motors etc with motor protection switches and overpressure monitoring. Prevention of discharge of sparks created under normal operating conditions. Manufacturers' information about these measures.
Dust protection 	DIN EN 50281-1-1, VDE 0170/0171 Part 15-1-1 Apparatus for Zone 21 + 22 ²⁾	The ignition protection type is based on the limitation of the maximum surface temperature of the casing and on the restriction of the dust entry, through the utilization "dust-sealed" or "dustproof" housings.	All electrical motors with protection through housings with limitation of the surface temperature

Note

1) DIN EN 60 079-14, VDE 165 Part 1, Electrical Equipment for Gas Hazardous Areas (except for mining)

2) DIN EN 50281-1-2, VDE 0165 Teil2, Electric Equipment for Utilization in Areas with Inflammable Dust

Explosion protection of flameproof motors

The motors have been tested and certified in accordance with the new European Directive 94/9/ EC (ATEX 95) by the German Federal Institute of Physics and Metrology (PTB). They therefore comply with the latest European regulations. The Directive regulates the type of devices and protective systems suitable for use in hazardous areas and will be applicable from 30.06.2003 throughout Europe for the marketing of this equipment.

The three-phase motors of the version series dBD, CD and BD are explosion-proof in the explosion protection rating "Flameproof Enclosure", in accordance with DIN EN 50 014, VDE 0170/0171 for the groups IIC and IIB and temperature class T3 to T6.

The standard version of the CD series motors complies with the requirements of the highest explosion protection group (IIC) and temperature class T4, which also cover all lower groups and temperature classes. The BD and dBD series comply with the requirements of explosion protection group IIB and temperature class T4.

The issued test certification does not contain electrical data for the tested motor. It merely confirms that the motor is inherently protected against explosion due to its flameproof construction. The specification of electrical data is the sole responsibility of the manufacturer. The observation of temperature limits is certified by means of appropriate tests.

Motors of temperature class T4 have the same output as standard, non-explosion-proof motors. With reference to the frame size and the rated output of temperature class T5 and T6 motors must be amended, taking into account the permissible enclosure temperatures.

The terminal box is, as standard the explosion protection rating "increased safety" (e.g. motor construction designation EEx de). To cater for the various installation methods used in different countries, motors can also be supplied with a terminal box with "flameproof enclosure" (motor construction designation e.g. EEx d).

The motor chamber and the terminal compartment of both versions are isolated from each other to prevent explosion. The winding end leads are fed into the terminal compartment through flameproof cable entries.

Due to their high degree of protection, the motors can be used under all operating conditions in all zone 1 and 2 areas, under all conditions of use.

They can be used in hazardous areas in which the local and operational conditions can cause gases and vapors to accumulate and mix with air to form a flammable mixture. Due to their construction, the motors are protected against ingress of water and against electrical, chemical, thermal and mechanical influences, to the extent that their explosion protection remains intact under normal use.

Construction designation of the motor, e.g.:

 0032  II 2G EEx de IIC T4

Explosion Protection

Explosion protection and categories of electrical machines

Extend dust explosion protection EN 50281-1-1 and EN 50281-1-2

Work applications	Presence of an explosive dust atmosphere	Sometimes	Seldom or short-term	Seldom or short-term
	Dust type	All types	Conductive	Non-conductive
	Zone	21	22	22
Operating resources	Device group	II	II	II
	Device category	2D	2D	3D
	Protection type	IP65	IP 65	IP 55
	Temperature	max. 120 °C	max. 120 °C	max. 120 °C
	Housing temperature			
	Certification	EU Construction sample of the testing agency	EU Construction sample of the testing agency	EU Conformity declaration of the manufacturer
	Designation	II 2D T120°C IP 65	II 2D T120°C IP 65	II 3D T120°C IP 55

Dust explosion protection

Dust-explosion-protected motors are certified by PTB according to the new Directive 94/9/EG and correspond to DIN EN 50281-1-1.

A significant feature of the dust explosion protection is the IP protection. Depending on environmental conditions, different requirements are placed on the dust sealing of the motor.



The limitation of the surface temperature of the motors to a value which is below the ignition and glow temperature of the surrounding dust is also an important factor for dust explosion protection.

The following applies:

Surface temperature of the motors < 2/3 of the ignition temperature of the dust-air mixture and surface temperature < glow temperature at 5 mm dust layer thickness –75 K.

The user must stipulate the category and maximum permissible surface temperature according to frequency and probability of occurrence and the dust type. Caution: Conducting and/or non-conducting dust changes the device category.

Construction designation of the motor:

 0032  II 2D T120 °C IP65

The motors can also be used in dust and gas explosion-proof at the same time.

Information on the introduction of the Directive 94/9/EG (ATEX 95)

The regulations concerning the construction and operation of electrical equipment in hazardous areas have been laid down for many years in European standards under the Directive 76/117/EC and several supplements. The transition to the two new Directives 94/9/EC (ATEX 95) and 99/92/EC (ATEX 137) has involved a thorough revision and harmonizing of the European regulations.

Directive 94/9/EC harmonizes the regulations of the individual member states with regard to the previously differing requirements of apparatus and protective systems. Through these measures, the objectives of removing commercial barriers within the EC and of standardizing basic safety features have been achieved. In specialist circles, the directive is often referred to by the abbreviation "ATEX 95" (abbreviation of the French name for the directive).

In future, the construction requirements for operation in hazardous areas will be specified by the Directive 99/92/EC (ATEX 137).

The integration of the directives into German law was implemented in 1996 with the same two-part structure: the Device Safety Law with the explosion protection law (ExVO) for ATEX 95, and through the operational safety ordinance (BetrSichV) for the ATEX 137. With this, a whole series of old specifications, among other things, the ElexV, have become invalid.

An essential feature of ATEX 95 is an additional classification and identification of devices and protective systems in categories. These categories were defined according to the

zone divisions of operating areas, based on the likelihood of explosive atmospheres. In this way, equipment can be more easily assigned for use in the appropriate zones of operating areas.

The external CE mark and the device group specified on the rating plate, such as "II 2G" for Zone 1 apparatus in explosive atmospheres consisting of gases, indicate that the motors are compliant with the requirements of the new directive. The affixing of the CE mark and the issuing of the relevant declaration of conformity by the manufacturer are subject to the following requirements:

- The manufacturer must have a certified quality assurance system in accordance with ISO 9000, with an additional certificate for quality assurance in the production of explosion-proof apparatus in accordance with ATEX 95.
- The apparatus concerned must have an EC type testing certificate from an accredited test authority (not required for Category 3 apparatus).

During the transition period (up to 30.06.2003) the manufacturer and the user had the right to proceed in accordance with both the old and the new regulations.

Permissible temperatures for electrical equipment

DIN EN 50 014, VDE 0170/0171 Explosion protection groups IIA; IIB; IIC		
Ignition temperature of medium relative to temperature limit	Temperature class	Permissible surface temperature of apparatus incl. ambient temperature of 40 °C (temperature limit)
Above 450 °C	T1	450 °C
Above 300–450 °C	T2	300 °C
Above 200–300 °C	T3	200 °C
Above 135–200 °C	T4	135 °C
From 100–135 °C	T5	100 °C
From 85–100 °C	T6	85 °C

Since July 1 2003 all new products that are brought onto the market must comply with the new ATEX 95 Directive. The supply of spares for the old versions must be ensured for a further ten years at least.

Existing equipment may still be operated. However, this must be upgraded by 30.06.2006 to comply with the minimum requirements of ATEX 137.

Permissible employment of motors according to their classification by zone division

Group	Category	Zone classification	Definition acc. to Safety Instructions	Certification compulsory
Flammable gases, vapours and mists				
II	1G*	0	Zone 0 covers areas in which an explosive atmosphere, consisting of a mixture of air and gases, vapours or mist is present frequently, for long periods of time, or permanently.	Yes
II	2G	1	Zone 1 covers areas in which an explosive atmosphere consisting of gases, vapours or mist is likely to occur from time to time.	Yes
II	3G	2	Zone 2 covers areas in which an explosive atmosphere consisting of gases, vapours or mist is not likely to occur, and if it does, is likely to occur only rarely and for short periods of time.	No
For combustible dust				
II	1D*	20	Zone 20 covers areas in which an explosive atmosphere, consisting of a mixture of dust and air is present frequently, for long periods of time, or permanently.	Yes
II	2D	21	Zone 21 covers areas in which an explosive atmosphere consisting of a mixture of dust and air is likely to occur from time to time.	Yes
II	3D	22	Zone 22 covers areas in which an explosive atmosphere consisting of airborne dust is not likely to occur, and if it does, is likely to occur only rarely and for short periods of time.	No

* Not common for electrical motors

Explosion Protection

Explosion protection types and categories of electrical machines

10

Examples of the classification of flammable gases and vapors according to temperature class and explosion group DIN VDE 0165

	Group	Temperature Class					
		T1	T2	T3	T4	T5	T6
Firedamp protection	I	Methane (firedamp)	-	-	-	-	-
Explosion protection	IIA	Acetone, Ammonia, Benzol, Acetic acid, Ethane, Ethyl acetate, Ethyl chloride, Carbon monoxide, Methane (firedamp) Methanol, Methyl chloride, Propane, Toluene	I amyl acetate, n butane, n butyl alcohol, Cyclohexanon, Acetic anhydrid, Natural gas, Liquefied gas	Hexane, Benzine, Diesel fuels, Aviation fuel, Domestic oil, Petroleum ¹⁾	Acetaldehyde, Ether	-	-
	IIB	Coke-oven gas, Water gas (carburetted)	1,3 butadiene Ethyl alcohol, Ethylene, Ethylene oxide	Petroleum ¹⁾ , Isoprene, Hydrogen sulphide	Ethyl ether	-	-
	IIC	Hydrogen	Acetylene	-	-	-	Carbon disulfide

Note

1) depending on composition

Flammable gases and vapors are classified by groups and temperature classes which are designated using short alphanumeric codes. Codes IIA to IIC refer to the group that defines the nature of the gap in the machines and codes T1–6 indicate the temperature class which stipulates the machine's permissible external temperature.

The group/temperature classes assigned to various gases and vapors are summarized in the table on the right.

Note about the table:

Additional examples are provided in the publication "Safety engineering characteristics of combustible gases and vapors" by Nabert/Schön, Deutscher Eichverlag, Berlin.

Table of conformity certificates

Height of shaft	CD... ¹⁾		BD... ³⁾	BD...B/R ⁴⁾
63	99 ATEX 1051	IECEX PTB 06.0021	99 ATEX 1091	
71	99 ATEX 1051	IECEX PTB 06.0021	99 ATEX 1091	
80	98 ATEX 1106	IECEX PTB 06.0009	98 ATEX 1107	98 ATEX 1109
90	98 ATEX 1106	IECEX PTB 06.0009	98 ATEX 1107	98 ATEX 1109
100	98 ATEX 1106	IECEX PTB 06.0009	98 ATEX 1107	98 ATEX 1109
112	98 ATEX 1106	IECEX PTB 06.0009	98 ATEX 1107	98 ATEX 1109
132	98 ATEX 1106	IECEX PTB 06.0009	98 ATEX 1107	98 ATEX 1109
160	98 ATEX 1106	IECEX PTB 06.0009	98 ATEX 1107	
180	99 ATEX 1045	IECEX PTB 06.0022	99 ATEX 1091	
200	99 ATEX 1082	IECEX PTB 06.0023	99 ATEX 1091	
225	98 ATEX 1106	IECEX PTB 06.0009	98 ATEX 1107	
250	98 ATEX 1106	IECEX PTB 06.0009	98 ATEX 1107	
280	98 ATEX 1106	IECEX PTB 06.0009	98 ATEX 1107	
315	98 ATEX 1106	IECEX PTB 06.0009	98 ATEX 1107	
355	04 ATEX 1001	IECEX PTB 06.0024	04 ATEX 1095	
400	03 ATEX 1144 ²⁾	IECEX PTB 06.0025	04 ATEX 1096 ²⁾	
450	99 ATEX 1026 ²⁾	IECEX PTB 06.0026	01 ATEX 1122 ²⁾	
500 ⁵⁾			03 ATEX 1129 ²⁾	

Note

- 1) Construction designation II 2 G/D EEx de IIC T3...T6 and EEx d IIC T3...T6
- 2) Construction designation only gas explosion protection
- 3) Construction designation II 2 G/D EEx de IIB T3...T6 and EEx d IIB T3...T6
- 4) Construction designation II 2 G/D EEx de IIB+H2 T3...T6 and EEx d IIB+H2 T3...T6
- 5) Type dBD

Conformity certificate for the explosion-protection rating "flameproof enclosure", temperature class T3...6 and dust protection through casings

There are EU version-type conformity certificates for the version series CD ..., BD ..., dBD... and BD...B/R according to the Directive 94/9/EG (ATEX 95).

These certificates, issued up to temperature class T6 for three-phase asynchronous motors of the explosion protection rating "d", do not include any ratings for the appropriate motor type. They merely confirm that the motor is explosion protected due to its tested flameproof construction. In addition, the following ratings, which differ from the standard versions, are certified. These figures must be stated on the motor's rating plate:

- Rated voltages up to 1000 V, from frame size 355 up to 6600 V
- Rated frequency under or over 50 Hz, e.g. 60 Hz
- Pole-changing motors, e.g. 4/2 or 6/4 poles
- Ambient temperatures from -55 °C to 60 °C
- From -55 °C to -20 °C also without heating
- Altitude of installations above 1000 m m.s.l.
- Installation of TF as sole protection against inadmissible heating with operating mode S1, S2, S3, S4, S5, S6, S7, S8, S9 or S10.
The sole protection is achieved only through a combination of TF (thermistors in accordance with DIN 44081) and tripping devices with conformity mark II (2)G.
- In case of built-in TF, the only means of protection possible is the power feed via frequency inverter with variable frequency for the motor speed regulation.
- Temperature classes T3 to T6
- Dust explosion protection II 2D for zone 21

It is permissible to design the motors for several of the aforementioned deviations (e.g. for operating mode S2 and ambient temperature 60 °C).

Type Code

12

Type code

			1	2	3	4	5	-	6	7														
			1	2	3	4	5	6	7	8	9	10	11	12	13	14	15	16	17	18	19	20	21	...
Pos.	Feature	Code	Meaning																					
1	Explosion protection (optional)	d E	flameproof enclosure European-standard																					
2	Explosion protection	C CE B e (E) n	flameproof IIC flameproof IIC + increased safety flameproof IIB increased safety non sparking Version																					
3	Type of motor	AR D IGL	terminal room three-phase motor integrating converter-housing																					
4	Frame size	- 63 - 71 ...	shaft height 63 etc.																					
5	Core length	K, S M L L1 ...	small medium long etc.																					
-	hyphen																							
6	No. of poles	4 8/4 12/8/4 ...	4-pole 8/4-pole 12/8/4-pole																					
7	Design	A AR B D E F H I IT K O R S U W X Y 0, 1, 2, ...	axial-cooling, unidirectional fan, class 2 axial-cooling reduced, class 3 brake integrated (built-in) terminal box - flameproof enclosure terminal box - increased safety external fan high-voltage motor integrated inverter IT-protective scheme connection cable type without fan speed pulse generator (built-in) special brake attached (built-on brake) peak voltage stability 2.15kV water-cooled, class 4 increased power high-efficiency motor design no.																					

If it isn't specified, single-position could be dropped.

To frame size 355 - any number of pole - the motor bearings are designed so that they can be used as described below without modification.:

- IM B3 as IM B6, IM B7, IM B8, IM V5*, IM V6*
- IM B5 as IM V1*, IM V3*
- IM B35 as IM V15*, IM V36*
- IM B14 as IM V18, IM V19

Exception: For the vertical version types marked with *, protective devices must be fitted to provide protection against dripping water and to prevent foreign bodies from falling into the units.

High-voltage motors are available only in the versions IM B3, IM B35 and IM V1.

Mountings to DIN EN 60 034-7 **Other construction types on request**

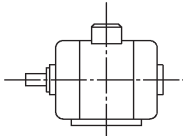
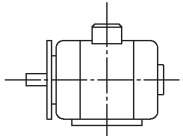
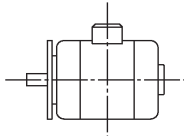
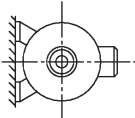
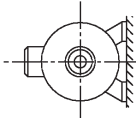
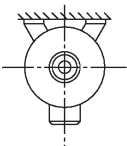
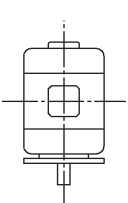
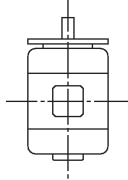
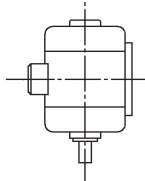
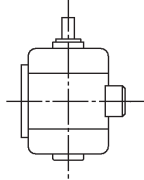
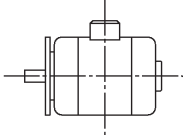
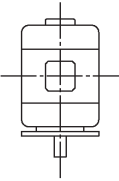
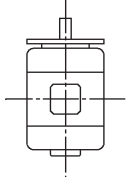
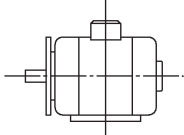
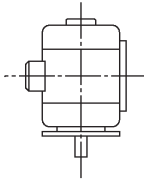
					
IEC Code I IEC Code II Explanation	IM B3 IM 1001 Foot mounting, feet at bottom	IM B35 IM 2001 Foot mounting, feet at bottom, with additional flange mounting, with access from housing side	IM B5 IM 3001 Flange bearing plate on drive side, with access from housing side	IM B6 IM 1051 Foot mounting, feet to the left side (viewed from drive side)	IM B7 IM 1061 Foot mounting, feet to the right side (viewed from drive side)
					
IEC Code I IEC Code II Explanation	IM B8 IM 1071 Foot mounting, feet above	IM V1 IM 3011 Flange mounting on drive side of the flange, with access from housing side, drive side below	IM V3 IM 3031 Flange mounting on drive side of the flange, with access from housing side, drive side above	IM V5 IM 1011 Foot mounting, drive side below	IM V6 IM 1031 Foot mounting, drive side above
					
IEC Code I IEC Code II Explanation	IM B14 IM 3601 Flange mounting on drive side of the flange, no access from housing side	IM V18 IM 3611 Flange mounting on drive side of the flange, no access from side below	IM V19 IM 3631 Flange mounting on drive side of the flange, no access from side above	IM B34 IM 2101 Foot mounting, feet at bottom, with additional flange mounting on no access from housing side	IM V15 / IM V35 IM 2011 / IM 2031 Foot mounting, with additional flange mounting on drive side of the flange, drive side below/above, access from housing side

Materials, Plates and Labeling

14

For casings, end shields, terminal boxes and fans

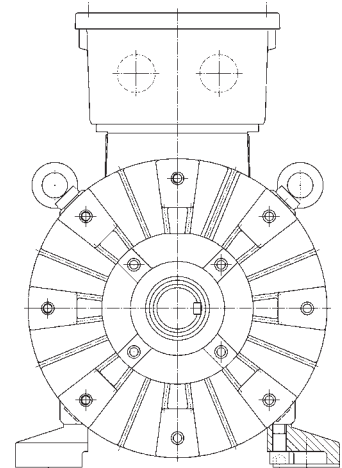
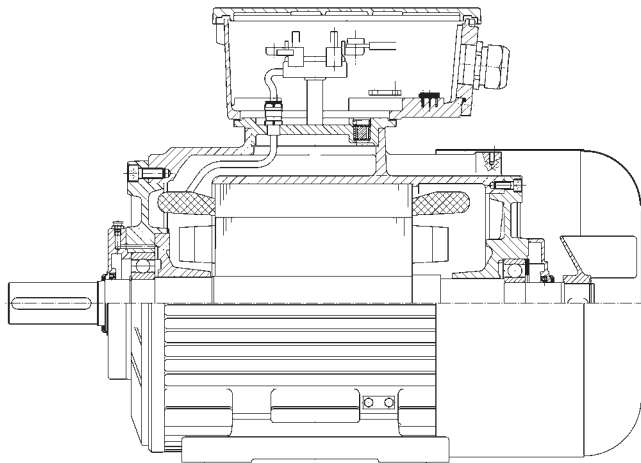

Materials for casing, end shields, terminal boxes and fans

Frame size	Housing type		End shield	Terminal box		Fan cowl	Radial-flow fan		Axial-flow fan
	Material	Feet		EEx e	EEx d		2-pole	4, 6, 8-pole	
63	Gray cast iron	Gray cast iron	Gray cast iron	Gray cast iron	Gray cast iron	Omitted	Omitted	Omitted	
71		Bolted		Bolted	Bolted	Sheet steel	Plastic ¹⁾	Plastic ¹⁾	
80									
90									
100									
112									
132									Plastic
160									
180									
200							Cast aluminum alloy ²⁾	Cast aluminum alloy ²⁾	
225									
250									
280									
315									
355						Steel			
400	Steel	Steel	Steel			welded	Steel	Steel	
450	welded	welded	welded				welded	welded	

Note

1) For special operating conditions, e.g. low temperature, fans made of cast aluminum or steel can also be supplied for the frame size range 63 to 200.

2) Fans of steel on request

Labeling

Rating and test information is contained on a single plate attached to the housing. A duplicate is attached to the inside of the EEx e terminal box lid. The plates are made of stainless steel (material 1.4300)

Installation at normal, high and low Temperatures

The standard motors are suitable for installation outdoors, in humid and dusty atmospheres (industrial climate) at temperatures from -20°C to $+40^{\circ}\text{C}$.

Special-purpose versions for an extended ambient temperature range from -55°C to $+60^{\circ}\text{C}$ are available. In these cases a corresponding construction designation is made on the test label.

Motors suitable for use at extremely low temperatures are designed in accordance with the table on the right.

The PTB conformity certificate for ATB motors with shaft heights 63 to 315 applies for minus temperatures to -55°C . With temperatures lower than -20°C , the motors are supplied in two versions, with or without anti-condensation heating. In case of implementations with anti-condensation heating, the heating must be used to prevent a drop of the motor temperature below -20°C .

Motors intended for on-board or offshore installation conform to the regulations of the respective classification authorities. To ensure safe on-deck installation, the motors have a series of additional design features (see page 34). For motors with this implementation, construction-type conformity certificates from different ship classification authorities, e.g. Germanischer Lloyd, must be available.

Use at low temperatures with heaters

Component	-20°C	-40°C	-55°C
Bearing	Normal	Normal	Normal
Bearing grease	Normal	Normal	Normal
Shaft seal	Normal	Normal	Special
Fan	Normal	Al-Fan	Al-Fan
Stator winding	Normal	Normal	Normal
Heater	No	Required	Required
Cast parts	EN-GJL-200	EN-GJL-200	EN-GJL-200
Shaft	E335	S355J2G3	S355J2G3
Item testing	Normal	Normal	Normal
Fastening screws	8.8	A2-70	A2-70
Eye bolts	Normal	Special	Special
Cable entry	Normal	Special	Special
Paintwork	Normal	Normal	Special

Use at low temperatures without heaters

Use as with anti-condensation heating, however with the following deviations

Component	-20°C	-40°C	-55°C
Bearing	Normal	Normal	Special
Bearing grease	Normal	Normal	Special
Steel parts	S235J2G3	S355J2G3	S355J2G3
Item testing	Normal	Increased	Increased
Fastening screws	8.8	A2-70	A2-70

Paintwork, Protection Types

16

Paintwork system	Standard paintwork	Paintwork for normal requirements in special colours to RAL specifications	Acid protection paintwork for heavy-duty applications	Paintwork for offshore areas
Pretreatment	All parts cleaned and degreased, steel cast parts and grey cast iron parts sandblasted (SA 2,5 DIN 55 928)			
1.) Primer for cast parts	Synthetic alkyd resin primer or acrylic lacquer min. 20µm			Two-component zinc primer coating with epoxy resin base min. 70 µm
1.) Primer for steel parts	Single component deep-penetrating bonding primer on alkyd resin base min. 40µm			Two-component zinc primer coating with epoxy resin base min. 70 µm
2.) Primer	Frame size ≥ 160 Single component deep-penetrating bonding primer alkyd resin base min. 40 µm		Two-component acrylic lacquer polyacrylic base min. 50 µm	Two-component acrylic lacquer polyacrylic base min. 60 µm
Top coat	Two-component structure paint on polyurethane base min. 40 µm	Two-component acrylic lacquer min. 40 µm	Two-component acrylic lacquer min. 40 µm	Two-component acrylic lacquer 2 x min. 40 µm
Coat thickness	Frame size ≤ 132 min. 60 µm Frame size ≥ 160 min. 100 µm		min. 110µm	min. 210µm
Colour	RAL 5009 azure blue	All colors to RAL	RAL 7031 blue-gray RAL 7032 pebble-gray	RAL 7032 pebble-gray
Mechanical strength	Non-abrasive, elastic, scratch-resistant impact-resistant			
Corrosion resistance	Resistant to water, steam and saltwater	Resistant to water partially resistant to saltwater	Highly resistant to water, steam and saltwater	
Chemical resistance	Resistant to solvents, chemicals, synthetic coolants, hydraulic liquids and cleaning agents		Highly resistant to chemicals	
Temperature range	-40 °C to +130 °C		-50°C to +130°C	-40°C to +130°C

Note

Special paintwork deviating from this is available on request.

Available protection types to DIN IEC 60034-5

Temperatur class Frame size	T4 RT ≤ 40 °C	T4 RT > 40 ≤ 60 °C	T6 RT ≤ 40 °C
63-450	IP55	IP55 ²⁾	IP55
63-450	IP56	-	-
63-355 ³⁾	IP66 ¹⁾	-	-
63-315 ⁴⁾	IP55	IP55 ²⁾	-

Note

1) IP66 in DIN EN 60034 Part 5 not provided

2) Output adaptation required

3) Larger motors available on request

4) Type CD ... X

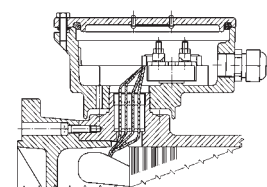
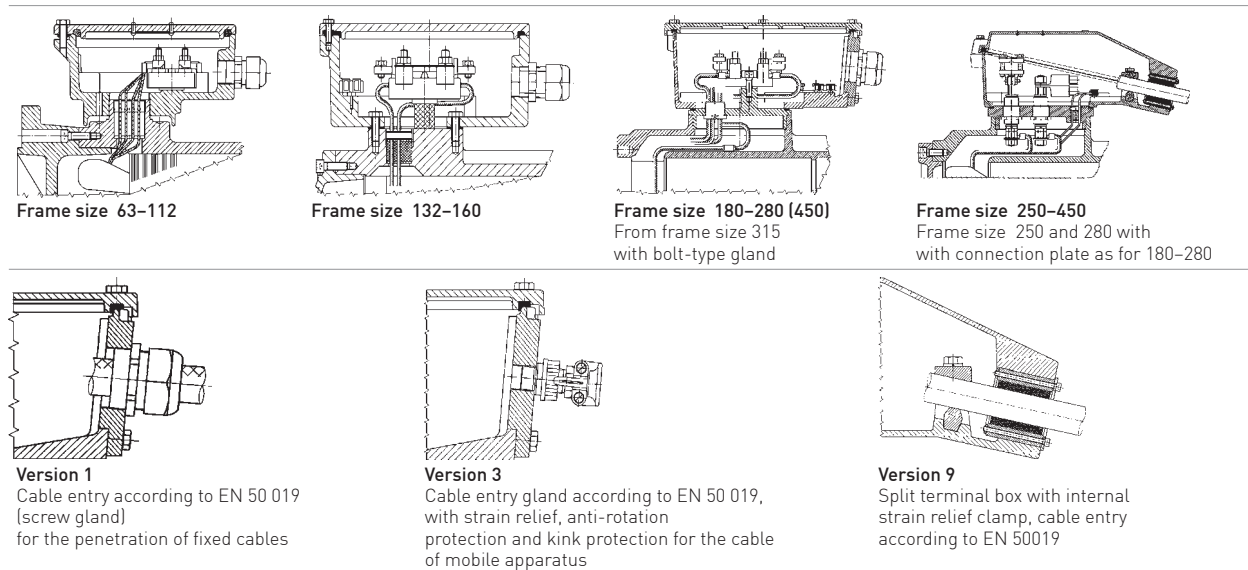

Frame size 63–112

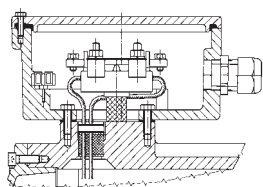

Frame size 132–160

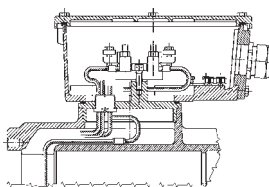

Frame size 180–280 (450)
From frame size 315
with bolt-type gland

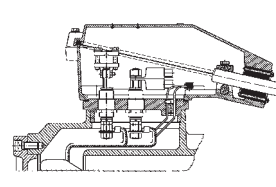

Frame size 250–450
Frame size 250 and 280 with
with connection plate as for 180–280

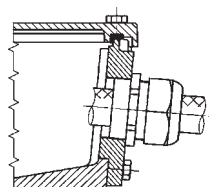

Version 1
Cable entry according to EN 50 019
(screw gland)
for the penetration of fixed cables

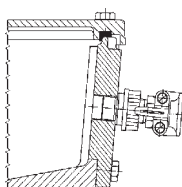

Version 3
Cable entry gland according to EN 50 019,
with strain relief, anti-rotation
protection and kink protection for the cable
of mobile apparatus

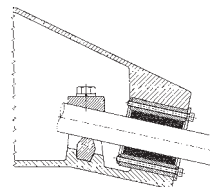

Version 9
Split terminal box with internal
strain relief clamp, cable entry
according to EN 50019

Protection type

For the gas explosion protection according to EN 50 019 of the explosion protection rating "increased safety" EEx e II, as well as the protection type IP56 according to DIN EN 60 034 Part 5 or according to EN 50 018, the terminal boxes correspond to the explosion protection rating EEx d IIC. For dust explosion protection they are implemented in the protection type IP 66 according to EN50281. In case of explosion protection EEx e II and dust explosion protection they are provided with a cable entry corresponding to the protection type and an oil-resistant cover seal. The cover fixing screws are protected against corrosion and captive mounted (not at high-voltage). Cable entries with EEx d IIC explosion protection available on request.

Position

The terminal boxes in the standard form are fitted to the top of the machine. On request they can also be fitted on the side. From frame size 63, they can be rotated by 4 X 90 degrees to enable connection from all directions. From frame size 132, this can be achieved without rotating the connection plate.

Power line bushings and terminals

The winding end leads are fed into the terminal compartment through flameproof cable entries. For low-voltage motors multiple penetration or single penetration systems are used for AC voltages up to at least

690 V. Special versions for 1000 V are also available (extra-cost option).

High-voltage motors are fitted with single penetration systems according to the rated voltage. For frame sizes 315–450, the terminals for connection without cable lugs are placed directly on the bolt-type glands.

Terminal box standard version EEx e II

The terminal boxes of the low voltage motors have metric threads, assigned in accordance with DIN 42 925 with cable entries to DIN EN 50 262, certified to DIN EN 50019.

For frame size 180 and above, the terminal boxes are equipped with a screw-on plate for optional installation of screw glands, cable glands or a split cable entry gland. Above frame size 250, longitudinally split terminal boxes are also available.

An additional terminal box for thermal monitoring or anti-condensation heaters is also available above frame size 132. It is bolted to the motor terminal box or, on frame sizes 355 to 450, fitted to the housing.

The high-voltage motor terminal boxes conform to DIN 42 962. On request, the star point can be located in a second terminal box. The terminal boxes are protected to EEx e II "increased safety", as defined by EN 50 019, and are supplied in Version 9.

The various cable entry components (extra-cost option) and their thread sizes are listed in the table on page 18.

Terminal Boxes

18

Mains cable entry for EEx e terminal boxes

Version	Frame size	63	71	80	90	100	112	132	160	180	200	225	250	280	315	355	400-450	High-voltage
1	Threaded version	1 x M25 x1,5			1 x M32 x1,5			1 x M40 x1,5		1 x M50 x1,5		1 x M63 x1,5		Not available				
	For cable external Ø mm	13-19 ABB 8-17			12-21			17-28		21-35		27-48		Not available				
3	Threaded version	1 x M25 x1,5			1 x M32 x1,5			1 x M40 x1,5		1 x M50 x1,5		1 x M63 x1,5		1 x M80 x2 1 x M90 x2		On request		
	For cable external Ø mm	11-16			15-20			19-27		26-34		35-46		62-68 74-80		On request		
9	For cable external Ø mm	Not available										1 x Ø 48-70 2 x Ø 26-48		1 x Ø 48-70 2 x Ø 48-70		1 x Ø 26-48		

Note

From frame size 132 in pole-changing version or Y/Δ-startup 2 cable entries for each box.
For thermal monitoring with all versions in additional 1 x screw gland M25 x 1.5.
For heating with all version in additional 1 x screw gland M25 x1,5.

 = Standard version

Possible cross-sections with EEx e for low-voltage

Frame size	Rated cross-section, max. [mm ²]	Rated current, max. [A]	Terminal type	Number of terminals	Thread size
63-112	4	25	U-clamp terminal	6	M5
132, 160	10 (r)	63	U-clamp terminal	6	M6
180-225	70	100	Saddle terminal	6	M8
250-280	120	250	Saddle terminal	6	M12
315	150	250 / 315 ¹⁾	Round terminal	6	M12
355-450	300	315 / 400 ¹⁾	Round terminal	6	M16

Note

1) Material: Cu

Terminal box EEx d IIC

The terminal boxes correspond to EN 50 018 of the explosion protection rating "EEx d IIC".

A threaded bore to ISO DIN 13 is standard on all terminal boxes.

On request, the thread types listed in the table below can also be supplied. Please specify the required thread dimensions when placing your order.

Note: Cable entry parts in protection type

EEx d IIC housings must also conform with and be certified to EN 50 018.

These parts are not associated with the scope of delivery. Flameproof terminal boxes are also available for high-voltage motors.

Cable entry threads for EEx d terminal box for low-voltage motors

Frame size	63	71	80	90	100	112	132	160	180	200	225	250	280	315	355-450
Thread type ISO-DIN 13	1 x M25 x1,5			1 x M32 x1,5			1 x M40 x1,5		1 x M50 x1,5		1 x M63 x1,5		1 x M80 x2		1 x M95 x2
NEMA type NPT	½"			¾"			1"	1¼"	1½"	2"	3"			3½"	

Note:

For thermal monitoring with all versions an additional thread 1 x M25 x1.5 or 1 x 1/2" is possible.

Direct Cable Connection Implementation

Connecting cable, Series CD...K

19

3 Ends 400 V¹⁾, 6 ends 400/690 V¹⁾ – NSSHoeu cable

Frame size	Number of poles	3 winding end leads and earth lead – direct switching system		6 winding end leads and earth lead – pole-changing – Y / Δ startup	
		Without temperature monitoring	With temperature monitoring	Without temperature monitoring	With temperature monitoring
63	2–4	1 cable	1 cable	1 cable	1 cable
71	2–8	4 strands	7 strands	7 strands	10 strands
80	2–8	Cross-section 1,5mm ²	Cross-section 1,5mm ²	Cross-section 1,5mm ²	Cross-section 1,5mm ²
90	2–8	max. 20 A	max. 20 A	max. 20 A	max. 20 A
100	2–8	Outer Ø approx. 13mm	Outer Ø approx. 17,5mm	Outer Ø approx. 17,5mm	Outer Ø approx. 19,5mm
112	2–8				
132	2–8	1 cable	2. additional	2 cable	3. additional
160	2–8	4 strands	cable with 4 strands	each 4 strands	cable with 4 strands
		Cross-section 4mm ²	Cross-section 1,5mm ²	Cross-section 4mm ²	Cross-section 1,5mm ²
		max. 36 A	max. 20 A	max. 36 A	max. 20 A
		Outer Ø approx. 18mm	Outer Ø approx. 13mm	Outer Ø approx. 18mm	AußenØ ca. 13mm
180	2–8	1 cable			
200	L ₁ -2	4 strands			
	4–8	Cross-section 10mm ²			
		max. 65 A			
		Outer Ø approx. 24mm			
	L ₂ -2	1 cable		2 cable	
225	2–4	4 strands		each 4 strands	
		Cross-section 16mm ²		Cross-section 16mm ²	
		max. 87 A		max. 87 A	
		Outer Ø approx. 28mm		Outer Ø approx. 28mm	
250	2–4	only for 500 V			
		1 cable			
		4 strands			
		Cross-section 16mm ²			
		max. 87 A			
		Outer Ø approx. 28mm			
280	2–8	only for 690 V			

Note

Cables included in the scope of delivery. Cable length 1.5. Special lengths on request.

1) Standard output 50 Hz. Consider the rated currents of the cables at different data.

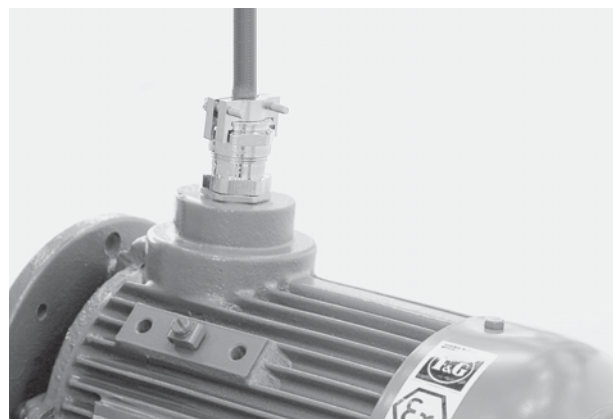

Motor with direct cable connection implementation

Bearing seals

The motors are fitted with external radial or axial seals. Vertical construction types with upward-facing shaft are fitted with a combined radial and axial seal. The seals prevent ingress of water along the shaft into the bearing housing. They have good abrasion resistance and thermal stability and are also resistant to mineral oils, saline solutions and diluted acids. Seals for media not listed above are available on request.

Lubrication

The bearings of motors up to frame size 280 have lifetime lubrication. The deep-groove ball bearings, which are sealed on both sides, are pre-packed with polyurea fiber grease by the bearing manufacturer. They are therefore maintenance-free for the time specified in the upper table on page 27.

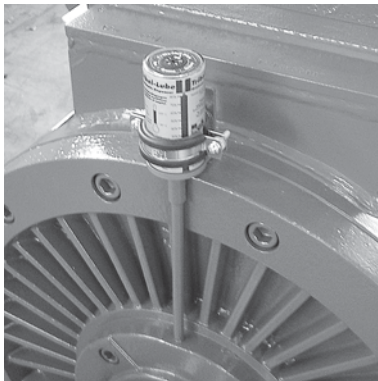

Long-term dispenser

Relubrication and relubrication schedules

Motors above frame size 315 are equipped with relubrication devices with grease distributors. Relubrication devices are also fitted to motors from frame size 225 that are equipped with roller bearings for heavy loads.

Bearings with relubrication devices are packed with lithium-saponified grease. The relubrication intervals are listed in the middle table on page 27.

In case of vertical construction types (V type), the relubrication intervals are to be halved.

The relubrication must be implemented with the same grease type, i.e. grease with same saponification component and same consistence. ATB employs a lithium-saponified anti-friction roller bearing grease with a drop point above 185 °C (e.g. Esso Unirex N 3). See also information plate on motor.

The collecting chamber in the bearing cover is large enough to contain the used grease accumulating during normal service life. Flat grease nipples to DIN 3404 with thread size M10 x 1 are used for lubrication.

There is an option available to employ long-term dispensers for relubrication. They remain free from maintenance for max. 12 months, according to case of application. The dispensers are implemented in the explosion protection rating II 2 G EEx ib IIC T6.

Bearing classification

Frame size	Number of poles	Drive-end bearing all construction types			Non-drive-end bearings (floating bearing)
		Standard (fixed bearing)		Reinforced bearings ²⁾	
63	2, 4	6202 2ZR	-	-	6004 2ZR
71	2, 4, 6, 8	6202 2ZR	-	-	6004 2ZR
80	2, 4, 6, 8	6204 2ZR	-	-	6204 2ZR
90	2, 4, 6, 8	6205 2ZR	-	-	6205 2ZR
100	2, 4, 6, 8	6206 2ZR C3	-	NU 206	6206 2ZR C3
112	2, 4, 6, 8	6306 2ZR C3	-	NU 306	6206 2ZR C3
132	2, 4, 6, 8	6308 2ZR C3	-	NU 308	6308 2ZR C3
160	2, 4, 6, 8	6309 2ZR C3	-	NU 309	6309 2ZR C3
180	2, 4, 6, 8	6310 2ZR C3	-	NU 310	6310 2ZR C3
200	2, 4, 6, 8	6312 2ZR C3	-	NU 312	6312 2ZR C3
225	2, 4, 6, 8	6313 2ZR C3	-	NU 313	6313 2ZR C3
250	2, 4, 6, 8	6315 2ZR C3	-	NU 315	6313 2ZR C3
280	2, 4, 6, 8	6316 2ZR C3	-	NU 316	6315 2ZR C3
315	2	6316 C3	-	NU 316	6316 C3
	4, 6, 8	6318 C3	-	NU 318	6316 C3
355	2	6318 C3	-	NU 318	6318 C3
	4, 6, 8	6320 C3	-	NU 320	6318 C3
		Only Frame size V1 ¹⁾ , V3 ¹⁾		Frame size B3, B5	
400	2	6318 C3	7318 B	NU 318	6318 C4
	4, 6, 8	6322 C3	7322 B	NU 322	6322 C3
450	2	6318 C3	7318 B	NU 318	6318 C4
	4, 6, 8	6324 C3	7324 B	NU 324	6322 C3

Note

1) for vertical operation only

2) Min. radial load required. See page 25.

Bearing-type codes:

Example: 6315.2ZR.L12.C3

6315 = Bearing size

2ZR = Non-rubbing double seal

L12 = Polyurea fiber grease

C3 = Bearing clearance

Up to frame size 400, a locating bearing is used at the drive-end.

Nominal service life

In pure coupling operation, the theoretical service life is more than 50,000 operating hours.





The max. admissible radial and axial loading is indicated in the tables on pages 23 to 25. The calculations are based on a service life of the roller bearings of 20,000 hours.

Drives with a higher radial load, such as belt drives, can be supplied with roller bearings for an additional charge. The minimum radial load specified must be maintained in order to ensure that the bearings roll correctly. For higher axial bearing loads such as occurring with helical gear, special solutions are available on request.

Bearings

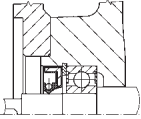
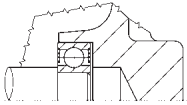
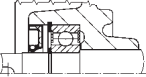
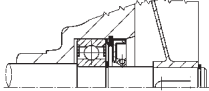
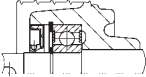
22

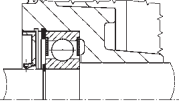
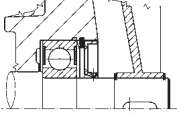
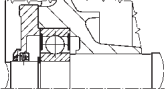
Bearing arrangement in standard motors

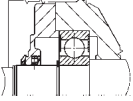
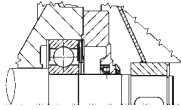
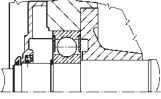
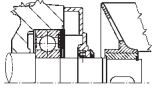
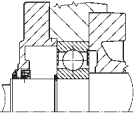
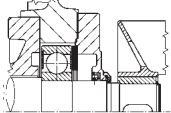
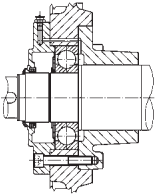
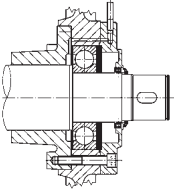
	Drive-end Bearing	Non-drive-end Bearing
Frame size 63		
Frame size 71		
Frame size 80-132		
Frame size 160		
Frame size 180-200		
Frame size 225		
Frame size 250		
Frame size 280		
Frame size 315-450		

Pictorial representation non-binding.

Permissible radial load,
deep groove ball bearing

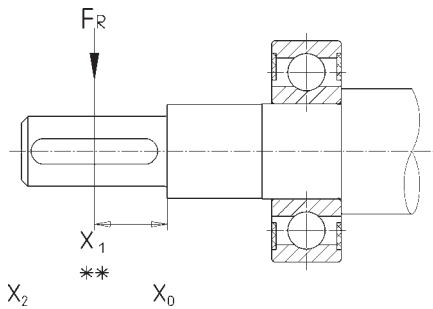

The distance of the point of application of force F_R from the shaft collar should be not greater than the length of the shaft end.

$F_R =$ max. radial load (e.g. overhung belt load + weight of belt pulley) [N]

$$F = \text{Belt pull [N]} = \frac{2 \times K \times M}{D}$$

$$M = \text{Torque [Nm]} = \frac{9550 \times P}{n}$$

$P =$ Rated motor output [kW]

$n =$ Rated motor speed [1/min]

$D =$ Pulley diameter [m]

$K =$ Pre-tension factor, dependent on belt type and approximated as follows

$K = 3$ For normal flat belts without tensioning pulley

$K = 2$ For normal flat belts with tensioning pulley

$K = 2.2$ For V-belts or special-purpose flat belts

The specified values apply to operation at 50 Hz mains. Details for 2-pole motors of frame size 400 apply only to horizontal shafts.

Permissible radial bearing load F_R [N] (deep groove ball bearing)

Frame size	2p	x_2	x_1	x_0
63	2	400	420	450
	4	500	540	570
71	2	390	420	450
	4	490	530	570
	6	560	600	650
	8	610	660	720
80	2	650	710	780
	4	830	900	980
	6	940	1020	1120
	8	1040	1130	1240
90	2	700	770	840
	4	880	970	1060
	6	1010	1100	1220
	8	1110	1220	1340

Frame size	2p	x_2	x_1	x_0
100	2	950	1050	1160
	4	1200	1310	1460
	6	1360	1500	1670
	8	1510	1660	1840
112	2	1400	1540	1700
	4	1760	1930	2130
	6	2010	2200	2440
	8	2220	2430	2690
132	2	1960	2160	2400
	4	2450	2700	3000
	6	2810	3090	3430
	8	3110	3430	3810
160	2	2340	2590	2890
	4	2960	3270	3650
	6	3370	3730	4160
	8	3720	4110	4590
180	2	3180	3530	3970
	4	3970	4410	4960
	6	4550	5060	5700
	8	5010	5570	6270
200	2	3900	4280	4700
	4	4930	5410	6000
	6	5650	6190	6900
	8	6210	6800	7500
225	2	4400	4800	5200
	4	5300	5800	6500
	6	6000	6700	7500
	8	6700	7400	8300
250	2	5300	5800	6400
	4	6600	7200	8000
	6	7600	8300	9200
	8	8300	9100	10100
280	2	5800	6200	6800
	4	7200	7800	8500
	6	8400	9100	9900
	8	7700	8700	10000
315	2	5200	5600	5900
	4	7500	8100	8800
	6	8400	9100	9900
	8	7600	8232	8979
355	2	6300	6600	7000
	4	9200	9800	10400
	6	10300	10900	11700
	8	10280	10941	11692
400	2	5100	5400	5700
	4	9300	10000	10800
	6	10500	11300	12100
	8	11400	12200	13100
450	2	4100	4400	4600
	4	8300	8800	9500
	6	9200	9900	10600
	8	10100	10700	11500

Bearings

24

Permissible axial load,
deep groove ball bearing

Permissible axial bearing loading F_A [N]

For construction types	Frame size	3000 rpm Load to		1500 rpm Load to		1000 rpm Load to		750 rpm Load to	
		← N	→ N	← N	→ N	← N	→ N	← N	→ N
IM B3, IM B5, IM B35	63	200	500	300	600	-	-	-	-
	71	200	500	300	600	400	700	500	800
	80	500	700	700	800	800	1000	1000	1100
	90	500	700	700	900	900	1100	1000	1200
	100	900	1000	1200	1300	1400	1500	1500	1700
	112	1300	1400	1700	1800	2000	2200	2300	2400
	132	1700	2100	2300	2700	2800	3200	3100	3600
	160	2100	2700	3000	3500	3500	4100	4000	4600
	180	2500	3200	3400	4100	4100	4800	4600	5400
	200	3200	4100	4400	5300	5300	6200	6100	6900
	225	3400	4900	4800	6300	5700	7300	6600	8100
	250	4300	5800	5900	7400	7100	8600	8100	9600
	280	4500	6300	6200	8000	7600	9400	8500	10300
	315	4100	5900	6600	8600	7800	9800	9100	11100
	355	4700	6700	6800	10400	8400	12000	9900	13500
	400	4200	6200	7300	11300	8700	12700	9900	13900
450	3700	5700	6300	10700	7900	12300	9100	13500	
		↓ N	↑ N	↓ N	↑ N	↓ N	↑ N	↓ N	↑ N
IM V1, IM V5, IM V15	63	200	500	600	400	-	-	-	-
	71	200	500	300	600	400	700	500	800
	80	500	700	700	900	800	1000	900	1200
	90	500	800	700	1000	800	1200	900	1300
	100	800	1100	1100	1400	1300	1600	1400	1800
	112	1200	1500	1600	2000	1900	2400	2200	2600
	132	1500	2300	2100	3000	2500	3500	2900	3900
	160	1800	3100	2600	4000	3100	4700	3500	5200
	180	2100	3700	2800	4900	3400	5600	4000	6300
	200	2600	4900	3700	6300	4500	7300	5100	8200
	225	2600	5900	3700	7700	4500	8900	5400	9800
	250	3300	7100	4500	9300	5500	10700	6300	12000
	280	3000	8300	4100	10800	5500	12100	6100	13700
	315	600	10400	1800	14900	2000	17600	3300	18900
	355	100	12800	700	18800	1100	21900	2500	23400
	400	7300	0	19400	0	22100	0	23600	0
450	4800	0	14700	0	16900	0	18000	0	
		↓ N	↑ N	↓ N	↑ N	↓ N	↑ N	↓ N	↑ N
IM V3, IM V6, IM V35	63	500	200	600	400	-	-	-	-
	71	500	200	600	400	700	500	700	500
	80	600	500	800	700	900	900	1100	1000
	90	700	600	900	800	1000	1000	1100	1100
	100	900	900	1200	1300	1400	1500	1600	1700
	112	1300	1400	1700	1900	2000	2200	2300	2500
	132	2000	1900	2500	2600	2900	3100	3300	3400
	160	2400	2600	3100	3500	3600	4200	4000	4700
	180	2800	3000	3600	4100	4200	4900	4700	5600
	200	3500	4100	4600	5400	5300	6500	5900	7300
	225	4100	4400	5200	6200	6000	7400	6900	8300
	250	4800	5600	6100	7700	7100	9200	7800	10500
	280	4800	6500	5900	9000	7300	10300	7900	11900
	315	2400	8600	3800	12900	4000	15600	5300	16900
	355	2100	10800	4300	15200	4700	18300	6100	19800
	400	7300	0	19400	0	22100	0	23600	0
450	4800	0	14700	0	16900	0	18000	0	

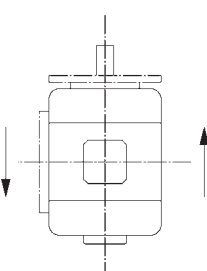
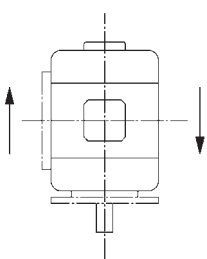
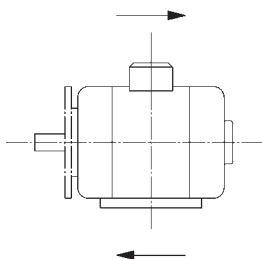

Permissible radial bearing load, cylindrical roller bearing

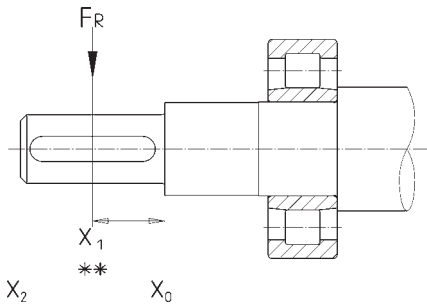

The distance of the point of application of force F_R from the shaft collar should be no greater than the length of the shaft end.

F_R = max. radial axle load (e.g. overhung belt load + weight of belt pulley) [N]

$$F = \text{Belt pull [N]} = \frac{2 \times K \times M}{D}$$

$$M = \text{Torque [Nm]} = \frac{9550 \times P}{n}$$

P = Rated motor output [kW]

n = Rated motor speed [1/min]

D = Pulley diameter [m]

K = Pre-tension factor, dependent on belt type and approximated as follows

K = 3 For normal flat belts without tensioning pulley

K = 2 For normal flat belts with tensioning

K = 2.2 For V-belts or special-purpose flat belts

The specified values apply to operation at 50 Hz mains. Details for 2-pole motors of frame size 400 apply only to horizontal shafts.

Minimum loading $F_{R \min}$ at x_0

Due to their reinforced implementation, the bearings must be loaded with at least the forces indicated in the table. A test operation without load can result in damage.

Permissible radial bearing load - cylindrical roller bearing, Min. loading

Frame size	2p	x_2	x_1	x_0	$F_{R \min}$ at x_0	
CD 100	2	2759	3033	3367	220	
	4	3392	3729	4139	205	
	6	3826	4206	4669	200	
	8	4176	4590	5095	198	
CD 112	2	3702	4054	4480	277	
	4	3766	4984	5507	255	
	6	3766	5621	6212	248	
	8	3766	6137	6780	245	
CD 132	2	5782	6363	7073	475	
	4	6451	7814	8686	428	
	6	6451	8818	9802	412	
	8	6451	9641	10717	404	
CD 160	2	3900	5582	7958	599	
	4	3900	5582	9803	536	
	6	3900	5582	9803	515	
	8	3900	5582	9803	505	
CD 180	2	7912	8735	9749	748	
	4	8900	10715	11959	662	
	6	8900	12108	13513	633	
	8	8900	13196	14727	619	
CD 200	2	10869	11918	13191	1102	
	4	12180	14680	16248	957	
	6	12180	16575	18345	909	
	8	12180	18050	19978	885	
CD 225	2	12850	14319	15672	1302	
	4	12850	17158	19220	1124	
	6	12850	19377	21706	1065	
	8	12850	19392	23719	1035	
CD 250	2	12300	18385	20871	1795	
	4	12300	18385	25620	1519	
	6	12300	18385	28920	1427	
	8	12300	18385	31497	1381	
CD 280	2	15300	20423	22313	2060	
	4	15300	22611	27359	1733	
	6	15300	22611	31044	1624	
	8	15300	22611	31044	1570	
CD 315	2	9800	14183	21892	2060	
	L3	2	5800	8394	15187	2060
		4	13500	20566	32744	2228
	L3	4	8500	12949	27171	2228
6,8		12500	19043	36426	2073	
L3	6,8	7600	11578	24294	2073	
	CD 355	2	16800	24127	25751	2692
L2/L3		2	15000	21542	25481	2692
		4	12400	18475	36219	2930
L2/L3		4	12000	17879	35051	2930
	6	10280	15316	30027	2698	
CD 400	8	10280	15316	30027	2698	
	2	22171	23265	24472	2581	
	4	20000	30096	45197	3675	
	6	19000	28591	50501	3369	
CD 450	8	18000	27087	54618	3216	
	2	20598	21823	23202	2692	
	L2	4	40000	47774	51495	4409
		4	34200	47537	50949	4409
L2	6	32500	49311	56917	4023	
	8	31000	47034	61566	3829	



Bearings

26

Rotor weights series CD

Rotor weights [kg]

Frame size		2p = 2 3000 min ⁻¹	2p = 4 1500 min ⁻¹	2p = 6 1000 min ⁻¹	2p = 8 750 min ⁻¹
63	K	1,5	1,8		
	L	1,5	1,8		
71	K	1,4	1,5		
	L	1,6	1,9	2,6	2,6
80	K	2,2	2,7	3,7	3,7
	L	2,7	3,3	4,5	4,5
90	L ₁	3,8	4,6	5,4	5,4
	L ₂	4,5	5,5	6,7	6,7
100	L	5,9		10,5	
	L ₁		6,9		8,5
	L ₂		8,4		10,5
112	M	8,1	11,9	14,5	14,5
132	S		17,7	20,0	18,4
	S ₁	12,2			
	S ₂	14,5			
	M		22,0	22,8	22,6
	M ₁			22,8	
	M ₂			26,2	
160	M		31,9	38,1	
	M ₁	23,5			33,1
	M ₂	29,2			40,2
180	L	33,1	39,5	48,2	50,9
	M	38,5	48,5		
200	L		55,6	61,4	67,6
	L ₁	50,4	74,0	51,1	95,9
	L ₂	61,4		84,4	
225	S		93,7		104,3
	M	76,0	108,0	122,0	122,0
250	M	99,0	136,0	156,0	176,0
280	S	109,0	144,0	148,0	179,0
	M	122,0	163,0	171,0	207,0
315	S	155,0	215,0	269,0	250,0
	M	181,0	261,0	300,0	290,0
	L ₁	208,0	293,0	366,0	338,0
	L ₂	260,0	360,0	426,0	392,0
	L ₃	340,0	465,0	491,0	452,0
355	M			575,0	582,5
	L ₁	450,0	605,0		
	L ₂	496,0	655,0	879,0	880,0
	L ₃	548,0	737,0		
400	S		785,0	925,0	966,0
	M	640,0	856,0	1006,0	1147,0
	L	688,0	936,0	1107,0	1264,0
	L ₁		865,0	1026,0	1072,0
	L ₂		944,0	1118,0	1169,0
	L ₃				
450	S	783,0	980,0	1133,0	1280,0
	M	838,0	1066,0	1237,0	1399,0
	M ₁	617,0	923,0	1145,0	1217,0
	M ₂	658,0	995,0	1249,0	1330,0
	L	901,0			
	L ₁	720,0	1148,0	1340,0	1541,0
	L ₂	783,0	1288,0	1531,0	1709,0
	L ₃	857,0	1309,0		

Maintenance-free service life with relubrication and coupling operation

Motors with standard output			Motors with increased output (...X, ...W)		
Frame size	Number of poles	RT 40 °C	Frame size	Number of poles	RT 40 °C
63-71	2	20000 h	63-71	2	20000 h
	4, 6, 8	40000 h		4, 6, 8	40000 h
80-90	2	20000 h	80-90	2	15000 h
	4, 6, 8	40000 h		4, 6, 8	30000 h
100-132	2	20000 h	100-132	2	10000 h
	4, 6, 8	40000 h		4, 6, 8	20000 h
160-280	2	20000 h	160-280	2	7500 h
	4, 6, 8	40000 h		4, 6, 8	15000 h

Relubrication intervals for horizontal construction type

Motors with standard output Relubrication interval			Motors with increased output (...X, ...W) Relubrication interval	
Room temperature	Speed up to 1800 rpm	up to 3600 rpm	Speed up to 1800 rpm	up to 3600 r
40 °C	5000 h	2500 h	5000 h	2500 h
50 °C	2500 h	1000 h	2500 h	1000 h
60 °C	2000 h	500 h	-	-

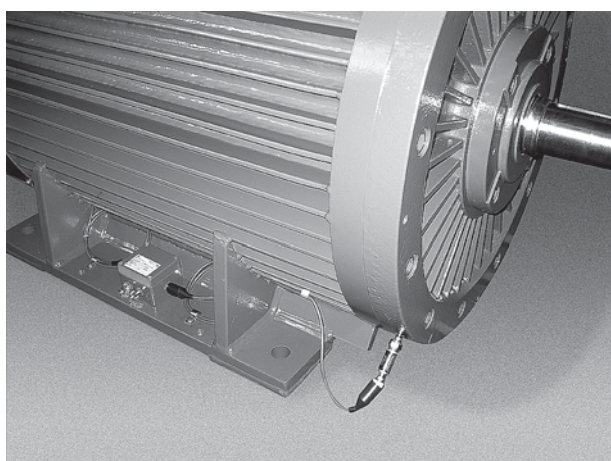

Vibration recorder and box

Bearing monitoring

For the status monitoring of the bearings, the motors can be equipped with temperature sensors, shock pulse and vibration sensors.

PT100 as temperature sensors are mounted within the flameproof enclosure at the bearing points. Standard Implementation in 2 conductor circuit. 3 or 4 conductor circuits on request.

The connection is implemented either in the main terminal box or in separate additional terminal boxes, which are attached to the main terminal box or to the motor housing, according to version. The wiring and boxes can be implemented, as desired, in the explosion protection rating EEx d, EEx e or EEx i.

Shock pulse nipples can be mounted externally at the end shields for the wear status monitoring above frame size 132. In this way, a monitoring with mobile recording units is possible.

For remote monitoring, use shock pulse or vibration sensors with hard wiring. The individual sensors are combined in a separate terminal box. The connection is implemented in explosion protection rating EEx ia IIC T4.

Bearings

Bearing eddy currents, insulated bearings, mechanical limit speeds

Bearing eddy currents, insulated bearings

Through magnetic asymmetries on mains-powered motors a voltage can occur along the shaft. This shaft voltage leads to transients between rotor and stator which flow through the roller bearings. If the voltage exceeds a peak value of 500 mV, the bearings may be damaged. This danger exists primarily in case of larger shaft heights.

This effect can be amplified through operation with frequency inverter. The implementation of the inverter has a decisive influence in this case. Pulse-controlled AC inverters generate particularly high-frequency voltages and currents, depending on the clock frequency and pulse modulation. Output filters in the inverters minimize these effects.

To avoid damaged bearings, an insulated bearing is therefore always installed on the non-drive end for inverter operation with motors from frame size 315.

As well as this, the operator must provide for a large-area grounding of the motor housing, so that the currents circulating between inverter and stator can be diverted through this.

High-voltage motors are provided as standard with an insulated bearing on the non-drive end.

Mechanical limit speeds

With operation of the motors above the rated speed, the limit values of the roller bearings, the strength of the rotating parts, critical rotor speeds and the tip speed of the fans are to be considered. The speeds limits indicated in the opposite table can make necessary measures such as special fans, special bearings or special balancing.

The rotation speeds indicated for inverter operation in the operating data from page 59, are achieved with the standard motor.

Mechanical limit speeds

Poles	Frame size	63/71	80	90	100	112	132	160	180	200	225	250	280	315	355	400	450
2	[rpm]	6000	6000	6000	6000	6000	6000	6000	5220	5220	5220	4000	3600	3600	3600	3000	3000
	[Hz]	100	100	100	100	100	100	100	87	87	87	67	60	60	60	50	50
4	[rpm]	4500	4500	4500	4500	4500	4500	4500	4000	4000	4000	4000	3000	3000	3000	3000	3000
	[Hz]	150	150	150	150	150	150	150	133	133	133	133	100	100	100	100	100
6	[rpm]	4000	4000	4000	4000	4000	4000	4000	3600	3600	3000	3000	2500	2500	2500	2000	2000
	[Hz]	200	200	200	200	200	200	200	180	180	150	150	125	125	125	100	100
8	[rpm]	4000	4000	4000	4000	4000	4000	4000	3600	3600	3000	3000	2500	2500	2500	1500	1500
	[Hz]	267	267	267	267	267	267	267	240	240	200	200	167	167	167	100	100

Shaft ends

The motors normally have a free shaft end with dimensions conforming to EN 50347.

From frame size 63, the shaft ends have an internal thread to DIN 332 Form "D". The feather-keys are designed to DIN 6885 Sh. 1.

Motors with special shafts and/or a second shaft end are available on request at extra cost (does not apply to motors with axial fan and motors with attachments at the non-drive end, e.g. tachometer).

Running smoothness of the shaft ends

The running smoothness of the shaft ends corresponds to EN 50347. On request, the values can be reduced by 50% (extra-cost option).

Balancing

The motors are dynamically balanced with half feather-key. The balance quality corresponds according to DIN ISO 1940 minimum Q2.5.

Special variants, balanced with a full feather-key, are an extra-cost option.

In conformance with DIN ISO 8821, the shaft end faces of the motors are marked as follows:

H = Half-featherkey balancing

F = Full-featherkey balancing

N = Balancing without parallel key

Vibration amplitude

The mechanical vibrations according to EN 60034-14 correspond to Stage A in the standard version. In case of special requirements on the mechanical quiet running, low-vibration version can be supplied (reduced) to Stage B (extra cost option).

Vibration level with free suspension

v_{eff} [mm/s]	Frame size		
	63–132	160–280	315–450
Level A	1,6	2,2	2,8
Level B	0,7	1,1	1,8

Operating noise levels

Noise measurements are performed in a dead room to EN ISO 3744.

The sound pressure level " L_p " and the sound power level " L_w " in dB(A) are indicated for the individual frame sizes in the operating datasheets.

Measured values according to EN ISO 3744 are involved. They apply for rated load at 50 Hz, plus a tolerance of +3 dB(A).

For available variants of low-noise motors, see page 31.

Cooling air quantity and permissible back pressure

If the motors are to be operated above piping systems or under sound insulation cowls, the minimum cooling air quantities listed in the table below must be adhered to. The maximum back-pressures must not be exceeded, so that the self-ventilation functions trouble-free.

Cooling air quantity and permissible back pressure

Frame size	3000 rpm		1500 rpm		1000 rpm		750 rpm	
	Cooling air quantity m ³ /s	Permissible back pressure Pa	Cooling air quantity m ³ /s	Permissible back pressure Pa	Cooling air quantity m ³ /s	Permissible back pressure Pa	Cooling air quantity m ³ /s	Permissible back pressure Pa
71	0,01	20	0,01	10	0,01	5	0,01	3
80	0,03	30	0,03	10	0,02	5	0,01	3
90	0,05	40	0,03	10	0,02	6	0,01	4
100	0,07	50	0,07	12	0,03	8	0,02	4
112	0,08	50	0,06	12	0,03	8	0,02	5
132	0,10	70	0,10	18	0,07	10	0,05	5
160	0,20	90	0,20	30	0,10	15	0,08	8
180	0,40	100	0,30	40	0,15	20	0,10	10
200	0,50	120	0,30	50	0,20	25	0,15	12
225	0,60	120	0,60	50	0,30	30	0,23	15
250	0,70	140	0,50	60	0,33	35	0,28	20
280	0,70	160	0,70	80	0,45	45	0,33	25
315	1,00	160	1,00	80	0,60	45	0,45	25
355	1,50	160	1,20	80	1,00	45	0,80	25
400	2,20	180	1,90	100	1,70	55	1,50	35
450	2,90	200	2,50	120	2,20	65	2,00	45

Special-Purpose Motors

Low-noise motors

31

Noise class 1 Standard version

Radial-flow fans that are suited for rotation in both directions are employed for the standard type. The fans employed have broad, shallow blades. They are capable of conveying large volumes of air efficiently and at low noise levels.

Noise class 2 Axial-flow fans, type series ...A – low-noise

For more exacting requirements, we recommend the low-noise variant with bi-direction axial-flow fan. These fans are available for 2-pole motors from frame size 112 and 4-pole motors from frame size 132. Through the aerodynamic structuring and the optimal angle of attack of the fan blades, a noise reduction for 2-pole motors of up to 10 dB(A) is achieved compared of the standard version. At the same time, the efficiency of the motors is increased due to the decreased power consumption of the fan.

Noise class 3 axial-flow fans in special-purpose design, Design series ...AR – very low-noise

For applications requiring extremely low noise levels, ATB has developed a range of exceptionally quiet, surface-cooled three-phase motors. These motors are approx. 12 dB(A) quieter than their standard, radial-flow fan counterparts, and are quieter even than the low-noise axial-flow fan motors.

These motors achieve the noise values without application of secondary sound insulation measures, such as e.g. sound insulation cowl. Through this, considerable cost savings can be achieved in the establishment of low-noise plants.

In addition, negative effects of additional sound insulating measures, such as heat build-up under the insulating cowl, are avoided.

Operating data can be found on page 58 and 60.

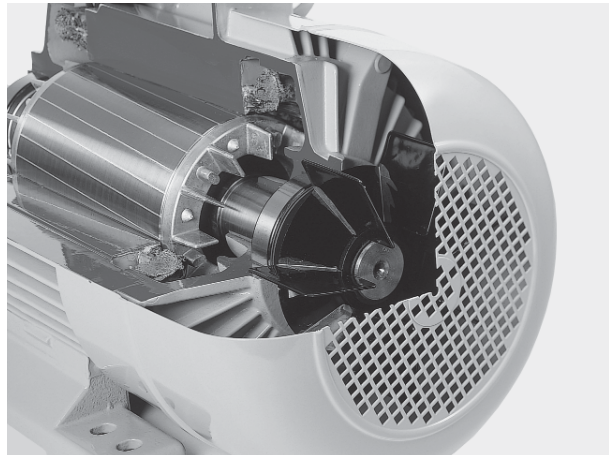

Radial-flow fan, bi-directional (noise class 1)

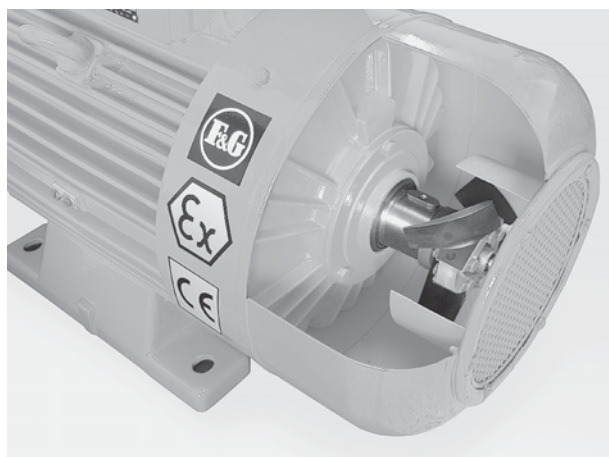

Axial-flow fan, fan cowl with inlet opening, uni-directional (noise class 2 and 3)

Special-Purpose Motors

32

Low-noise motors

Noise class 4 Water cooling design series ...W – lowest-noise version

The water-cooled ATB motors offer the following advantages:

- Reduced noise level due to omission of fan
- Prevention of air turbulence in dusty atmospheres (risk of dust explosion)
- Increased output compared to EN 50347 by a rating stage
- Mounting dimensions of IEC frame sizes are maintained
- Good heat removal without dissipation into surrounding air
- Potential for use of dissipated heat in heat exchangers

The standard versions of the motors are protected to IP55, the special versions to IP56.

They are suitable for installation outdoors and in humid and dusty atmospheres.

The motor housing is a welded steel construction and is double-walled for water-cooling.

To prevent corrosion, the water jacket is coated internal in several layers of synthetic material.

The specified output values apply at a maximum water inlet temperature of 30 °C. The maximum permissible suspended matter content is 30 mg/l.

All motors are equipped with PTC thermistor temperature sensors for overload protection. Cooling water flow monitoring devices are therefore not required. To prevent a buildup of condensation on the winding, especially during longer downtimes, an anti-condensation heater, which applies an AC voltage to the winding, can be connected to the two terminals provided. For extreme conditions, encapsulating the winding heads with silicon rubber is recommended.

Operating data can be found on page 88.

Frequency inverter operation

All systems are suitable for inverter operation without any restrictions.



Water-cooled motor

Low-noise motors

As result of extensive experience and intensive development work in the field of noise reduction for electrical machines, ATB has developed motors that contribute significantly to reducing noise levels. Focusing on low sound radiation, this aim has been achieved with design features such as a solid, low-vibration construction, an optimized magnetic layout, an effective cooling system and tight machining tolerances. The table shows the sound pressure levels achieved. The readings were taken as described under "Operating noise levels" on page 30.

Sound pressure level

Noise class		1 Standard version (radial-flow fan) Temperature class T4, 50 Hz		2 Type series ...A Low-noise version (axial-flow fan) Temperature class T4, 50 Hz		3 Type series ...AR Extremely low-noise version (axial-flow fan) Temperature class T4, 50 Hz		4 Type series ...W Extremely low-noise version water-cooled Temperature class T4, 50 Hz		
Frame size	Output P ₂ [kW]	Sound pressure level L _p [dB (A)]	Sound power level L _w [dB (A)]	Sound pressure level L _p [dB (A)]	Sound power level L _w [dB (A)]	Sound pressure level L _p [dB (A)]	Sound power level L _w [dB (A)]	Output P ₂ [kW]	Sound pressure level L _p [dB (A)]	Sound power level L _w [dB (A)]
ns = 3000 rpm, 2p = 2										
112 M-2	4	63	75	55	67	-	-	-	-	-
132 S ₁ -2	5,5	63	76	55	68	54	67	-	-	-
132 S ₂ -2	7,5	63	76	55	68	54	67	-	-	-
160 M ₁ -2	11	66	79	56	69	54	67	15	50	63
160 M ₂ -2	15	66	79	56	69	54	67	18,5	50	63
160 L-2	18,5	66	79	56	69	54	67	22	50	63
180 M-2	22	69	82	58	71	57	70	30	51	64
200 L ₁ -2	30	71	85	60	74	58	72	37	52	66
200 L ₂ -2	37	71	85	60	74	58	72	45	52	66
225 M-2	45	72	86	60	74	59	73	55	54	68
250 M-2	55	75	89	64	78	62	76	75	57	71
280 S-2	75	76	90	66	80	64	78	90	59	73
280 M-2	90	76	90	66	80	64	78	110	59	73
315 S-2	110	76	91	66	81	64	79	132	60	75
315 M-2	132	76	91	66	81	64	79	160	60	75
315 L ₁ -2	160	76	91	66	81	64	79	200	60	75
315 L ₂ -2	200	76	91	66	81	64	79	250	60	75
315 L ₃ -2	250	76	91	66	81	64	79	315	60	75
355 L ₁ -2	315	81	96	68	84	66	82	355	60	76
355 L ₂ -2	355	81	96	68	84	66	82	400	60	76
355 L ₃ -2	400	81	96	68	84	66	82	-	-	-
ns = 1500 rpm, 2p = 4										
132 S ₁ -4	5,5	57	70	55	68	-	-	-	-	-
132 S ₂ -4	7,5	57	70	55	68	-	-	-	-	-
160 M-4	11	62	75	59	69	-	-	-	-	-
160 L-4	15	62	75	59	69	-	-	-	-	-
180 M-4	18,5	60	73	57	70	56	69	22	51	64
180 L-4	22	60	73	57	70	56	69	27	51	64
200 L-4	30	61	75	58	72	57	71	37	51	65
225 S-4	37	63	77	59	73	58	72	45	52	66
225 M-4	45	63	77	59	73	58	72	55	52	66
250 M-4	55	65	79	64	78	63	77	70	56	70
280 S-4	75	68	82	66	80	65	79	90	58	72
280 M-4	90	68	82	66	80	65	79	110	58	72
315 S-4	110	69	84	66	81	65	80	132	57	72
315 M-4	132	69	84	66	81	65	80	160	57	72
315 L ₁ -4	160	69	84	66	81	65	80	200	57	72
315 L ₂ -4	200	69	84	66	81	65	80	250	57	72
315 L ₃ -4	250	69	84	66	81	65	80	315	57	72
355 L ₁ -4	315	72	88	68	84	67	83	355	58	74
355 L ₂ -4	355	72	88	68	84	67	83	400	58	74
355 L ₃ -4	400	72	88	68	84	67	83	400	58	74

Special-Purpose Motors

34

On-Deck installation with shipping classification

Electrical machines installed on ships - especially on the top deck -, on oil rigs, in port facilities and in sewage treatment plants, must be able to withstand a high level of corrosive attack from the humid, saline atmosphere and occasional flooding. The same applies to fan motors in cooling systems and cooling towers.

Humidity is especially damaging to motors where extreme temperature changes occur, for example direct sunshine in the day followed by low temperatures at night.

For these areas of application, motors have been developed by ATB in special corrosion-resistant implementation. In addition to the many features of the industrial motor series, such as

- long life
- long maintenance intervals
- high efficiency and performance
- low sound pollution of the environment

These motors incorporate a series of measures designed to protect the surface, the seals and the ventilation system from the effects of water and chemical attack.

Motors intended for on-board or offshore installation are supplied with the required acceptance certificates as specified by the relevant classification authorities. They also comply with the specifications of oil companies.

These special-purpose motors are certified for use in maritime applications by Germanischer Lloyd, Nippon Kaiji Kyobai, Lloyd's Register. The special suitability for the maritime sector is certified through this.

An anti-condensation heater can be fitted to the motors in order to prevent excessive condensation on the stator winding due to high temperature fluctuations and load changes (e.g. during intermittent use).

This heater takes the form of heating strips attached to the winding heads.

Anti-condensation heating is also possible through feeding of the stator coil with a reduced voltage via two terminals.

In addition, the windings can be protected by encapsulating them. This method can be used instead of an anti-condensation heater.

Special-purpose variants for on-deck installation

Components	Measures
Protection type of motor and terminal box	IP56 tested to DIN EN 60 034, Part 5, VDE 530 Part 5
Shafts	The motor shafts are made from high-grade steel.
Shaft area seals Drive end and non-drive end	For frame sizes up to 160, radial shaft seals to DIN 3760 are used From frame size 180, motors are fitted with a combined sealing system, consisting of a radial and an axial seal
Fan cowl, canopy	Frame sizes 71 to 160 have reinforced fan cowls, Material thickness ≥ 2 mm From frame size 180 fan cowls for all construction types with canopy and baffle plate material thickness ≤ 3 mm
Fan	Fan in saltwater-resistant aluminium alloy or steel
Fastening screws	Stainless steel screws (A 2-70) used throughout
Cable entry	If supplied with cable entry, metal cable entries certified to DIN EN 50 014 are used.
Paintwork	Special paintwork with zinc primer

Bearing seals

Effective outer bearing seals made from saltwater-resistant materials prevent penetration of water into the bearing area during downtime and operation. Above frame size 180, a double seal is used, which consists of a radial seal and an axial seal. A sealing grease filling between roller bearing and external seal additionally protects the bearings against the ingress of dirt and moisture.

Flameproof shaft bushings

The shaft is made from high-grade steel. This prevents corrosion of the shaft in the gap areas which are a key to maintaining the motor's flameproof properties.

Screwed connections

All screws used on the housing, bearing covers and the terminal box are made from stainless steel. Teflon-coated screws are available on request. A special-purpose anti-corrosion grease is applied to all screws before they are fitted.

Reinforced fan cowl

From frame size 71 and above the fan cowls are reinforced. Above frame size 180, a canopy and a labyrinth plate arranged around the air intake are also fitted to protect the fan from sudden ingress of large amounts of water, e.g. during high seas.

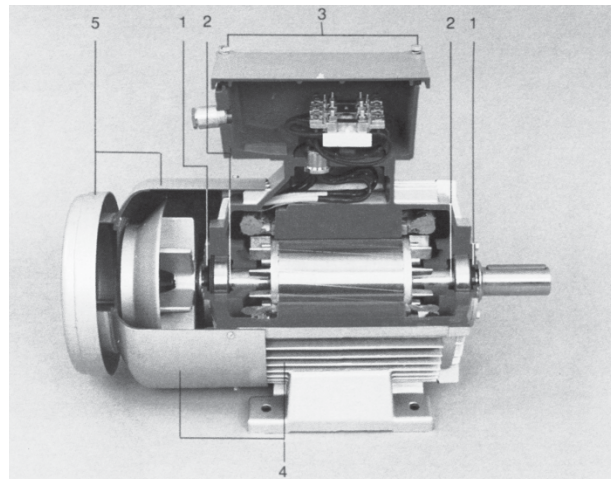

1. Saltwater-resistant double seals
2. Corrosion-resistant shaft bushings
3. High-grade steel fastening screws
4. Saltwater-resistant multi-layer special coating
5. Reinforced fan cowl with canopy and baffle plate to protect fan in high seas



Special-Purpose Motors

36

Flexi Mount Motor

The Flexi Mount Motor was designed to simplify warehouse stock keeping through the universal employment of one type of motor.

The illustration shows how the flanges, the feet, the lugs and the protective cowl can be replaced. Thus all possible versions according to EN 60034-7 can be achieved from a basic motor.

All these work operations are feasible without opening the flameproof chamber. No authorization from any authority is necessary for restarting operation. The conversion is reversible, so that one motor after another can be employed at different locations.

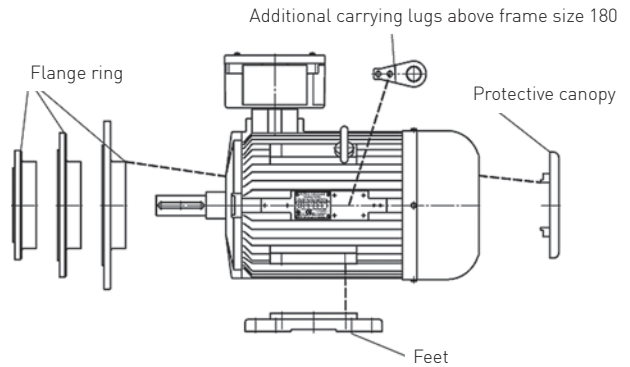

Available flanges

Frame size	FF Flange Ø in mm ¹⁾												FT Flange Ø in mm ¹⁾							
	100	115	130	165	215	265	300	350	400	500	600	740	65	75	85	100	115	130	165	
	A Flange Ø in mm ²⁾												C Flange Ø in mm ²⁾							
	120	140	160	200	250	300	350	400	450	550	660	800	80	90	105	120	140	160	200	
63	0	X	0	0	0	0	0	0	0	0	0	0	0	X	0	X	0	0	0	
71	0	0	X	0	0	0	0	0	0	0	0	0	0	0	X	0	X	0	0	
80	0	0	0	X	0	0	0	0	0	0	0	0	0	0	0	X	0	X	0	
90	-	0	0	X	0	0	0	0	0	0	0	0			0	0	X	X	0	
100			0	0	X	0	0	0	0	0	0	0					0	X	X	
112			0	0	X	0	0	0	0	0	0	0						0	X	
132					0	X	0	0	0	0	0	0						0	0	
160					0	0	X	0	0	0	0	0								
180						0	X	0	0	0	0	0								
200							0	X	0	0	0	0								
225								0	X	0	0	0								
250										X	0	0								
280										X	0	0								
315											X	0								
355												X								

X = Standard

0 = Special flange (extra cost option)

All other versions require an intermediate ring (extra cost option).

Note

1) New designation to EN 50347

2) Old designation to DIN 42948

Motors with attachments

ATB motors are designed to cover a wide range of applications. To meet the special requirements associated with each of these uses, a series of attachments has been developed.

The standard attachment and use of brakes, tacho generators and pulse generators, as well as reverse running locks, enables you to savings on costs. With the installation of one component, different combinations of special-purpose versions can be achieved.

**Tachogenerator
Design series ...R****Application**

Actual-value sensors are employed for the electrical remote measurement, as well as regulation of the motor speed. These devices convert the input variable "rotation speed" into an analog or digital electric signal.

From frame size 80, this unit can be mounted on or installed directly in (frame size 80–132) the motor (incremental sensor).

Design

All attachments are mounted on the reinforced fan cowl.

The explosion-proof tacho generators are connected to the motor shaft by means of a backlash-free coupling.

In frame sizes 80–132, a pulse generator can be installed in the flameproof motor housing.

Connection

Attached-mounted devices are connected in a separate terminal box.

In case of motors with integrated sensor, the connection is implemented in the main terminal box.

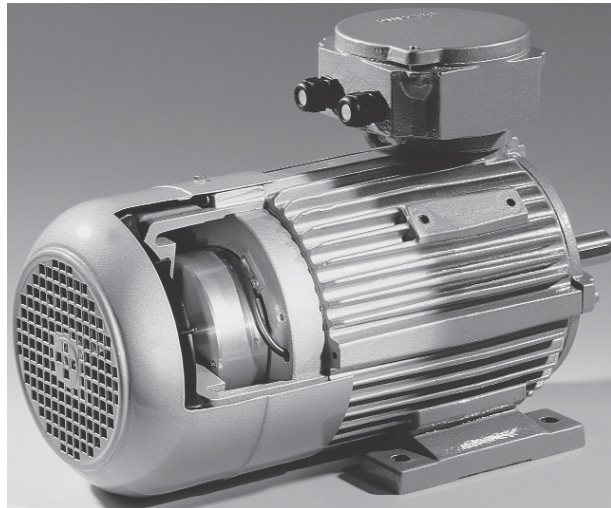

Motor with integrated incremental sensor

Special-Purpose Motors

38

Built-on and built-in equipment,
reverse-running lock, direct gearing mounting

Reverse-running lock

Application

In the operation of conveying systems or pumps, the reverse-running lock prevents reverse-running after the shutdown of the motor.

Version

For the frame sizes 80 to 100, locking ball bearing can be used. This is especially recommended if this version should be combined with another attachment. Although the locking bodies are integrated into the bearings, the load-bearing capacity of the bearings is reduced only slightly compared to normal bearings. Since the locking bodies rub against the raceways, however, the maximum rotation speed is limited to 1500 rpm and a reduced bearing service life is to be expected.

From frame size 90, the reverse-running lock can also be used mounted onto a reinforced fan cowl directly on the extended motor shaft. This reverse-running lock is constructed so that the clamping pieces lift off the stationary outer ring due to the centrifugal force, with retention of the minimum speed. No additional frictional forces or noise are therefore generated with this version.

Direct transmission mounting

The motors in requiring "oil proof flanges" can be fitted directly to transmission units. The shafts of these motors are sealed with radial seal rings to DIN 3760. The available flanges are listed in the table on page 36.

The seal rings must be spray or mist lubricated.

The motors to frame size 450 have the fixed bearing on the drive side, in order to limit the thermal expansion of the rotor to the transmission.

Reverse-running lock data

Frame size	Reverse-running lock drive-end type	Rated torque [Nm]	Service life at 1500 rpm [h]
80	ZZ 6204 L	32	3800
90	FC 6205	40	5600
100	ZZ 6206 M	110	1900

Frame size	Reverse-running lock Type	Rated torque [Nm]	Lift-off speed [rpm]
90	FXM 31-17 DX	100	890
100	FXM 38-17 DX	150	860
112			
132			
160	FXM 66-25 DX	800	700
180			
200	FXM 86-25 DX	1350	630
225			
280			

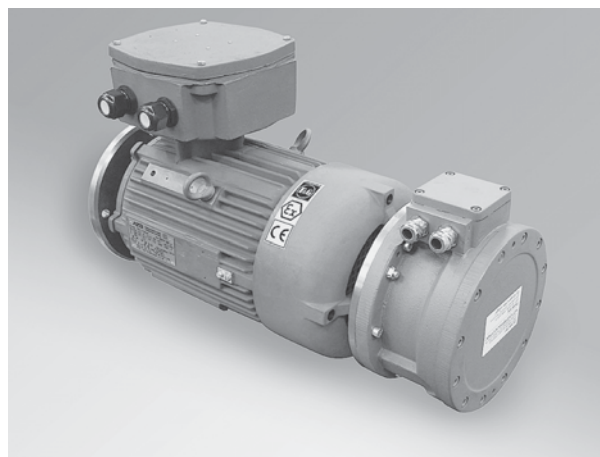

Motor with fitted-on brake

Design series CD...S

Construction type

From frame size 80 the brake is mounted in a flameproof enclosure onto a reinforced fan cowl as separately certified equipment

The brake is available in the torque range 10–270 Nm in Version II 2G EEx de IIC T5 and II 2D IP 67 T100 °C. Rated voltage to 400 VAC. Connection to its own explosion-protected Ex e terminal box.

A 400 Nm locking brake is available in Version II 2 G/D EEx d IIC T4 IP 65 T 120 °C. Rated voltage to 207 VDC. For rated voltage to 400 VAC (a separate rectifier is required). The rectifier is not explosion-proof. It can be housed either in a flameproof enclosed terminal box on the motor or it is to be installed in the switch gear room center in the non-explosion-hazardous area.

The cable running directly from the brake can be routed either into the main terminal box of the motor, into an additional terminal box or directly into the switch gear room.

Switching

Implementation 10–270 Nm:

The spring-loaded brake can be operated from both the AC and the DC side. The standard version of the brake is fitted with a rectifier and a bridge across terminals 3 and 4 (see picture top left). For DC-side operation, the bridge must be removed and an appropriate contact fitted.

Protective devices

Implementation 10–270 Nm:

For motor protection according to DIN EN 60 079-14, VDE 0165 against excess temperature due to overload, the winding temperature is monitored with PTC thermistor temperature sensors.

Three series-connected PTC thermistor temperature sensors are fitted to the winding head (warmest point) of the three phases of the stator winding.

For device protection, the brake is equipped with two thermo switches and an optional micro switch.

The thermo switches connected in series with the micro switch interrupt the circuit as soon as the spring-loaded brake reaches an inadmissible temperature. Once it has cooled down, the brake is fully functional again.

The integral micro switch is used for switching the control circuit and prevents the motor from starting while the brake is applied.

Version 400 Nm:

This brake is not thermally monitored and thus can be employed as a locking brake only. A micro switch is supplied for switching monitoring.

Operating data will be found on page 84.

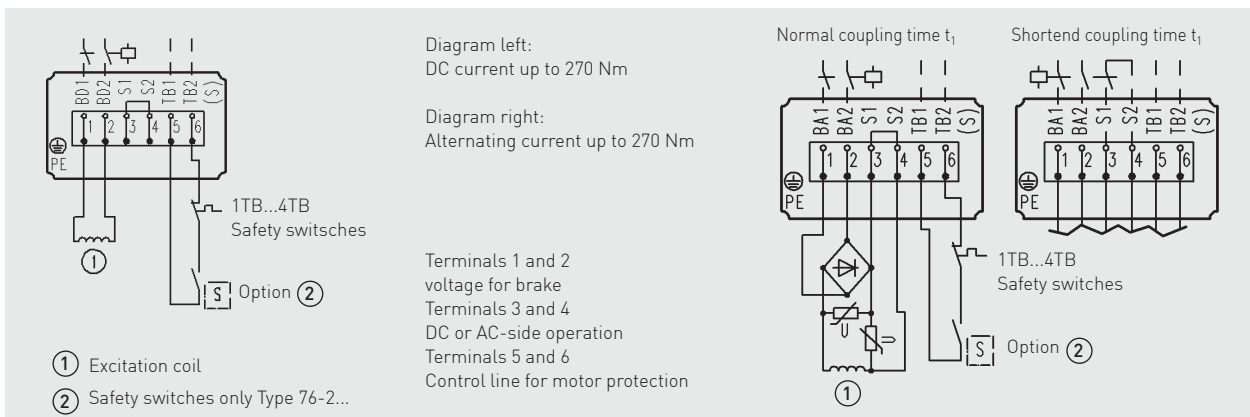

Special-Purpose Motors

40

Brake motors with integral brake

Design series BD...B

Construction type

In frame sizes 80 - 132 motors, the brake is enclosed in a flameproof adapter housing, which is mounted on the non-drive end of the motor to form a single unit. It is protected to II 2G/D EEx d(e) IIB + H₂ T4 T120 °C IP65. The system is completely maintenance free for the lifespan of the brake linings.

Connection

The brake coil is energized by a silicon rectifier fitted inside the flameproof enclosure. The brake can be controlled from the AC or DC side.

For operation from the DC side, a brake coil connection is fed into the terminal box. In addition, the motor is equipped with a protective resistor. If this layout is to be used for AC brake operation, a connection is not required in the terminal box. Instead, the connection shown in the circuit diagram must be established. On pole-changing and rectifier-supplied motors, the brake coil must be supplied from an external power source.

Motor voltages

Frame sizes 80–112: 230 V to 690 V

Frame sizes 132: 400 V to 690 V

Brake voltages

Brake coil data see page 86.

Non-standard voltages are available at extra cost.

Protective devices

To protect the motor from excessive temperatures to DIN EN 60079-14 VDE 0165, three series-connected PTC thermistor temperature sensors are installed in the winding head (warmest point) of the three stator winding phases.

In addition, each motor is equipped with a PTC thermistor temperature sensor in the brake coil and on the non-drive-end shield. All temperature sensors are connected in series and protect the motor and brake from overloads and excess temperature.

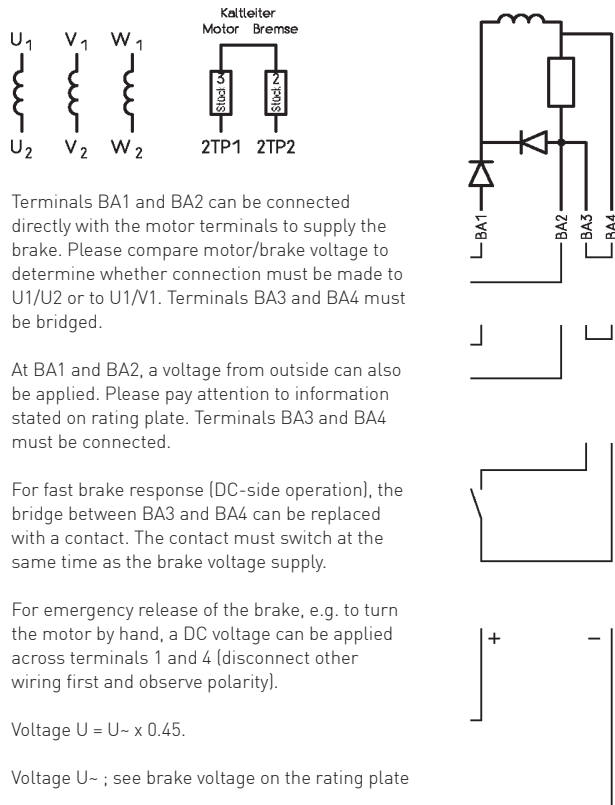
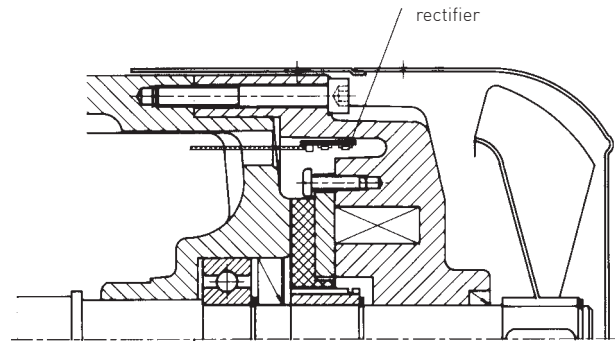

Terminals BA1 and BA2 can be connected directly with the motor terminals to supply the brake. Please compare motor/brake voltage to determine whether connection must be made to U₁/U₂ or to U₁/V₁. Terminals BA3 and BA4 must be bridged.

At BA1 and BA2, a voltage from outside can also be applied. Please pay attention to information stated on rating plate. Terminals BA3 and BA4 must be connected.

For fast brake response [DC-side operation], the bridge between BA3 and BA4 can be replaced with a contact. The contact must switch at the same time as the brake voltage supply.

For emergency release of the brake, e.g. to turn the motor by hand, a DC voltage can be applied across terminals 1 and 4 (disconnect other wiring first and observe polarity).

Voltage $U = U_{\sim} \times 0.45$.

Voltage U_{\sim} ; see brake voltage on the rating plate

Operating data

The electrical motor data not listed in the operating data (Page 82), in particular the torque values and characteristics, can be determined from the specifications for three-phase motors (see page 55 onwards).

Switching times, over travel

The table on the next page shows nominal brake response and recovery times and revolutions of over travel on power-off. The values were obtained in series testing.

Switching times, overtravel

Frame size BD ... B	Response times		Recovery time t_2 [ms]	Overtravel ¹⁾	
	AC-side operation $t_{11} \sim$ [ms]	DC-side operation $t_{11} =$ [ms]		AC-side operation Revo- lutions	DC-side operation Revo- lutions
80K-2	150	30	90	10	2
80L-2	150	30	90	11	2
90L ₁ -2	250	45	110	15	2
90L ₂ -2	250	45	110	16	3
100L-2	300	50	150	19	3
112M-2	300	50	150	24	3
132S ₁ -2	350	50	230	25	4
132S ₂ -2	350	90	230	27	4
80K-4	150	30	90	4	1
80L-4	150	30	90	4	1
90L ₁ -4	250	45	110	5	1
90L ₂ -4	250	45	110	5	1
100L ₁ -4	300	50	150	6	1
100L ₂ -4	300	50	150	7	1
112M-4	300	50	170	11	1
132S-4	350	90	230	12	2
132M-4	350	90	230	13	2
80K-6	150	30	90	3	1
80L-6	150	30	90	3	1
90L ₁ -6	250	45	110	4	1
90L ₂ -6	250	45	110	4	1
100L-6	300	50	150	6	1
112M-6	300	50	150	7	1
132S-6	350	90	230	7	1
132M ₁ -6	350	90	230	8	2
132M ₂ -6	350	90	230	8	2
80K-8	150	30	90	2	1
80L-8	150	30	90	2	1
90L ₁ -8	250	45	110	3	1
90L ₂ -8	250	45	110	3	1
100L ₁ -8	300	50	150	3	1
100L ₂ -8	300	50	150	4	1
112M-8	300	50	150	6	1
132S-8	350	90	230	7	2
132M-8	350	90	230	7	2

Note

1) The over travel of the motors was measured without additional centrifugal masses.

Brake torque, wear values

Through a combination of different coupling springs and brake disks, the braking torque's can be set adjusted.

Torque characteristic¹⁾, Abrasion values

Type BD...B	Rated Torque M_2 [Nm]	Abrasion value Q_r [J]		Brake disk Thickness new [mm]
		$Q_{r 0,1}$	$Q_{r ges.}$	
80	8	65×10^6	162×10^6	6,9
	10 ²⁾	65×10^6	162×10^6	6,9
	11,5	13×10^6	13×10^6	6,9
	16	13×10^6	13×10^6	6,9
90	16	100×10^6	500×10^6	8
	20 ²⁾	100×10^6	500×10^6	8
	23	20×10^6	20×10^6	8
	32	20×10^6	20×10^6	8
100	32	130×10^6	600×10^6	10,4
	40	130×10^6	600×10^6	10,4
	46 ²⁾	30×10^6	45×10^6	10,4
	64	30×10^6	45×10^6	10,4
112	32	130×10^6	600×10^6	10,4
	40	130×10^6	600×10^6	10,4
	46 ²⁾	30×10^6	45×10^6	10,4
	64	30×10^6	45×10^6	10,4
132	60	130×10^6	700×10^6	11,15
	75	130×10^6	700×10^6	11,15
	86 ²⁾	65×10^6	130×10^6	11,15
	100	65×10^6	130×10^6	11,15

Note

1) Tolerance -20 %/+40 % at 1m/s friction speed
2) Standard torque

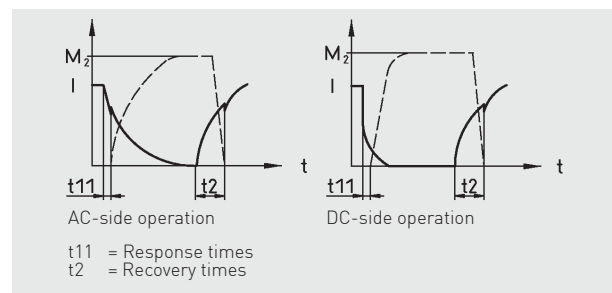

The possible friction work Q_r can be calculated according to the following formulae. Please take the wear limits from the table.

$$Q_r = \frac{J \times n^2}{182,4} \times \frac{M_2}{M_v} \quad [J]$$

$$M_v = M_2 + (-) * M_L \quad [Nm]$$

Q_r [J] = Existing friction work per braking operation

$Q_{r 0,1}$ [J] = Friction work per 0.1 mm wear

$Q_{r ges.}$ [J] = Friction work to brake disk change

J [kgm²] = Moment of inertia

n [min⁻¹] = Rotation speed

M_2 [Nm] = Rated torque

M_v [Nm] = Retardation torque

M_L [Nm] = Load moment

* Sign in brackets (-) applies in case of load braking downwards

Three-phase AC Asynchronous Motors with Integrated Frequency Inverter

42

Compact drives

Design series CD...I

Compact drives in explosion-protection rating II 2 G/D EEx de IIC T4 T120 °C IP65 consist of a flameproof ATB motor, type CD ...I, with a frequency inverter attached, also flameproof enclosed, type CEIGL. It is suitable for rotation-speed-controlled applications in explosion-hazard areas of zones 1 and 21.

Frequency range

The certification includes a frequency range from 2 to 100 Hz. Compact drives are therefore suited for use in drive solutions up to 6000 rpm. Above 50 Hz, the drive is designed for operation in the field-shunting range, i.e. with constant power.

Monitoring

The thermal monitoring of motor and inverter is implemented through PTC thermistor temperature sensors. Optionally a certified thermistor tripping device, as well as an input contactor, are installed in the inverter casing. With this, the compact drive can offer the required switching-technical prerequisites for employment with galvanic separation in the fault case in an explosion-hazardous area, without additional switching devices.

Frequency inverter

A full-value, commercially-available frequency inverter, type 8200vector, from the LENZE company, is used. This operates the motor with field-oriented vector regulation and a clock frequency of 4 kHz. Very good running and regulation characteristics result over the entire rotation speed and torque range. The adaptation of the inverter to the motor with the recording of the motor parameters, as well as the base parameterization of the frequency inverter, is implemented during the final inspection and testing.

Control

The control of the compact drive is implemented, according to specification of the operator, concerning different, exchangeable function modules of the frequency inverter. These function modules are available for bus systems, such as PROFIBUS-DP, interbus, CAN-Bus or as I/O-Module for conventional control over analog set point value and ON/OFF contacts.

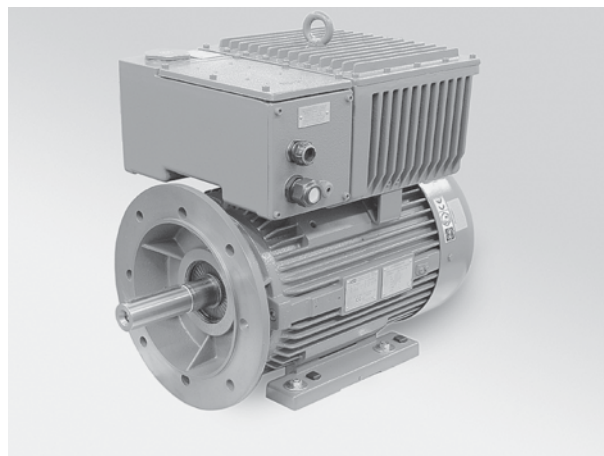

Compact Drive Type CD 132 M-4 I

Technical data compact drive

Ignition protection type	Flameproof enclosure II 2 G EEx de IIC T4 II 2 D EEx de IIC T4 IP65 T120 °C
Construction sample certificate Inverter housing	PTB 01 ATEX 1082
Frame sizes	80 to 160
Connection voltage	380 to 500 V \pm 10 %, 50/60 Hz
Load range	0.55 to 11 kW
Maximum current	150 % I_n for 60 s in 10 min
Leakage current to PE (to EN 50178)	> 3,5 mA Fixed installation required, PE double implemented
Output frequency	2 to 50/100 Hz
Frequency resolution absolute	0.02 Hz
Protection insulation of control circuits	Safe isolation PELV to EN 50178
EMC	Maintenance of requirements to EN 61800-3/A11

EMC

To limit the mains system reactions, the inverter is equipped with a line reactor integrated into the flameproof casing and possesses an EMC filter for grounded mains network. Thus the compact drive fulfills the prerequisites of the specifications of the EMC Directive 89/336/EU, as well as the low-voltage Directive 73/23/EU, i.e. conformity with DIN EN 61800-3/A11 and compliance of the limit value Class A according to DIN EN 55011.

Connections

The connections of the supply voltage and control are implemented in an explosion-protection Ex e terminal housing of the inverter casing. A manual terminal with keyboard and LCD display is available for display of operating data, parameters and diagnostics. This "key pad" is connected to the frequency inverter via a plug in the explosion-protection Ex e terminal compartment. However, it is not explosion-proof and is thus provided for short-term operational startup only.

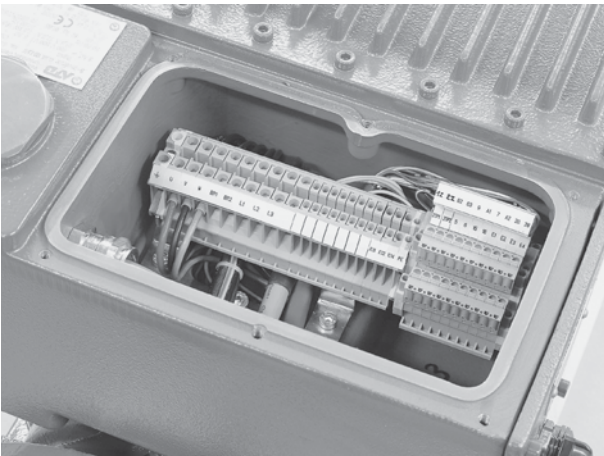

Integrated frequency inverter

Entries of the mains supply lines with compact drives

Frame size	80	90	100	112	132	160
Thread	2x M25x1,5 1x M16x1,5				1x M32x1,5 1x M25x1,5 1x M16x1,5	
for cable outer Ø mm	8-17 6-11				12-21 8-17 6-11	

Through the compact connection of a motor with frequency inverter, for employment in almost all explosion-hazardous areas, with the following advantages for the user:

- With certification according to ATEX 95, employment is possible in the zones 1 and 21 throughout the whole of Europe – without further national acceptances.
- Simplified planning process
- No additional projecting of control cabinet and switching system
- Cost reduction through short feed to the motor, an implementation with shielded line is not necessary.
- Feed to the compact drive without EMC problems, through the employment of network and EMC filter on the motor.
- Lower number of different part types and thus cost reduction through utilization of a inverter wide-voltage device for 400 V to 500 V mains voltage.
- No version limitation, since an ATB explosion-protection motor Ex d in standard-type implementation is employed.
- The version is possible as a universal chemical-industrial motor.

You can find tables with the operating data on page 87.

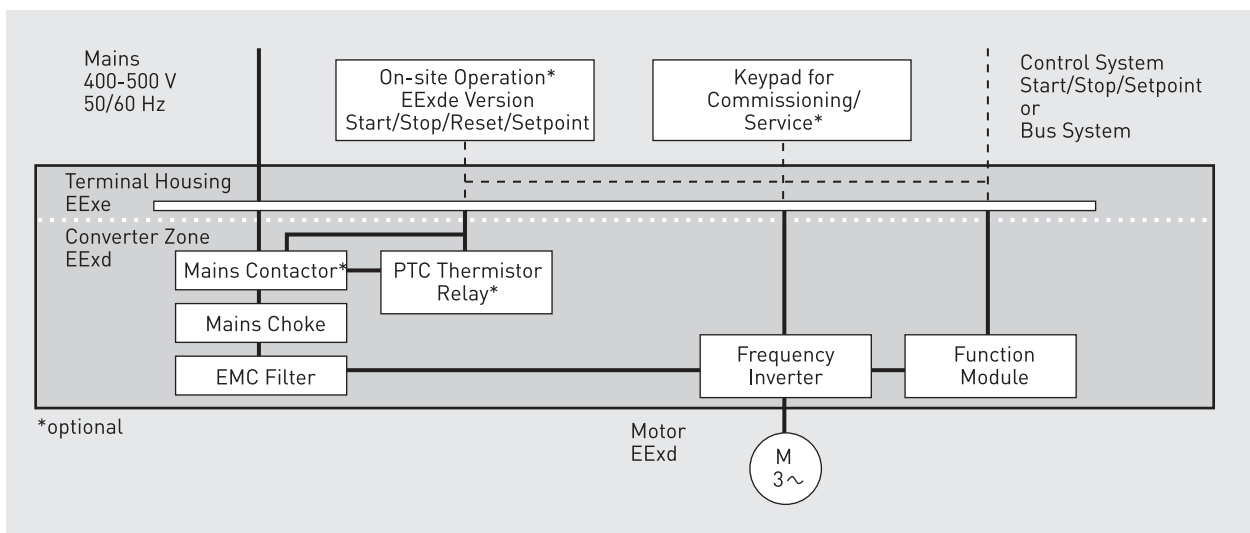

Block diagram

Special-Design Motors

44

High-voltage motors

Design series CD...H

The high-voltage three-phase motors are explosion-proof in the explosion protection rating "flameproof enclosure", in accordance with DIN EN 50 014, VDE 0170/0171 for the Groups IIC and the temperature classes T3 to T6.

Winding

According to design, round-wire fed-in windings or conventional form-wound coils are employed. The thermal application corresponds to the heat class B. In special cases, the limit is only slightly exceeded for class F.

Connection

The connection of the motors is implemented optionally via terminal boxes designed for rated voltage 6.6 kV of the explosion protection rating "increased safety" or "flameproof enclosure". The box is mounted above in the standard arrangement. Side versions are possible. The boxes can be rotated through $4 \times 90^\circ$ in each case, in order to enable connection from all directions. This is possible without rotating the connecting terminals. On request, the neutral point is located in a second terminal box. Main boxes and neutral-point boxes are then arranged at intermediate connections enclosed flameproof, i.e. mounted on the motor support.

Through replacement of the terminals between the two boxes, there is also the possibility of a voltage-selection capability in this case.

Bearings

All high-voltage motors are already equipped with an insulated bearing on the non-drive end in the standard version.

Version

- Series CD 355 ...H to CDS 450 ...H
- Acceptance for category II 2 G
- Employment in zone 1 and 2
- Temperature class T3 to T6
- Power range from 160 to approx. 700 kW (with reference to 1500 rpm)
- Rated voltage from 3 kV to 6.6 kV
- 50 Hz pole-no.: $2p = 2-8$ such as at
- 60 Hz pole-no.: $2p = 4-8$
- Self-cooling (IC411) with bi- or unidirectional fan
- Customer-specific special-purpose versions

Operating data will be found on page 89.



High-voltage motor

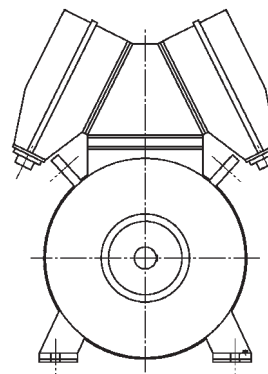

Motor with two HV boxes

Rated voltage

The explosion-proof, flameproof three-phase asynchronous motors are generally available for standard voltages to DIN IEC 38 (5.87) with the following rated voltages:

Rated voltage

50 Hz	230/400 V	Delta/Star ¹⁾
	400/690 V	Delta/Star ²⁾
	500 V	Star ³⁾
60 Hz	500 V	Delta
	266/460 V	Delta/Star
	460 V	Delta

Note

1) standard up to frame size 112

2) standard up to frame size 132

3) standard

Voltage tolerances according to EN 60034-1. Special voltages on request.

Insulation

All materials used for insulation of the winding and the winding end leads comply with insulation class F.

Utilization of the over temperature limit in continuous operation S1 corresponds to thermal class B for constant-speed motors.

Motors of the series ...X with increased performance and pole-switching motors are utilized in accordance with thermal class F.

The limit over temperature for the winding insulated to thermal class F, according to VDE 0530, is 105 K at an ambient temperature of RT 40°C.

In case of utilization to thermal class B, the permissible winding temperature increase, according to VDE 0530, is 80 K at an ambient temperature of RT 40°C.

The high-grade materials used for the insulation system provide optimum protection against the influence of aggressive gases, vapors, dust oil and air humidity.

Winding end leads

The motors have six winding end leads U1, V1, W1, U2, V2 and W2. In case of motors with high output and delta circuit connection with a rated current of 400 A or higher, two parallel mains supply lines are required in each case, because the connection terminals have a current limit.

For delta connection from 690 A and star connection from 400 A, rated current duplicate winding ends are provided. The three motor connections to the six terminals are U, U; V, V; and W, W. Here also, two parallel mains connections are needed in each case.

Pole-changing motors

Pole-changing motors have the same design and dimensions as the constant-speed three-phase asynchronous motors. The special features of the pole-changing motors are listed below.

Frame sizes

80–355	4/2 pole
90–355	8/4 pole
90–355	6/4 pole

Other pole combinations and frame sizes are available on request.

In the standard version the pole-changing motors are designed for about same torque (see pp. 77). For motors with a Dahlander pole-changing circuit, this corresponds of the circuit Δ/YY .

For special applications of e.g. fan, centrifugal pumps etc., the pole-changing motors are designed for approximately quadratic torque (see pp. 80). For motors with a Dahlander pole-changing circuit, this corresponds of the circuit Y/YY . These motors are supplied for the standard rated voltages 400, 500 and 690 volts for a rated frequency of 50 Hz. With special windings, these motors can also be implemented with rating for any voltage within the voltage range 400–690 volts (additional certification may be required). Other voltages and frequencies are available on request. The thermal utilization of the motors corresponds to the employed heat class "F".

Insulation system

Heat class to VDE 0530	Insulation system Wire/Surface insulation	Impregnation
F	Enamelled wires to DIN 46 416 Part 5 Grade 2, Temperature index 200 surface insulation on basis of polyester and aromatic polyamide	Impregnating resins to heat class F to VDE 0360 Teil 2 applied in continuous operation from frame size 225 im hardened by rolling

Protective device

According to DIN EN 60079-14 VDE 0165, all poles of the motors must be protected with motor protection switches, or equivalent protective equipment, against excess heat buildup caused by overload.

We use a winding temperature monitoring system using PTC thermistor temperature sensors. All motors from frame size 63 can be equipped with this protective facility as sole or additional motor protection.

All motors can be implemented with PTC thermistor temperature sensor as additional motor protection, as well as the motor circuit-breaker.

This protection method is specified in operating modes other than S1, such as intermittent operation, switching operation, long starting times, etc. It also provides protection in case of reduced cooling airflow and excessive ambient temperature. Motors certified for operating modes S1 to S7, as well as S9 and S10, with PTC thermistor temperature sensors as sole protection, are therefore approved for use with frequency inverters (operating data see pages 59, 61, 63, 65).

Temperature sensor protection consists of three series-connected PTC thermistors fitted to the winding head (warmest point) of the three phases of the stator winding. In case of motors with up to 3 separate windings, 3 temperature sensors are employed in each case; all sensors are connected in series. The construction designations of the thermistor terminals in the terminal box are „TP1“ and „TP2“.

The PTC's have to be connected to an certified PTC-tripping-device which is marked II(2) G.

Versions with additional temperature sensors, e.g. for temperature alarms, are available on request.

Heating elements

Heating elements will be used to avoid anticondensation or to protect the motor against low-temperatures below $-20\text{ }^{\circ}\text{C}$. The heating-up can be achieved via the motor winding or strip-type heaters.

The anti-condensation heating via the motor winding is achieved by an reduced AC voltage via terminals U1 and V1. The heating voltage in table (page 47) relate to 50 and 60 Hz in star or delta circuit layout and to all frame sizes of the respective frame sizes for pole numbers 2 pole to 8 pole. The stated output is a minimum value, i.e. the next highest-rated output must be used as the transformer rating. For precise matching, the transformer must have voltage taps of $\pm 10\%$. Provisions must be made to ensure that motor voltage and heating voltage cannot be applied at the same time.

Optionally, anti-condensation heating can be implemented in the form of strip-type heaters fitted to the winding heads (extra cost).

Supply voltage $230\text{ V} \pm 10\%$ or on request.
Frequency 45–65 Hz.
Terminals „HE1“ and „HE2“.

The heater itself is not explosion-proof. It must not be used to heat up the motor from temperatures less than $-20\text{ }^{\circ}\text{C}$ to at least $-20\text{ }^{\circ}\text{C}$, because at motor housing temperatures below $-20\text{ }^{\circ}\text{C}$ the flameproof enclosure will lose the approval and the motor must not be used at these low temperatures. The heating it is only suitable for preventing a drop of the motor temperature to below $-20\text{ }^{\circ}\text{C}$ in the standstill condition.

If heating-up is not appreciated, we can offer a special designed motor execution for use in areas down to $-55\text{ }^{\circ}\text{C}$ without heaters (see page 15).

The heating power is shown in the table on page 47.

Data of heating elements

Frame size	For prevention of condensation with heating strip over motor winding							For protection at temperatures below -20 °C (to -40 °C) ²⁾ with heating strip over motor winding						
	Output [W]	Output [VA]	Heating voltage at motor rated voltage					Output [W]	Output [VA]	Heating voltage at motor rated voltage				
			230 V [V]	400 V [V]	460 V [V]	500 V [V]	690 V [V]			230 V [V]	400 V [V]	460 V [V]	500 V [V]	690 V [V]
63	20	25	45	75	90	100	130	35	65	70	120	140	160	210
71	20	40	35	65	75	85	110	35	100	60	100	120	135	175
80	24	50	30	55	65	75	100	46	125	50	90	100	115	155
90	24	70	25	45	50	60	80	46	175	40	70	80	95	125
100	24	100	25	40	50	55	70	76	250	40	65	75	85	115
112	24	150	20	40	45	50	65	76	375	35	60	70	80	105
132	46	200	20	35	40	45	60	120	500	30	55	65	70	90
160	46	300	17	30	35	40	50	120	750	25	45	55	60	80
180	76	400	15	25	30	35	45	240	1000	25	40	50	55	70
200	76	500	13	20	25	30	40	240	1250	20	35	40	45	60
225	120	650	13	20	25	30	40	350	1650	20	35	40	45	60
250	120	800		20	25	30	35	350	2000		35	40	45	60
280	240	1200		20	20	25	30	700	3000		30	35	40	50
315	240	1600		17	20	25	30	700	4000		30	35	40	50
355	350	2300		15	18	20	25	1000	5700		25	28	30	40
400	480	3000		12	14	16	20	¹⁾ 7500			20	22	25	30
450	700	4000		10	12	13	17	¹⁾ 10000			15	18	20	20

Note

1) On request

2) Outputs for temperatures to -55 °C on request

Electrical Version

48

Connection Diagram

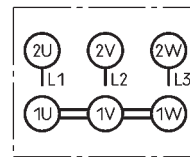
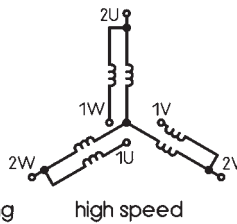
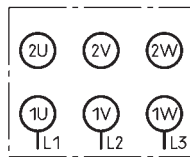
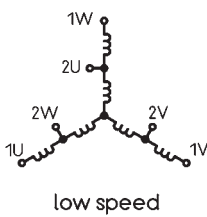
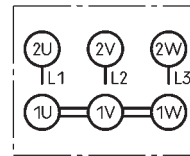
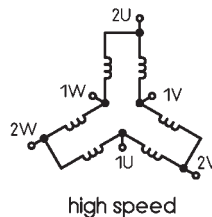
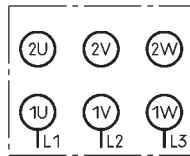
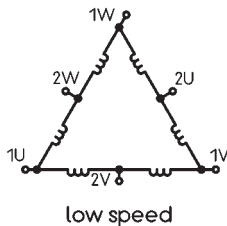
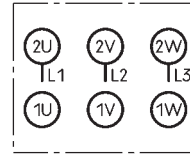
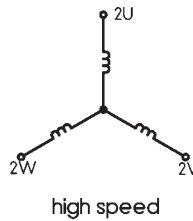
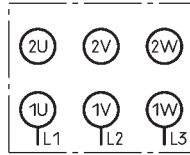
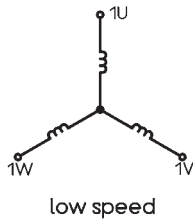
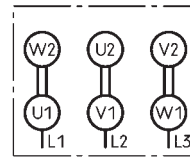
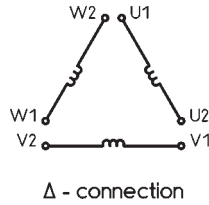
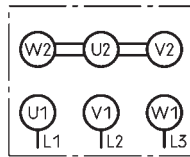
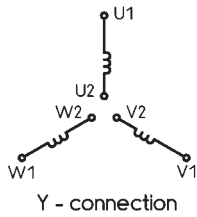

1 TP 1 - 1 TP 2	PTC-thermistor warning alarm	U>2.5V not allowed	PTC-tripping-device marking II (2) G	terminal stud	
2 TP 1 - 2 TP 2	PTC-thermistor switching off ¹⁾				
1 R 1 - R 2	thermistor PT 100 / winding	thermistor PT 100 / bearing		thread size	tightening (Nm)
4 R 1 - 5 R 2		<i>d.e.</i>	<i>n.d.e.</i>	M4	1.2
				M5	2
				M6	3
				M8	6
				M10	10
1 HE 1 - 1 HE 2	space heater			M12	15.5
2 HE 1 - 2 HE 2				M16	30

Note

1) tripping device with Ex conformity mark necessary

Efficiency, power factor

The efficiency values and power factors listed in the tables apply to operation at rated output, rated voltage and rated frequency. The efficiency values have been determined in accordance with VDE 0530 Part 2, Section 9 (loss-summation method). Tolerances in accordance with EN 60034-1.

The efficiency and power factor values at partial load are listed on pages 66 and 67. These values apply to the rated output at 50 Hz.

Output, operating mode

The output values in the tables apply at rated voltage and rated speed in continuous operation S1, a coolant temperature up to 40 °C and an altitude of up to 1000 m above m.s.l.

For higher ambient temperatures and altitudes above 1000 meters, output reductions become necessary. These are listed in the tables below:

Coolant temperature [°C]	Reduction of the rated output to approx.	
40	100 %	see "Operating data"
45	94 %	
50	91 %	
55	88 %	
60	84 %	

Height above m.s.l. [m]	Reduction of the rated output to approx.	
1000	100 %	see "Operating data"
1500	97 %	
2000	94 %	

If, for installation above 1000 m above m.s.l., the coolant temperature is reduced according to the allocation as shown in the table below no power reduction is necessary. See also EN 60034-1.

Altitude of installation above m.s.l. [m]		Maximum Coolant temperature [°C]
0	to 1000	40
1000	1500	35
1500	2000	30

Additional testing is required for motors with a coolant temperature deviating from 40°C, at an installation altitude other than 1000 m above sea level and whose outputs differ from the standard version.

Special acceptance tests are also required for operating modes other than S1 according to EN 60034-1. When making an inquiry, please provide the relevant information as required by paragraphs 4 and 11 of these regulations.

A winding temperature monitoring system ensures optimum utilization of the motor, as well as overload protection (see page 46).

Overload, starting current

The motors can be overloaded in accordance with the requirements of EN 60034-1. At operating temperature, they can run for two minutes at 1.5 times their rated current without incurring damage and can take 1.6 times their rated torque for 15 seconds.

The over current relays, which must be fitted according to the code of practice for electrical apparatus in hazardous areas, allow only limited acceleration times. The resulting limited mass inertia moments are listed in the table on page 50. This means that up to 2x consecutive startups are possible up to frame size 315 and 1x startup from frame size 355.

In case of motors with winding temperature monitoring through PTC thermistor, the starting times mentioned on page 50 are achieved.

Motor Operating Characteristics to 690 V

50

Permissible start up times for air-cooled motors without brake, temperature class T4, protection through PTC thermistor temperature sensors

Starting current, apparent starting output

The values of the starting current as a multiple of the rated current indicated under operating data are measured variables from a type test sample. From the values of the starting current relationship, the ratio of the starting apparent power to the rated motor output results from the relationship

$$\frac{S_A}{P_2} = I_A/I_N \frac{1}{\eta \times \cos \varphi}$$

Torque

The motors have squirrel-cage rotors, whose cages are die-cast aluminum constructions, with 2 to 8 poles, on frame sizes 63 to 315 L2 and, in larger sizes, they are implemented as hard-soldered copper bar constructions for direct actuation. The starting and stalling torque's, expressed as multiples of the rated torque's, are listed in technical data tables. The specifications are type sample measured values.

If the voltage deviates from the rated value, torque's (starting torque, acceleration torque and stalling torque) change approximately as a function of the square of the voltage.

Direction of rotation

In general, the motors can rotate in both directions. Motors with self-driven axial-flow fan are an exception (series ...A, ... AR). These fans are bi-directional. The rotation direction is displayed through an arrow on the fan cowl. Certified circuit diagrams are supplied with the motors.

Permissible start up times

Rated output P_2 [kW]	2p = 2 Permissible starting time ¹⁾		2p = 4 Permissible starting time ¹⁾		2p = 6 Permissible starting time ¹⁾		2p = 8 Permissible starting time ¹⁾	
	Cold	Warm	Cold	Warm	Cold	Warm	Cold	Warm
	t [s]	t [s]	t [s]	t [s]	t [s]	t [s]	t [s]	t [s]
0,12	-	-	90	62	-	-	100	59
0,18	60	40	90	62	-	-	100	59
0,25	60	40	90	62	80	63	100	59
0,37	60	40	90	62	79	62	100	59
0,55	60	40	90	62	55	40	100	59
0,75	50	36	75	50	85	55	95	56
1,1	47	31	60	38	80	50	108	69
1,5	45	27	46	26	73	42	108	81
2,2	45	20	46	25	65	46	104	72
3	42	20	46	22	51	39	80	50
4	35	19	39	23	46	34	85	55
5,5	30	19	43	25	45	29	84	54
7,5	35	19	42	22	35	22	87	58
11	35	19	39	23	38	19	81	45
15	41	21	46	24	43	22	59	41
18,5	39	20	46	23	46	27	46	29
22	39	20	52	24	43	21	59	40
30	39	20	52	25	60	31	57	33
37	53	21	56	28	57	28	66	45
45	69	32	62	26	75	45	74	44
55	74	29	45	25	80	56	77	48
75	85	39	56	23	64	36	61	40
90	84	42	59	25	49	22	60	30
110	97	45	62	23	60	30	60	30
132	103	48	63	26	60	30	60	30
160	100	50	60	30	60	30	60	30
200	100	50	60	30	60	30	60	30
250	100	50	60	30	60	30	60	30
315	100	50	60	30	60	30	60	30
355	100	50	60	30	60	30	60	30
400	100	50	60	30	60	30	60	30
450	-	-	60	30	60	30	-	-

Note

1) These times can be achieved only with winding temperature monitoring with PTC thermistor temperature sensors.

Switching frequencies

For motors in standard version (temperature class T4), with use of the heat class "F" and winding temperature monitoring through PTC thermistors, the start-ups indicated in the table are admissible.

A distinction is made between:

1. Number of starts against constant load torque.
2. Number of starts against load torque rising to rated torque as a square of the speed.

The values given apply to inertia factor FI = 1, i.e. they do not take the external moment of inertia into account. External moments of inertia can be included using the FI factor according to the equation

$$S = \frac{S_{\text{Catalogue}}}{FI} \text{ [S/h]}$$

$$\text{mit } FI = \frac{J_{\text{Zus.}} + J_{\text{Mot.}}}{J_{\text{Mot.}}}$$

The operating frequencies listed for motors under load involve accelerations only, in contrast to the no-load operating frequencies. If the motors are decelerated with reverse current, these values must be divided by the K factor.

This K factor is:

K = 2.5 for constant load torque

K = 3.2 for quadratic rising load torque

The resulting relationship is:

$$S = \frac{S_{\text{Catalogue}} \text{ [S/h]}}{FI \times K}$$

[S/h] Operations per hour

Start ups per hour

Rated output P ₂ [kW]	2p = 2 Starts per hour FI = 1 Load torque		2p = 4 Starts per hour FI = 1 Load torque		2p = 6 Starts per hour FI = 1 Load torque		2p = 8 Starts per hour FI = 1 Load torque	
	const. [S/h]	squared [S/h]	const. [S/h]	squared [S/h]	const. [S/h]	squared [S/h]	const. [S/h]	squared [S/h]
0,12			11000	12000			6000	10200
0,18	8000	11000	11000	12000			6000	10200
0,25	8000	11000	11000	12000	10800	11450	6000	10200
0,37	8000	11000	11000	12000	10800	11450	5000	8500
0,55	8000	11000	10800	11550	10800	11450	5000	8500
0,75	7850	10500	10800	11550	6300	10590	4000	6800
1,1	5700	7560	6200	9550	5900	8880	6100	9900
1,5	3260	4410	3420	6480	2950	4580	9200	10500
2,2	1410	1960	2960	4400	2800	4100	4500	6930
3	980	1260	1930	2690	2600	3780	3900	5500
4	820	1200	2600	3490	2400	3460	2750	4530
5,5	610	880	1520	2050	2300	3150	2420	3480
7,5	780	1040	1000	1360	1340	1800	2190	3180
11	300	400	990	1360	720	1000	1100	1640
15	240	320	510	750	630	860	1330	1850
18,5	180	240	460	620	540	820	770	1040
22	130	170	130	180	400	540	1080	1430
30	65	100	300	400	290	380	410	560
37	55	75	230	310	170	240	370	560
45	50	65	110	170	200	280	205	305
55	40	55	95	130	220	310	270	305
75	30	45	70	100	100	170	220	330
90	25	35	40	65	90	150	120	180
110	18	27	23	30	80	125	170	230
132	16	25	30	55	70	100	150	190
160	12	22	30	45	55	85	150	190
200	8	20	22	35	50	75	150	190
250	8	18	18	30	40	60		
315	8	18	18	30				

Note

Frame size 355 to 450 on request

Switching operation can be implemented only with winding temperature monitoring using PTC thermistor temperature sensors.

Design series CD...Y

Considerations with regard to safety, service lifetime duration and environmental-friendliness, which are rooted in the philosophy of the company, have led to the development of energy-saving motors which generate approx. 40% less losses than motors widely used up to now.

These energy-saving motors conform with the following efficiency requirements:

1. Voluntary Agreement of CEMEP for Europe
2. According to EPACT in the USA and neighboring countries
3. The Standard and High Efficiency Stipulation for Australia and New Zealand
4. Other countries
5. Among other things, the motors are planned for the European Motor - Challenge Program

The special feature is that, for the first time, explosion-protected, flameproof enclosed three-phase asynchronous motors fulfill these requirements (although these special motor designs are exempted from the national requirements in the countries.)

With its high-efficiency range, ATB Motortechnik makes available to its customers high-quality, energy-saving motors in the power range from 0.75 kW to 700 kW in 2, 4, 6 and 8-pole implementation.

As well as high levels of efficiency, the high-efficiency motors offer the following benefits:

1. ATB motor technology offers a complete spectrum of energy-saving motors product
2. The efficiency classification permits a simple motor selection
3. The energy costs, which constitute approx. 97% of the motor costs in operation, are reduced and, in the case of approx. 4000h operating hours/year, result in the redemption of the extra expenditures involved in the purchase after only one year.
4. The lowering of the losses in the motor leads to the reduction in temperature of the winding, bearings and the roller bearing grease
5. Less losses also mean less noise
6. The energy-saving potential comes into its own optimally in frequency inverter operation and high working hours per year
7. The motors also benefit from the previous outstanding properties of specially selected high-quality materials, such as e.g. gray cast iron and high-quality electrical insulation materials.
8. The motors are suitable for frequency-inverter operation without any restrictions
9. The higher quality results in a longer motor service life

With this series, ATB Motortechnik GmbH makes an outstanding contribution to the preservation of our environment and to customer satisfaction, through the husbanding of environmental resources and lowering of operating costs.

Our energy-saving motors achieve the following demanding levels of efficiency:

CEMEP efficiency values

Motor power kW	Nominal efficiency with full load for 2 and 4-pole motors Range of power from 1.1 kW to 90kW	
	2-pole	4-pole
1,1	82,8	83,8
1,5	84,1	85,0
2,2	85,6	86,4
3,0	86,7	87,4
4,0	87,6	88,3
5,5	88,6	89,2
7,5	89,5	90,1
11,0	90,5	91,0
15,0	91,3	91,8
18,5	91,8	92,2
22,0	92,2	92,6
30,0	92,9	93,2
37,0	93,3	93,6
45,0	93,7	93,9
55,0	94,0	94,2
75,0	94,6	94,7
90,0	95,0	95,0

EPACT high efficiency values

Motor power kW/HP	Nominal efficiency with full load for 2 and 4-pole motors	
	2-pole	4-pole
0,75/1	75,5	82,5
1,1/1,5	82,5	84,0
1,5/2	84,0	84,0
2,2/3	85,5	87,5
3,7/5	87,5	87,5
5,5/7,5	88,5	89,5
11/15	90,2	91,0
15/20	90,2	91,0
18,5/25	91,0	92,4
22/30	91,0	93,0
30/40	91,7	93,0
37/50	92,4	93,0
45/60	93,0	93,6
55/75	93,0	94,1
75/100	93,6	94,5
90/125	94,5	94,5
110/150	94,5	95,0
150/175	95,0	95,0
175/200	95,0	95,0

Australian and New-Zealand Standard efficiency values

Motor power kW	Nominal efficiency with full load for 2-, 4-, 6- and 8-pole motors, Level 1 B according to AS/NZS 2006 1356,5			
	2-pole	4-pole	6-pole	8-pole
0,75	80,5	82,2	77,7	73,5
1,1	82,2	83,8	79,9	76,3
1,5	84,1	85,0	81,5	78,4
2,2	85,6	86,4	83,4	80,9
3,0	86,7	87,4	84,9	82,7
4,0	87,6	88,3	86,1	84,2
5,5	88,5	89,2	87,4	85,8
7,5	89,5	90,1	88,5	87,2
11,0	90,6	91,0	89,8	88,8
15,0	91,3	91,8	90,7	90,0
18,5	91,8	92,2	91,3	90,7
22,0	92,2	92,6	91,8	91,2
30,0	92,9	93,2	92,5	92,1
37,0	93,3	93,6	93,0	92,7
45,0	93,7	93,9	93,5	93,2
55,0	94,0	94,2	93,9	93,7
75,0	94,6	94,7	94,4	94,4
90,0	94,8	95,0	94,8	94,7
110	95,1	95,3	95,1	95,1
132	95,4	95,6	95,4	95,4
160	95,5	95,7	95,6	95,7
200	95,5	95,7	95,6	95,7
250	95,5	95,7	95,6	95,7
315	95,5	95,7	95,6	95,7
355	95,5	95,7	95,6	95,7
400	95,5	95,7	95,6	95,7
450	95,5	95,7	95,6	95,7
500	95,5	95,7	95,6	95,7
560	95,5	95,7	95,6	95,7
630	95,5	95,7	95,6	95,7

Frequency Inverter Operation

Frequencies above the rated frequency 50 Hz

If the frequency continues to increase beyond the drive's rated value, the speed increases accordingly.

The speeds corresponding to the maximum frequencies must not exceed the motor's speed limit. If a motor is operated above its rated frequency, its noise generation will increase.

To prevent excessive noise generation, the use of a motor with a separately driven external fan is recommended.

For operation above the rated frequency (50 Hz), there are two basic operating modes:

Three phase motors operated with a frequency inverter at constant flux up to 87Hz

If the motor is operated above its rated frequency at a voltage that increases in linear proportion with frequency, the magnetic flux remains constant. Because the iron losses increase out of proportion to the frequency, the maximum torque is lower than it is at 50 Hz (see illustrations of torque characteristic pages 56 and 57).

The technical data tables list the output at 87 Hz or at the maximum frequency for 2-pole motors. If voltage increase with frequency is linear, make sure that the voltage limits are not exceeded (see maximum permissible voltage load).

Three phase motors operated with a frequency inverter at constant voltage above 50 Hz

If the motor is operated above mains frequency at a constant voltage, the magnetic field is weakened.

The flux of the motor drops in inverse proportion to the frequency. In the range above the rated frequency (50 Hz to 87 Hz), the motor's output remains approximately constant i.e. the torque drops in inverse proportion to the frequency (see torque characteristic pages 56 and 57).

The maximum frequency for two-pole motors is listed in the technical data tables.

Power and torque values

The output values for inverter operation listed in the tables apply to continuous S1 operation at an ambient temperature of up to 40°C and an altitude of up to 1000 meters. (Values for higher room temperatures and altitudes available on request.)

The output figures apply for an inverter with

- a direct-current intermediate circuit (I-type inverter)
- a direct-voltage intermediate circuit with block or pulsed voltage (U-type inverter)

The thermal utilization of the motors corresponds to thermal class F.

Noise generation of three-phase motors in frequency inverter operation

Due to the harmonic oscillations, noise levels are higher in frequency inverter operation than they are at mains frequency. Without the use of a sinusoidal phase filter, the increase on the U-type inverter is about 7–15 dB(A); on the I-type inverter, it is about 3 dB(A).

If a filter is used with the U-type inverter, the noise levels at frequencies ≤ 50 Hz do not exceed the values at mains operation.

The noise increase from self-ventilated motors at frequencies > 50 Hz can be taken from the following table.

F [Hz]	ΔLP [dB(A)]
50	0
60	≤ 5
70	≤ 9
80	≤ 12
87	≤ 15

Guideline values for the increase of the sound pressure level through increase of the fan noise.

For low-noise drives with inverters, we offer special motors as listed on page 31.

Motors with separately driven external fans

Motors with separately driven external fans are recommended for drives with larger control ranges and constant load torque, as well as for operation above 50 Hz, to avoid an noise increase.

The fan motor corresponds to the explosion protection rating "flameproof enclosure".

The motor's electrical control system must ensure that the main motor can only operate while the external fan is running.

Installation note

If the current-limited inverter power output is not isolated from the mains, one of the following measures must be implemented to protect the ground conductor from overload as specified in DIN EN 501 78, VDE 0160 (equipment of heavy-current installations with electrical apparatus).

The dimensioning of the protective device in the main poles must take into account that, in the event of a fault, the PE conductor current can be greater than the main pole current. The protective conductor must therefore be correspondingly dimensioned for the fault current.

All the specifications of the inverter manufacturer with regard to this fault must be observed.

Permissible voltage demand

With frequency-inverter operation of the motors, voltage peaks are created by the switching operations, which additionally load the terminals and winding insulation. This is the case to an extreme degree if, in the case of pulse-controlled AC inverters with very steep flanks, vibrations are created on the line which can also overlay in unsuitable cases.

To avoid damaged bearings, an insulated bearing is therefore always installed on the non-drive end for inverter operation with motors from frame size 315.

The following values of the permissible voltage loading capacity through voltage peaks (limit values of the terminals and winding insulation) are securely dealt with.

1. **Connecting terminals** are designed in their air and creep sections for an effective rated voltage of 750 V on the basis of DIN EN 50019 - explosion protection of the explosion protection rating increased security "e". The permissible transient over voltage surge in frequency inverter operation of the motors is 2.15 kV phase-to-phase and phase-to-ground.
2. **Standard windings** for effective rated voltages 230/400 V and 500 V have a peak-voltage resistance of 1.6 kV phase-to-phase and phase-to-ground at continuous heating, corresponding to the heat class F. These motors are frequency-inverter-capable without additional filter.
3. **Standard windings** for effective rated voltage 400/690 V have a peak-voltage resistance of 1.6 kV phase-to-phase and phase-to-ground at continuous heating, corresponding to the heat class F. These motors are frequency-inverter-capable with additional filter.
4. **Special windings** for an effective rated voltage of 690 V have a peak-voltage resistance of 2.15 kV phase-to-phase and phase-to-ground at continuous heating, corresponding to the heat class F. These motors are frequency-inverter-capable without additional filters. They are identified with "U" at the end of the type construction designation of the motor.

Frequency Inverter Operation

Torque characteristic on the frequency inverter

$2p = 2$

Temperature class T4

56

Diagram 1: Frame size 63–160

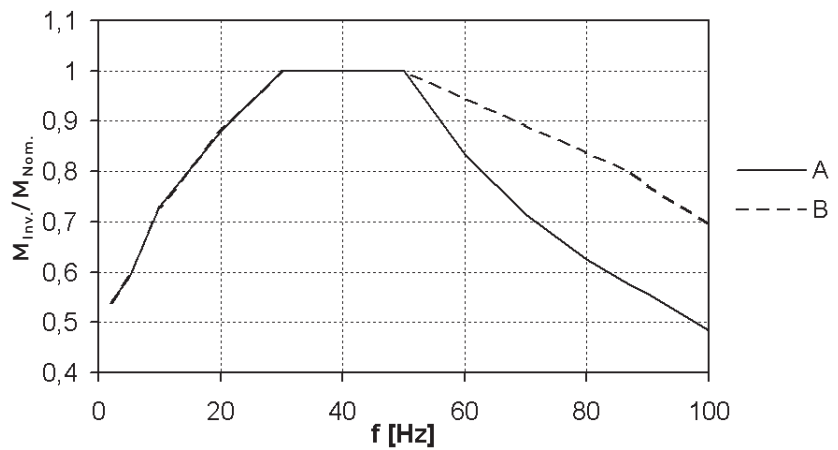

Diagram 2: Frame size 180–225

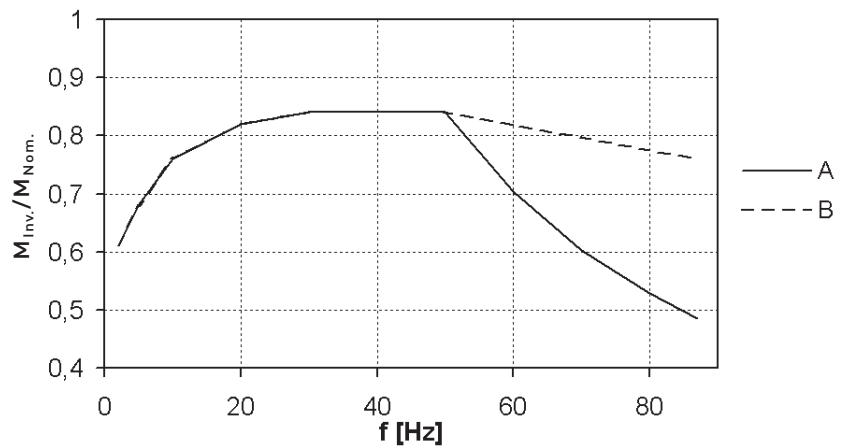
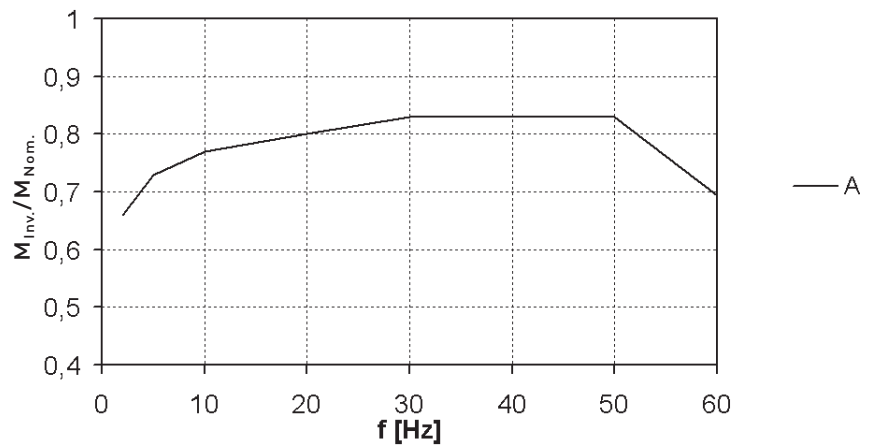

Diagram 3: Frame size 250–400



Curve A: Field weakening range above 50 Hz
 Curve B: Field weakening range above 87 Hz

Torque characteristic on the frequency inverter
 $2p = 4, 6, 8$
 Temperature class T4

Diagram 4: Frame size 63-160

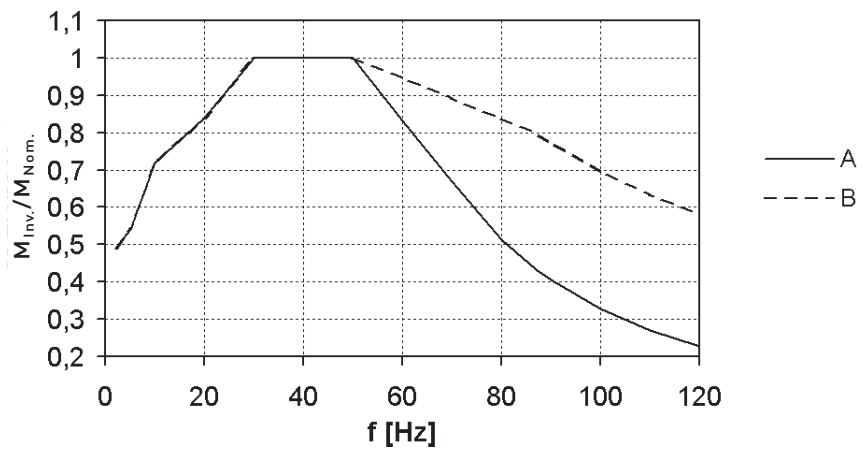

Diagram 5: Frame size 180-200

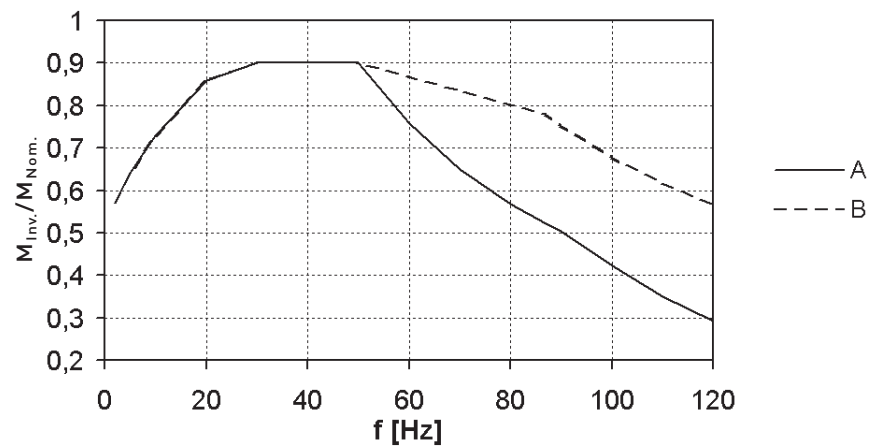
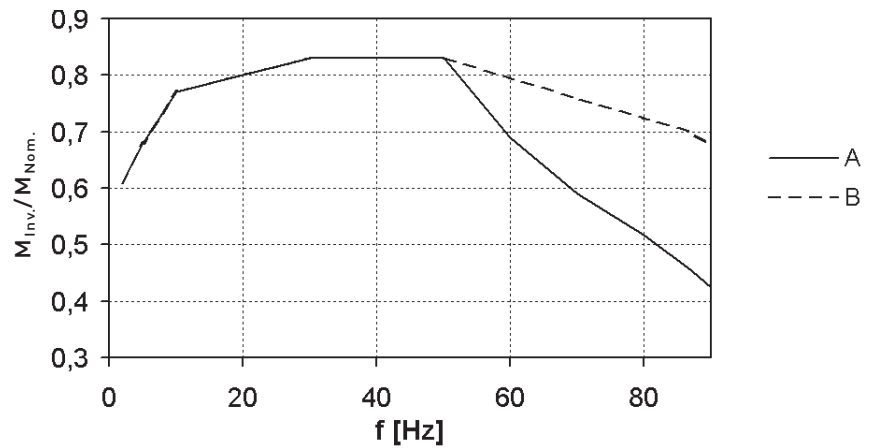

Diagram 6: Frame size 225-450



Curve A: Field weakening range above 50 Hz
 Curve B: Field weakening range above 87 Hz

Frequency Inverter Operation

Torque characteristic on the frequency inverter

$2p = 2$

Temperature class T4

56A

Diagram 1: Frame size 63–160

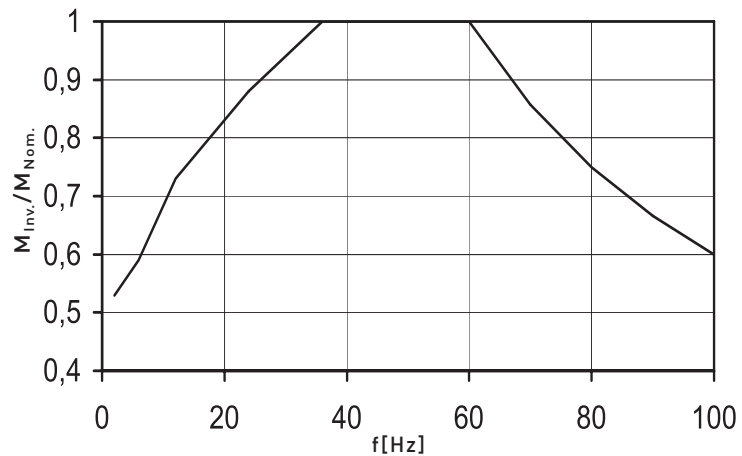

Diagram 2: Frame size 180–225

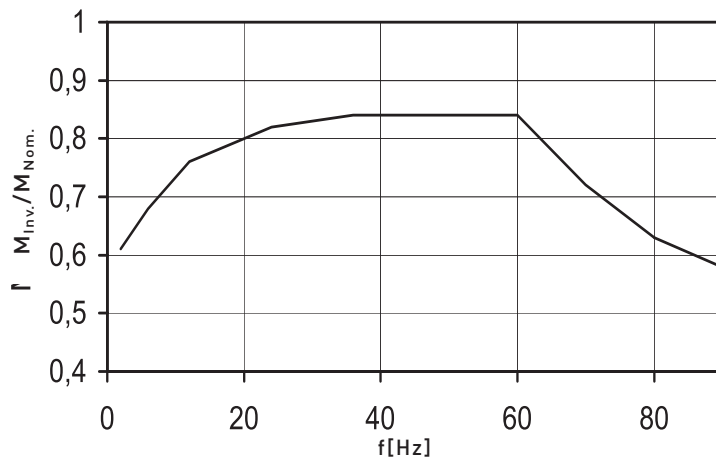
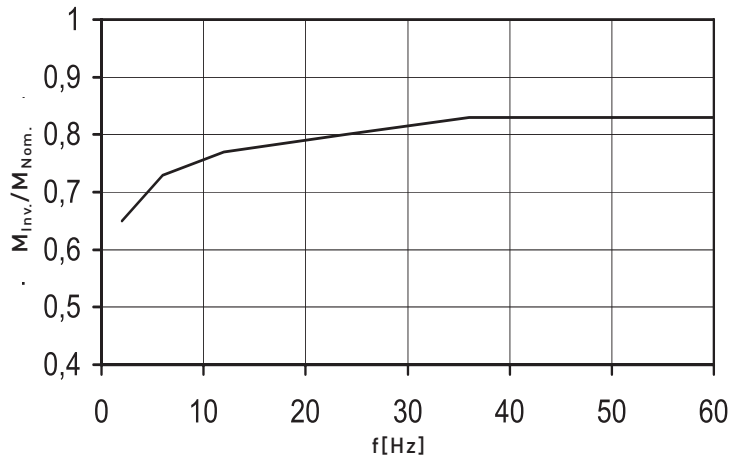

Diagram 3: Frame size 250–400



Curve: Field weakening range above 60 Hz

Torque characteristic on the frequency inverter
 $2p = 4, 6, 8$
 Temperature class T4

Diagram 4: Frame size 63–160

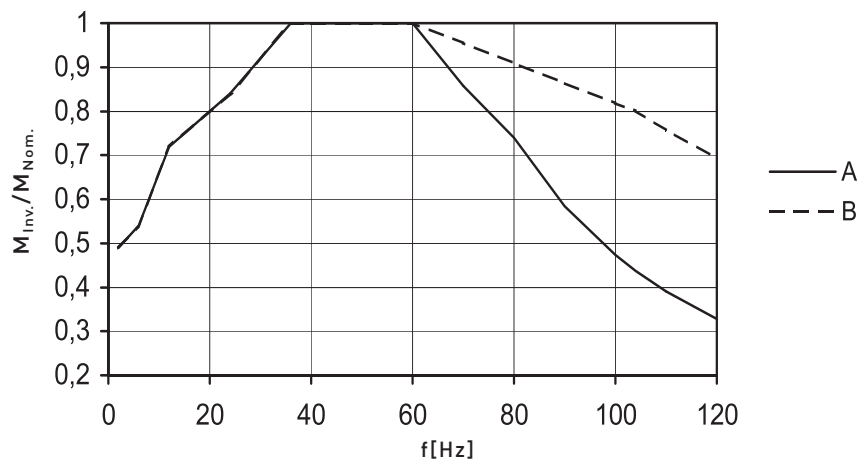

Diagram 5: Frame size 180–200

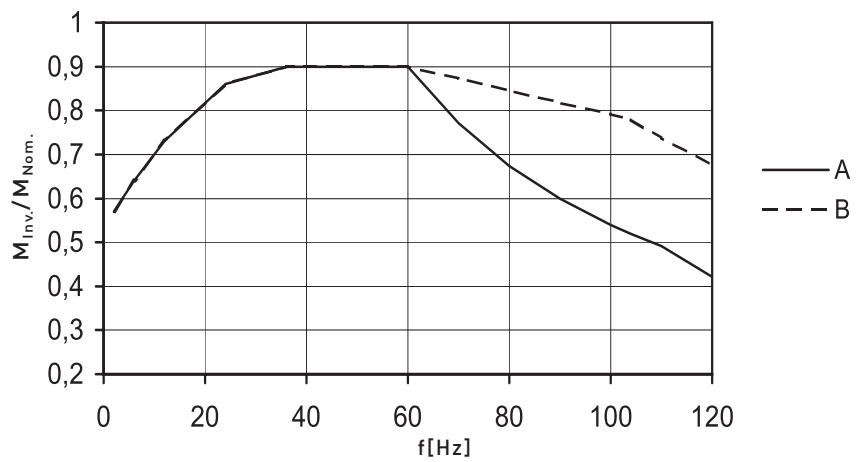
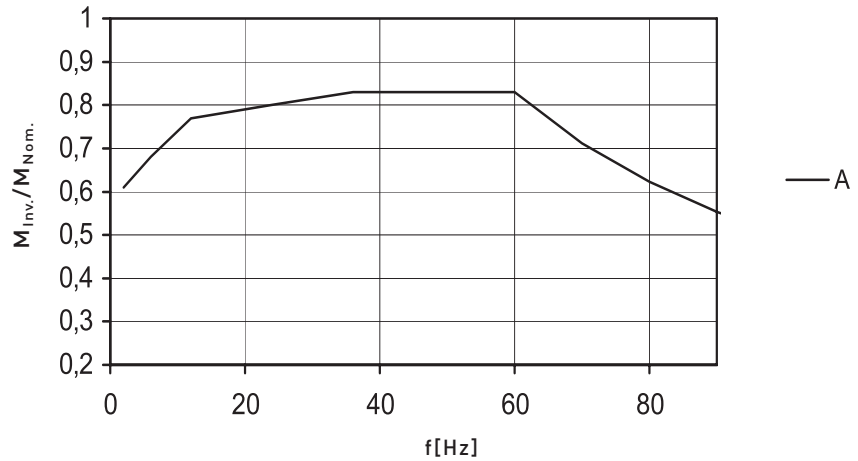

Diagram 6: Frame size 225–450



Curve A: Field weakening range above 60 Hz
 Curve B: Field weakening range above 104 Hz

Mains Operation 50 Hz

58

Temperature class T4, ns = 3000 rpm, 2p = 2

Type	Output P ₂ [kW]	Rated current at		Speed n [rpm]	Efficiency η [%]	Power factor cos φ	Torque M [Nm]	Starting torque M _A /M _N	Starting current I _A /I _N	Stalling torque M _k /M _N	Mass inertia J [kgm ²]	Weight ²⁾ m [kg]	Noise values with radial-flow fan		Noise values with axial-flow fan Typ ... A	
		400 V I [A]	500 V I [A]										L _P [dB(A)]	L _W [dB(A)]	L _P [dB(A)]	L _W [dB(A)]
63K-2	0,18	0,59	0,47	2905	66	0,67	0,59	4,6	6,8	6,5	0,00028	16	49	61		
63L-2	0,25	0,69	0,55	2860	70	0,75	0,83	3,4	5,8	4,7	0,00028	16	49	61		
71K-2	0,37	0,89	0,71	2800	71,5	0,84	1,26	2,7	5,2	3,5	0,00028	16	51	63		
71L-2	0,55	1,31	1,05	2810	72	0,84	1,87	2,8	5,5	3,6	0,00039	17	51	63		
80K-2	0,75	1,74	1,39	2790	74	0,84	2,57	2,7	4,8	3,3	0,00058	24	55	67		
80L-2	1,1	2,4	1,92	2820	78	0,85	3,73	2,8	5,5	3,5	0,0008	25	55	67		
90L ₁ -2	1,5	3,15	2,55	2840	78,5	0,87	5	2,7	5,5	3,2	0,0013	31	60	72		
90L ₂ -2	2,2	4,4	3,5	2850	83	0,87	7,4	2,7	5,6	3,3	0,0018	35	60	72		
100L-2	3	5,9	4,7	2850	85	0,87	10,1	2,7	6,8	3,3	0,0029	45	63	75		
112M-2	4	7,7	6,1	2880	85,5	0,88	13,3	2,3	6,5	3,1	0,0051	53	63	75	55	67
132S ₁ -2	5,5	10,4	8,3	2880	87	0,88	18,2	2,5	6,4	3,3	0,0089	95	63	76	55	68
132S ₂ -2	7,5	13,8	11,1	2910	88	0,89	24,6	2,7	6,8	3,5	0,0125	100	63	76	55	68
160M ₁ -2	11	20	16	2925	89	0,89	36	2,8	6,6	3,2	0,032	163	66	79	56	69
160M ₂ -2	15	26,5	21	2920	89,5	0,92	49	2,8	6,8	3,2	0,043	173	66	79	56	69
160L-2	18,5	32	25,5	2925	90,5	0,92	60	2,6	6,8	3,1	0,052	188	66	79	56	69
180M-2	22	37,5	30	2925	91,5	0,92	72	2,5	6,9	3	0,075	196	69	82	58	71
200L ₁ -2	30	52	41,5	2955	92,5	0,90	97	2,6	7,2	2,9	0,13	254	71	85	60	74
200L ₂ -2	37	63	50	2955	93,3	0,91	120	2,7	7,2	3	0,16	278	71	85	60	74
225M-2	45	77	62	2960	93,4	0,90	145	2,5	7,1	3	0,24	400	72	86	60	74
250M-2	55	94	75	2970	93,8	0,90	177	2,4	7,1	2,8	0,4	545	75	89	64	78
280S-2	75	127	102	2970	94,5	0,90	241	2,2	6,8	2,7	0,65	700	76	90	66	80
280M-2	90	151	121	2970	94,5	0,91	289	2,4	6,6	2,8	0,78	762	76	90	66	80
315S-2	110	184	147	2975	95	0,91	353	2	6,3	2,4	1,4	960	76	91	66	81
315M-2	132	220	175	2975	95,5	0,91	424	2,1	6,8	2,5	1,6	1025	76	91	66	81
315L ₁ -2	160	265	210	2975	95,7	0,91	514	2,4	6,9	2,7	1,7	1065	76	91	66	81
315L ₂ -2	200	330	260	2980	95,8	0,92	614	2,3	6,9	2,6	2,2	1270	76	91	66	81
315L ₃ -2	250	410 ¹⁾	330	2980	96	0,92	801	1,7	7,2	2,7	2,8	1420	76	91	66	81
355L ₁ -2	315	510 ¹⁾	410 ¹⁾	2980	96,6	0,92	1009	1,5	6,7	2,8	4,5	1900	81	97	68	84
355L ₂ -2	355	415 ¹⁾	415 ¹⁾	2985	96,8	0,93	1136	1,4	6,9	2,7	5	2050	81	97	68	84
355L ₃ -2	400	640 ¹⁾	515 ¹⁾	2985	96,8	0,93	1280	1,3	7	2,7	5,5	2350	81	97	68	84
400L-2	450	710 ¹⁾	570 ¹⁾	2990	97	0,94	1437	1,1	7,2	2,8	8,5	3030	81	97		

Note

- 1) Two parallel feeds are necessary in each case
- 2) Version B3 with terminal box

The figures are also valid for series BD...

Inverter Operation 50 Hz

Temperature class T4, ns = 3000 rpm, 2p = 2

40 °C ambient temperature, winding temperature rise F

Operation on the Ventilation	Mains	Inverter										Inverter forced ventilation	
		Self-cooling		Constant		Constant		Constant		Constant		Constant	
Torque character	-	drop by square val.		Constant		Constant		Constant		Constant		Constant	
Frequency	50 Hz	5-50 Hz		20-50 Hz		10-50 Hz		5-50 Hz		50-87 Hz ¹⁾		5-87 Hz ¹⁾	
Control range	-	1:10		1:2,5		1:5		1:10					
Speed range	-	300-3000 rpm		1200-3000 rpm		600-3000 rpm		300-3000 rpm		3000-5220 rpm		300-5220 rpm	
Output/torque	P ₂ [kW]	P _U [kW] 50 Hz	M _U [Nm]	P _U [kW] 50 Hz	M _U [Nm]	P _U [kW] 50 Hz	M _U [Nm]	P _U [kW] 50 Hz	M _U [Nm]	P _U [kW] 87 Hz	M _U [Nm]	P _U [kW] 50 Hz	P _U [kW] 87 Hz
63K-2	0,18	0,18	0,59	0,16	0,52	0,14	0,46	0,12	0,39	0,25	0,47	-	-
63L-2	0,25	0,25	0,83	0,22	0,73	0,19	0,63	0,15	0,49	0,37	0,7	-	-
71K-2	0,37	0,37	1,25	0,35	1,2	0,3	1	0,22	0,74	0,55	1	-	-
71L-2	0,55	0,55	1,9	0,52	1,8	0,45	1,5	0,33	1,1	0,8	1,5	-	-
80K-2	0,75	0,75	2,6	0,7	2,4	0,6	2	0,5	1,7	1,1	2	-	-
80L-2	1,1	1,1	3,7	1	3,4	0,9	3	0,75	2,5	1,6	2,9	-	-
90L ₁ -2	1,5	1,5	5	1,4	4,7	1,2	4	1	3,3	2,2	4	-	-
90L ₂ -2	2,2	2,2	7,4	2	6,7	1,7	5,7	1,4	4,7	3,3	6	-	-
100L-2	3	3	10	2,7	8,9	2,2	7,2	1,8	5,9	4,5	8,2	-	-
112M-2	4	4	13	3,7	12	3,2	11	2,5	8,2	6	11	-	-
132S ₁ -2	5,5	5,5	18	5	16	4,5	15	3,7	12	8	15	5,5	8
132S ₂ -2	7,5	7,5	25	7	23	6	20	5	16	11	20	7,5	10,5
160M ₁ -2	11	11	36	10	32	9	29	7,5	24	16	29	11	15
160M ₂ -2	15	14,5 ²⁾	47	13	42	12	39	10	32	21	38	14,5	20
160L-2	18,5	17,5 ²⁾	57	16	52	15	49	12,5	41	26	48	17,5	25
180M-2	22	21 ²⁾	68	20	65	18	58	15	49	30	55	21	29
200L ₁ -2	30	28 ²⁾	90	27	87	24	77	22	71	40	73	28	38
200L ₂ -2	37	32 ²⁾	103	31	100	28	90	27	87	49	90	32	45
225M-2	45	38 ²⁾	123	37	119	34	110	32	103	60	110	38	55
Frequency										50-60 Hz ¹⁾		5-60 Hz ¹⁾	
Speed range										3000-3600 rpm		300-3600 rpm	
250M-2	55	47 ²⁾	151	45	145	43	138	41	132	47	126	47	47
280S-2	75	62 ²⁾	199	60	193	58	186	55	177	62	166	62	62
280M-2	90	75 ²⁾	241	73	234	70	225	67	215	75	201	75	75
315S-2	110	95 ²⁾	304	90	288	88	282	85	272	95	258	95	95
315M-2	132	115	369	110	353	105	336	100	320	115	307	115	115
315L ₁ -2	160	140	449	135	433	128	410	120	385	140	374	140	140
315L ₂ -2	200	175	560	165	528	160	512	150	480	175	467	175	175
315L ₃ -2	250	215	688	205	656	200	640	185	592	215	574	215	215
355L ₁ -2	315	270	865	260	832	250	800	235	752	270	720	270	270
355L ₂ -2	355	305	976	295	944	285	912	265	848	305	813	305	305
355L ₃ -2	400	345	1104	335	1072	320	1024	300	960	345	918	345	345
400L-2	450	390	1245	375	1197	360	1149	340	1085	390	1038	390	390

Note

- 1) Higher frequencies on request
- 2) With inverter operation with output filter and practically sinusoidal output voltage, output as P₂

Output with operation at the inverter (guideline values), torque characteristic see page 56.
Overload protection through temperature sensors



Mains Operation 50 Hz

60

Temperature class T4, ns = 1500 rpm, 2p = 4

Type	Output P ₂ [kW]	Rated current at		Speed n [rpm]	Efficiency η [%]	Power factor cos φ	Torque M [Nm]	Starting torque M _A /M _N	Starting current I _A /I _N	Stalling torque M _K /M _N	Mass inertia J [kgm ²]	Weight ²⁾ m [kg]	Noise values with radial-flow fan		Noise values with axial-flow fan Typ ... A	
		400 V I [A]	500 V I [A]										L _P [dB(A)]	L _W [dB(A)]	L _P [dB(A)]	L _W [dB(A)]
63K-4	0,12	0,43	0,34	1445	67	0,60	0,79	3,9	5,6	3,9	0,00046	16	44	56		
63L-4	0,18	0,53	0,42	1415	70	0,70	1,2	2,7	4,7	2,7	0,00046	16	44	56		
71K-4	0,25	0,66	0,53	1370	68,5	0,80	1,74	2	3,9	2,5	0,00046	16	45	57		
71L-4	0,37	0,94	0,75	1380	71	0,80	2,56	2,2	3,9	2,6	0,00063	17	45	57		
80K-4	0,55	1,36	1,09	1380	73	0,80	3,8	2	3,8	2,3	0,00092	24	46	58		
80L-4	0,75	1,81	1,45	1400	75,5	0,79	5,1	2,1	4,5	2,5	0,0013	25	46	58		
90L ₁ -4	1,1	2,5	1,99	1400	77	0,83	7,5	2,1	4,8	2,5	0,0021	31	49	61		
90L ₂ -4	1,5	3,35	2,65	1405	79	0,82	10,2	2,3	5	2,7	0,0029	35	49	61		
100L ₁ -4	2,2	4,8	3,8	1420	81	0,82	14,8	2,4	5,4	2,8	0,0046	44	52	64		
100L ₂ -4	3	6,3	5,1	1415	82,5	0,83	20,2	2,3	5,5	2,7	0,0056	46	52	64		
112M-4	4	8,1	6,5	1435	85	0,84	26,6	2,7	6,8	3,2	0,011	59	54	66		
132S-4	5,5	10,7	8,6	1440	87	0,85	36,5	2,5	6,2	2,7	0,022	100	57	70	55	68
132M-4	7,5	14,3	11,4	1440	88,2	0,86	50	2,7	6,5	2,8	0,03	110	57	70	55	68
160M-4	11	21	16,7	1460	89,5	0,85	72	2,5	6,6	2,8	0,057	168	62	75	59	72
160L-4	15	28	22,5	1455	90	0,86	98	2,8	6,5	3,1	0,079	184	62	75	59	72
180M-4	18,5	34,5	27,5	1460	91	0,85	121	2,9	6,6	3	0,13	198	60	73	57	70
180L-4	22	41	32,5	1460	91,5	0,86	144	3	6,9	3	0,155	217	60	75	57	70
200L-4	30	53	42,5	1460	92,5	0,88	196	2,6	6,8	2,9	0,25	274	61	75	58	72
225S-4	37	65	52	1465	93	0,88	241	2,7	6,7	2,6	0,4	372	63	77	59	73
225M-4	45	79	63	1470	93,5	0,88	292	2,7	6,5	2,6	0,48	402	63	77	59	73
250M-4	55	95	76	1470	93,9	0,89	357	2,9	7,1	2,9	0,75	573	65	79	64	78
280S-4	75	133	107	1480	94,3	0,86	484	2,6	6,8	2,5	1,25	740	68	82	66	80
280M-4	90	160	128	1480	94,7	0,86	581	2,8	6,9	2,6	1,48	820	68	82	66	80
315S-4	110	194	155	1485	95,2	0,86	707	2,5	6,7	2,6	2,2	1040	69	84	66	81
315M-4	132	230	186	1485	95,5	0,86	849	2,5	6,8	2,7	2,7	1120	69	84	66	81
315L ₁ -4	160	280	225	1485	95,7	0,86	1029	2,6	6,9	2,6	3,1	1210	69	84	66	81
315L ₂ -4	200	345	275	1485	95,9	0,87	1286	2,6	6,9	2,6	3,9	1430	69	84	66	81
315L ₃ -4	250	430 ¹⁾	345	1490	96,2	0,87	1602	1,7	7,3	2,7	4,6	1565	69	84	66	81
355L ₁ -4	315	530 ¹⁾	425 ¹⁾	1490	96,3	0,89	2019	1,5	6,9	2,7	6,1	2050	72	88	68	84
355L ₂ -4	355	590 ¹⁾	470 ¹⁾	1490	96,6	0,90	2275	1,6	6,9	2,8	6,7	2200	72	88	68	84
355L ₃ -4	400	665 ¹⁾	530 ¹⁾	1490	97	0,90	2564	1,5	7	2,8	7,4	2430	72	88	68	84
400M-4	450	735 ¹⁾	590 ¹⁾	1495	97	0,91	2875	1,1	7,3	2,7	18	2850	78	94		
400L-4	500	815 ¹⁾	655 ¹⁾	1495	97,1	0,91	3194	1,1	7,3	2,7	20	3230	78	95		
450M-4	560	915 ¹⁾	730 ¹⁾	1495	97,2	0,91	3577	1	6,8	2,7	26	3500	79	95		
450L-4	630	1025 ¹⁾	820 ¹⁾	1495	97,4	0,91	4024	1	6,8	2,7	31	3800	79	95		
500 ...		on request														

Hinweise

- 1) Two parallel feeds are necessary in each case
- 2) Version B3 with terminal box

The figures are also valid for series BD...

Inverter Operation 50 Hz

Temperature class T4, ns = 1500 rpm, 2p = 4

40 °C ambient temperature, winding temperature rise F

Operation on the Ventilation	Mains	Inverter										Inverter forced ventilation	
		Self-cooling		Constant		Constant		Constant		Constant		Constant	
Torque character	-	drop by square val.		Constant		Constant		Constant		Constant		Constant	
Frequency	50 Hz	5-50 Hz		20-50 Hz		10-50 Hz		5-50 Hz		50-87 Hz ¹⁾		5-87 Hz ¹⁾	
Control range	-	1:10		1:2,5		1:5		1:10					
Speed range	-	150-1500 rpm		600-1500 rpm		300-1500 rpm		150-1500 rpm		1500-2610 rpm		150-2610 rpm	
Output/torque	P ₂ [kW]	P _U [kW] 50 Hz	M _U [Nm]	P _U [kW] 50 Hz	M _U [Nm]	P _U [kW] 50 Hz	M _U [Nm]	P _U [kW] 50 Hz	M _U [Nm]	P _U [kW] 87 Hz	M _U [Nm]	P _U [kW] 50 Hz	P _U [kW] 87 Hz
63K-4	0,12	0,12	0,79	0,11	0,73	0,09	0,59	0,08	0,53	0,18	0,68	-	-
63L-4	0,18	0,18	1,21	0,16	1,08	0,14	0,94	0,11	0,79	0,25	0,96	-	-
71K-4	0,25	0,25	1,7	0,22	1,5	0,19	1,25	0,15	1	0,37	1,4	-	-
71L-4	0,37	0,37	2,5	0,33	2,2	0,28	1,9	0,22	1,5	0,55	2	-	-
80K-4	0,55	0,55	3,8	0,52	3,5	0,45	3	0,33	2,2	0,8	2,9	-	-
80L-4	0,75	0,75	5,2	0,7	4,8	0,6	4	0,5	3,3	1,1	4	-	-
90L ₁ -4	1,1	1,1	7,5	1	6,7	0,9	6	0,75	5	1,6	5,9	-	-
90L ₂ -4	1,5	1,5	10	1,4	9,5	1,2	8	1	6,7	2,2	8	-	-
100L ₁ -4	2,2	2,2	15	2	13	1,7	11	1,4	9,3	3,3	12	-	-
100L ₂ -4	3 ¹⁾	3	20	2,8	19	2,2	15	1,8	12	4,5	16	-	-
112M-4	4	4	27	3,6	24	3	20	2,5	16	6	22	-	-
132S-4	5,5	5,5	37	5	33	4,4	29	3,7	24	8	29	5,5	8
132M-4	7,5	7,5	50	7	46	6	39	5	33	11	40	7,5	10,5
160M-4	11	11	72	10	65	9	58	7,5	49	16	59	11	15
160L-4	15	15	98	13,5	88	12	78	10	65	21	79	15	20
180M-4	18,5	18 ²⁾	118	17	111	15	97	12,5	81	26	95	18	25
180L-4	22	21 ²⁾	137	20	130	18	117	15	97	30	110	21	29
200L-4	30	28 ²⁾	183	27	176	24	156	21	136	40	146	28	37
225S-4	37	32 ²⁾	208	31	201	29	188	26	168	49	179	32	45
225M-4	45	38 ²⁾	247	37	240	35	227	32	207	60	220	38	55
250M-4	55	46 ²⁾	298	45	291	43	278	41	265	70	256	46	65
280S-4	75	62 ²⁾	400	60	386	58	373	55	354	95	348	62	88
280M-4	90	75 ²⁾	482	73	470	70	450	66	424	110	402	75	105
315S-4	110	95 ²⁾	610	90	577	88	564	83	532	140	512	95	130
315M-4	132	115	737	110	705	105	673	100	641	165	604	115	157
315L ₁ -4	160	140	897	135	865	128	820	120	769	200	732	140	190
315L ₂ -4	200	175	1122	165	1058	160	1026	150	961	250	915	175	240
315L ₃ -4	250	215	1378	205	1314	200	1282	185	1186	310	1134	215	305
355L ₁ -4	315	270	1731	260	1666	250	1602	235	1506	395	1445	270	385
355L ₂ -4	355	305	1955	295	1891	285	1827	265	1698	440	1610	305	425
355L ₃ -4	400	345	2209	335	2145	320	2048	300	1920	495	1820	345	480
400M-4	450	390	2500	375	2405	360	2307	340	2179	560	2050	390	540
400L-4	500	435	2778	415	2650	400	2553	380	2425	620	2274	435	600
450M-4	560	485	3097	465	2969	450	2873	425	2713	695	2549	485	670
450L-4	630	545	3480	525	3352	505	3224	475	3032	785	2879	545	755

Note

- 1) Higher frequencies on request
- 2) With inverter operation with output filter and practically sinusoidal output voltage, output as P₂

Output with operation at the inverter (guideline values), torque characteristic see page 57.
Overload protection through temperature sensors

Mains Operation 50 Hz

62

Temperature class T4, ns = 1000 rpm, 2p = 6

Type	Output P ₂ [kW]	Rated current at		Speed n [rpm]	Efficiency η [%]	Power factor cos φ	Torque M [Nm]	Starting torque M _s /M _N	Starting current I _s /I _N	Stalling torque M _K /M _N	Mass inertia J [kgm ²]	Weight ²⁾ m [kg]	Noise values with radial-flow fan	
		400 V I [A]	500 V I [A]										L _p [dB(A)]	L _w [dB(A)]
71L-6	0,25	0,82	0,66	920	62	0,71	2,6	2,2	3,5	2,6	0,0012	17	44	56
80K-6	0,37	1,12	0,90	925	67	0,71	3,8	2,5	4,1	2,8	0,0019	24	44	56
80L-6	0,55	1,6	1,28	925	69	0,72	5,7	2,4	4	2,7	0,0025	25	44	56
90L ₁ -6	0,75	2,15	1,72	910	67	0,75	7,9	1,8	3,4	2,1	0,0033	31	47	59
90L ₂ -6	1,1	3,05	2,45	920	71	0,73	11,4	2	3,7	2,2	0,0046	35	47	59
100L-6	1,5	3,75	3	945	77	0,75	15,2	2,4	5	2,9	0,0095	46	50	62
112M-6	2,2	5,2	4,2	950	81	0,75	22,1	2,7	5,6	3,1	0,017	59	53	65
132S-6	3	6,6	5,3	965	84	0,78	29,7	2,7	6,3	3,1	0,031	100	56	69
132M ₁ -6	4	8,6	6,9	960	85	0,79	40	2,6	6	3	0,037	104	56	69
132M ₂ -6	5,5	11,4	9,1	960	86	0,81	55	2,6	6,4	3	0,043	112	56	69
160M-6	7,5	14,7	11,7	960	86,8	0,85	75	2,5	6,8	3,3	0,087	170	58	71
160L-6	11	21	16,9	965	87,5	0,86	109	2,5	6,7	3,2	0,12	190	58	71
180L-6	15	28,5	23	965	90	0,84	148	2,4	6,9	3,2	0,19	215	58	71
200L ₁ -6	18,5	35	28	975	90,5	0,84	181	1,9	6,2	2,7	0,28	270	58	71
200L ₂ -6	22	41	33	970	91	0,85	217	2,2	6,8	3	0,31	280	58	72
225M-6	30	56	45	975	92	0,84	294	2,8	6,6	2,5	0,69	404	58	72
250M-6	37	69	55	980	92,5	0,84	361	2,8	6,6	2,6	1,03	570	58	76
280S-6	45	84	67	985	93,5	0,83	436	2,8	5,8	2,4	1,35	720	62	77
280M-6	55	104	83	985	93,5	0,82	533	2,7	5,8	2,3	1,7	770	63	79
315S-6	75	132	106	990	94	0,87	723	2,6	6,4	2,4	4,3	995	65	79
315M-6	90	157	125	990	94,2	0,88	868	2,6	6,5	2,4	5	1050	65	84
315L ₁ -6	110	191	153	990	94,5	0,88	1061	2,7	6,5	2,5	6	1145	69	84
315L ₂ -6	132	230	183	990	94,7	0,88	1273	2,7	6,7	2,5	7,3	1265	69	84
315L ₃ -6	160	275	220	990	95	0,88	1543	2,6	6,8	2,5	8,3	1440	69	84
355M-6	200	345	275	990	95,5	0,88	1929	1,8	6,7	2,7	11,3	1750	74	90
355L ₁ -6	250	430 ¹⁾	345	990	95,9	0,88	2411	1,8	6,7	2,7	13,8	1950	74	90
355L ₂ -6	315	540 ¹⁾	430 ¹⁾	990	96	0,88	3039	1,7	6,9	2,6	17,6	2300	74	90
400M-6	355	595 ¹⁾	475 ¹⁾	994	96,6	0,89	3411	1,1	6,6	2,7	27	2850	78	94
400L-6	400	670 ¹⁾	535 ¹⁾	994	96,6	0,89	3843	1,1	6,8	2,6	31	3230	78	94
450M-6	450	755 ¹⁾	605 ¹⁾	995	96,6	0,89	4319	1,2	6,8	2,8	46	3500	78	94
450L-6	500	835 ¹⁾	670 ¹⁾	995	97	0,89	4799	1,1	6,8	2,7	51	3800	78	94
500 ...	on request													

Note

- 1) Two parallel feeds are necessary in each case
- 2) Version B3 with terminal box

The figures are also valid for series BD...

Inverter Operation 50 Hz

Temperature class T4, ns = 1000 rpm, 2p = 6

40 °C ambient temperature, winding temperature rise F

Operation on the Ventilation	Mains	Inverter										Inverter forced ventilation	
		Self-cooling		Constant		Constant		Constant		Constant		Constant	
Torque character	-	drop by square val.		Constant		Constant		Constant		Constant		Constant	
Frequency	50 Hz	5-50 Hz		20-50 Hz		10-50 Hz		5-50 Hz		50-87 Hz ¹⁾		5-87 Hz ¹⁾	
Control range	-	1:10		1:2,5		1:5		1:10					
Speed range	-	100-1000 rpm		400-1000 rpm		200-1000 rpm		100-1000 rpm		1000-1740 rpm		100-1740 rpm	
Output/torque	P ₂ [kW]	P _U [kW] 50 Hz	M _U [Nm]	P _U [kW] 50 Hz	M _U [Nm]	P _U [kW] 50 Hz	M _U [Nm]	P _U [kW] 50 Hz	M _U [Nm]	P _U [kW] 87 Hz	M _U [Nm]	P _U [kW] 50 Hz	P _U [kW] 87 Hz
71L-6	0,25	0,25	2,6	0,22	2,2	0,18	1,8	0,16	1,6	0,37	2	-	-
80K-6	0,37	0,37	3,8	0,33	3,4	0,27	2,7	0,22	2,2	0,55	3	-	-
80L-6	0,55	0,55	5,7	0,5	5,1	0,4	4	0,33	3,3	0,8	4,4	-	-
90L ₁ -6	0,75	0,75	7,8	0,65	6,7	0,55	5,5	0,42	4,2	1,1	6	-	-
90L ₂ -6	1,1	1,1	11,4	0,9	9,2	0,8	8	0,6	6	1,6	8,8	-	-
100L-6	1,5	1,5	15	1,4	14	1,1	11	0,9	9	2,2	12	-	-
112M-6	2,2	2,2	22	2	20	1,7	17	1,3	13	3,3	18	-	-
132S-6	3	3	30	2,7	27	2,2	22	1,8	18	4,5	25	3	4,2
132M ₁ -6	4	4	40	3,5	35	3	30	2,5	25	6	33	4	5,5
132M ₂ -6	5,5	5,5	55	4,8	48	4	40	3,3	33	8	44	5,5	7,6
160M-6	7,5	7,5	74	7	69	6	59	5	49	11	60	7,5	10,5
160L-6	11	11	110	10	98	9	88	7,5	73	16	88	11	15
180L-6	15	15	149	13	128	12	118	10	98	21	115	15	20
200L ₁ -6	18,5	17,5 ²⁾	171	16	157	14	137	12	118	26	143	17,5	24
200L ₂ -6	22	20 ²⁾	196	19	186	17	167	15	147	30	165	20	28
225M-6	30	27 ²⁾	262	25	242	23	223	21	204	40	220	27	37
250M-6	37	33 ²⁾	320	31	301	29	281	26	252	49	269	33	45
280S-6	45	40 ²⁾	386	37	357	35	338	32	309	60	329	40	55
280M-6	55	47 ²⁾	453	45	434	43	415	41	396	70	384	47	65
315S-6	75	65 ²⁾	627	62	598	58	559	56	540	95	521	65	88
315M-6	90	78 ²⁾	752	73	704	70	675	68	656	110	604	78	105
315L ₁ -6	110	95 ²⁾	916	90	868	88	849	85	820	140	768	95	130
315L ₂ -6	132	115	1109	110	1061	105	1013	100	965	165	906	115	157
315L ₃ -6	160	140	1351	135	1302	128	1235	120	1158	200	1098	140	190
355M-6	200	170	1640	165	1592	160	1543	150	1447	250	1372	170	240
355L ₁ -6	250	215	2074	205	1978	200	1929	190	1833	310	1701	215	305
355L ₂ -6	315	270	2605	260	2508	250	2412	235	2267	395	2168	270	385
400M-6	355	305	2942	295	2846	285	2749	265	2556	440	2415	305	425
400L-6	400	345	3328	355	3232	320	3087	300	2894	495	2717	345	480
450M-6	450	390	3762	375	3617	360	3473	340	3280	560	3074	390	540
450L-6	500	435	4196	415	4003	400	3859	375	3618	620	3404	435	600

Note

- 1) Higher frequencies on request
- 2) With inverter operation with output filter and practically sinusoidal output voltage, output as P₂

Output with operation at the inverter (guideline values), torque characteristic see page 57.
Overload protection through temperature sensors



Mains Operation 50 Hz

64

Temperature class T4, ns = 750 rpm, 2p = 8

Type	Output P ₂ [kW]	Rated current at		Speed n [rpm]	Efficiency η [%]	Power factor cos φ	Torque M [Nm]	Starting torque M _s /M _N	Starting current I _s /I _N	Stalling torque M _K /M _N	Mass inertia J [kgm ²]	Weight ²⁾ m [kg]	Noise values with radial-flow fan		
		400 V I [A]	500 V I [A]										L _p [dB(A)]	L _w [dB(A)]	
71L-8	0,12	0,52	0,42	680	51	0,65	1,7	1,9	2,6	2,4	0,0012	17	41	53	
80K-8	0,18	0,66	0,52	690	61	0,65	2,5	2,2	3,2	2,6	0,0019	24	42	54	
80L-8	0,25	0,91	0,73	690	62	0,64	3,5	2,2	3,2	2,5	0,0025	25	42	54	
90L ₁ -8	0,37	1,3	1,04	690	63	0,65	5,1	1,8	3	2,2	0,0033	31	46	58	
90L ₂ -8	0,55	1,85	1,48	690	67	0,64	7,6	1,8	3,1	2,2	0,0046	35	46	58	
100L ₁ -8	0,75	2,3	1,85	710	71	0,66	10,1	2,4	4	2,6	0,008	44	49	61	
100L ₂ -8	1,1	3,15	2,5	695	69	0,73	15,1	2	3,8	2,4	0,0095	46	49	61	
112M-8	1,5	4,15	3,3	710	78	0,67	20,2	2,2	4,6	2,8	0,017	59	52	64	
132S-8	2,2	5	4	695	80	0,79	30	2	4,1	2,3	0,029	97	53	66	
132M-8	3	6,9	5,6	705	81	0,77	41	2,4	4,6	2,7	0,036	113	53	66	
160M ₁ -8	4	8,7	7	715	85	0,78	53	1,8	4,6	2,3	0,071	157	54	67	
160M ₂ -8	5,5	12	9,6	720	86	0,77	73	2,1	5,4	2,8	0,105	170	54	67	
160L-8	7,5	16,3	13	720	86,5	0,77	99	2,2	5,6	2,9	0,136	190	54	67	
180L-8	11	22,5	18,1	725	89	0,79	145	2,4	6,4	3	0,22	215	56	69	
200L-8	15	30	24	730	89,5	0,80	196	2,4	6,9	3,2	0,4	280	56	70	
225S-8	18,5	37,5	30	730	90	0,79	242	2,2	6,3	3	0,56	372	57	71	
225M-8	22	44	35,5	730	91	0,79	288	2,2	6,6	3	0,69	404	57	71	
250M-8	30	57	45,5	735	92,5	0,82	390	2	6,8	3	1,2	550	58	72	
280S-8	37	70	56	735	92,8	0,82	481	2,1	6,2	2,8	1,9	740	61	75	
280M-8	45	85	67	735	92,8	0,82	585	2	6,3	2,6	2,3	800	61	75	
315S-8	55	103	83	740	92,5	0,83	710	2,5	6	2,6	4,3	995	68	83	
315M-8	75	140	112	740	93	0,83	968	2,5	6,3	2,5	5	1050	68	83	
315L ₁ -8	90	168	134	740	93,2	0,83	1161	2,6	6,6	2,6	6	1145	68	83	
315L ₂ -8	110	210	166	740	93,2	0,82	1420	2,7	6,8	2,7	7,3	1265	68	83	
315L ₃ -8	132	250	199	735	93,4	0,82	1715	2,5	6,3	2,5	8,3	1440	68	83	
355M-8	160	295	235	740	95,1	0,83	2065	1,9	6,4	2,4	11,4	1750	70	86	
355L ₁ -8	200	370	295	745	95,5	0,82	2564	1,7	6,6	2,5	13,9	1950	70	86	
355L ₂ -8	250	460 ¹⁾	370	745	95,6	0,82	3205	1,7	6,7	2,5	17,7	2300	73	89	
400M-8	315	570 ¹⁾	455 ¹⁾	745	96,2	0,83	4038	1,2	6,2	2,4	30	3100	73	89	
400L-8	355	640 ¹⁾	515 ¹⁾	745	96,3	0,83	4551	1,1	6,3	2,3	34	3440	74	90	
450M-8	400	710 ¹⁾	570 ¹⁾	745	96,6	0,84	5128	1	6,1	2,2	51	3750	74	90	
450L-8	450	800 ¹⁾	640 ¹⁾	745	96,7	0,84	5768	1	6,1	2,2	57	4050	74	90	
500 ...	on request														

Note

1) Two parallel feeds are necessary in each case

2) Version B3 with terminal box

The figures are also valid for series BD...

Inverter Operation 50 Hz

Temperature class T4, ns = 750 rpm, 2p = 8

40 °C ambient temperature, winding temperature rise F

Operation on the Ventilation	Mains	Inverter										Inverter forced ventilation	
		Self-cooling		Constant		Constant		Constant		Constant		Constant	
Torque character	-	drop by square val.		Constant		Constant		Constant		Constant		Constant	
Frequency	50 Hz	5-50 Hz		20-50 Hz		10-50 Hz		5-50 Hz		50-87 Hz ¹⁾		5-87 Hz ¹⁾	
Control range	-	1:10		1:2,5		1:5		1:10					
Speed range	-	75-750 rpm		300-750 rpm		150-750 rpm		75-750 rpm		750-1305 rpm		75-1305 rpm	
Output/torque	P ₂ [kW]	P _U [kW] 50 Hz	M _U [Nm]	P _U [kW] 50 Hz	M _U [Nm]	P _U [kW] 50 Hz	M _U [Nm]	P _U [kW] 50 Hz	M _U [Nm]	P _U [kW] 87 Hz	M _U [Nm]	P _U [kW] 50 Hz	P _U [kW] 87 Hz
71L-8	0,12	0,12	1,7	0,11	1,5	0,1	1,4	0,08	1,1	0,18	1,3	-	-
80K-8	0,18	0,18	2,5	0,16	2,2	0,13	1,7	0,11	1,5	0,25	1,8	-	-
80L-8	0,25	0,25	3,4	0,22	3	0,18	2,4	0,16	2,2	0,37	2,7	-	-
90L ₁ -8	0,37	0,37	5,1	0,33	4,4	0,27	3,6	0,22	3	0,55	4	-	-
90L ₂ -8	0,55	0,55	7,5	0,5	6,7	0,4	5,4	0,33	4,4	0,8	5,9	-	-
100L ₁ -8	0,75	0,75	10,2	0,65	8,7	0,55	7,4	0,42	5,6	1,1	8	-	-
100L ₂ -8	1,1	1,1	15,1	0,9	12	0,8	11	0,6	8,1	1,6	12	-	-
112M-8	1,5	1,5	20,2	1,4	19	1,1	15	0,9	12	2,2	16	-	-
132S-8	2,2	2,2	30	2	27	1,7	23	1,3	17	3,3	24	2,2	3,1
132M-8	3	3	40,5	2,7	36	2,2	29	1,8	24	4,5	33	3	4,2
160M ₁ -8	4	4	53,5	3,5	46	3	40	2,5	33	6	44	4	5,5
160M ₂ -8	5,5	5,5	73	4,8	64	4	52	3,3	44	8	59	5,5	7,6
160L-8	7,5	7,5	100	7	92	5,5	72	4,5	59	11	80	7,5	10,5
180L-8	11	11	146	10	131	8	104	7	91	16	117	11	15
200L-8	15	15	195	13	170	11	143	10	130	21	154	15	20
225S-8	18,5	18,5	240	16	208	14	181	12	155	26	190	18,5	25
225M-8	22	22	286	19	245	17	219	15	194	30	220	22	29
250M-8	30	27 ²⁾	348	25	323	23	297	21	271	40	293	27	37
280S-8	37	33 ²⁾	426	31	400	29	374	26	336	49	359	33	45
280M-8	45	40 ²⁾	516	37	478	35	452	32	413	60	439	40	55
315S-8	55	48 ²⁾	619	45	581	43	555	41	529	70	512	48	65
315M-8	75	65 ²⁾	839	62	800	58	749	56	723	95	695	65	88
315L ₁ -8	90	78 ²⁾	1007	73	942	70	903	68	878	110	805	78	105
315L ₂ -8	110	95 ²⁾	1226	90	1161	88	1136	85	1097	140	1025	95	130
315L ₃ -8	132	115	1484	110	1420	105	1309	100	1247	165	1027	115	157
355M-8	160	140	1807	135	1743	128	1596	120	1496	200	1464	140	190
355L ₁ -8	200	170	2194	165	2129	160	1994	150	1870	250	1830	170	240
355L ₂ -8	250	215	2775	205	2646	200	2493	190	2368	310	2269	215	305
400M-8	315	270	3484	260	3355	250	3116	235	2929	395	2891	270	385
400L-8	355	305	3935	295	3807	285	3553	265	3303	440	3220	305	425
450M-8	400	345	4452	335	4323	320	3989	300	3740	495	3622	345	480
450L-8	450	390	5033	375	4839	360	4488	340	4239	560	4098	390	540

Note

- 1) Higher frequencies on request
- 2) With inverter operation with output filter and practically sinusoidal output voltage, output as P₂

Output with operation at the inverter (guideline values), torque characteristic see page 57.
Overload protection through temperature sensors



Partial Load Data 50 Hz

66

Efficiency [%]

Frame size CD...	2p = 2 P / P _N				2p = 4 P / P _N				2p = 6 P / P _N				2p = 8 P / P _N			
	0,25	0,5	0,75	1	0,25	0,5	0,75	1	0,25	0,5	0,75	1	0,25	0,5	0,75	1
63K	38	53	62	66	40	55	63	67	-	-	-	-	-	-	-	-
63L	46	61	67	70	50	63	68	70	-	-	-	-	-	-	-	-
71K	53	65	71	71,5	56	67	69	68,5	-	-	-	-	-	-	-	-
71L	54	67	72	73	60	70	72	71	38	53	60	62	27	41	48	51
80K	58	69	73	74	63	72	74	73	44	60	65	67	37	52,5	58,5	61
80L	63	74	78	78	64	75	76,5	75,5	49	64	68,5	69	38	53	59	62
90L ₁	64	75	78,5	79	65	75	77	77	54	65	68	67	39	54	61	63
90L ₂	70	80	82,5	83	67,5	77,5	79,5	79	54	67	70,5	71	46	61	66,5	67
100L ₁	-	-	-	-	69,5	76	80,5	81	-	-	-	-	47	62	68,5	71
100L/L ₂	71	80,5	84,5	85	68	79	82,7	82,5	61,5	73	76,8	77	53	65,5	69,8	69
112M	75	84,3	85,8	85,5	75	83	85,2	85	68	77,5	80,5	81	62	73,5	77	78
132S/S ₁	72	82,5	86,5	87	77	85,2	87,3	87	73	81,5	83,8	84	68,5	78,7	81	80
132S ₂	74	84	87,8	88	-	-	-	-	-	-	-	-	-	-	-	-
132M/M ₁	-	-	-	-	79,5	87	88,5	88,2	73,5	82,3	84,9	85	69	79	81,4	81
132M ₂	-	-	-	-	-	-	-	-	78,4	85,4	86,5	86	-	-	-	-
160M/M ₁	76	86	88,8	89	81,5	87,7	89,7	89,5	78	84,9	86,8	86,8	72,5	82	84,9	85
160M ₂	81	87,6	89,6	89,5	-	-	-	-	-	-	-	-	75	83,5	86	86
160L	83,5	89,5	90,7	90,5	83,7	89,3	90,3	90	81,5	87	88	87,5	77	84,8	86,5	86,5
180M	86,9	91,2	92	91,5	85,8	90,8	91,5	91	-	-	-	-	-	-	-	-
180L	-	-	-	-	88,2	91,3	91,8	91,5	83,5	89,7	90,4	90	82	88,3	89,5	89
200L/L ₁	86	91,2	92,5	92,5	88,4	92,6	92,9	92,5	87	90,5	91	90,5	85,5	89,5	90	89,5
200L ₂	86	92	93,2	93,3	-	-	-	-	85,5	90	91,3	91	-	-	-	-
225S	-	-	-	-	88,3	92,4	93,1	93	-	-	-	-	82,5	88,7	90	90
225M	87	92,4	93,2	93,4	88,9	92,8	93,7	93,5	87,5	91,8	92,4	92	84,3	89,8	91,2	91
250M	86,5	91,8	93,5	93,8	90,4	93,5	94	93,9	87,5	92	92,7	92,5	88	92	92,7	92,5
280S	88,5	93,1	94,2	94,5	90,3	93,8	94,5	94,3	88,4	92,8	93,6	93,5	88	92	92,9	92,8
280M	88,7	93,2	94,2	94,5	90,5	94	94,7	94,7	88,7	92,9	93,6	93,5	88,1	92,3	93	92,8
315S	92,7	95	95,4	95	91	94,3	95,2	95,2	91	93,8	94,5	94	88	92	92,9	92,5
315M	91	93,8	95,1	95,5	91,8	94,6	95,4	95,5	91	94	94,5	94,2	88,5	92,5	93,4	93
315L ₁	92,8	95	95,4	95,7	92	95	95,8	95,7	91,5	94,2	94,9	94,5	89	92,8	93,5	93,2
315L ₂	93	95	95,5	95,8	92,3	95,1	96	95,9	92	94,5	95,1	94,7	89,5	93	93,6	93,2
315L ₃	92	95,1	95,8	96	92,3	95,2	96,1	96,2	92,3	94,9	95,4	95	90	93,2	93,8	93,4
355M	-	-	-	-	-	-	-	-	93	95,5	96	95,6	91	94,5	95	95,1
355L/L ₁	93	96,5	96,8	96,6	93	96	96,5	96,3	93,2	95,7	96,1	95,9	91,5	94,8	95,4	95,5
355L ₂	93,3	95,7	96,8	96,8	93	96,2	96,6	96,6	93,3	95,8	96,1	96	91,5	94,8	95,5	95,6
355L ₃	93,43	95,7	96,9	96,8	93,6	96,5	97,1	97	-	-	-	-	-	-	-	-

The figures are also valid for series BD...

Frame size CD...	2p = 2 P/P _N				2p = 4 P/P _N				2p = 6 P/P _N				2p = 8 P/P _N			
	0,25	0,5	0,75	1	0,25	0,5	0,75	1	0,25	0,5	0,75	1	0,25	0,5	0,75	1
63K	0,38	0,50	0,60	0,67	0,31	0,42	0,52	0,60	-	-	-	-	-	-	-	-
63L	0,41	0,56	0,67	0,75	0,35	0,49	0,61	0,70	-	-	-	-	-	-	-	-
71K	0,49	0,65	0,78	0,84	0,42	0,62	0,73	0,80	-	-	-	-	-	-	-	-
71L	0,48	0,67	0,78	0,84	0,42	0,62	0,73	0,80	0,36	0,49	0,61	0,71	0,36	0,46	0,56	0,65
80K	0,53	0,70	0,80	0,84	0,43	0,62	0,74	0,80	0,33	0,48	0,61	0,71	0,34	0,46	0,56	0,65
80L	0,45	0,67	0,78	0,85	0,42	0,61	0,72	0,79	0,36	0,52	0,64	0,72	0,31	0,43	0,53	0,64
90L ₁	0,55	0,72	0,82	0,87	0,46	0,66	0,77	0,83	0,37	0,55	0,67	0,75	0,31	0,44	0,56	0,65
90L ₂	0,48	0,69	0,81	0,87	0,45	0,65	0,77	0,82	0,35	0,52	0,64	0,73	0,30	0,44	0,57	0,64
100L ₁	-	-	-	-	0,38	0,69	0,73	0,82	-	-	-	-	0,32	0,44	0,55	0,66
100L/L ₂	0,50	0,70	0,80	0,87	0,44	0,64	0,76	0,83	0,35	0,54	0,66	0,75	0,35	0,50	0,64	0,73
112M	0,59	0,78	0,85	0,88	0,44	0,65	0,77	0,84	0,36	0,54	0,66	0,75	0,30	0,47	0,56	0,67
132S/S ₁	0,60	0,77	0,84	0,88	0,5	0,70	0,80	0,85	0,37	0,57	0,69	0,78	0,41	0,60	0,72	0,79
132S ₂	0,56	0,75	0,84	0,89	-	-	-	-	-	-	-	-	-	-	-	-
132M/M ₁	-	-	-	-	0,51	0,72	0,81	0,86	0,38	0,57	0,72	0,79	0,39	0,58	0,70	0,77
132M ₂	-	-	-	-	-	-	-	-	0,41	0,62	0,75	0,81	-	-	-	-
160M/M ₁	0,62	0,8	0,86	0,89	0,52	0,72	0,81	0,85	0,49	0,70	0,80	0,85	0,41	0,61	0,72	0,78
160M ₂	0,71	0,87	0,91	0,92	-	-	-	-	-	-	-	-	0,39	0,59	0,71	0,77
160L	0,72	0,87	0,91	0,92	0,56	0,76	0,83	0,86	0,53	0,73	0,82	0,86	0,37	0,58	0,70	0,77
180M	0,75	0,87	0,91	0,92	0,51	0,73	0,81	0,85	-	-	-	-	-	-	-	-
180L	-	-	-	-	0,56	0,76	0,83	0,86	0,48	0,70	0,79	0,84	0,39	0,61	0,74	0,79
200L/L ₁	0,65	0,83	0,88	0,90	0,60	0,79	0,86	0,88	0,51	0,72	0,8	0,84	0,40	0,60	0,74	0,80
200L ₂	0,68	0,85	0,89	0,91	-	-	-	-	0,50	0,71	0,82	0,85	-	-	-	-
225S	-	-	-	-	0,63	0,82	0,87	0,88	-	-	-	-	0,40	0,62	0,73	0,79
225M	0,65	0,84	0,88	0,90	0,62	0,81	0,86	0,88	0,52	0,72	0,81	0,84	0,39	0,61	0,73	0,79
250M	0,66	0,83	0,88	0,90	0,64	0,82	0,88	0,89	0,53	0,74	0,82	0,84	0,47	0,69	0,78	0,82
280S	0,69	0,85	0,89	0,90	0,62	0,80	0,85	0,86	0,53	0,74	0,80	0,82	0,45	0,66	0,77	0,82
280M	0,70	0,86	0,90	0,91	0,62	0,80	0,85	0,86	0,53	0,74	0,81	0,82	0,45	0,68	0,78	0,82
315S	0,76	0,89	0,90	0,91	0,63	0,81	0,85	0,86	0,58	0,78	0,85	0,87	0,46	0,68	0,78	0,83
315M	0,75	0,88	0,90	0,91	0,62	0,80	0,85	0,86	0,62	0,81	0,87	0,88	0,47	0,69	0,79	0,83
315L ₁	0,73	0,87	0,90	0,91	0,59	0,79	0,85	0,86	0,60	0,80	0,86	0,88	0,47	0,68	0,79	0,83
315L ₂	0,75	0,88	0,91	0,92	0,58	0,78	0,85	0,87	0,62	0,81	0,86	0,88	0,47	0,68	0,78	0,82
315L ₃	0,79	0,87	0,91	0,92	0,64	0,80	0,85	0,87	0,61	0,80	0,86	0,88	0,48	0,69	0,78	0,82
355M	-	-	-	-	-	-	-	-	0,60	0,80	0,86	0,88	0,45	0,67	0,78	0,83
355L/L ₁	0,83	0,91	0,92	0,92	0,67	0,84	0,88	0,89	0,61	0,81	0,85	0,88	0,46	0,67	0,78	0,82
355L ₂	0,83	0,91	0,92	0,93	0,70	0,85	0,89	0,90	0,61	0,81	0,86	0,88	0,48	0,69	0,79	0,82
355L ₃	0,83	0,91	0,92	0,93	0,70	0,85	0,89	0,90	-	-	-	-	-	-	-	-

The figures are also valid for series BD...

Mains Operation 60 Hz

68

Temperature class T4, ns = 3600 rpm, 2p = 2

Type	Output	Rated current at 460V	Speed	Efficiency	Power factor	Torque	Starting torque	Starting current	Stalling torque	Mass inertia	Weight ¹⁾	Noise values with radial-flow fan		Noise values with axial-flow fan Typ ... A	
CD...	P ₂ [kW]	I [A]	n [rpm]	η [%]	cos φ	M [Nm]	M _A /M _N	I _A /I _N	M _K /M _N	J [kgm ²]	m [kg]	L _p [dB(A)]	L _w [dB(A)]	L _p [dB(A)]	L _w [dB(A)]
63K-2	0,21	0,59	3485	66	0,68	0,58	4,6	6,8	6,5	0,00028	16	53	65		
63L-2	0,29	0,68	3430	70	0,77	0,81	3,4	5,8	4,7	0,00028	16	53	65		
71K-2	0,44	0,92	3360	71,5	0,84	1,25	2,7	5,2	3,5	0,00028	16	56	68	on request	
71L-2	0,65	1,33	3370	73	0,84	1,83	2,8	5,5	3,6	0,00039	17	56	68		
80K-2	0,86	1,74	3350	74	0,84	2,45	2,7	4,8	3,3	0,00058	24	60	72		
80L-2	1,26	2,4	3385	78	0,85	3,55	2,8	5,5	3,5	0,0008	25	60	72		
90L ₁ -2	1,8	3,35	3410	79	0,86	5	2,7	5,5	3,2	0,0013	31	65	77		
90L ₂ -2	2,5	4,45	3420	82	0,86	7	2,7	5,6	3,3	0,0018	35	65	77		
100L-2	3,6	6,3	3420	83	0,87	10,1	2,7	6,8	3,3	0,0029	45	68	80		
112M-2	4,8	8,1	3455	85	0,88	13,3	2,3	6,5	3,1	0,0051	53	68	80		
132S ₁ -2	6,6	11,2	3470	85	0,87	18,2	2,5	6	3,3	0,0089	95	68	81		
132S ₂ -2	9	15	3490	86,5	0,87	24,6	2,7	6,8	3,5	0,0125	100	68	81		
160M ₁ -2	12,8	20,5	3510	88,5	0,89	34,8	2,8	6,6	3,2	0,032	163	71	84		
160M ₂ -2	17,5	26,5	3505	89,5	0,92	48	2,8	6,7	3,2	0,043	173	71	84		
160L-2	22	33	3510	91	0,92	60	2,6	6,7	3,1	0,052	188	71	84		
180M-2	26	39	3510	91,5	0,92	71	2,5	6,9	3	0,075	196	75	88		
200L ₁ -2	36	54	3545	92,2	0,9	97	2,6	7,2	2,9	0,13	254	77	91		
200L ₂ -2	43	65	3545	92,7	0,9	116	2,7	7,2	3	0,16	278	77	91		
225M-2	52	79	3550	92,7	0,89	140	2,5	7,1	3	0,24	400	78	92		
250M-2	64	97	3565	93,5	0,89	171	2,4	7,1	2,8	0,4	545	81	95		
280S-2	87	129	3565	94	0,9	233	2,2	6,8	2,7	0,65	700	82	96		
280M-2	105	156	3565	94	0,9	281	2,4	6,6	2,8	0,78	762	82	96		
315S-2	121	179	3570	94,5	0,9	324	2,1	6,6	2,5	1,4	960	85	100		
315M-2	145	215	3570	95	0,9	388	2,2	7,2	2,6	1,6	1025	85	100		
315L ₁ -2	176	260	3570	95,2	0,9	471	2,5	7,3	2,8	1,7	1065	85	100		
315L ₂ -2	220	320	3575	95,4	0,9	588	2,4	7,3	2,7	2,2	1270	85	100		
315L ₃ -2	275	395	3580	95,5	0,92	735	1,8	7,6	2,8	2,8	1420	85	100		
355L ₁ -2	345	on request													
355L ₂ -2	390														
400M-2	440	on request													

Note

1) Version B3 with terminal box

The figures are also valid for series BD...

Temperature class T4, ns = 1800 rpm, 2p = 4

Type	Output	Rated current at 460V	Speed	Efficiency	Power factor	Torque	Starting torque	Starting current	Stalling torque	Mass inertia	Weight ²⁾	Noise values with radial-flow fan		Noise values with axial-flow fan Typ ... A	
CD...	P ₂ [kW]	I [A]	n [rpm]	η [%]	cos φ	M [Nm]	M _s /M _N	I _s /I _N	M _K /M _N	J [kgm ²]	m [kg]	L _p [dB(A)]	L _w [dB(A)]	L _p [dB(A)]	L _w [dB(A)]
63K-4	0,14	0,44	1735	67	0,6	0,77	3,9	5,6	3,9	0,0002	13	48	60		
63L-4	0,21	0,54	1700	70	0,7	1,18	2,7	4,7	2,7	0,00025	14	48	60		
71K-4	0,3	0,71	1645	66	0,8	1,74	2	3,9	2,5	0,00046	16	49	61	on request	
71L-4	0,44	0,99	1655	70	0,8	2,54	2,2	3,9	2,6	0,00063	17	49	61		
80K-4	0,63	1,35	1655	73	0,8	3,6	2	3,8	2,3	0,00092	24	50	62		
80L-4	0,86	1,85	1680	75	0,78	4,9	2,1	4,2	2,5	0,0013	25	50	62		
90L ₁ -4	1,3	2,55	1680	76	0,84	7,4	2,1	4,8	2,5	0,0021	31	53	65		
90L ₂ -4	1,8	3,45	1685	79	0,83	10,2	2,3	5	2,7	0,0029	35	53	65		
100L ₁ -4	2,6	5,1	1705	80	0,8	14,6	2,4	5,4	2,8	0,0046	44	57	69		
100L ₂ -4	3,6	6,8	1700	80,5	0,82	20,2	2,3	5,5	2,7	0,0056	46	57	69		
112M-4	4,8	8,4	1720	85	0,84	26,7	2,7	6,8	3,2	0,011	59	59	71		
132S-4	6,6	11,1	1730	86,5	0,86	36,4	2,5	6,2	2,7	0,022	100	62	75		
132M-4	8,5	14,1	1730	88	0,86	47	2,7	6,5	2,8	0,03	110	62	75		
160M-4	12,6	21	1750	89,5	0,85	69	2,5	6,6	2,8	0,057	168	67	80		
160L-4	17,2	28	1745	90	0,86	94	2,8	6,5	3,1	0,079	184	67	80		
180M-4	22	36	1750	91	0,84	120	2,9	6,6	3	0,13	198	65	78		
180L-4	26	42	1750	91,5	0,85	142	3	6,9	3	0,155	217	65	78		
200L-4	34,5	53	1750	92,5	0,88	188	2,6	6,8	2,9	0,25	274	66	80		
225S-4	43	65	1760	93	0,89	233	2,7	6,7	2,6	0,4	372	68	82		
225M-4	52	79	1765	93	0,89	281	2,7	6,5	2,6	0,48	402	68	82		
250M-4	64	96	1765	93,8	0,89	346	2,9	7,1	2,9	0,75	573	70	84		
280S-4	87	134	1775	94,5	0,86	468	2,6	6,8	2,5	1,25	740	74	88		
280M-4	105	162	1775	94,5	0,86	565	2,8	6,9	2,6	1,48	820	74	88		
315S-4	121	186	1780	95,1	0,86	649	2,6	7,1	2,7	2,2	1040	76	91		
315M-4	145	22	1780	95,3	0,86	778	2,6	7,2	2,8	2,7	1120	76	91		
315L ₁ -4	176	265	1780	95,6	0,87	944	2,7	7,3	2,7	3,1	1210	76	91		
315L ₂ -4	220	330	1780	95,8	0,87	1180	2,7	7,3	2,7	3,9	1430	76	91		
315L ₃ -4	275	405 ¹⁾	1785	96	0,89	1471	1,8	7,7	2,8	4,6	1565	76	91		
355L ₁ -4	345	505 ¹⁾	1790	96,3	0,89	1841	1,6	7,3	2,8	6,1	2050	78	94		
355L ₂ -4	390	570 ¹⁾	1790	96,6	0,89	2081	1,7	7,3	3	6,7	2200	78	94		
400S-4	440	635 ¹⁾	1794	97	0,9	2342	1,4	7,1	3	16	2650	84	100		
400M-4	495	705 ¹⁾	1794	97	0,91	2635	1,15	6,9	2,8	18	2850	84	100		
450S-4	550	780 ¹⁾	1794	97,2	0,91	2928	1,05	7,3	2,8	23	3300	85	101		
450M-4	610		1794	97,4	0,91	3247	1,05	7,2	2,8	26	3500	85	101		
450L-4	690		1794	97,4	0,91	3673	1,05	7,2	2,8	26	3800	85	101		
500...	on request														

Note

1) Two parallel feeds are necessary in each case

2) Version B3 with terminal box

The figures are also valid for series BD...

Mains Operation 60 Hz

70

Temperature class T4, ns = 1200 rpm, 2p = 6

Type	Output	Rated current at 460V	Speed	Efficiency	Power factor	Torque	Starting torque	Starting current	Stalling torque	Mass inertia	Weight ²⁾	Noise values with radial-flow fan	
CD...	P ₂ [kW]	I [A]	n [rpm]	η [%]	cos φ	M [Nm]	M _s /M _N	I _s /I _N	M _K /M _N	J [kgm ²]	m [kg]	L _p [dB(A)]	L _w [dB(A)]
71L-6	0,3	0,86	1105	62	0,71	2,6	2,2	3,5	2,6	0,0012	17	48	60
80K-6	0,42	1,11	1110	67	0,71	3,6	2,5	4,1	2,8	0,0019	24	48	60
80L-6	0,64	1,62	1110	69	0,72	5,5	2,4	4	2,7	0,0025	25	48	60
90L ₁ -6	0,9	2,25	1090	67	0,75	7,9	1,8	3,4	2,1	0,0033	31	51	63
90L ₂ -6	1,3	3,15	1105	71	0,73	11,2	2	3,7	2,2	0,0046	35	51	63
100L-6	1,8	3,9	1135	77	0,75	15,1	2,4	5	2,9	0,0095	46	54	66
112M-6	2,6	5,4	1140	81	0,75	21,8	2,7	5,6	3,1	0,017	59	58	70
132S-6	3,6	6,9	1160	84	0,78	29,6	2,7	6,3	3,1	0,031	100	61	74
132M ₁ -6	4,8	9	1150	85	0,79	40	2,6	6	3	0,037	104	61	74
132M ₂ -6	6,6	11,9	1150	86	0,81	55	2,6	6,4	3	0,043	112	61	74
160M-6	8,6	14,6	1150	86,8	0,85	71	2,5	6,8	3,3	0,087	170	63	76
160L-6	12,6	21	1160	87,5	0,86	104	2,5	6,7	3,2	0,12	190	63	76
180L-6	18	30	1160	90	0,84	148	2,4	6,9	3,2	0,19	215	63	76
200L ₁ -6	21,3	35	1170	90,5	0,84	174	1,9	6,2	2,7	0,28	270	63	77
200L ₂ -6	26	42	1165	91	0,85	213	2,2	6,8	3	0,31	280	63	77
225M-6	35	57	1170	92	0,84	286	2,8	6,6	2,5	0,69	404	67	81
250M-6	44	71	1175	92,5	0,84	358	2,8	6,6	2,6	1,03	570	68	82
280S-6	52	84	1180	93,5	0,83	421	2,8	5,8	2,4	1,35	720	70	84
280M-6	64	105	1180	93,5	0,82	518	2,7	5,8	2,3	1,7	770	70	84
315S-6	87	134	1190	94	0,87	698	2,6	6,4	2,4	4,3	995	75	90
315M-6	105	159	1190	94,2	0,88	842	2,6	6,5	2,4	5	1050	75	90
315L ₁ -6	121	183	1190	94,5	0,88	971	2,8	6,9	2,6	6	1145	75	90
315L ₂ -6	145	220	1190	94,7	0,88	1164	2,8	7,1	2,6	7,3	1265	75	90
315L ₃ -6	176	265	1190	95	0,88	1412	2,7	7,2	2,6	8,3	1440	75	90
355M-6	220	330	1190	95,5	0,88	1766	1,9	7,1	2,8	11,3	1750	80	96
355L ₁ -6	275	410 ¹⁾	1190	95,9	0,88	2207	1,9	7,1	2,8	13,8	1950	80	96
355L ₂ -6	345	515 ¹⁾	1190	96	0,88	2769	1,8	7,3	2,7	17,6	2300	80	96
400M-6	390	570 ¹⁾	1193	96,6	0,89	3122	1,15	7	2,8	27	2850	84	100
400L-6	440	640 ¹⁾	1193	96,6	0,89	3522	1,05	7,3	2,7	41	3230	84	100
450M-6	495	725 ¹⁾	1194	96,6	0,89	3959	1,3	7,2	3	46	3500	84	100
450L-6	550	800 ¹⁾	1194	97	0,89	4399	1,15	7,2	2,8	51	3800	84	100
500...	on request												

Note

- 1) Two parallel feeds are necessary in each case
- 2) Version B3 with terminal box

The figures are also valid for series BD...

Type	Output	Rated current at 460V	Speed	Efficiency	Power factor	Torque	Starting torque	Starting current	Stalling torque	Mass inertia	Weight ²⁾	Noise values with radial-flow fan	
CD...	P ₂ [kW]	I [A]	n [rpm]	η [%]	cos φ	M [Nm]	M _A /M _N	I _A /I _N	M _K /M _N	J [kgm ²]	m [kg]	L _p [dB(A)]	L _w [dB(A)]
71L-8	0,14	0,5	815	52	0,67	1,64	1,9	2,4	2,4	0,0012	17	45	57
80K-8	0,21	0,66	830	61	0,65	2,4	2,2	3,2	2,6	0,0019	24	46	58
80L-8	0,3	0,95	830	62	0,64	3,45	2,2	3,2	2,5	0,0025	25	46	58
90L ₁ -8	0,44	1,35	850	63	0,65	4,9	1,8	3	2,2	0,0033	31	50	62
90L ₂ -8	0,64	1,87	835	67	0,64	7,3	1,8	3,1	2,2	0,0046	35	50	62
100L ₁ -8	0,9	2,4	850	71	0,66	10,1	2,4	4	2,6	0,008	44	53	65
100L ₂ -8	1,3	3,25	835	69	0,73	14,9	2	3,8	2,4	0,0095	46	53	65
112M-8	1,8	4,3	850	78	0,67	20,2	2,2	4,6	2,8	0,017	59	57	69
132S-8	2,6	5,2	835	80	0,79	29,7	2	4,1	2,3	0,029	97	58	71
132M-8	3,6	7,2	845	81	0,77	41	2,4	4,6	2,7	0,036	113	58	71
160M ₁ -8	4,6	8,7	860	85	0,78	51	1,8	4,6	2,3	0,071	157	59	72
160M ₂ -8	6,5	12,3	865	86	0,77	72	2,1	5,4	2,8	0,105	170	59	72
160L-8	9	17	865	86,5	0,77	99	2,2	5,6	2,9	0,136	190	59	72
180L-8	13,2	23,5	870	89	0,79	145	2,4	6,4	3	0,22	215	61	74
200L-8	18	31,5	875	89,5	0,79	196	2,7	6,9	3,2	0,4	280	61	75
225S-8	22	39	875	90	0,79	240	2,2	6,3	3	0,56	372	62	76
225M-8	26	45,5	875	91	0,79	284	2,2	6,3	3	0,69	404	62	76
250M-8	36	60	885	92,5	0,82	391	2	6,8	3	1,2	550	63	77
280S-8	44	73	880	92,8	0,82	478	2,1	6,2	2,8	1,9	740	66	80
280M-8	52	85	880	92,8	0,83	564	2	6,3	2,6	2,3	800	66	80
315S-8	61	100	885	92,5	0,83	658	2,5	6	2,6	4,3	995	74	89
315M-8	87	141	885	93	0,83	939	2,5	6,3	2,5	5	1050	74	89
315L ₁ -8	105	170	885	93,2	0,83	1133	2,6	6,6	2,6	6	1145	74	89
315L ₂ -8	121	199	885	93,2	0,82	1306	2,8	7,2	2,8	7,3	1265	74	89
315L ₃ -8	145	240	880	93,4	0,82	1574	2,6	6,6	2,6	8,3	1440	74	89
355M-8	176	280	890	95,1	0,83	1889	2	6,7	2,5	11,4	1750	76	92
355L ₁ -8	220	355	895	95,5	0,82	2347	1,8	7	2,6	13,9	1950	76	92
355L ₂ -8	275	440 ¹⁾	895	95,6	0,82	2934	1,8	7,1	2,6	17,7		76	92
400M-8	345	540 ¹⁾	895	96,2	0,83	3681	1,3	6,5	2,5	30	3100	79	95
400L-8	390	610 ¹⁾	895	96,3	0,84	4161	1,05	6,4	2,4	34		79	95
450M-8	440	680 ¹⁾	895	96,6	0,84	4695	1,05	6,4	2,3	51	3750	80	96
450L-8	495	765 ¹⁾	895	96,7	0,84	5282	1,05	6,4	2,3	57	4050	80	96
500...	on request												

Note

- 1) Two parallel feeds are necessary in each case
- 2) Version B3 with terminal box

The figures are also valid for series BD...



Mains operation 50 Hz Increased Output

72

Temperature class T4, ns = 3000 rpm, 2p = 2

40 °C ambient temperature, winding temperature rise F

Type	Output	Rated current at		Speed	Efficiency	Power factor	Torque	Starting torque	Starting current	Stalling torque	Mass inertia	Weight ¹⁾	Noise values with radial-flow fan	
		400V	500V										n	η
CD...X	P_2 [kW]	I [A]	I [A]	n [rpm]	η [%]	$\cos \phi$	M [Nm]	M_A/M_N	I_A/I_N	M_K/M_N	J [kgm ²]	m [kg]	L_p [dB(A)]	L_w [dB(A)]
63K-2	0,25	0,69	0,55	2860	70	0,75	0,83	3,4	5,8	4,7	0,00028	16	49	61
63L-2	0,37	0,89	0,71	2800	71,5	0,84	1,26	2,7	5,2	3,5	0,00028	16	49	61
71K-2	0,46	1,43	1,15	2720	66	0,84	1,62	2,1	4,2	2,5	0,00028	16	57	69
71L-2	0,75	1,91	1,53	2730	70	0,81	2,62	2,7	4,7	3,2	0,00039	17	57	69
80K-2	1	2,65	2,1	2750	68	0,80	3,47	2,4	4,2	3	0,00058	24	59	71
80L-2	1,4	3,3	2,65	2805	76,5	0,80	4,8	3,2	5,6	3,6	0,0008	25	59	71
90L ₁ -2	1,9	4,2	3,35	2830	78	0,84	6,4	2,2	5,8	3,1	0,0013	31	60	72
90L ₂ -2	2,7	6,2	4,95	2830	78	0,81	9,1	2,5	5,5	3,5	0,0018	35	60	72
100L-2	3,4	7,5	6	2845	80	0,82	11,4	2,8	5,8	3,5	0,0029	45	64	76
112M-2	5	9,9	7,9	2870	83,5	0,87	16,6	2,3	6,8	3	0,0051	53	66	78
132S ₁ -2	6,6	14,3	11,4	2880	81,5	0,82	21,9	2,4	6	3,1	0,0089	95	69	82
132S ₂ -2	9	18,7	15	2910	83,5	0,83	29,5	2,7	6,8	3,5	0,0125	100	69	82
160M ₁ -2	13,5	26	21	2920	86	0,87	44	2,5	6,5	3,2	0,032	163	80	93
160M ₂ -2	18,5	34,5	27,5	2910	87,5	0,89	61	2,5	6,5	3,2	0,043	173	80	93
160L-2	22	39,5	31,5	2915	89	0,90	72	2,8	6,9	3,4	0,052	188	80	93
180M-2	30	55	44	2915	89,5	0,88	98	2,7	6,9	3,1	0,075	196	83	96
200L ₁ -2	37	66	53	2955	91,4	0,89	120	3	7,2	3,3	0,13	254	85	99
200L ₂ -2	45	81	65	2955	92	0,87	145	2,8	7,2	3,3	0,16	278	85	99
225M-2	55	102	81	2965	92	0,85	177	2,9	7,1	3,7	0,24	400	87	101
250M-2	70	139	111	2970	91	0,80	225	2,9	7,2	3,5	0,4	545	87	101
280S-2	90	162	130	2970	92	0,87	289	2,2	6,6	2,7	0,65	700	89	103
280M-2	110	195	156	2970	92,4	0,88	354	2	6,9	2,5	0,78	762	89	103
315S-2	132	230	185	2975	93,6	0,88	242	1,9	6,5	2,3	1,4	960	90	105
315M-2	160	280	225	2975	93	0,89	514	1,8	6,7	2,4	1,6	1025	90	105
315L ₁ -2	200	320	255	2975	93,5	0,89	594	2	6,9	2,6	1,9	1065	90	105
315L ₂ -2	230	400	320	2975	93,5	0,89	738	2	6,9	2,6	2,2	1270	90	105

Note

1) Version B3 with terminal box

The figures are also valid for series BD...

Temperature class T4, ns = 1500 rpm, 2p = 4

40 °C ambient temperature, winding temperature rise F

Type	Output P ₂ [kW]	Rated current at		Speed n [rpm]	Efficiency η [%]	Power factor cos φ	Torque M [Nm]	Starting torque M _A /M _N	Starting current I _A /I _N	Stalling torque M _K /M _N	Mass inertia J [kgm ²]	Weight ²⁾ m [kg]	Noise values with radial-flow fan		
		400V I [A]	500V I [A]										L _p [dB(A)]	L _w [dB(A)]	
CD...X															
63K-4	0,18	0,53	0,42	1415	70	0,70	1,2	2,7	4,7	2,7	0,00046	16	44	56	
63L-4	0,25	0,66	0,53	1370	68,5	0,80	1,74	2	3,9	2,5	0,00046	16	44	56	
71K-4	0,37	1,03	0,82	1350	65	0,80	2,62	1,7	3,6	2,3	0,00046	16	46	58	
71L-4	0,5	1,42	1,15	1335	67	0,79	3,58	2,1	3,6	2,7	0,0063	17	46	58	
80K-4	0,7	1,99	1,59	1310	65	0,78	5,1	2	3,5	2,2	0,00092	24	47	59	
80L-4	1	2,7	2,15	1350	70	0,77	7,1	2,3	4,1	2,5	0,0013	25	47	59	
90L ₁ -4	1,4	3,25	2,6	1380	75,5	0,83	9,7	2	4,9	2,5	0,0021	31	49	61	
90L ₂ -4	2	4,6	3,7	1360	75	0,83	14	2	4,2	2,2	0,0029	35	49	61	
100L ₁ -4	2,5	6,2	4,9	1415	76	0,77	16,9	2,3	5,7	2,7	0,0046	44	52	64	
100L ₂ -4	3,4	7,6	6,1	1400	78,8	0,82	23,2	2,1	5,5	2,8	0,0056	46	52	64	
112M-4	5	11,1	8,9	1420	81	0,80	33,6	2,6	6,4	3	0,011	59	54	66	
132S-4	6,6	13,4	10,7	1435	83,6	0,85	44	2,6	6,3	2,9	0,022	100	59	72	
132M-4	9	18,3	14,6	1435	85,7	0,83	60	2,7	6,3	3	0,03	110	59	72	
160M-4	13,5	27,5	22	1460	87,5	0,81	88	2,6	6,9	3	0,057	168	67	80	
160L-4	17,5	34	27	1455	88,6	0,84	115	2,5	6,8	2,9	0,079	184	67	80	
180M-4	22	43,5	35	1460	90	0,81	144	3,1	6,7	3,2	0,13	198	73	86	
180L-4	27	52	42	1460	91	0,82	177	3	7,2	3,1	0,155	217	73	86	
200L-4	37	68	55	1460	91	0,86	242	2,9	7,2	3	0,25	274	76	90	
225S-4	45	81	65	1465	92	0,87	293	2,6	6,1	2,6	0,4	372	79	93	
225M-4	55	100	80	1475	92,5	0,86	356	2,6	6,5	2,8	0,48	402	79	93	
250M-4	70	127	102	1475	92,5	0,86	453	2,9	7,2	3,4	0,75	573	80	94	
280S-4	90	164	131	1480	93,2	0,85	581	2,7	6,8	2,8	1,25	740	82	96	
280M-4	110	200	161	1480	93,7	0,84	710	2,9	6,9	3,1	1,48	820	82	96	
315S-4	132	245	194	1480	93,5	0,84	851	2,2	6,5	2,4	2,2	1040	84	99	
315M-4	160	290	230	1480	94	0,85	1032	2,4	6,5	2,6	2,7	1120	84	99	
315L ₁ -4	200	355	285	1485	94,7	0,86	1190	2,5	6,9	2,6	3,3	1210	84	99	
315L ₂ -4	230	410 ¹⁾	325	1485	94,7	0,86	1479	2,5	6,9	2,7	3,9	1430	84	99	

Note

1) Two parallel feeds are necessary in each case

2) Version B3 with terminal box

The figures are also valid for series BD...

Mains Operation 60 Hz Increased Output

74

Temperature class T4, ns = 3600 rpm, 2p = 2

40 °C ambient temperature, winding temperature rise F

Type	Output	Rated current at	Speed	Efficiency	Power factor	Torque	Starting torque	Starting current	Stalling torque	Mass inertia	Weight ¹⁾	Noise values with radial-flow fan	
CD...X	P ₂ [kW]	460V I [A]	n [rpm]	η [%]	cos φ	M [Nm]	M _s /M _N	I _s /I _N	M _K /M _N	J [kgm ²]	m [kg]	L _p [dB(A)]	L _w [dB(A)]
63K-2	0,29	0,69	3430	70	0,75	0,81	3,4	5,8	4,7	0,00028	16	53	65
63L-2	0,44	0,92	3360	71,5	0,84	1,25	2,7	5,2	3,5	0,00028	16	53	65
71K-2	0,53	1,45	3265	66	0,84	1,55	2,1	4,2	2,5	0,00028	16	61	73
71L-2	0,87	1,93	3375	70	0,81	2,46	2,7	4,7	3,2	0,00039	17	61	73
80K-2	1,16	2,7	3300	68	0,80	3,36	2,4	4,2	3	0,00058	24	63	75
80L-2	1,6	3,3	3410	76,5	0,80	4,5	3,2	5,9	3,6	0,0008	25	63	75
90L ₁ -2	2,2	4,2	3395	78	0,84	6,3	2,2	5,8	3,1	0,0013	31	64	76
90L ₂ -2	3,1	6,2	3395	78	0,81	8,7	2,5	5,5	3,5	0,0018	35	64	76
100L-2	3,9	7,5	3415	80	0,82	10,9	2,8	5,8	3,5	0,0029	45	68	80
112M-2	5,8	10	3445	83,5	0,87	16,1	2,3	6,8	3	0,0051	53	70	82
132S ₁ -2	7,6	14,3	3455	81,5	0,82	21	2,4	6	3,1	0,0089	95	73	86
132S ₂ -2	10,4	18,8	3495	83,5	0,83	28,4	2,7	6,8	3,5	0,0125	100	73	86
160M ₁ -2	15,5	26	3505	86	0,87	42	2,5	6,5	3,2	0,034	163	85	98
160M ₂ -2	22	35,5	3490	87,5	0,89	60	2,5	6,5	3,2	0,043	173	85	98
160L-2	26	41	3500	89	0,90	71	2,8	6,9	3,4	0,052	188	85	98
180M-2	35	56	3500	89,5	0,88	96	2,7	6,9	3,1	0,075	196	88	101
200L ₁ -2	43	66	3545	91,4	0,89	116	3	7,2	3,3	0,13	254	90	104
200L ₂ -2	52	82	3545	92	0,87	140	2,8	7,2	3,3	0,16	278	90	104
225M-2	64	103	3560	92	0,85	172	2,9	7,1	3,7	0,24	400	92	106
250M-2	81	140	3565	91	0,80	217	2,9	7,2	3,5	0,4	545	92	106
280S-2	105	165	3565	92	0,87	281	2,2	6,6	2,7	0,65	700	95	109
280M-2	121	187	3565	92,4	0,88	324	2,1	7,3	2,6	0,78	762	95	109
315S-2	145	220	3570	93,6	0,88	388	2	6,9	2,4	1,4	960	96	111
315M-2	176	265	3570	93	0,89	471	1,9	7,1	2,5	1,6	1025	96	111
315L ₁ -2	220	330	3570	93,5	0,89	548	2,1	7,3	2,7	1,9	1065	96	111
315L ₂ -2	255	385	3570	93,5	0,89	682	2,1	7,3	2,7	2,2	1270	96	111

Note

1) Version B3 with terminal box

Temperature class T4, ns = 1800 rpm, 2p = 4

40 °C ambient temperature, winding temperature rise F

Type	Output	Rated current at	Speed	Efficiency	Power factor	Torque	Starting torque	Starting current	Stalling torque	Mass inertia	Weight ¹⁾	Noise values with radial-flow fan	
CD...X	P ₂ [kW]	460V I [A]	n [rpm]	η [%]	cos φ	M [Nm]	M _A /M _N	I _A /I _N	M _K /M _N	J [kgm ²]	m [kg]	L _p [dB(A)]	L _w [dB(A)]
63K-4	0,21	0,54	1700	70	0,70	1,18	2,7	4,7	2,7	0,00046	16	48	60
63L-4	0,3	0,69	1645	68,50	0,80	1,74	2	3,9	2,5	0,00046	16	48	60
71K-4	0,43	1,05	1620	65	0,80	2,53	1,7	3,6	2,3	0,00046	16	49	61
71L-4	0,58	1,38	1600	67	0,79	3,46	2,1	3,6	2,7	0,0063	17	49	61
80K-4	0,81	2	1570	65	0,78	4,9	2	3,5	2,2	0,00092	24	50	62
80L-4	1,16	2,7	1620	70	0,77	6,8	2,3	4,1	2,5	0,0013	25	50	62
90L ₁ -4	1,6	3,2	1680	75,5	0,83	9,1	2	4,9	2,5	0,0021	31	52	64
90L ₂ -4	2,3	4,6	1670	75,5	0,83	13,2	2	4,2	2,2	0,0029	35	52	64
100L ₁ -4	2,9	6,2	1705	76	0,77	16,2	2,3	5,7	2,7	0,0046	44	55	67
100L ₂ -4	3,9	7,3	1680	78,8	0,85	22,2	2,1	5,5	2,8	0,0056	46	55	67
112M-4	5,8	11,2	1705	81	0,80	32,5	2,6	6,4	3	0,011	59	57	69
132S-4	7,6	13,4	1720	83,6	0,85	42	2,6	6,3	2,9	0,022	100	63	76
132M-4	10,4	18,4	1720	85,7	0,83	58	2,7	6,3	3	0,03	110	63	76
160M-4	15,5	27,5	1750	87,5	0,81	85	2,6	6,9	3	0,057	168	71	84
160L-4	20	33,5	1745	88,6	0,84	109	2,5	6,8	2,9	0,079	184	71	84
180M-4	26	45	1750	90	0,81	142	3,1	6,7	3,2	0,13	198	76	89
180L-4	31	52	1750	91	0,82	169	3	7,2	3,1	0,155	217	76	89
200L-4	43	69	1750	91	0,86	235	2,9	7,2	3	0,25	274	81	95
225S-4	52	82	1760	92	0,87	282	2,6	6,1	2,6	0,4	372	84	98
225M-4	64	101	1770	92,5	0,86	345	2,6	6,5	2,8	0,48	402	84	98
250M-4	81	128	1770	92,5	0,86	437	2,9	7,2	3,4	0,75	573	85	99
280S-4	105	166	1775	93,2	0,85	565	2,7	6,8	2,8	1,25	740	87	101
280M-4	121	193	1775	93,7	0,84	651	3,1	7,3	3,3	1,48	820	87	101
315S-4	145	230	1775	93,5	0,84	780	2,3	6,9	2,5	2,2	1040	89	104
315M-4	176	276	1775	94	0,85	947	2,5	6,9	2,7	2,7	1120	89	104
315L ₁ -4	220	340	1780	94,7	0,86	1100	2,6	7,3	2,7	3,3	1210	89	104
315L ₂ -4	255	395	1780	94,7	0,86	1368	2,6	7,3	2,8	3,9	1430	89	104

Note

1) Version B3 with terminal box

Mains Operation 50 Hz/60 Hz

Temperature Class T6

76

Output at T6

Frame size CD...	50 Hz				60 Hz			
	2p = 2 3000 rpm P ₂ [kW]	2p = 4 1500 rpm P ₂ [kW]	2p = 6 1000 rpm P ₂ [kW]	2p = 8 750 rpm P ₂ [kW]	2p = 2 3600 rpm P ₂ [kW]	2p = 4 1800 rpm P ₂ [kW]	2p = 6 1200 rpm P ₂ [kW]	2p = 8 900 rpm P ₂ [kW]
63K	0,18	0,12	-	-	0,21	0,14	-	-
63L	0,25	0,18	-	-	0,29	0,21	-	-
71K	0,37	0,25	-	-	0,44	0,3	-	-
71L	0,55	0,37	0,25	0,12	0,65	0,44	0,25	0,14
80K	0,75	0,55	0,37	0,18	0,86	0,63	0,42	0,21
80L	1,1	0,75	0,55	0,25	1,26	0,86	0,64	0,29
90L ₁	1,5	1,1	0,65	0,37	1,8	1,3	0,75	0,43
90L ₂	2,2	1,4	0,85	0,55	2,5	1,6	1	0,64
100L ₁	-	1,8	-	0,75	-	2,1	-	0,87
100L/L ₂	2,5	2,2	1,3	0,95	2,9	2,3	1,5	1,1
112M	3,5	3,5	2	1,3	4	4	2,3	1,5
132S/S ₁	5,5	5	3	1,9	5,8	5,8	3,5	2,2
132S ₂	6	-	-	-	7	-	-	-
132M/M ₁	-	6	4	2,5	-	7	4,6	2,9
132M ₂	-	-	4,7	-	-	-	5,4	-
160M/M ₁	9	9,5	6,5	3,5	10,5	11	7,5	4
160M ₂	12	-	-	5	14	-	-	5,8
160L	13	11	8,5	6,5	15	12,5	9,8	7,5
180M	15,5	14	-	-	18	16	-	-
180L	-	15	10	9,5	-	17,5	11,5	11
200L/L ₁	22	22	15	12	25,5	25,5	17,5	14
200L ₂	27	-	18	-	31	-	21	-
225S	-	30	-	15	-	34	-	17,5
225M	35	35	22	19	40	40	29	22
250M	39	40	33	27	45	46	38	31
280S	54	54	40	33	63	63	46	38
280M	65	65	45	40	75	75	52	46
315S	on request				on request			
315M								
315L ₁								
315L ₂								
315L ₃								
355L ₁	on request				on request			
355L ₂								
355L ₃								

The figures are also valid for series BD...

Mains Operation Pole-Changing Motors 50 Hz

Temperature class T4

ns = 1500/3000 rpm, 2p = 4/2

77

40 °C ambient temperature, winding temperature rise F

Type	Output	Rated current at		Speed n [rpm]	Efficiency η [%]	Power factor $\cos \varphi$	Torque M [Nm]	Starting torque M_A/M_N	Starting current I_A/I_N	Stalling torque M_K/M_N	Mass inertia J [kgm ²]	Weight ²⁾ m [kg]	Noise values with radial-flow fan	
		400V I [A]	500V I [A]										L_P [dB(A)]	L_W [dB(A)]
80K-4/2	0,5	1,43	1,14	1400	67,5	0,75	3,4	2	3,9	2,6	0,00111	24	47	59
	0,65	1,66	1,33	2810	63,5	0,89	2,2	2,2	4,2	3			65	77
80L-4/2	0,7	1,92	1,54	1400	70	0,75	4,8	2,1	4	2,7	0,00148	25	47	59
	0,85	2,15	1,71	2820	66	0,87	2,9	2,4	4,8	3,2			65	77
90L ₁ -4/2	1,1	2,7	2,15	1395	70	0,84	7,5	1,8	4,2	2,2	0,00238	31	52	64
	1,4	3,15	2,5	2820	70	0,92	4,7	1,9	4,9	3			69	81
90L ₂ -4/2	1,5	3,55	2,8	1400	74	0,83	10,2	2	4,7	2,3	0,00318	35	52	64
	1,9	4,1	3,25	2830	73	0,92	6,4	2,2	5,4	3			69	81
100L-4/2	2,6	5,9	4,7	1410	78	0,82	17,6	2	4,8	2,7	0,00608	46	55	67
	3,2	6,5	5,2	2870	78	0,91	10,6	2,1	5,8	3			75	87
112M-4/2	3,7	7,6	6,1	1430	82,5	0,85	24,7	2,2	6	3	0,0122	59	56	68
	4,4	8,9	7,1	2895	78,5	0,91	14,5	2,5	6,7	3,3			76	88
132S-4/2	5	10,5	8,4	1445	82	0,84	33	2,1	5,6	2,7	0,0238	100	62	75
	6	12,2	9,7	2910	79	0,90	19,7	2,5	6,6	3,2			80	93
132M-4/2	7	14,1	11,3	1450	86,5	0,83	46	2,7	6,5	3	0,0323	110	62	75
	9	17,5	14	2910	82,5	0,90	29,5	2,5	6,9	3,2			80	93
160M-4/2	9,5	18,7	14,9	1455	87,5	0,84	62	2,5	6	2,8	0,0625	168	57	70
	11	19,8	15,9	2930	87	0,92	36	2,7	6,8	3,1			68	81
160L-4/2	13	25	20	1455	88,5	0,84	85	2,3	6	2,8	0,085	184	57	70
	16	28,5	23	2930	87,5	0,92	52	2,6	6,8	3,2			68	81
180M-4/2	16,5	32	25,5	1460	89,5	0,83	108	2,8	6,5	2,7	0,13	198	58	71
	20	36,5	29	2930	88	0,90	65	2,8	6,9	3			69	82
180L-4/2	19	36,5	29,5	1465	90	0,83	124	3,1	6,5	2,9	0,155	217	58	71
	25	45,5	36	2940	88,5	0,90	81	3,1	6,8	3,2			69	82
200L-4/2	26	47	37,5	1470	91,5	0,87	169	2,8	6,6	3	0,25	274	60	74
	31	53	43	2955	90	0,93	100	2,7	7,1	3,5			73	87
225S-4/2	32	59	47	1470	91,5	0,86	208	2,6	6,5	2,5	0,4	372	61	75
	38	66	53	2955	90	0,92	123	2,6	7	3			74	88
225M-4/2	38	69	55	1470	92,5	0,86	247	2,8	6,5	2,7	0,48	402	61	75
	46	79	63	2955	91,5	0,92	149	2,8	7	3,2			74	88
250M-4/2	46	82	65	1470	92,5	0,88	299	2,7	6,5	2,8	0,75	573	63	77
	55	94	75	2955	91	0,93	178	2,9	7,1	3,3			76	90
280S-4/2	63	113	90	1480	93,5	0,86	407	2,8	6,5	2,5	1,25	740	65	79
	75	129	103	2975	92	0,91	241	2,6	7	3,1			78	92
280M-4/2	73	131	105	1485	93,5	0,86	469	2,8	6,5	2,6	1,48	820	65	79
	87	150	120	2970	92	0,91	280	2,4	7,1	3,2			78	92
315S-4/2	85	155	124	1485	94	0,84	547	2,5	6,5	2,4	2,2	1040	67	82
	100	174	139	2975	92	0,90	321	2,1	7	2,8			80	95
315M-4/2	100	179	143	1485	95	0,85	643	2,6	6,6	2,6	2,7	1120	67	82
	125	215	172	2975	92	0,91	401	2,3	7,1	3			80	95
315L ₁ -4/2	120	215	172	1485	95	0,85	772	2,6	6,5	2,4	3,3	1210	67	82
	150	260	205	2975	92	0,91	482	2,3	7	2,9			80	95
315L ₂ -4/2	145	260	205	1485	95	0,85	932	2,6	6,5	2,4	3,8	1430	67	82
	175	300	240	2975	92	0,91	562	2,3	7	2,9			80	95
355S-4/2	160	280	220	1485	95,5	0,87	1029	1,3	6,4	2,4	5,1	1800	70	86
	200	330	265	2980	94	0,93	641	1,4	6,9	2,7			82	98
355M ₁ -4/2	180	315	250	1485	95,5	0,87	1158	1,3	6,6	2,3	5,6	1900	70	86
	220	365	290	2980	94	0,93	705	1,3	7,1	2,6			82	98
355M ₂ -4/2	200	345	280	1485	95,5	0,87	1286	1,3	6,5	2,3	6	2050	70	86
	250	415	330	2985	94	0,93	800	1,3	7	2,6			82	98
355L-4/2	220	380	305	1485	96	0,87	1415	1,3	6,5	2,3	6,7	2200	70	86
	280	460 ¹⁾	370	2985	94,5	0,93	896	1,3	7	2,6			82	98

Note

- 1) Two parallel feeds are necessary in each case
- 2) Version B3 with terminal box

The figures are also valid for series BD...

Mains Operation Pole-Changing Motors 50 Hz

78

Temperature class T4

$n_s = 1000/1500 \text{ rpm}, 2p = 6/4$

40 °C ambient temperature, winding temperature rise F

Type	Output	Rated current at		Speed	Efficiency	Power factor	Torque	Starting torque	Starting current	Stalling torque	Mass inertia	Weight ¹⁾	Noise values with radial-flow fan	
		400V	500V										n	η
CD...	P_2 [kW]	I [A]	I [A]	n [rpm]	η [%]	$\cos \phi$	M [Nm]	M_A/M_N	I_A/I_N	M_K/M_N	J [kgm ²]	m [kg]	L_p [dB(A)]	L_w [dB(A)]
90L ₁ -6/4	0,45	1,5	1,2	940	62	0,70	4,6	1,6	3,5	2,3	0,0038	31	52	64
	0,65	1,77	1,42	1435	68	0,78	4,3	1,8	4,2	2,4			55	67
90L ₂ -6/4	0,6	1,83	1,47	940	63	0,75	6,1	1,6	3,1	2,1	0,0051	35	52	64
	0,9	2,15	1,72	1430	75,5	0,80	6	1,9	4,2	2,3			55	67
100L ₁ -6/4	0,9	2,55	2,05	945	67,5	0,76	9,1	1,7	3,9	2,2	0,008	44	53	65
	1,3	3,05	2,45	1450	76,5	0,80	8,6	1,8	5,9	2,8			57	69
100L ₂ -6/4	1,1	3,1	2,5	950	69	0,74	11,1	1,9	4	2,3	0,0105	46	53	65
	1,7	4	3,2	1445	76	0,81	11,2	1,9	5,5	2,4			57	69
112M-6/4	1,5	3,5	2,8	950	77,6	0,80	15,1	2	4,6	2,3	0,019	59	54	66
	2,4	5	4	1430	79	0,88	16	1,8	4,8	2,4			59	71
132S-6/4	2,2	5,2	4,2	960	75	0,81	21,9	1,6	4,6	2,1	0,033	104	59	72
	3,3	7,1	5,7	1450	78	0,86	21,7	1,7	5,9	2,3			62	75
132M-6/4	3	6,9	5,5	960	78	0,81	29,8	1,8	4,5	2,4	0,046	112	59	72
	4,5	9,1	7,2	1445	81,5	0,88	29,7	1,6	5,8	2,7			62	75
160M-6/4	4,5	9,8	7,9	970	80,5	0,82	44,3	2,1	6,5	2,9	0,095	170	64	77
	6,6	12,8	10,2	1445	82	0,91	43,6	1,8	6,4	2,7			70	83
160L-6/4	6,5	13,2	10,5	960	81	0,88	65	1,6	5,2	2,5	0,13	190	64	77
	9,5	17,7	14,2	1465	86	0,90	62	2,1	6,9	2,7			70	83
180L-6/4	11	22,5	18	975	86	0,82	108	2,4	7	3,2	0,155	215	56	69
	16	29	23,5	1465	88	0,90	104	2	6,9	2,6			63	76
200L-6/4	16	32,5	26	975	86,5	0,82	155	1,8	7	2,8	0,338	280	56	70
	24	43,5	35	1475	89	0,89	156	1,6	7	3,1			63	77
225S-6/4	21	39,5	31,5	975	89	0,86	206	2,6	6,1	2,3	0,4	372	60	74
	31	54	43	1470	90	0,92	201	2,1	6,6	2,8			67	81
225M-6/4	25	46,5	37	975	89,5	0,87	245	2,8	6	2,4	0,48	404	60	74
	37	64	51	1475	91	0,92	240	2,2	6,8	2,9			67	81
250M-6/4	32	59	47	975	90	0,87	313	2,7	6	2,5	0,75	570	61	75
	47	81	65	1475	91	0,92	304	2,2	6,4	2			68	82
280S-6/4	45	88	70	980	91	0,81	439	2,8	6,3	2,7	1,02	740	62	76
	66	118	86	1480	92,5	0,87	426	2,6	6,9	2,7			70	84
280M-6/4	54	107	86	980	91	0,80	526	2,8	6,7	2,7	1,27	820	62	76
	80	142	113	1475	92,5	0,88	518	2,6	7	3			70	84
315S-6/4	60	112	90	985	92	0,84	582	2	6,5	2,3	2,2	996	63	78
	85	147	117	1480	93	0,90	547	2,3	6,9	2,1			71	86
315M-6/4	70	130	104	985	92,5	0,84	679	2	6,5	2,3	2,7	1096	63	78
	100	172	138	1480	93	0,90	643	2,3	6,9	2,2			71	86
315L ₁ -6/4	85	163	130	985	93	0,81	824	2,2	6,8	2,6	3,3	1221	63	78
	120	205	164	1480	94	0,90	772	2,4	7	2,6			71	86
315L ₂ -6/4	100	182	145	985	93,5	0,85	970	2,2	6,8	2,4	3,9	1290	63	78
	140	235	189	1485	95	0,90	900	2,4	7	2,2			71	86
355S-6/4	110	192	154	985	94	0,88	1067	1,7	6,5	2,2	8,9	1750	83	83
	160	265	215	1485	95	0,91	1029	1,6	6,8	2			92	92
355M-6/4	130	225	181	985	94	0,88	1260	1,7	6,8	2,3	10,9	1950	83	83
	180	300	240	1485	95	0,91	1152	1,6	7	2,1			92	92
355L-6/4	150	260	210	990	94,5	0,88	1454	1,6	6,5	2,2	12,6	2200	83	83
	210	350	280	1485	95	0,91	1351	1,6	6,9	2,1			92	92

Note

1) Version B3 with terminal box

The figures are also valid for series BD...

Temperature class T4

ns = 750/1500 rpm, 2p = 8/4

40 °C ambient temperature, winding temperature rise F

Type	Output	Rated current at		Speed n [rpm]	Efficiency η [%]	Power factor $\cos \varphi$	Torque M [Nm]	Starting torque M_A/M_N	Starting current I_A/I_N	Stalling torque M_K/M_N	Mass inertia J [kgm ²]	Weight ¹⁾ m [kg]	Noise values with radial-flow fan	
		400V I [A]	500V I [A]										L_P [dB(A)]	L_W [dB(A)]
90L ₁ -8/4	0,4	1,48	1,18	675	56,5	0,69	5,7	1,5	2,7	2	0,0038	31	49	61
	0,6	1,4	1,12	1400	70,5	0,88	4,1	2	4,4	2,5			52	64
90L ₂ -8/4	0,55	2	1,61	680	58	0,68	7,7	1,7	3,3	2,2	0,0051	35	49	61
	0,8	1,87	1,5	1410	71	0,87	5,4	2	4,2	2,6			52	64
100L ₁ -8/4	0,9	3,05	2,45	690	60	0,71	12,5	1,6	3,1	2,1	0,008	44	52	64
	1,3	3,1	2,45	1395	67,5	0,90	8,9	1,6	4,2	2,2			55	67
100L ₂ -8/4	1	3,1	2,5	700	65,5	0,71	13,6	1,7	3,5	2,2	0,011	46	52	64
	1,6	3,5	2,8	1400	72	0,91	10,9	1,7	4,5	2,4			55	67
112M-8/4	1,5	4,6	3,65	710	72,6	0,65	20,2	2,1	4,2	2,2	0,019	59	52	64
	2,5	4,85	3,85	1420	83	0,90	16,8	1,8	5,2	2,3			56	68
132S-8/4	2,3	6,8	5,4	715	74	0,66	30,7	1,7	4,2	2,6	0,0325	97	53	66
	3,6	7,3	5,8	1435	80,5	0,89	24	1,8	5,3	2,5			62	75
132M-8/4	3	8,1	6,5	720	80	0,67	40	1,9	4,6	2,7	0,046	113	53	66
	5	9,5	7,6	1435	84,5	0,90	33,3	1,9	5,8	2,6			62	75
160M ₁ -8/4	4,7	11,5	9,2	720	81	0,73	62	1,7	4,7	2,5	0,081	157	54	67
	5,5	12,1	9,7	1445	76,5	0,86	36,3	2,1	5,7	3			66	79
160M ₂ -8/4	5,5	12,1	9,7	715	83	0,79	73	1,7	4,6	2,2	0,108	170	54	67
	7,5	14,8	11,9	1440	81	0,90	50	2	6,1	2,8			66	79
160L-8/4	7	16,3	13	720	84	0,74	93	2	5,5	2,7	0,145	190	54	67
	11	22	17,5	1445	81,5	0,89	73	2	6,6	3			66	79
180L-8/4	11	25	19,8	725	86,5	0,74	145	2,2	6	2,8	0,243	215	53	66
	18	32	25,5	1460	88,5	0,92	118	2,1	6,9	3,2			63	76
200L-8/4	17	39,5	31,5	730	88,5	0,70	222	2,2	6,4	3,5	0,438	280	53	67
	27	47	37,5	1470	91	0,91	175	2,2	7,1	3,8			63	77
225S-8/4	22	47,5	38	735	89,5	0,75	286	2,3	6,4	3,3	0,625	372	56	70
	32	56	45	1475	90,5	0,91	207	2,1	7,2	3,5			67	81
225M-8/4	26	53	43	730	90	0,78	340	2,4	6,5	3,4	0,75	404	56	70
	38	65	52	1470	91	0,93	247	2,5	7,2	3,6			67	81
250M-8/4	32	64	51	735	90,5	0,80	416	1,9	6,4	2,9	1,28	570	55	69
	47	79	63	1480	92	0,93	303	2	7,7	3,3			68	82
280S-8/4	42	85	68	735	91,5	0,78	546	2,1	6,4	2,5	2	740	58	72
	60	101	81	1475	92,5	0,93	388	2,1	7,2	3,1			70	84
280M-8/4	50	98	78	735	92	0,80	650	2,1	6,5	2,4	2,4	810	58	72
	72	120	96	1475	93	0,93	466	2	7,2	3			70	84
315S-8/4	60	114	91	740	92,5	0,82	774	2,6	6,5	2,5	4,4	996	67	82
	90	150	120	1480	93	0,93	581	2,5	7	2,7			79	94
315M-8/4	75	143	114	740	92,5	0,82	968	2,6	6,3	2,5	5,4	1096	67	82
	110	184	147	1480	93	0,93	710	2,5	6,8	2,7			79	94
315L ₁ -8/4	90	170	136	740	93	0,82	1161	2,7	6,6	2,6	6,6	1221	67	82
	132	220	175	1480	93,5	0,93	852	2,5	7,1	3			79	94
315L ₂ -8/4	115	215	173	740	92,5	0,83	1484	2,7	6,6	2,6	8	1320	67	82
	160	265	215	1480	93	0,93	1032	2,6	7,1	3			79	94
355M-8/4	120	225	180	745	94	0,82	1538	1,3	6,6	2,4	8,9	1750	69	85
	175	320	255	1485	94,5	0,93	1125	1,5	7,3	2,5			76	92
355L ₁ -8/4	140	265	215	745	95	0,80	1795	1,4	6,9	2,5	10,9	1950	69	85
	215	345	275	1490	95,3	0,95	1378	1,6	7,6	2,3			76	92
355L ₂ -8/4	165	315	250	745	95	0,80	2115	1,3	6,8	2,4	12,6	2200	69	85
	250	400	320	1490	95,5	0,94	1602	1,5	7,6	2,4			76	92

Note

1) Version B3 with terminal box

The figures are also valid for series BD...

Mains Operation 50 Hz Pole-Changing Motors

80

Fan application temperature class T4

40 °C ambient temperature, winding temperature rise F

Frame-size CD...	2p = 4/2 1500/3000 rpm Output P ₂ [kW]		Frame size CD...	2p = 6/4 1000/1500 rpm Output P ₂ [kW]		Frame size CD...	2p = 8/4 750/1500 rpm Output P ₂ [kW]	
80K	0,17	0,65	-	-	-	-	-	-
80L	0,25	0,85	-	-	-	-	-	-
90L ₁	0,37	1,4	90L ₁	0,3	1	90L ₁	0,13	0,6
90L ₂	0,5	1,9	90L ₂	0,4	1,3	90L ₂	0,18	0,8
100L	0,85	3,2	100L ₁	0,6	1,8	100L ₁	0,3	1,3
			100L ₂	0,75	2,4	100L ₂	0,33	1,6
112M	1,2	4,4	112M	0,9	3	112M	0,5	2,5
132S	1,7	6	132S	1,3	4,3	132S	0,75	3,6
132M	2,3	9	132M	1,8	5,5	132M	1	5
160M	3,1	11	160M	3	9	160M ₁	1,6	5,5
160L	4,3	16	160L	3,5	12	160M ₂	1,8	7,5
						160L	2,3	11
180M	5,5	20	-	-	-	-	-	-
180L	6,3	25	180L	6,5	19	180L	3,7	18
200L	8,7	31	200L	9,5	26	200L	5,7	27
225S	11	38	225S	12	34	225S	7,3	32
225M	13	46	225M	14,5	40	225M	8,7	38
250M	15	55	250M	18	52	250M	11	47
280S	21	75	280S	25	70	280S	14	60
280M	24	87	280M	30	82	280M	17	72
315S	28	100	315S	32	95	315S	20	90
315M	33	125	315M	37	115	315M	25	110
315L ₁	40	150	315L ₁	47	135	315L ₁	30	132
315L ₂	48	175	315L ₂	55	160	315L ₂	38	160
355S	53	200	355S	60	185	-	-	-
355M ₁	60	220	355M	70	200	355M	40	175
355M ₂	67	250	355L	80	230	355L ₁	47	215
355L	73	280	-	-	-	355L ₂	55	250

The figures are also valid for series BD...

Mains Operation 60 Hz Pole-Changing Motors

Standard version and fan application
temperature class T4

81

40 °C ambient temperature, winding temperature rise F

Frame-size CD...	Standard version						Fan type					
	2p = 4/2 1800/3600 rpm Output P ₂ [kW]		2p = 6/4 1200/1800 rpm Output P ₂ [kW]		2p = 8/4 900/1800 rpm Output P ₂ [kW]		2p = 4/2 1800/3600 rpm Output P ₂ [kW]		2p = 6/4 1200/1800 rpm Output P ₂ [kW]		2p = 8/4 900/1800 rpm Output P ₂ [kW]	
80K	0,58	0,75	-	-	-	-	0,19	0,75	-	-	-	-
80L	0,81	1	-	-	-	-	0,27	1	-	-	-	-
90L ₁	1,3	1,6	0,52	0,75	0,46	0,7	0,43	1,6	0,35	1,15	0,15	0,7
90L ₂	1,7	2,2	0,7	1,05	0,64	0,93	0,57	2,2	0,46	1,5	0,21	0,93
100L	3	3,7	1,05	1,5	1,05	1,5	1	3,7	0,7	2,1	0,35	1,5
100L ₂	-	-	1,3	2	1,15	1,9	-	-	0,87	2,8	0,38	1,9
112M	4,3	5	1,7	2,8	1,8	2,9	1,4	5	1,05	3,5	0,6	2,9
132S	5,8	7	2,5	3,8	2,7	4,2	1,9	7	1,5	5	0,9	4,2
132M	8	10,5	3,5	5,2	3,5	5,8	2,7	10,5	2,1	6,4	1,15	5,8
160M ₁	-	-	-	-	5,4	6,4	-	-	-	-	1,8	6,4
160M ₂	11	12,7	5,2	12,7	6,4	8,7	3,7	12,7	3,5	10,5	2,1	8,7
160L	15	18,5	7,5	11	8,1	12,7	5	18,5	4,1	14	2,7	12,7
180M	19	23	-	-	-	-	6,3	23	-	-	-	-
180L	22	29	12,7	18,5	12,7	21	7,3	29	7,5	22	4,2	21
200L	30	36	18,5	28	20	31	10	36	11	30	6,7	31
225S	37	44	24	36	25	37	12	44	14	39	8,3	37
225M	44	53	29	43	30	44	15	53	17	46	10	44
250M	53	64	37	54	37	54	18	64	21	60	12	54
280S	73	87	52	76	49	69	24	87	29	81	16	69
280M	85	100	63	93	58	83	28	100	35	95	19	83
315S	94	110	70	98	69	104	31	110	37	110	23	104
315M	110	138	81	110	87	121	37	138	43	127	29	121
315L ₁	132	165	98	132	104	145	44	165	54	149	35	145
315L ₂	160	193	127	154	127	176	53	193	64	176	42	176
355S	176	220	121	176	-	-	59	220	-	-	-	-
355M ₁	198	240	-	-	-	-	66	240	-	-	-	-
355M ₂	220	275	143	198	123	193	73	275	69	205	44	193
355L ₁	240	310	165	230	154	235	80	310	81	220	51	235
355L ₂	-	-	-	-	182	275	-	-	93	255	61	275

The figures are also valid for series BD...

V

Mains Operation 50 Hz Motors with Integral Brake

82

Temperature class T4, 2p = 2, 4, 6, 8

Frame size	Output P ₂ [kW]	Rated current at		Speed n [rpm]	Efficiency η [%]	Power faktor cos φ	Starting moment M _s /M _N	Starting current I _s /I _N	Motor torque M [Nm]	Braking torque ¹⁾ M _B [Nm]	Mass inertia moment J [kgm ²]	Weight ²⁾ m [kg]	Permissible operation per hour in operating mode S4 15, 20, 40 or 60% ED			
		400V I [A]	500V I [A]										FL = 1,5 [S/h]	FL = 2 [S/h]	FL = 3 [S/h]	FL = 4 [S/h]
ns = 3000 rpm, 2p = 2																
80K-2	0,75	1,84	1,47	2790	70	0,84	2,7	4,8	2,57	10	0,000925	26	1110	935	710	570
80L-2	1,1	2,5	2	2820	75	0,85	2,8	5,5	3,7	10	0,00118	27	580	495	435	320
90L ₁ -2	1,5	3,25	2,6	2840	78	0,86	2,7	5,5	5	20	0,00193	38	130	115	90	80
90L ₂ -2	2,2	4,55	3,65	2850	81	0,86	2,7	5,6	7,4	20	0,00240	42	184	165	135	115
100L-2	3	6,1	4,85	2850	82	0,87	2,7	6,8	10,1	46	0,00365	51	71	65	54	47
112M-2	4	7,8	6,2	2880	84	0,88	2,3	6,5	13,3	46	0,00638	64	140	120	95	75
132S ₁ -2	5,5	11	8,8	2890	84	0,86	2,5	6	18,2	86	0,013	113	53	46	37	30
132S ₂ -2	7,5	14,8	11,8	2910	85	0,86	2,7	6,8	24,7	86	0,0159	118	70	60	45	40
ns = 1500 rpm, 2p = 4																
80K-4	0,55	1,38	1,1	1380	72	0,8	2	3,8	3,8	10	0,0013	26	1340	1185	960	800
80L-4	0,75	1,85	1,48	1400	74	0,79	2,1	4,2	5,2	10	0,00168	27	1340	1170	930	640
90L ₁ -4	1,1	2,5	2	1400	75	0,84	2,1	4,8	7,5	20	0,003	38	230	205	170	145
90L ₂ -4	1,5	3,3	2,65	1405	78	0,84	2,3	5	10,3	20	0,00525	42	270	245	200	170
100L ₁ -4	2,2	5	4	1420	79	0,8	2,4	5,4	14,8	46	0,00688	51	235	215	185	165
100L ₂ -4	3	6,6	5,3	1415	79,5	0,82	2,3	5,5	20,1	46	0,007	54	110	105	90	80
112M-4	4	8,2	6,5	1435	84	0,84	2,7	6,8	26,5	46	0,0133	69	220	210	180	160
132S-4	5,5	10,9	8,7	1435	85	0,86	2,5	6,2	36,5	86	0,0263	118	100	95	75	65
132M-4	7,5	14,5	11,6	1440	87	0,86	2,7	6,5	50	86	0,0348	128	100	90	75	65
ns = 1000 rpm, 2p = 6																
80K-6	0,37	1,12	0,9	925	67	0,71	2,5	4,1	3,8	10	0,0024	26	1120	950	725	590
80L-6	0,55	1,6	1,28	925	69	0,72	2,4	4	5,7	10	0,003	27	1145	980	765	620
90L ₁ -6	0,75	2,2	1,75	910	66	0,75	1,8	3,4	7,8	20	0,00445	38	675	605	500	425
90L ₂ -6	1,1	3,1	2,5	920	70	0,73	2	3,7	11,4	20	0,00573	42	125	115	100	85
100L-6	1,5	3,8	3,05	945	76	0,75	2,5	4,9	15,2	46	0,0113	54	240	215	175	145
112M-6	2,2	5,47	4,3	950	80	0,74	2,7	5,6	22,1	46	0,0198	69	595	530	425	355
132S-6	3	6,7	5,4	965	83	0,78	2,7	6,3	29,8	86	0,0347	118	390	350	290	250
132M ₁ -6	4	8,8	7	960	83,5	0,79	2,6	6	40	86	0,0415	124	215	195	160	140
132M ₂ -6	5,5	11,5	9,2	960	84,5	0,82	2,6	6,4	55	86	0,0498	133	125	110	95	80
ns = 750 rpm, 2p = 8																
80K-8	0,18	0,66	0,52	690	61	0,65	2,2	3,2	2,5	10	0,0023	26	1125	940	710	580
80L-8	0,25	0,91	0,73	690	62	0,64	2,2	3,2	3,5	10	0,0029	27	1125	940	710	580
90L ₁ -8	0,37	1,32	1,06	690	64	0,63	1,8	3	5,1	20	0,0039	38	1285	1090	920	780
90L ₂ -8	0,55	1,89	1,51	690	64,5	0,65	1,8	3,1	7,6	20	0,0052	42	1160	980	830	690
100L ₁ -8	0,75	2,3	1,85	710	70	0,67	2,4	4	10,2	46	0,0094	51	970	820	690	570
100L ₂ -8	1,1	3,1	2,5	695	70	0,73	2	3,8	15,1	46	0,0109	54	880	750	630	520
112M-8	1,5	4,2	3,35	710	77	0,67	2,2	4,6	20,5	46	0,0198	69	680	560	480	406
132S-8	2,2	5	4	695	80	0,79	2	4,1	30	86	0,0331	113	650	550	460	380
132M-8	3	7	5,6	705	80,5	0,77	2,4	4,6	41	86	0,0401	122	630	520	450	360

Note

1) Tolerance -20 %/+40 % at 1 m/s friction speed

2) Version B3 with terminal box

Frame size	Output P ₂ [kW]	Rated current at		Speed n [rpm]	Efficiency η [%]	Power faktor cos φ	Starting moment M _A /M _N	Starting current I _A /I _N	Motor torque M [Nm]	Braking torque ¹⁾ M _B [Nm]	Mass inertia ²⁾ J [kgm ²]	Weight m [kg]	Permissible operation per hour in operating mode S4 15, 20, 40 or 60% ED			
		400V I [A]	500V I [A]										FL = 1,5 [S/h]	FL = 2 [S/h]	FL = 3 [S/h]	FL = 4 [S/h]
ns = 750/1500 rpm, 2p = 8/4																
90L ₁ -8/4	0,4	1,54	1,23	690	57	0,66	1,4	2,8	5,7	20	0,0049	38	on request			
	0,6	1,44	1,15	1390	69	0,87	1,4	4,2	4							
90L ₂ -8/4	0,55	2,14	1,71	690	58	0,64	1,6	3	7,7	20	0,0069	42				
	0,8	1,9	1,52	1410	70	0,87	1,8	4,6	5,4							
100L ₁ -8/4	0,9	3	2,4	690	61	0,71	1,8	3,2	12,5	46	0,0098	51	on request			
	1,3	3	2,45	1400	69,5	0,89	1,5	4,2	8,9							
100L ₂ -8/4	1	3,2	2,55	700	65	0,7	1,8	3,7	13,6	46	0,0138	54				
	1,6	3,6	2,9	1400	71	0,9	1,6	4,5	10,9							
112M-8/4	1,5	4,4	3,5	700	72	0,69	2	4,4	30,5	46	0,0218	69	on request			
	2,5	5,3	4,25	1390	74,5	0,91	1,9	5	17,1							
132S-8/4	2,3	6,8	5,4	720	75	0,65	1,8	4,4	30,5	86	0,0353	127	on request			
	3,6	7,2	5,8	1440	81	0,89	1,8	5,4	23,8							
132M-8/4	3	8,5	6,7	720	78	0,66	2	4,6	40	86	0,0498	138				
	5	9,7	7,8	1440	82,5	0,9	1,9	5,8	33							
ns = 750/3000 rpm, 2p = 8/2																
80K-8/2	0,1	0,51	0,41	660	43	0,65	1,3	2,5	1,4	10	0,0015	26	on request			
	0,4	1,14	0,91	2870	60	0,84	1,5	2,5	1,3							
80L-8/2	0,14	0,72	0,58	660	43	0,65	1,3	2,5	2	10	0,0019	27				
	0,56	1,6	1,26	2870	60,3	0,85	1,5	2,5	1,9							
90L ₁ -8/2	0,2	0,9	0,73	710	53	0,6	1,5	3	2,7	20	0,0035	38	on request			
	0,8	1,95	1,56	2885	65	0,9	1,4	6	2,6							
90L ₂ -8/2	0,3	1,3	1,04	710	54	0,62	1,6	3	4	20	0,0058	42				
	1,1	2,5	2	2885	69,3	0,91	1,5	6,2	3,6							
100L ₁ -8/2	0,33	1,45	1,14	715	54	0,62	1,6	3	4,4	46	0,0069	51	on request			
	1,3	2,9	2,3	2885	70	0,92	1,4	6	4,3							
100L ₂ -8/2	0,4	1,75	1,38	715	54	0,62	1,6	3	5,3	46	0,007	54				
	1,5	3,35	2,65	2885	70,8	0,92	1,5	6	5							
112M-8/2	0,55	2,1	1,67	715	59,3	0,64	1,5	3,5	7,3	46	0,011	69	on request			
	2,2	4,9	3,95	2920	71	0,9	2	6,9	7,2							
132S-8/2	0,8	2,85	2,3	720	63,3	0,64	1,7	3,5	10,6	86	0,0286	127	on request			
	3,2	6,6	5,2	2935	76,6	0,92	2,3	6,9	10,4							
132M-8/2	1,1	3,7	2,95	720	65,8	0,66	1,8	3	14,6	86	0,037	138				
	4,2	8,3	6,6	2935	78,9	0,93	2,6	7	13,7							

Note

- 1) Tolerance -20%/+40 % at 1 m/s friction speed
- 2) Version B3 with terminal box



Mains Operation 50 Hz Motors with External Brake

84

Temperature class T4, 2p = 2, 4

Frame size	Output P ₂ [kW]	Rated current at		Speed n [rpm]	Efficiency η [%]	Power faktor cos φ	Motor torque M [Nm]	Starting moment M _A /M _N	Starting current I _A /I _N	Braking torque ¹⁾ M _B [Nm]	Brake type	Mass inertia moment J [kgm ²]	Weight ²⁾ m [kg]	Permissible operation per hour in operating mode S4			
		400V I [A]	500V I [A]											FL = 1,5 [S/h]	FL = 2 [S/h]	FL = 3 [S/h]	FL = 4 [S/h]
ns = 3000 rpm, 2p = 2																	
80K-2	0,75	1,74	1,39	2790	74	0,84	2,57	2,7	4,8	10	10	0,00083	39	on request			
80L-2	1,1	2,4	1,92	2820	78	0,85	3,73	2,8	5,5	10	10	0,00105	40				
90L ₁ -2	1,5	3,15	2,55	2840	78,5	0,87	5	2,7	5,5	20	11	0,00155	46				
90L ₂ -2	2,2	4,4	3,5	2850	83	0,87	7,4	2,7	5,6	20	11	0,00205	50				
100L-2	3	5,9	4,7	2850	85	0,87	10,1	2,7	6,8	50	13	0,00505	74				
112M-2	4	7,7	6,1	2880	85,5	0,88	13,3	2,3	6,5	50	13	0,00725	82				
132S ₁ -2	5,5	10,4	8,3	2880	87	0,88	18,2	2,5	6,4	50	13	0,01105	124				
132S ₂ -2	7,5	13,8	11,1	2910	88	0,89	24,6	2,7	6,8	100	16	0,01465	129				
160M ₁ -2	11	20	16	2925	89	0,89	36	2,8	6,6	150	19	0,0445	192				
160M ₂ -2	15	26,5	21	2920	89,5	0,92	49	2,8	6,8	150	19	0,0555	202				
160L-2	18,5	32	25,5	2925	90,5	0,92	60	2,6	6,8	150	19	0,0645	217				
180M-2	22	37,5	30	2925	91,5	0,92	72	2,5	6,9	150	19	0,0875	225				
200L ₁ -2	30	52	41,5	2955	92,5	0,90	97	2,6	7,2	270	24	0,1425	284				
200L ₂ -2	37	63	50	2955	93,3	0,91	120	2,7	7,2	270	24	0,1725	307				
ns = 1500 rpm, 2p = 4																	
80K-4	0,55	1,36	1,09	1380	73	0,80	3,8	2	3,8	10	10	0,00117	39	1340	1010	670	500
80L-4	0,75	1,81	1,45	1400	75,5	0,79	5,1	2,1	4,5	10	10	0,00155	40	1340	1010	670	500
90L ₁ -4	1,1	2,5	1,99	1400	77	0,83	7,5	2,1	4,8	20	11	0,0024	46	230	170	110	90
90L ₂ -4	1,5	3,35	2,65	1405	79	0,82	10,2	2,3	5	20	11	0,0032	51	270	200	135	100
100L ₁ -4	2,2	4,8	3,8	1420	81	0,82	14,8	2,4	5,4	50	13	0,0049	66	235	175	120	90
100L ₂ -4	3	6,3	5,1	1415	82,5	0,83	20,2	2,3	5,5	50	13	0,0078	83	110	80	55	45
112M-4	4	8,1	6,5	1435	85	0,84	26,6	2,7	6,8	50	13	0,013	97	220	165	110	85
132S-4	5,5	10,7	8,6	1440	87	0,85	36,5	2,5	6,2	50	13	0,025	142	150	110	75	55
132M-4	7,5	14,3	11,4	1440	88,2	0,86	50	2,7	6,5	100	16	0,033	152	140	105	70	50
160M-4	11	21	16,7	1460	89,5	0,85	72	2,5	6,6	150	19	0,06	210	95	70	50	35
160L-4	15	28	22,5	1455	90	0,86	98	2,8	6,5	150	19	0,092	251	60	45	30	25
180M-4	18,5	34,5	27,5	1460	91	0,85	121	2,9	6,6	150	19	0,143	243	70	50	35	25
180L-4	22	41	32,5	1460	91,5	0,85	144	3	6,9	270	24	0,168	277	60	45	30	20
200L-4	30	53	42,5	1460	92,5	0,88	196	2,6	6,8	270	24	0,26	344	40	50	20	15

The figures are also valid for series BD...

Temperature class T4, 2p = 6, 8

Frame size	Output P ₂ [kW]	Rated current at		Speed n [rpm]	Efficiency η [%]	Power faktor cos φ	Motor torque M [Nm]	Starting moment M _A /M _N	Starting current I _A /I _N	Braking torque ¹⁾ M _B [Nm]	Brake type	Mass inertia moment J [kgm ²]	Weight ²⁾ m [kg]	Permissible operation per hour in operating mode S4			
		400V I [A]	500V I [A]											FL = 1,5 [S/h]	FL = 2 [S/h]	FL = 3 [S/h]	FL = 4 [S/h]
ns = 1000 rpm, 2p = 6																	
80K-6	0,37	1,12	0,90	925	67	0,71	3,8	2,5	4,1	10	10	0,0012	39	1260	945	630	470
80L-6	0,55	1,6	1,28	925	69	0,72	5,7	2,4	4	10	10	0,0028	40	540	400	270	200
90L ₁ -6	0,75	2,15	1,72	910	67	0,75	7,9	1,8	3,4	20	11	0,0036	46	420	310	210	150
90L ₂ -6	1,1	3,05	2,45	920	71	0,73	11,4	2	3,7	20	11	0,0049	51	560	420	280	210
100L-6	1,5	3,75	3	945	77	0,75	15,2	2,4	5	50	13	0,0098	68	44	330	220	165
112M-6	2,2	5,2	4,2	950	81	0,75	22,1	2,7	5,6	50	13	0,02	97	240	180	120	90
132S-6	3	6,6	5,3	965	84	0,78	29,7	2,7	6,3	50	13	0,034	142	170	130	85	54
132M ₁ -6	4	8,6	6,9	960	85	0,79	40	2,6	6	50	13	0,04	164	240	180	120	90
132M ₂ -6	5,5	11,4	9,1	960	86	0,81	55	2,6	6,4	100	16	0,046	152	220	165	110	80
160M-6	7,5	14,7	11,7	960	86,8	0,85	75	2,5	6,8	150	19	0,09	212	290	220	145	110
160L-6	11	21	16,9	965	87,5	0,86	109	2,5	6,7	150	19	0,13	257	160	120	80	60
180L-6	15	28,5	23	965	90	0,84	148	2,4	6,9	270	24	0,2	285	130	100	65	50
200L ₁ -6	18,5	35	28	975	90,5	0,84	181	1,9	6,2	270	24	0,29	340	90	65	45	35
200L ₂ -6	22	41	33	970	91	0,85	217	2,2	6,8	270	24	0,32	350	80	60	40	30
ns = 750 rpm, 2p = 8																	
80K-8	0,18	0,66	0,52	690	61	0,65	2,5	2,2	3,2	10	10	0,0021	39	960	720	480	360
80L-8	0,25	0,91	0,73	690	62	0,64	3,5	2,2	3,2	10	10	0,0028	40	720	540	360	270
90L ₁ -8	0,37	1,3	1,04	690	63	0,65	5,1	1,8	3	20	11	0,0036	46	560	420	280	210
90L ₂ -8	0,55	1,85	1,48	690	67	0,64	7,6	1,8	3,1	20	11	0,0049	51	530	400	265	200
100L ₁ -8	0,75	2,3	1,85	710	71	0,66	10,1	2,4	4	50	13	0,0083	65	500	375	250	190
100L ₂ -8	1,1	3,15	2,5	695	69	0,73	15,1	2	3,8	50	13	0,0098	68	700	530	350	260
112M-8	1,5	4,15	3,3	710	78	0,67	20,2	2,2	4,6	50	13	0,019	97	620	465	310	230
132S-8	2,2	5	4	695	80	0,79	30	2	4,1	50	13	0,031	139	230	170	115	90
132M-8	3	6,9	5,6	705	81	0,77	41	2,4	4,6	50	13	0,038	152	240	180	120	90
160M ₁ -8	4	8,7	7	715	85	0,78	53	1,8	4,6	150	19	0,073	201	150	110	75	55
160M ₂ -8	5,5	12	9,6	720	86	0,77	73	2,1	5,4	150	19	0,107	212	145	110	70	55
160L-8	7,5	16,3	13	720	86,5	0,77	99	2,2	5,6	150	19	0,149	257	145	110	70	55
180L-8	11	22,5	18,1	725	89	0,79	145	2,4	6,4	270	24	0,23	285	200	150	100	75
200L-8	15	30	24	730	89,5	0,80	196	2,4	6,9	270	24	0,41	350	100	75	50	35

Note

1) Specification for brakes up to 270 Nm: II 2G EEx de IIC T5 or optional II 2D IP67 T100°C; DMT 02 ATEX E 122

2) Version B3 with terminal box

400 Nm brake on request.

Coil Data for Brakes

86

Integral brakes

Motor Frame size	Brake Frame size	Voltage U = [V]	Current I = [A]	Resistance R _{min} [Ω]	Voltage U ~ [V]	Current I ~ [A]
80	M8	24	1,09	22	-	-
		103	0,29	369	230	0,46
		130	0,23	567	290	0,36
		176	0,19	910	400	0,3
90	M16	24	1,5	16	-	-
		103	0,36	290	230	0,57
		130	0,35	376	290	0,55
		176	0,26	684	400	0,41
100 and 112	M32	24	1,85	13	-	-
		103	0,42	244	230	0,66
		130	0,35	376	290	0,55
		176	0,31	575	400	0,49
132	M60	24	2,93	8,58	-	-
		130	0,56	232	290	0,88
		176	0,49	360	400	0,77

External brakes

Brake Frame size	Torque M [Nm]	Voltage U = [V]	Current I = [A]	Resistance R _{min} [Ω]	Voltage U ~ [V]	Current I ~ [A]
10/11	10 or 20	24	2,1	11,6	-	-
		98	0,55	177	110	0,61
		205	0,27	770	230	0,3
		215	0,225	954	240	0,25
		258	0,21	1197	270	0,23
		356	0,14	2571	400	0,16
13/16	50 or 100	24	2,93	8,2	-	-
		98	0,8	122,4	110	0,89
		205	0,39	536	230	0,44
		215	0,346	621	240	0,38
		258	0,31	838	270	0,34
		356	0,2	1685	400	0,24
19/24	150 or 270	24	3,08	7,8	-	-
		98	0,85	116	110	0,94
		205	0,4	516	230	0,45
		215	0,4	538	240	0,44
		356	0,25	1438	400	0,28

Three-phase AC Asynchronous Motors with Integrated Frequency Inverter

Compact Drive

Temperature class T4, 2p = 2, 4

87

Operation on the Torque character	Mains 50 Hz	Inverter										Inverter Decreasing 50-100 Hz	
		drop by square val.		Constant		Constant		Constant		Constant			
Frequency	50 Hz	5-50 Hz		20-50 Hz		10-50 Hz		5-50 Hz		2-50 Hz		50-100 Hz	
Control range	-	1:10		1:2,5		1:5		1:10		1:25		50-100 Hz	
Speed range	-	300-3000 rpm		1200-3000 rpm		600-3000 rpm		300-3000 rpm		120-3000 rpm		3000-6000 rpm	
Output/torque	P ₂ [kW]	P ₀ [kW] 50 Hz	M ₀ [Nm]	P ₀ [kW] 50 Hz	M ₀ [Nm]	P ₀ [kW] 50 Hz	M ₀ [Nm]	P ₀ [kW] 50 Hz	M ₀ [Nm]	P ₀ [kW] 50 Hz	M ₀ [Nm]	P ₀ [kW] 100 Hz	M ₀ [Nm]
80K - 2 I	0,75	0,75	2,6	0,7	2,4	0,6	2	0,5	1,7	0,47	1,6	0,75	1,2
80L - 2 I	1,1	1,1	3,7	1	3,4	0,9	3	0,75	2,5	0,7	2,35	1,1	1,75
90L ₁ - 2 I	1,5	1,5	5	1,4	4,7	1,2	4	1	3,3	0,94	3,3	1,35	2,2
90L ₂ - 2 I	2,2	2,2	7,4	2	6,7	1,7	5,7	1,4	4,7	1,3	4,4	2	3,2
100L - 2 I	3	3	10	2,7	8,9	2,2	7,2	1,8	5,9	1,7	5,5	2,7	4,5
112M - 2 I	4	4	13	3,7	12	3,2	11	2,5	8,2	2,35	7,7	4	6,4
132S ₁ - 2 I	5,5	5,5	18	5	16	4,5	15	3,7	12	3,3	10,8	5,2	8,3
132S ₂ - 2 I	7,5	7,5	25	7	23	6	20	5	16	4,5	14,4	6,5	10,3
160M ₁ - 2 I	11	11	36	10	32	9	29	7,5	24	6,6	21,5	8,4	13,4

Operation on the Torque character	Mains 50 Hz	Inverter										Inverter Decreasing 50-100 Hz	
		drop by square val.		Constant		Constant		Constant		Constant			
Frequency	50 Hz	5-50 Hz		20-50 Hz		10-50 Hz		5-50 Hz		2-50 Hz		50-100 Hz	
Control range	-	1:10		1:2,5		1:5		1:10		1:25		50-100 Hz	
Speed range	-	150-1500 rpm		600-1500 rpm		300-1500 rpm		150-1500 rpm		60-1500 rpm		1500-3000 rpm	
Output/torque	P ₂ [kW]	P ₀ [kW] 50 Hz	M ₀ [Nm]	P ₀ [kW] 50 Hz	M ₀ [Nm]	P ₀ [kW] 50 Hz	M ₀ [Nm]	P ₀ [kW] 50 Hz	M ₀ [Nm]	P ₀ [kW] 50 Hz	M ₀ [Nm]	P ₀ [kW] 100 Hz	M ₀ [Nm]
80K - 4 I	0,55	0,55	3,8	0,52	3,5	0,45	3	0,33	2,2	0,31	2,05	0,49	1,5
80L - 4 I	0,75	0,75	5,2	0,7	4,8	0,6	4	0,5	3,3	0,47	3,1	0,69	2,2
90L ₁ - 4 I	1,1	1,1	7,5	1	6,7	0,9	6	0,75	5	0,7	4,7	1	3,1
90L ₂ - 4 I	1,5	1,5	10	1,4	9,5	1,2	8	1	6,7	0,94	6,3	1,35	4,3
100L ₁ - 4 I	2,2	2,2	15	2	13	1,7	11	1,4	9,3	1,3	8,7	2	6,4
100L ₂ - 4 I	3	3	20	2,8	19	2,2	15	1,8	12	1,7	11,3	2,7	8,6
112M - 4 I	4	4	27	3,6	24	3	20	2,5	16	2,35	15	4	12,7
132S - 4 I	5,5	5,5	37	5	33	4,4	29	3,7	24	3,3	21,6	5,2	16,5
132M - 4 I	7,5	7,5	50	7	46	6	39	5	33	4,5	29,7	6,5	20,7
160M - 4 I	11	11	72	10	65	9	58	7,5	49	6,6	44	8,4	26,7

V

Mains Operation 50 Hz Noise Class 4, Water-Cooled Motors



Temperature class T4, 2p = 2, 4

Frame size	Output	Current at	Rated speed	Efficiency	Power factor	Starting moment	Starting current	Weight ²⁾	Coolant volume	Noise values	
CD...W	P ₂ [kW]	400V I [A]	n [rpm]	η [%]	cos φ	M _A /M _N	I _A /I _N	m [kg]	[l/min] 30 °C	L _p [dB(A)]	L _w [dB(A)]
ns = 3000 rpm, 2p = 2											
160M1-2	15	28,5	2915	87,5	0,87	2,5	6,5	125	5	51	64
160M2-2	18,5	33,5	2915	89	0,89	2,5	6,5	140	5	51	64
160L-2	22	39,5	2915	89,5	0,9	2,7	6,8	150	5	51	64
180M-2	30	54	2915	90	0,89	2,6	6,9	170	5	51	64
200L ₁ -2	37	69	2950	91,5	0,85	3	7,2	270	5	52	66
200L ₂ -2	45	79	2950	92	0,85	3	7,2	290	5	52	66
225M-2	55	101	2965	92,5	0,85	2,8	7,1	455	5	54	68
250M-2	75	139	2970	92,5	0,84	2,7	6,9	564	5	57	71
280S-2	90	155	2970	93	0,9	2	6,5	665	7	59	73
280M-2	110	192	2970	93	0,89	2,1	6,8	776	6	59	73
315S-2	132	225	2975	94,5	0,89	1,9	6,3	1010	10	60	75
315M-2	160	270	2975	95,5	0,89	1,8	6,7	1100	10	60	75
315L ₁ -2	200	340	2975	95,5	0,89	2	6,9	1200	12	60	75
315L ₂ -2	250	420 ¹⁾	2980	96	0,9	1,7	6,9	1300	12	60	75
355M-2	315	510 ¹⁾	2985	96,5	0,92	1,5	6,8	1850	13	60	76
355L ₁ -2	355	575 ¹⁾	2985	96,5	0,92	1,5	6,8	2100	15	60	76
355L ₂ -2	400	650 ¹⁾	2985	96,8	0,92	1,5	6,8	2300	18	60	76
ns = 1500 rpm, 2p = 4											
160M-4	13,5	29	1450	86,5	0,78	2,6	6,1	130	5	51	64
160L-4	18,5	36	1450	89	0,84	2,5	6,2	150	5	51	64
180M-4	22	43,5	1460	90	0,81	3,1	6,7	170	5	51	64
180L-4	27	53	1455	90	0,81	3	6,5	190	5	51	64
200L-4	37	67	1460	91	0,87	2,7	6,8	295	5	51	65
225S-4	45	81	1465	92	0,87	2,6	6,3	441	5	52	66
225M-4	55	100	1470	92,5	0,86	2,6	6,5	480	5	52	66
250M-4	70	127	1475	92,5	0,86	2,9	7,1	590	6	56	70
280S-4	90	163	1480	93,5	0,85	2,7	6,7	745	6	58	72
280M-4	110	199	1480	94	0,85	2,9	6,9	850	7	58	72
315S-4	132	235	1485	95	0,86	2,2	6,6	1050	10	57	72
315M-4	160	290	1485	95,5	0,84	2,8	6,8	1115	10	57	72
315L ₁ -4	200	350	1485	95,5	0,86	2,5	6,8	1200	12	57	72
315L ₂ -4	250	435 ¹⁾	1490	96	0,86	2	6,9	1300	12	57	72
355M-4	315	525 ¹⁾	1490	96,5	0,9	1,5	6,8	2000	13	58	74
355L ₁ -4	355	590 ¹⁾	1490	96,5	0,9	1,5	6,8	2250	15	58	74
355L ₂ -4	400	665 ¹⁾	1490	96,7	0,9	1,5	6,8	2450	17	58	74

Note

- 1) Two parallel feeds are necessary in each case
- 2) Version B3 with terminal box

Mains Operation 50 Hz High-Voltage Motors

Temperature class T4, 2p = 2, 4, 6, 8

Frame size	Output	Rated current at 6000 V	Speed	Efficiency	Power factor	Torque	Starting moment	Starting current	Stalling torque	Mass inertia moment	Weight	Noise values with radial-flow fan	
CD...H	P ₂ [kW]	I [A]	n [rpm]	η [%]	cos φ	M [Nm]	M _A /M _N	I _A /I _N	M _K /M _N	J [kgm ²]	m [kg]	L _p [dB(A)]	L _w [dB(A)]
ns = 3000 rpm, 2p = 2													
355M-2	160	18,1	2981	94,5	0,9	513	1,1	6,5	2,5	2,6	1825	82	98
355L ₁ -2	200	22,5	2981	94,8	0,9	641	1,1	6,6	2,5	3,1	2008	82	98
355L ₂ -2	250	28	2982	95	0,91	801	1,1	6,6	2,6	3,4	2100	82	98
400M-2	280	31	2982	95,3	0,91	897	1	6,4	2,6	7,7	2389	82	98
400L-2	315	35	2982	95,5	0,91	1009	1	6,5	2,6	10,1	2800	82	98
450M ₁ -2	355	39,5	2985	95,8	0,9	1136	0,9	6,6	2,7	9,4	3268	85	101
450M ₂ -2	400	44,5	2987	96	0,9	1279	0,9	6,6	2,7	10,6	3437	85	101
450L ₁ -2	450	49,5	2987	96,2	0,91	1439	0,9	6,5	2,6	12,6	3699	85	101
450L ₂ -2	500	55	2988	96,4	0,91	1598	0,9	6,6	2,7	14,6	3962	85	101
450L ₃ -2	560	61	2988	96,5	0,91	1790	0,9	6,5	2,6	16,8	4262	85	101
ns = 1500 rpm, 2p = 4													
355M ₁ -4	160	19,3	1488	94,8	0,84	1027	1,2	6,6	2,4	4,2	1800	73	89
355M ₂ -4	220	26,5	1488	95,2	0,84	1412	1,2	6,6	2,4	5	1950	73	89
355L-4	280	33,5	1488	95,4	0,84	1797	1,2	6,6	2,4	5,9	2213	73	89
400M-4	315	37	1490	95,6	0,86	2019	1,1	6,6	2,5	12,9	3460	79	95
400L ₁ -4	355	41,5	1490	95,8	0,86	2275	1,1	6,5	2,4	14,5	3665	79	95
400L ₂ -4	400	46,5	1490	96	0,86	2564	1,1	6,6	2,5	16,4	3900	79	95
450M ₁ -4	450	53	1491	96	0,85	2882	1	6,5	2,5	18,5	3887	80	96
450M ₂ -4	500	59	1491	96,1	0,85	3203	1	6,6	2,5	20,7	4112	80	96
450L ₁ -4	560	66	1492	96,2	0,85	3584	1	6,7	2,6	23,3	4375	80	96
450L ₂ -4	630	73	1492	96,3	0,86	4033	0,9	6,5	2,4	26,2	4675	80	96
450L ₃ -4	710	82	1492	96,5	0,86	4545	1	6,5	2,5	29,5	5012	80	96
ns = 1000 rpm, 2p = 6													
355M-6	160	21	990	94,2	0,78	1543	1,2	6	2,2	5	1950	75	91
355L-6	200	26	990	94,3	0,79	1929	1,2	5,9	2,1	5,9	2179	75	91
400M-6	250	31	991	95,2	0,81	2409	1,2	6,4	2,3	12,9	3460	78	94
400L ₁ -6	280	35	991	95,4	0,81	2698	1,2	6,5	2,3	14,5	3665	78	94
400L ₂ -6	315	39	991	95,6	0,81	3036	1,2	6,5	2,3	16,4	3900	78	94
450M ₁ -6	355	42,5	991	95,6	0,84	3421	1	6,3	2,4	29,1	4112	78	94
450M ₂ -6	400	47,5	991	95,7	0,85	3855	1	6,3	2,4	32,7	4375	78	94
450L ₁ -6	450	53	991	95,7	0,86	4337	1	6,3	2,4	36,8	4675	78	94
450L ₂ -6	500	58	992	95,8	0,86	4814	1	6,4	2,4	41,5	5012	78	94
ns = 750 rpm, 2p = 8													
400M-8	160	21,5	742	94,2	0,76	2059	1,1	5,3	2	12,9	3460	74	90
400L ₁ -8	200	27	742	94,5	0,76	2574	1,1	5,5	2	14,5	3665	74	90
400L ₂ -8	240	32	742	94,6	0,76	3089	1,1	5,5	2	16,4	3900	74	90
450M ₁ -8	280	37	743	94,6	0,77	3599	1,1	5,8	2,3	29,1	4112	74	90
450M ₂ -8	315	41	743	94,7	0,78	4049	1	5,7	2,3	32,7	4375	74	90
450L ₁ -8	355	47	743	94,8	0,77	4563	1	5,9	2,4	36,8	4675	74	90
450L ₂ -8	400	52	744	94,9	0,78	5134	1	6	2,4	41,5	5012	74	90

Note
60 Hz on request.

Surface-Cooled Low-Voltage Motors, Self-Cooling with Radial-Flow Fan

90

Version IM B3, IM B6, IM B7, IM B8, IM V5¹⁾, IM V6

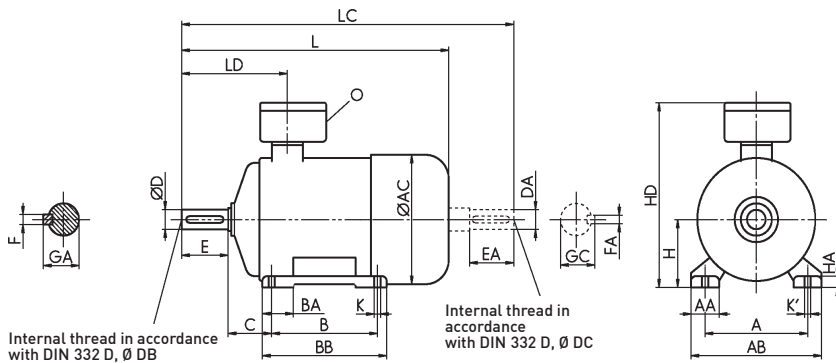

Frame size 63 in T4 without fan.
 Eye bolts from frame size 90.
 Dimension AC measured over screw heads.
 Dimension HD applies to Ex e box.
 Terminal box can be rotated 4 x 90°.
 Valid for series BD..., too

Note

1) For version IM V5 canopy required, see dimension LE page 93

Type CD...	A	AA	AB	AC	B	BA	BB	C	H _{-0,5}	HA	HD	K	K'
63K+L	100	20	120	134	80	25	100	40	63	6	227	7	10
71K+L	112	30	139	145	90	25	110	45	71	10	235	7	10
80K+L	125	35	160	163	100	35	130	50	80	12	260	9,5	12
90L	140	40	180	183	125	40	155	56	90	12	275	9,5	12
100L	160	45	200	201	140	45	175	63	100	15	305	12	15
112M	190	50	235	225	140	50	175	70	112	17	317	12	15
132S	216	60	266	265	140	60	187	89	132	20	411	12	15
132M	216	60	266	265	178	60	225	89	132	20	411	12	15
160M	254	65	310	318	210	100	300	108	160	25	477	15	20
160L	254	65	310	318	254	100	300	108	160	25	477	15	20
180M	279	75	350	353	241	100	340	121	180	25	545	15	20
180L	279	75	350	353	279	100	340	121	180	25	545	15	20
200L	318	80	390	393	305	90	365	133	200	30	581	20	26

Type CD...	A	AA	AB	AC	B	BA	BB	C	H	HA	HD	K	K'
225S	356	85	450	455	286	90	370	149	225 _{0,5}	35	634	20	26
225M	356	85	450	455	311	90	370	149	225 _{0,5}	35	634	20	26
250M	406	105	510	493	349	110	420	168	250 _{0,5}	40	721	26	35
280S	457	110	570	548	368	120	500	190	280 ₁	45	791	26	35
280M	457	110	570	548	419	120	500	190	280 ₁	45	791	26	35
315S	508	150	630	635	406	210	615	216	315 ₁	40	896	39	30
315M	508	150	630	635	457	210	615	216	315 ₁	40	896	39	30
315L ₁	508	150	630	635	508	210	615	216	315 ₁	40	896	39	30
315L ₂	508	150	630	635	508	210	615	216	315 ₁	40	896	39	30
315L ₃	508	150	630	635	508	210	615	216	315 ₁	40	896	39	30
355M	610	180	720	725	560	220	720	254	355 ₁	50	1084	30	39
355L ₁	610	180	720	725	630	220	720	254	355 ₁	50	1084	30	39
355L ₂	610	180	720	725	630	220	720	254	355 ₁	50	1084	30	39
355L ₃	610	180	720	725	630	220	720	254	355 ₁	30	1084	30	30
400S	686	130	800	810	560	150	870	280	400 ₁	34	1146	35	35
400M	686	130	800	810	630	150	870	280	400 ₁	34	1146	35	35
400L	686	130	800	810	710	150	870	280	400 ₁	34	1146	35	35
450S	760	150	900	910	630	180	1000	280	450 ₁	35	1264	35	35
450M	760	150	900	910	710	180	1000	280	450 ₁	35	1264	35	35
450L ₁	760	150	900	910	840	180	1000	280	450 ₁	35	1264	35	35
450L ₂	760	150	900	910	840	180	1000	280	450 ₁	35	1264	35	35

VII

Note

1) For Type 250 to 400-4, 6, 8 dimension DA, EA, GC, FA, DC the specifications for pole number 2 apply.

For Type 450 -6, 8 dimension DA, EA, GC, FA, DC the specifications for pole number 4 apply.

Type CD...	L No. poles				LC No. poles			LD	0	Shaft ends D, DA	E, EA	GA, GC	F, FA	DB, DC
	2	4	6	8	2	4	6, 8							
63K+L	239	239	239	239	273	273	273	104	2x M25x1,5	11k6	23	12,5	4	M4
71K+L	288	288	288	288	334	334	334	111	2x M25x1,5	14k6	30	16	5	M5
80K+L	313	313	313	313	387	387	387	116	2x M25x1,5	19k6	40	21,5	6	M6
90L	364	364	364	364	445	445	445	137	2x M25x1,5	24k6	50	27	8	M8
100L	415	415	415	415	510	510	510	149	2x M32x1,5	28k6	60	31	8	M10
112M	423	423	423	423	524	524	524	154	2x M32x1,5	28k6	60	31	8	M10
132S	529	529	529	529	645	645	645	226	2x M32x1,5	38k6	80	41	10	M12
132M	529	529	529	529	645	645	645	226	2x M32x1,5	38k6	80	41	10	M12
160M	708	676	676	676	863	831	831	261	2x M40x1,5	42k6	110	45	12	M16
160L	708	676	676	676	863	831	831	261	2x M40x1,5	42k6	110	45	12	M16
180M	726	726	-	-	909	909	-	369	2x M40x1,5	48k6	110	51,5	14	M16
180L	-	726	726	726	-	909	909	369	2x M40x1,5	48k6	110	51,5	14	M16
200L	789	789	789	789	983	909	909	390	2x M50x1,5	55m6	110	59	16	M20

Type CD...	L No. poles				LC No. poles			LD No. poles	0	Shaft ends D _{m6} DA _{m6} ¹⁾			E, EA ¹⁾	GA, GC ¹⁾			F, FA ¹⁾	DB, DC ¹⁾				
	2	4	6	8	2	4	6,8			2	4	6+8		2	4,6,8	2		4	6+8	2	4,6,8	2
225S	-	936	-	887	-	1175	1175	-	377	2x M50x1,5	-	60	60	-	140	-	64	64	-	18	-	M20
225M	906	936	887	887	1115	1175	1175	347	377	2x M50x1,5	55	60	60	110	140	59	64	64	16	18	M20	M20
250M	1001	1001	935	935	1251	1251	1185	482	482	2x M63x1,5	60	65	65	140	140	64	69	69	18	18	M20	M20
280S	1110	1110	1110	1110	1375	1375	1375	483	483	2x M63x1,5	65	75	75	140	140	69	79,5	79,5	18	20	M20	M20
280M	1110	1110	1110	1110	1375	1375	1375	483	483	2x M63x1,5	65	75	75	140	140	69	79,5	79,5	18	20	M20	M20
315S	1268	1298	1218	1218	1543	1573	1573	496	526	2x M63x1,5	65	80	80	140	170	69	85	85	18	22	M20	M20
315M	1268	1298	1218	1218	1543	1573	1573	496	526	2x M63x1,5	65	80	80	140	170	69	85	85	18	22	M20	M20
315L ₁	1268	1298	1218	1298	1543	1573	1573	496	526	2x M63x1,5	65	80	80	140	170	69	85	85	18	22	M20	M20
315L ₂	1468	1498	1218	1298	1743	1773	1573	496	526	2x M63x1,5	65	80	80	140	170	69	85	85	18	22	M20	M20
315L ₃	1468	1498	1418	1498	1743	1773	1773	496	526	2x M63x1,5	65	80	80	140	170	69	85	85	18	22	M20	M20
355M	-	-	1697	1697	-	-	1980	672	702	2x M80x2	75	90	90	140	170	79,5	95	95	20	25	M20	M24
355L ₁	1667	1697	1697	1697	1950	1980	1980	672	702	2x M80x2	75	90	90	140	170	79,5	95	95	20	25	M20	M24
355L ₂	1667	1697	1697	1697	1950	1980	1980	672	702	2x M80x2	75	90	90	140	170	79,5	95	95	20	25	M20	M24
355L ₃	1747	1777	-	-	2030	2060	-	672	702	2x M80x2	75	90	90	140	170	79,5	95	95	20	25	M20	M24
400S	-	1907	1907	1907	-	2190	2190	716	786	2x M95x2	75	100	100	140	210	79,5	106	106	20	28	M20	M24
400M	1837	1907	1907	1907	2120	2190	2190	716	786	2x M95x2	75	100	100	140	210	79,5	106	106	20	28	M20	M24
400L	1837	1907	1907	1907	2120	2190	2190	716	786	2x M95x2	75	100	100	140	210	79,5	106	106	20	28	M20	M24
450S	1850	1920	1920	1920	2140	2280	2280	755	825	2x M95x2	75	100	110	140	210	79,5	106	116	20	28	M20	M24
450M	1850	1920	1920	1920	2140	2280	2280	755	825	2x M95x2	75	100	110	140	210	79,5	106	116	20	28	M20	M24
450L ₁	1850	1920	1920	1920	2140	2280	2280	755	825	2x M95x2	75	100	110	140	210	79,5	106	116	20	28	M20	M24
450L ₂	-	2065	2065	2065	-	2425	2425	755	825	2x M95x2	75	100	110	140	210	79,5	106	116	20	28	M20	M24

Surface-Cooled Low-Voltage Motors, Self-Cooling with Radial-Flow Fan

92

Version IM B5, IM V1¹⁾, IM V3

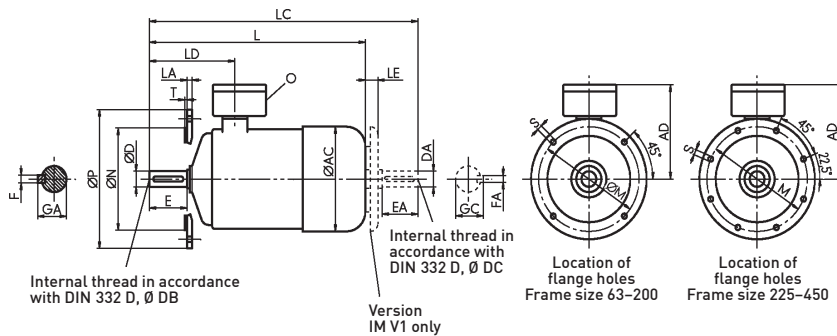

Frame size 63 in T4 without fan.
Mounting flange according to EN 50347 form FF. Eye bolts from frame size 90.
Dimension AC measured over screw heads.
Dimension AD applies to Ex e box.
Terminal box 4 x 90°.
Valid for series BD..., too
Frame size 400-450 in only Version V1 available.

Note

1) For version IM V1 canopy required, see dimension LE page 93; dimension LC includes LE

Type CD...	Mounting flange		N	P	S	T	AC	AD	L			
	LA	M							No. poles	2	4	6
63K+L	9	115	95j6	140	10	3	134	164	239	239	239	239
71K+L	9	130	110j6	160	10	3,5	145	164	288	288	288	288
80K+L	12	165	130j6	200	12	3,5	163	180	313	313	313	313
90L	12	165	130j6	200	12	3,5	183	185	364	364	364	445
100L	16	215	180j6	250	14,5	4	201	205	415	415	415	415
112M	16	215	180j6	250	14,5	4	225	205	423	423	423	423
132S+M	16	265	230j6	300	14,5	4	265	279	529	529	529	529
160M+L	20	300	250j6	350	18,5	5	318	317	708	676	676	676
180M	20	300	250j6	350	18,5	5	353	365	726	726	-	-
180L	20	300	250j6	350	18,5	5	353	365	-	726	726	726
200L	20	350	300h6	400	18,5	5	393	381	789	789	789	789

Type CD...	Mounting flange		N _{h6}	P	S	T	AC	AD	L			
	LA	M							No. poles	2	4	6
225S	22	400	350	450	18,5	5	455	409	-	936	-	887
225M	22	400	350	450	18,5	5	455	409	906	936	887	887
250M	18	500	450	550	18,5	5	493	471	1001	1001	935	935
280S	18	500	450	550	18,5	5	548	511	1110	1110	1110	1110
280M	18	500	450	550	18,5	5	548	511	1110	1110	1110	1110
315S	22	600	550	660	24	6	635	581	1268	1298	1218	1218
315M	22	600	550	660	24	6	635	581	1268	1298	1218	1218
315L ₁	22	600	550	660	24	6	635	581	1268	1298	1218	1298
315L ₂	22	600	550	660	24	6	635	581	1468	1498	1218	1298
315L ₃	22	600	550	660	24	6	635	581	1468	1498	1418	1498
355M	25	740	680	800	24	6	725	729	-	-	1697	1697
355L ₁	25	740	680	800	24	6	725	729	1667	1697	1697	1697
355L ₂	25	740	680	800	24	6	725	729	1667	1697	1697	1697
355L ₃	25	740	680	800	24	6	725	729	1747	1777	-	-
400S	28	940	880	1000	28	6	810	746	-	1907	1907	1907
400M	28	940	880	1000	28	6	810	746	1837	1907	1907	1907
400L	28	940	880	1000	28	6	810	746	1837	1907	1907	1907
450S	28	940	880	1000	28	6	910	814	1850	1920	1920	1920
450M	28	940	880	1000	28	6	910	814	1850	1920	1920	1920
450L ₁	28	940	880	1000	28	6	910	814	1850	1920	1920	1920
450L ₂	28	940	880	1000	28	6	910	814	-	2065	2065	2065

Note

1) For Type 250 to 400-4, 6, 8 dimension DA, EA, GC, FA, DC the specifications for pole number 2 apply.
For Type 450-6, 8 dimension DA, EA, GC, FA, DC the specifications for pole number 4 apply.

Type CD...	LC No. poles				LD	LE No. poles			O	Shaft ends				
	2	4	6	8		2	4	6,8		D,DA	E,EA	GA,GC	F,FA	DB,DC
63K+L	273	273	273	273	104	-	-	-	2x M25x1,5	11k6	23	12,5	4	M4
71K+L	334	334	334	334	111	25	25	25	2x M25x1,5	14k6	30	16	5	M5
80K+L	387	387	387	387	116	25	25	25	2x M25x1,5	19k6	40	21,5	6	M6
90L	445	445	445	445	137	25	25	25	2x M25x1,5	24k6	50	27	8	M8
100L	510	510	510	510	149	30	30	30	2x M32x1,5	28k6	60	31	8	M10
112M	524	524	524	524	154	30	30	30	2x M32x1,5	28k6	60	31	8	M10
132S+M	645	645	645	645	226	30	30	30	2x M32x1,5	38k6	80	41	10	M12
160M+L	863	831	831	831	261	35	35	35	2x M40x1,5	42k6	110	45	12	M16
180M	909	909	-	-	369	63	63	-	2x M40x1,5	48k6	110	51,5	14	M16
180L	-	909	909	909	369	-	63	63	2x M40x1,5	48k6	110	51,5	14	M16
200L	983	909	909	909	390	74	74	74	2x M50x1,5	55m6	110	59	16	M20

Type CD...	LC No. poles				LD No. poles			LE No. poles			O	Shaft ends D _{m6} , DA _{m6} ¹⁾			E,EA	GA,GC ¹⁾			F,FA ¹⁾		DB,DC ¹⁾	
	2	4	6	8	2	4,6,8	2	4	6,8	2		4	6,8	2		4,6,8	2	4	6+8	2	4,6,8	2
225S	-	1171	1171	1171	-	377	-	85	85	2x M50x1,5	-	60	60	-	140	-	64	64	-	18	-	M20
225M	1111	1171	1171	1171	347	377	85	85	85	2x M50x1,5	55	60	60	110	140	59	64	64	16	18	M20	M20
250M	1251	1251	1185	1185	482	482	94	94	94	2x M63x1,5	60	65	65	140	140	64	69	69	18	18	M20	M20
280S	1375	1375	1375	1375	483	483	110	110	110	2x M63x1,5	65	75	75	140	140	69	79,5	79,5	18	20	M20	M20
280M	1375	1375	1375	1375	483	483	110	110	110	2x M63x1,5	65	75	75	140	140	69	79,5	79,5	18	20	M20	M20
315S	1543	1573	1573	1573	496	526	115	115	115	2x M63x1,5	65	80	80	140	170	69	85	85	18	22	M20	M20
315M	1543	1573	1573	1573	496	526	115	115	115	2x M63x1,5	65	80	80	140	170	69	85	85	18	22	M20	M20
315L ₁	1543	1573	1573	1573	496	526	115	115	115	2x M63x1,5	65	80	80	140	170	69	85	85	18	22	M20	M20
315L ₂	1743	1773	1573	1573	496	526	115	115	115	2x M63x1,5	65	80	80	140	170	69	85	85	18	22	M20	M20
315L ₃	1743	1773	1773	1773	496	526	115	115	115	2x M63x1,5	65	80	80	140	170	69	85	85	18	22	M20	M20
355M	-	-	1980	1980	672	702	130	130	130	2x M80x2	75	90	90	140	170	79,5	95	95	20	25	M20	M24
355L ₁	1950	1980	1980	1980	672	702	130	130	130	2x M80x2	75	90	90	140	170	79,5	95	95	20	25	M20	M24
355L ₂	1950	1980	1980	1980	672	702	130	130	130	2x M80x2	75	90	90	140	170	79,5	95	95	20	25	M20	M24
355L ₃	2030	2060	-	-	672	702	130	130	130	2x M80x2	75	90	90	140	170	79,5	95	95	20	25	M20	M24
400S	-	2190	2190	2190	716	786	130	130	130	2x M95x2	75	100	100	140	210	79,5	106	106	20	28	M20	M24
400M	2120	2190	2190	2190	716	786	130	130	130	2x M95x2	75	100	100	140	210	79,5	106	106	20	28	M20	M24
400L	2120	2190	2190	2190	716	786	130	130	130	2x M95x2	75	100	100	140	210	79,5	106	106	20	28	M20	M24
450S	2140	2280	2280	2280	704	774	130	130	130	2x M95x2	75	100	110	140	210	79,5	106	116	20	28	M20	M24
450M	2140	2280	2280	2280	704	774	130	130	130	2x M95x2	75	100	110	140	210	79,5	106	116	20	28	M20	M24
450L ₁	2140	2280	2280	2280	704	774	130	130	130	2x M95x2	75	100	110	140	210	79,5	106	116	20	28	M20	M24
450L ₂	-	2425	2425	2425	704	774	130	130	130	2x M95x2	75	100	110	140	210	79,5	106	116	20	28	M20	M24

Surface-Cooled Low-Voltage Motors, Self-Cooling with Radial-Flow Fan

94

Version IM B14, IM B34,
IM V17¹⁾, IM V18¹⁾, IM V19, IM V37

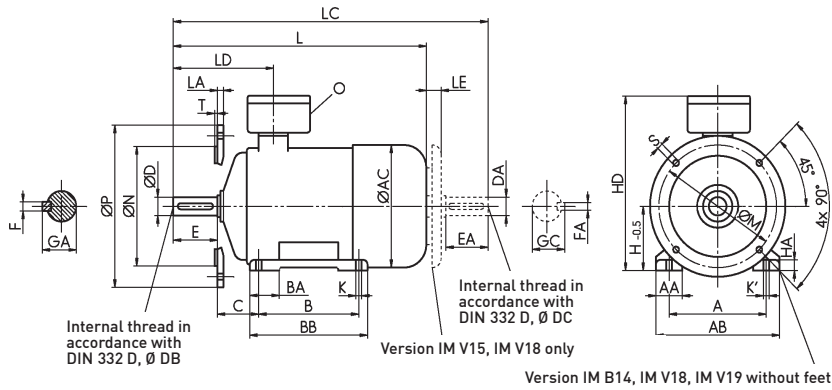

Frame size 63 in T4 without fan.
Mounting flange according to EN 50347 Form FT. Eye bolts from frame size 90.
Dimension AC measured over screw heads.
Dimension HD applies to Ex e box.
Terminal box can be rotated 4 x 90°.
Valid for series BD..., too

Note
1) Canopy necessary for versions IM V18 and IM V17

Type CD...	A	AA	AB	AC	B	BA	BB	C	H _{-0,5}	HA	HD	K	K'
63K+L	100	20	120	134	80	25	100	40	63	6	227	7	10
71K+L	112	30	139	145	90	25	110	45	71	10	235	7	10
80K+L	125	35	160	163	100	35	130	50	80	12	260	9,5	12
90L	140	40	180	183	125	40	155	56	90	12	275	9,5	12
100L	160	45	200	201	140	45	175	63	100	15	305	12	15

Type CD...	L	LC	LE	LD	O	Shaft ends D _{k6} , DA _{k6}	E, EA	GA, GC	F, FA	DB, DC
63K+L	239	273	-	104	2x M25x1,5	11	23	12,5	4	M4
71K+L	288	334	25	111	2x M25x1,5	14	30	16	5	M5
80K+L	313	387	25	116	2x M25x1,5	19	40	21,5	6	M6
90L	364	445	25	137	2x M25x1,5	24	50	27	8	M8
100L	415	510	30	149	2x M32x1,5	28	60	31	8	M10

Type CD...	Mounting flange LA	M	N _{j6}	P	S	T
63K+L	8	75	60	90	M5	2,5
	9	100	80	120	M6	3
71K+L	8	85	70	105	M6	2,5
	8	115	95	140	M8	3
80K+L	10	100	80	120	M6	3
	10	130	110	160	M8	3,5
90L	10	115	95	140	M8	3
	10	130	110	160	M8	3,5
100L	12	130	110	160	M8	3,5
	12	165	130	200	M10	3,5

Surface-Cooled Motors with Integrated Frequency Inverter

Version IM B3, IM B5, IM B6, IM B7, IM B8, IM B14,
IM B34, IM B35, IM V1¹⁾, IM V3, IM V5¹⁾, IM V6,
IM V15¹⁾, IM V17¹⁾, IM V18¹⁾, IM V19, IM V35, IM V37

95

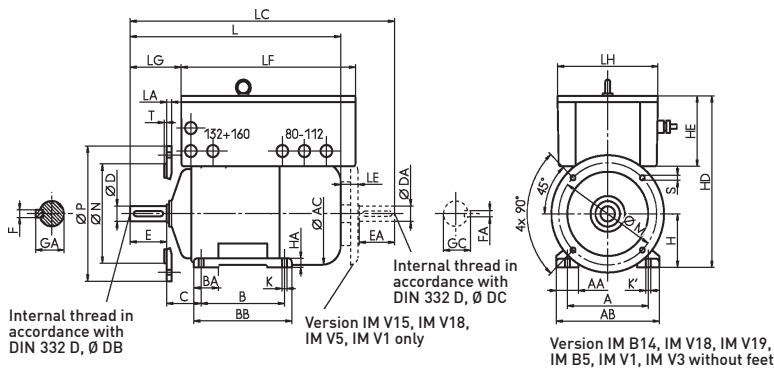

Mounting flange according to EN 50347
All motors with lifting lugs.
Dimension AC measured over screw heads.
Dimension HD applies to Ex e box.

Note

1) Versions IM V1, IM V5, IM V15, IM V17 and IM V18 with canopy

Type CD...I	A	AA	AB	AC	B	BA	BB	C	H _{-0,5}	HA	HD	K	K'	L	LC	LE	LF	LG	LH	HE	Weight approx. (kg)
80K+L	125	35	160	163	100	35	130	50	80	12	335	9,5	12	313	387	25	355	46	270	200	60
90L	140	40	180	183	125	40	155	56	90	12	350	9,5	12	364	445	25	355	67	270	200	67
100L	160	45	200	201	140	45	175	63	100	15	380	12	15	415	510	30	355	79	270	200	79
112L	190	50	235	225	140	50	175	70	112	17	390	12	15	423	524	30	355	84	270	200	93
132S	216	60	266	265	140	60	187	89	132	20	450	12	15	529	645	30	452	95	355	210	154
132M	216	60	266	265	178	60	225	89	132	20	450	12	15	529	645	30	452	95	355	210	164
160M-2	254	65	310	318	210	100	300	108	160	25	515	15	20	708	863	35	452	130	355	210	222
160M-4	254	65	310	318	210	100	300	108	160	25	515	15	20	708	863	35	452	130	355	210	227

Type CD...I	Shaft-end dimensions				Versions IM B35, IM B5 ¹⁾ , IM V1 ¹⁾ , IM V3, IM V15 ¹⁾ , IM V35							S	T
	D, DA	E, EA	GA, GC	F, FA	DB, DC	LA	M	N	P				
80K+L	19k6	40	21,5	6	M6	12	165	130j6	200	12	3,5		
90L	24k6	50	27	8	M8	12	165	130j6	200	12	3,5		
100L	28k6	60	31	8	M10	16	215	180j6	250	14,5	4		
112L	28k6	60	31	8	M10	16	215	180j6	250	14,5	4		
132S	38k6	80	41	10	M12	16	265	230j6	300	14,5	4		
132M	38k6	80	41	10	M12	16	265	230j6	300	14,5	4		
160M	42k6	110	45	12	M16	20	300	250j6	350	18,5	5		

Type CD...I	Versions IM B14, IM V18 ¹⁾ , IM V19, IM B34, IM V17 ¹⁾ , IM V37						Small flange					Large flange						
	LA	M	N	P	S	T	LA	M	N	P	S	T	LA	M	N	P	S	T
80K+L	10	100	80	120	M6	3	10	130	110j6	160	M8	3,5	10	130	110j6	160	M8	3,5
90L	10	115	95	140	M8	3	10	130	110j6	160	M8	3,5	10	130	110j6	160	M8	3,5
100L	12	130	110	160	M8	3,5	12	165	130j6	200	M10	3,5	12	165	130j6	200	M10	3,5

Surface-Cooled Low-Voltage Motors, Self-Cooling with Axial-Flow Fan

Noise class 2 and 3

Version IM B3, IM B6, IM B7, IM B8, IM V5¹⁾, IM V6

96

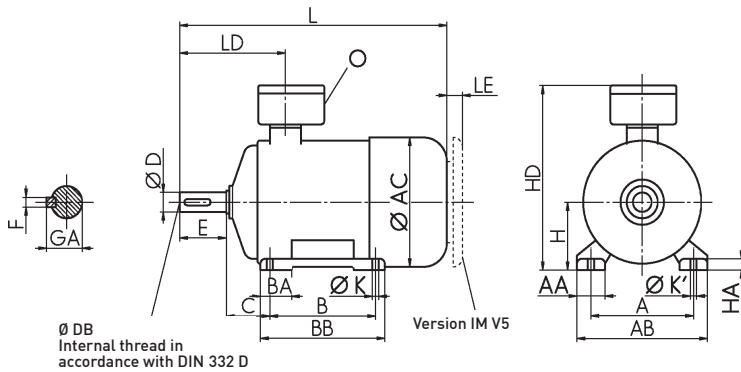

All motors with lifting lugs.
Dimension AC measured over screw heads.
Dimension HD applies to Ex e box.
Terminal box can be rotated 4 x 90°.
Valid for series BD..., too

Note

1) Canopy necessary for version IM V5, see dimension LE page 99

Type CD...A CD...AR	A	AA	AB	AC	B	BA	BB	C	H _{0,5}	HA	HD	K	K'
132S	216	60	266	265	140	60	187	89	132	20	411	12	15
132M	216	60	266	265	178	60	225	89	132	20	411	12	15
160M	254	65	310	318	210	100	300	108	160	25	477	15	20
160L	254	65	310	318	254	100	300	108	160	25	477	15	20
180M	279	75	350	353	241	100	340	121	180	25	545	15	20
180L	279	75	350	353	279	100	340	121	180	25	545	15	20
200L	318	80	390	393	305	90	365	133	200	30	581	20	26

Type CD...A CD...AR	A	AA	AB	AC	B	BA	BB	C	H	HA	HD	K	K'
225S	356	85	450	455	286	90	370	149	225 _{0,5}	35	634	20	26
225M	356	85	450	455	311	90	370	149	225 _{0,5}	35	634	20	26
250M	406	105	510	493	349	110	420	168	250 _{0,5}	40	721	26	35
280S	457	110	570	548	368	120	500	190	280 ₁	45	791	26	35
280M	457	110	570	548	419	120	500	190	280 ₁	45	791	26	35
315S	508	150	630	635	406	210	615	216	315 ₁	40	896	39	30
315M	508	150	630	635	457	210	615	216	315 ₁	40	896	39	30
315L ₁	508	150	630	635	508	210	615	216	315 ₁	40	896	39	30
315L ₂	508	150	630	635	508	210	615	216	315 ₁	40	896	39	30
315L ₃	508	150	630	635	508	210	615	216	315 ₁	40	896	39	30
355M	610	180	720	725	560	220	720	254	355 ₁	50	1084	30	39
355L ₁	610	180	720	725	630	220	720	254	355 ₁	50	1084	30	39
355L ₂	610	180	720	725	630	220	720	254	355 ₁	50	1084	30	39
355L ₃	610	180	720	725	630	220	720	254	355 ₁	50	1084	30	39

Type CD... A CD... AR	L No. poles		LD	O	Shaft ends				DB
	2	4			D	E	GA	F	
132S	582	582	226	2x M32x1,5	38k6	80	41	10	M12
132M	582	582	226	2x M32x1,5	38k6	80	41	10	M12
160M	732	732	261	2x M40x1,5	42k6	110	45	12	M16
160L	732	732	261	2x M40x1,5	42k6	110	45	12	M16
180M	741	741	369	2x M40x1,5	48k6	110	51,5	14	M16
180L	-	741	369	2x M40x1,5	48k6	110	51,5	14	M16
200L	798	804	390	2x M50x1,5	55m6	110	59	16	M20

Type CD... A CD... AR	L No. poles		LD No. poles		O	Shaft ends				DB					
	2	4	2	4		D _{m6} 2	4	E 2	4	GA 2	4	F 2	4	2	4
225S	-	918	-	377	2x M50x1,5	-	60	-	140	-	64	-	18	-	M20
225M	888	918	347	377	2x M50x1,5	55	60	110	140	59	64	16	18	M20	M20
250M	1001	1001	482	482	2x M63x1,5	60	65	140	140	64	69	18	18	M20	M20
280S	1110	1110	483	483	2x M63x1,5	65	75	140	140	69	79,5	18	20	M20	M20
280M	1110	1110	483	483	2x M63x1,5	65	75	140	140	69	79,5	18	20	M20	M20
315S	1218	1280	496	526	2x M63x1,5	65	80	140	170	69	85	18	22	M20	M20
315M	1218	1280	496	526	2x M63x1,5	65	80	140	170	69	85	18	22	M20	M20
315L ₁	1218	1280	496	526	2x M63x1,5	65	80	140	170	69	85	18	22	M20	M20
315L ₂	1418	1480	496	526	2x M63x1,5	65	80	140	170	69	85	18	22	M20	M20
315L ₃	1418	1480	496	526	2x M63x1,5	65	80	140	170	69	85	18	22	M20	M20
355M	-	-	672	702	2x M80x2	75	90	140	170	79,5	95	20	25	M20	M24
355L ₁	1627	1667	672	702	2x M80x2	75	90	140	170	79,5	95	20	25	M20	M24
355L ₂	1627	1667	672	702	2x M80x2	75	90	140	170	79,5	95	20	25	M20	M24
355L ₃	1707	1752	672	702	2x M80x2	75	90	140	170	79,5	95	20	25	M20	M24

Surface-Cooled Low-Voltage Motors, Self-Cooling with Axial-Flow Fan

Noise class 2 and 3

Version IM B5, IM V1¹⁾, IM V3

98

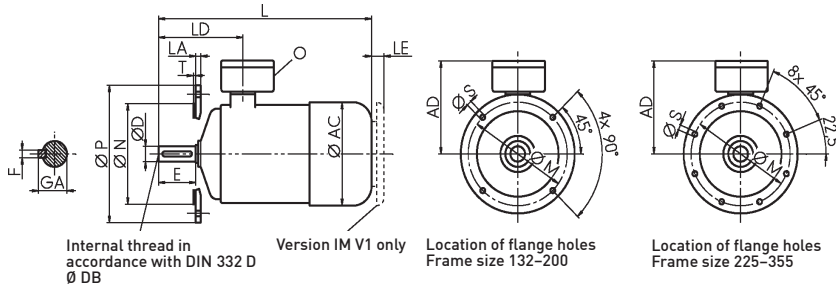

Mounting flange according to EN 50347
Form FF. All motors with lifting lugs.
Dimension AC measured over screw heads.
Dimension AD applies to Ex e box.
Terminal box can be rotated 4 x 90°.
Valid for series BD..., too

Note

1) Canopy necessary for version IM V1

Type ...A CD...AR	Mounting flange		N	P	S	T	AC	AD	L		LD
	LA	M							No. poles 2	4	
132S	16	265	230j6	300	14,5	4	265	279	582	582	226
132M	16	265	230j6	300	14,5	4	265	279	582	582	226
160M	20	300	250j6	350	18,5	5	318	317	732	732	261
160L	20	300	250j6	350	18,5	5	318	317	732	732	261
180M	20	300	250j6	350	18,5	5	353	365	741	741	369
180L	20	300	250j6	350	18,5	5	353	365	741	741	369
200L	20	350	300h6	400	18,5	5	393	381	798	804	390

Type ...A CD...AR	Mounting flange		N _{h6}	P	S	T	AC	AD	L		LD	
	LA	M							No. poles 2	4	No. poles 2	4
225S	22	400	350	450	18,5	5	455	409	-	918	-	377
225M	22	400	350	450	18,5	5	455	409	888	918	347	377
250M	18	500	450	550	18,5	5	493	471	1001	1001	482	482
280S	18	500	450	550	18,5	5	548	511	1110	1110	483	483
280M	18	500	450	550	18,5	5	548	511	1110	1110	483	483
315S	22	600	550	660	24	6	635	581	1218	1280	496	526
315M	22	600	550	660	24	6	635	581	1218	1280	496	526
315L ₁	22	600	550	660	24	6	635	581	1218	1280	496	526
315L ₂	22	600	550	660	24	6	635	581	1418	1480	496	526
315L ₃	22	600	550	660	24	6	635	581	1418	1480	496	526
355M	25	740	680	800	24	6	725	729	-	-	672	702
355L ₁	25	740	680	800	24	6	725	729	1627	1667	672	702
355L ₂	25	740	680	800	24	6	725	729	1627	1667	672	702
355L ₃	25	740	680	800	24	6	725	729	1707	1752	672	702

Type CD...A CD...AR	LE	O	Shaft ends					DB
			D	E	GA	F		
132S	30	2x M32x1,5	38k6	80	41	10	M12	
132M	30	2x M32x1,5	38k6	80	41	10	M12	
160M	35	2x M40x1,5	42k6	110	45	12	M16	
160L	35	2x M40x1,5	42k6	110	45	12	M16	
180M	63	2x M40x1,5	48k6	110	51,5	14	M16	
180L	63	2x M40x1,5	48k6	110	51,5	14	M16	
200L	74	2x M50x1,5	55m6	110	59	16	M20	

Type CD...A CD...AR	LE	O	Shaft ends									
			D _{m6}		E		GA		F		DB	
			2	4	2	4	2	4	2	4	2	4
225S	85	2x M50x1,5	-	60	-	140	-	64	-	18	-	M20
225M	85	2x M50x1,5	55	60	110	140	59	64	16	18	M20	M20
250M	95	2x M63x1,5	60	65	140	140	64	69	18	18	M20	M20
280S	110	2x M63x1,5	65	75	140	140	69	79,5	18	20	M20	M20
280M	110	2x M63x1,5	65	75	140	140	69	79,5	18	20	M20	M20
315S	125	2x M63x1,5	65	80	140	170	69	85	18	22	M20	M20
315M	125	2x M63x1,5	65	80	140	170	69	85	18	22	M20	M20
315L ₁	125	2x M63x1,5	65	80	140	170	69	85	18	22	M20	M20
315L ₂	125	2x M63x1,5	65	80	140	170	69	85	18	22	M20	M20
315L ₃	125	2x M63x1,5	65	80	140	170	69	85	18	22	M20	M20
355M	130	2x M80x2	75	90	140	170	79,5	95	20	25	M20	M24
355L ₁	130	2x M80x2	75	90	140	170	79,5	95	20	25	M20	M24
355L ₂	130	2x M80x2	75	90	140	170	79,5	95	20	25	M20	M24
355L ₃	130	2x M80x2	75	90	140	170	79,5	95	20	25	M20	M24

Surface-Cooled Low-Voltage Motors, External Cooling with Axial-Flow Fan

100

Version IM B3, IM B6, IM B7, IM B8, IM V5¹⁾, IM V6

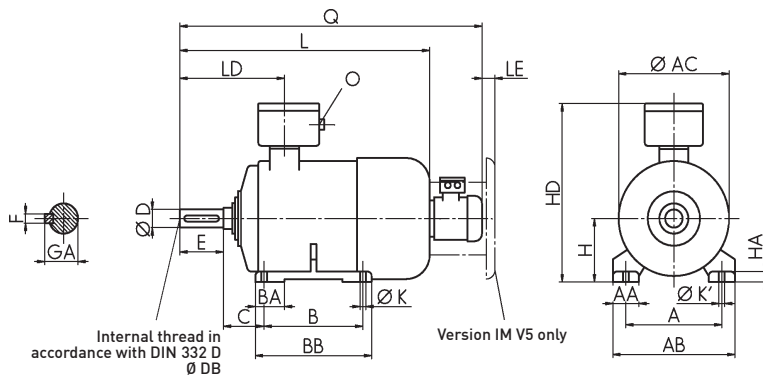

All motors with lifting lugs.
Dimension AC measured over screw heads.
Dimension HD applies to Ex e box.
Terminal box can be rotated 4 x 90°.
6 and 8-pole implementation on request.
Valid for series BD..., too

Note
1) Canopy required for version IM V5, see dimension LE page 103.

Type	Fan motor Type CD	A	AA	AB	AC	B	BA	BB	C	H _{0,5}	HA	HD	K	K'
112M	63K-4	190	50	235	225	140	50	175	70	112	17	317	12	15
132S	63K-4	216	60	266	265	140	60	187	89	132	20	411	12	15
132M	63K-4	216	60	266	265	178	60	225	89	132	20	411	12	15
160M	63K-4	254	65	310	318	210	100	300	108	160	25	477	15	20
160L	63K-4	254	65	310	318	254	100	300	108	160	25	477	15	20
180M	63K-4	279	75	350	358	241	100	340	121	180	25	545	15	20
180L	63K-4	279	75	350	358	279	100	340	121	180	25	545	15	20
200L	63K-4	318	80	390	393	305	90	365	133	200	30	581	20	26

Type	Fan motor Type CD	A	AA	AB	AC	B	BA	BB	C	H	HA	HD	K	K'
225S	63K-4	356	85	450	455	286	90	370	149	225 _{0,5}	35	634	20	26
225M	63K-4	356	85	450	455	311	90	370	149	225 _{0,5}	35	634	20	26
250M	63K-4	406	105	510	493	349	110	420	168	250 _{0,5}	40	721	26	35
280S	71L-4	457	110	570	548	368	120	500	190	280 ₁	45	791	26	35
280M	71L-4	457	110	570	548	419	120	500	190	280 ₁	45	791	26	35
315S	71L-4	508	150	630	635	406	210	615	216	315 ₁	40	896	39	30
315M	71L-4	508	150	630	635	457	210	615	216	315 ₁	40	896	39	30
315L ₁	71L-4	508	150	630	635	508	210	615	216	315 ₁	40	896	39	30
315L ₂	71L-4	508	150	630	635	508	210	615	216	315 ₁	40	896	39	30
315L ₃	71L-4	508	150	630	635	508	210	615	216	315 ₁	40	896	39	30
355M	80K-4	610	180	720	725	560	220	720	254	355 ₁	50	1084	30	39
355L ₁	80K-4	610	180	720	725	630	220	720	254	355 ₁	50	1084	30	39
355L ₂	80K-4	610	180	720	725	630	220	720	254	355 ₁	50	1084	30	39
355L ₃	80K-4	610	180	720	725	630	220	720	254	355 ₁	50	1084	30	39
400S	80L-4	686	120	800	810	560	150	870	280	400 ₁	34	1146	35	35
400M	80L-4	686	120	800	810	630	150	870	280	400 ₁	34	1146	35	35
400L	80L-4	686	120	800	810	710	150	870	280	400 ₁	34	1146	35	35
450S	90L1-4	760	150	900	910	630	180	790	280	450 ₁	35	1264	35	35
450M	90L1-4	760	150	900	910	710	180	870	280	450 ₁	35	1264	35	35
450L ₁	90L1-4	760	150	900	910	840	180	1000	280	450 ₁	35	1264	35	35
450L ₂	90L1-4	760	150	900	910	840	180	1000	280	450 ₁	35	1264	35	35

Note

1) Frame size 450-6,8 dimension D = 110

Type	L	Q	LD	O	Shaft ends				
CD...F					D	E	GA	F	DB
112M	513	729	154	2x M32x1,5	28k6	60	31	8	M10
132S	606	822	226	2x M32x1,5	38k6	80	41	10	M12
132M	606	822	226	2x M32x1,5	38k6	80	41	10	M12
160M	757	973	261	2x M40x1,5	42k6	110	45	12	M16
160L	757	973	261	2x M40x1,5	42k6	110	45	12	M16
180M	746	962	369	2x M40x1,5	48k6	110	51,5	14	M16
180L	746	962	369	2x M40x1,5	48k6	110	51,5	14	M16
200L	798	1014	390	2x M50x1,5	55m6	110	59	16	M20

Type	L		Q		LD		O	Shaft ends					DB				
CD...F	No. poles		No. poles		No. poles			D _{m6}	E	GA	F						
	2	4,6,8	2	4,6,8	2	4,6,8		2	4,6,8	2	4,6,8	2	4,6,8	2	4,6,8		
225S	-	938	-	1154	-	377	2x M50x1,5	-	60	-	140	-	64	-	18	-	M20
225M	908	938	1124	1154	347	377	2x M50x1,5	55	60	110	140	59	64	16	18	M20	M20
250M	1020	1020	1236	1236	482	482	2x M63x1,5	60	65	140	140	64	69	18	18	M20	M20
280S	1141	1141	1399	1399	483	482	2x M63x1,5	65	75	140	140	69	79,5	18	20	M20	M20
280M	1141	1141	1399	1399	483	482	2x M63x1,5	65	75	140	140	69	79,5	18	20	M20	M20
315S	1283	1313	1541	1571	496	526	2x M63x1,5	65	80	140	170	69	85	18	22	M20	M20
315M	1283	1313	1541	1571	496	526	2x M63x1,5	65	80	140	170	69	85	18	22	M20	M20
315L ₁	1283	1313	1541	1571	496	526	2x M63x1,5	65	80	140	170	69	85	18	22	M20	M20
315L ₂	1473	1503	1731	1761	496	526	2x M63x1,5	65	80	140	170	69	85	18	22	M20	M20
315L ₃	1473	1503	1731	1761	496	526	2x M63x1,5	65	80	140	170	69	85	18	22	M20	M20
355M	-	-	-	-	672	702	2x M80x2	75	90	140	170	79,5	95	20	25	M20	M24
355L ₁	1624	1654	1897	1927	672	702	2x M80x2	75	90	140	170	79,5	95	20	25	M20	M24
355L ₂	1624	1654	1897	1927	672	702	2x M80x2	75	90	140	170	79,5	95	20	25	M20	M24
355L ₃	1704	1734	1977	2007	672	702	2x M80x2	75	90	140	170	79,5	95	20	25	M20	M24
400S	-	1855	-	2130	716	786	2x M95x2	75	100	140	210	79,5	106	20	28	M20	M24
400M	1785	1855	2060	2130	716	786	2x M95x2	75	100	140	210	79,5	106	20	28	M20	M24
400L	1785	1855	2060	2130	716	786	2x M95x2	75	100	140	210	79,5	106	20	28	M20	M24
450S	1880	1950	2194	2264	704	774	2x M95x2	75	100 ¹⁾	140	210	79,5	106	20	28	M20	M24
450M	1880	1950	2194	2264	704	774	2x M95x2	75	100 ¹⁾	140	210	79,5	106	20	28	M20	M24
450L ₁	1880	1950	2194	2264	704	774	2x M95x2	75	100 ¹⁾	140	210	79,5	106	20	28	M20	M24
450L ₂	-	2095	-	2409	704	774	2x M95x2	75	100 ¹⁾	140	210	79,5	106	20	28	M20	M24

Surface-Cooled Low-Voltage Motors, External Cooling with Axial-Flow Fan

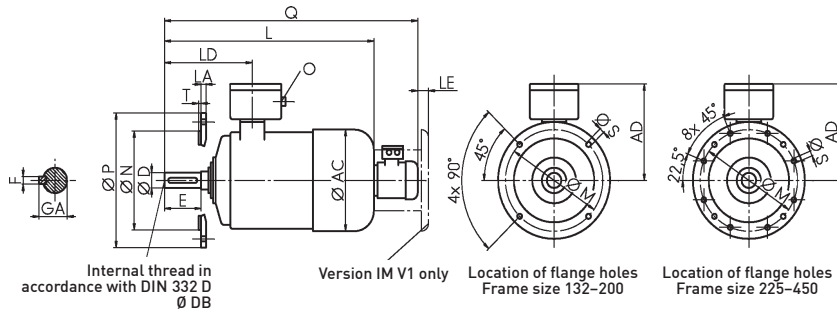

Fastening flange according to EN 50347 Form FF. All motors with lifting lugs.
Dimension AC measured over screw heads.
Dimension AD applies to Ex e box.
Terminal box can be rotated 4 x 90°.
Valid for series BD..., too

Frame size 400-450 available only in Version V1.

Note
1) Canopy necessary for Version IM V1.

Type	Fan motor	Mounting flange		N	P	S	T	AC	AD	L	Q
CD...F	Type CD	LA	M								
112M	63K-4	16	215	180 _{j6}	250	14,5	4	225	205	513	729
132S	63K-4	16	265	230 _{j6}	300	24,5	4	265	279	606	822
132M	63K-4	16	265	230 _{j6}	300	24,5	4	265	279	606	822
160M	63K-4	20	300	250 _{j6}	350	18,5	5	318	317	757	973
160L	63K-4	20	300	250 _{j6}	350	18,5	5	318	317	757	973
180M	63K-4	20	300	250 _{j6}	350	18,5	5	358	365	746	962
180L	63K-4	20	300	250 _{j6}	350	18,5	5	358	365	746	962
200L	63K-4	20	350	300 _{h6}	400	18,5	5	393	381	798	1014

Type	Fan motor	Mounting flange		N _{h6}	P	S	T	AC	AD	L		Q	
		LA	M							No. poles		No. poles	
CD...F	Type CD									2	4,6,8	2	4,6,8
225S	63K-4	22	400	350	450	18,5	5	455	409	-	938	-	1154
225M	63K-4	22	400	350	450	18,5	5	455	409	908	938	1124	1154
250M	63K-4	18	500	450	550	18,5	5	493	471	1020	1020	1236	1236
280S	71L-4	18	500	450	550	18,5	5	548	511	1141	1141	1399	1399
280M	71L-4	18	500	450	550	18,5	5	548	511	1141	1141	1399	1399
315S	71L-4	22	600	550	660	24	6	635	581	1283	1313	1541	1571
315M	71L-4	22	600	550	660	24	6	635	581	1283	1313	1541	1571
315L ₁	71L-4	22	600	550	660	24	6	635	581	1283	1313	1541	1571
315L ₂	71L-4	22	600	550	660	24	6	635	581	1473	1503	1731	1761
315L ₃	71L-4	22	600	550	660	24	6	635	581	1473	1503	1731	1761
355M	71L-4	25	740	680	800	24	6	725	729	-	-	-	-
355L ₁	71L-4	25	740	680	800	24	6	725	729	1624	1654	1897	1927
355L ₂	71L-4	25	740	680	800	24	6	725	729	1624	1654	1897	1927
355L ₃	71L-4	25	740	680	800	24	6	725	729	1704	1734	1977	2007
400S	80L-4	28	940	880	1000	28	6	810	746	-	1855	-	2130
400M	80L-4	28	940	880	1000	28	6	810	746	1785	1855	2060	2130
400L	80L-4	28	940	880	1000	28	6	810	746	1785	1855	2060	2130
450S	90L1-4	28	940	880	1000	28	6	910	814	1880	1950	2194	2264
450M	90L1-4	28	940	880	1000	28	6	910	814	1880	1950	2194	2264
450L ₁	90L1-4	28	940	880	1000	28	6	910	814	1880	1950	2194	2264
450L ₂	90L1-4	28	940	880	1000	28	6	910	814	-	2095	-	2409

Note

1) Frame size 450-6,8 dimension D = 110

Type	LD	LE	O	Shaft ends		GA	F	DB
CD...F				D	E			
112M	154	25	2x M32x1,5	28k6	60	31	8	M10
132S	226	26	2x M32x1,5	38k6	80	41	10	M12
132M	226	26	2x M32x1,5	38k6	80	41	10	M12
160M	261	26	2x M40x1,5	42k6	110	45	12	M16
160L	261	26	2x M40x1,5	42k6	110	45	12	M16
180M	369	31	2x M40x1,5	48k6	110	51,5	14	M16
180L	369	31	2x M40x1,5	48k6	110	51,5	14	M16
200L	390	61	2x M50x1,5	55m6	110	59	16	M20

Type	LD		LE	Shaft ends		E		GA		F		DB		
CD...F	No. poles	4,6,8		O	D _{m6}	2	4,6,8	2	4,6,8	2	4,6,8	2	4,6,8	
225S	-	377	31	2x M50x1,5	-	60	-	140	-	64	-	18	-	M20
225M	347	377	31	2x M50x1,5	55	60	110	140	59	64	16	18	M20	M20
250M	482	482	31	2x M63x1,5	60	65	140	140	64	69	18	18	M20	M20
280S	483	482	29	2x M63x1,5	65	75	140	140	69	79,5	18	20	M20	M20
280M	483	482	29	2x M63x1,5	65	75	140	140	69	79,5	18	20	M20	M20
315S	496	526	29	2x M63x1,5	65	80	140	170	69	85	18	22	M20	M20
315M	496	526	29	2x M63x1,5	65	80	140	170	69	85	18	22	M20	M20
315L ₁	496	526	29	2x M63x1,5	65	80	140	170	69	85	18	22	M20	M20
315L ₂	496	526	29	2x M63x1,5	65	80	140	170	69	85	18	22	M20	M20
315L ₃	496	526	29	2x M63x1,5	65	80	140	170	69	85	18	22	M20	M20
355M	672	702	35	2x M80x2	75	90	140	170	79,5	95	20	25	M20	M24
355L ₁	672	702	35	2x M80x2	75	90	140	170	79,5	95	20	25	M20	M24
355L ₂	672	702	35	2x M80x2	75	90	140	170	79,5	95	20	25	M20	M24
355L ₃	672	702	35	2x M80x2	75	90	140	170	79,5	95	20	25	M20	M24
400S	716	786	35	2x M95x2	75	100	140	210	79,5	106	20	28	M20	M24
400M	716	786	35	2x M95x2	75	100	140	210	79,5	106	20	28	M20	M24
400L	716	786	35	2x M95x2	75	100	140	210	79,5	106	20	28	M20	M24
450S	704	774	44	2x M95x2	75	100 ¹⁾	140	210	79,5	106	20	28	M20	M24
450M	704	774	44	2x M95x2	75	100 ¹⁾	140	210	79,5	106	20	28	M20	M24
450L ₁	704	774	44	2x M95x2	75	100 ¹⁾	140	210	79,5	106	20	28	M20	M24
450L ₂	704	774	44	2x M95x2	75	100 ¹⁾	140	210	79,5	106	20	28	M20	M24

Water-Cooled Low-Voltage Motors

Noise class 4

Version IM B3, IM B6, IM B7, IM B8, IM V5, IM V6

104

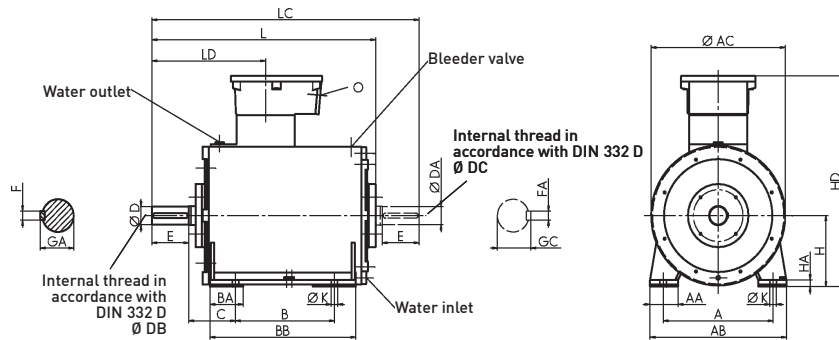

All motors with lifting lugs.
Dimension HD applies to Ex e box.
Terminal box can be rotated 4 x 90°.
Valid for series BD..., too

Type CD...W	A	AA	AB	AC	B	BA	BB	C	H	HA	HD	K
160M	254	65	310	317	210	100	300	108	160 _{-0,5}	15	477	15
160L	254	65	310	317	254	100	300	108	160 _{-0,5}	15	477	15
180M	279	75	350	454	241	100	340	121	180 _{-0,5}	15	545	15
180L	279	75	350	454	279	100	340	121	180 _{-0,5}	15	545	15
200L	318	80	390	385	305	90	365	133	200 _{-0,5}	20	581	20
225S	356	85	450	440	286	90	370	149	225 _{-0,5}	25	634	20
225M	356	85	450	440	311	90	370	149	225 _{-0,5}	25	634	20
250M	406	105	510	480	349	110	420	168	250 _{-0,5}	30	721	26
280S	457	110	570	536	368	120	500	190	280 ₋₁	35	791	26
280M	457	110	570	536	419	120	500	190	280 ₋₁	35	791	26
315S	508	150	630	619	406	210	615	216	315 ₋₁	35	896	30
315M	508	150	630	619	457	210	615	216	315 ₋₁	35	896	30
315L ₁	508	150	630	619	508	210	615	216	315 ₋₁	35	896	30
315L ₂	508	150	630	619	508	210	615	216	315 ₋₁	35	896	30
355M	610	130	720	702	560	220	720	254	355 ₋₁	35	1084	30
355L ₁	610	130	720	702	630	220	720	254	355 ₋₁	35	1084	30
355L ₂	610	130	720	702	630	220	720	254	355 ₋₁	35	1084	30

Note

1) For Type 250 to 400-4, 6, 8 dimension DA, EA, GC, FA, DC the specifications for pole number 2 apply.

For Type 450-6, 8 dimension DA, EA, GC, FA, DC the specifications for pole number 4 apply.

Type CD...W	L No. poles		LC No. poles		LD No. poles		O	Shaft ends		GA, GC ¹⁾	F, FA ¹⁾		DB, DC ¹⁾			
	2	4,6,8	2	4,6,8	2	4,6,8		D, DA ¹⁾	E, EA		2	4,6,8		2	4,6,8	
160M	641	641	755	755	261	261	2x M40x1,5	42k6	42k6	110	110	45	45	12	12	M16
160L	641	641	755	755	261	261	2x M40x1,5	42k6	42k6	110	110	45	45	12	12	M16
180M	643	643	773	773	369	369	2x M40x1,5	48k6	48k6	110	110	51,5	51,5	14	14	M16
180L	643	643	773	773	369	369	2x M40x1,5	48k6	48k6	110	110	51,5	51,5	14	14	M16
200L	660	660	773	773	390	390	2x M50x1,5	55m6	55m6	110	110	59	59	16	16	M20
225S	-	771	-	931	-	377	2x M50x1,5	-	60m6	-	140	-	64	-	18	M20
225M	741	771	871	931	347	377	2x M50x1,5	55m6	60m6	110	140	59	64	16	18	M20
250M	880	880	1040	1040	482	482	2x M63x1,5	60m6	65m6	140	140	64	69	18	18	M20
280S	983	983	1143	1143	483	483	2x M63x1,5	65m6	75m6	140	140	69	79,5	18	20	M20
280M	983	983	1143	1143	483	483	2x M63x1,5	65m6	75m6	140	140	69	79,5	18	20	M20
315S	1093	1123	1248	1308	496	526	2x M63x1,5	65m6	80m6	140	170	69	85	18	22	M20
315M	1093	1123	1248	1308	496	526	2x M63x1,5	65m6	80m6	140	170	69	85	18	22	M20
315L ₁	1093	1123	1248	1308	496	526	2x M63x1,5	65m6	80m6	140	170	69	85	18	22	M20
315L ₂	1293	1323	1448	1508	496	526	2x M63x1,5	65m6	80m6	140	170	69	85	18	22	M20
355M	1483	1783	1648	1978	672	702	2x M80x2	75m6	90m6	140	170	79,5	95	20	25	M24
355L ₁	1483	1783	1648	1978	672	702	2x M80x2	75m6	90m6	140	170	79,5	95	20	25	M24
355L ₂	1483	1783	1648	1978	672	702	2x M80x2	75m6	90m6	140	170	79,5	95	20	25	M24

Water-Cooled Low-Voltage Motors

Noise class 4

Version IM B5, IM V1, IM V3

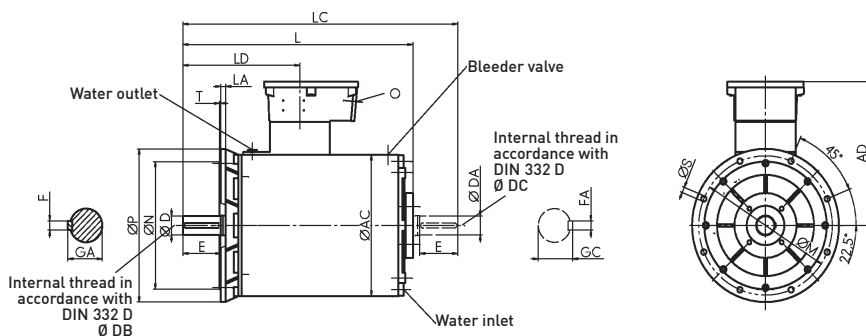

Mounting flange according to EN 50347 form FF. All motors with lifting lugs. Dimension AD applies to Ex e box. Terminal box can be rotated 4 x 90°. Valid for series BD..., too

Type CD...W	Mounting flange						AC	AD
	LA	M	N	P	S	T		
160M	20	300	250j6	350	18,5	5	317	317
160L	20	300	250j6	350	18,5	5	317	317
180M	20	300	250j6	350	18,5	5	454	365
180L	20	300	250j6	350	18,5	5	454	365
200L	20	350	300h6	400	18,5	5	385	381
225S	22	400	350h6	450	18,5	5	440	409
225M	22	400	350h6	450	18,5	5	440	409
250M	18	500	450h6	550	18,5	5	480	471
280S	18	500	450h6	550	18,5	5	536	511
280M	18	500	450h6	550	18,5	5	536	511
315S	22	600	550h6	660	24	6	619	581
315M	22	600	550h6	660	24	6	619	581
315L ₁	22	600	550h6	660	24	6	619	581
315L ₂	22	600	550h6	660	24	6	619	581
355M	25	740	680h6	800	24	6	702	729
355L ₁	25	740	680h6	800	24	6	702	729
355L ₂	25	740	680h6	800	24	6	702	729

Note

1) For Type 250 to 400-4, 6, 8 dimension DA, EA, GC, FA, DC the specifications for pole number 2 apply.

For Type 450-6, 8 dimension DA, EA, GC, FA, DC the specifications for pole number 4 apply.

Type CD...W	L No. poles		LC No. poles		LD No. poles		0	Shaft ends		2	GA, GC ¹⁾		F, FA ¹⁾		DB, DC ¹⁾	
	2	4,6,8	2	4,6,8	2	4,6,8		D, DA ¹⁾	E, EA		4,6,8	2	4,6,8	2		4,6,8
160M	641	641	755	755	261	261	2x M40x1,5	42k6	42k6	110	110	45	45	12	12	M16
160L	641	641	755	755	261	261	2x M40x1,5	42k6	42k6	110	110	45	45	12	12	M16
180M	643	643	773	773	369	369	2x M40x1,5	48k6	48k6	110	110	51,5	51,5	14	14	M16
180L	643	643	773	773	369	369	2x M40x1,5	48k6	48k6	110	110	51,5	51,5	14	14	M16
200L	660	660	773	773	390	390	2x M50x1,5	55m6	55m6	110	110	59	59	16	16	M20
225S	-	771	-	931	-	377	2x M50x1,5	-	60m6	-	140	-	64	-	18	M20
225M	741	771	871	931	347	377	2x M50x1,5	55m6	60m6	110	140	59	64	16	18	M20
250M	880	880	1040	1040	482	482	2x M63x1,5	60m6	65m6	140	140	64	69	18	18	M20
280S	983	983	1143	1143	483	483	2x M63x1,5	65m6	75m6	140	140	69	79,5	18	20	M20
280M	983	983	1143	1143	483	483	2x M63x1,5	65m6	75m6	140	140	69	79,5	18	20	M20
315S	1093	1123	1248	1308	496	526	2x M63x1,5	65m6	80m6	140	170	69	85	18	22	M20
315M	1093	1123	1248	1308	496	526	2x M63x1,5	65m6	80m6	140	170	69	85	18	22	M20
315L ₁	1093	1123	1248	1308	496	526	2x M63x1,5	65m6	80m6	140	170	69	85	18	22	M20
315L ₂	1293	1323	1448	1508	496	526	2x M63x1,5	65m6	80m6	140	170	69	85	18	22	M20
355M	1483	1783	1648	1978	672	702	2x M80x2	75m6	90m6	140	170	79,5	95	20	25	M24
355L ₁	1483	1783	1648	1978	672	702	2x M80x2	75m6	90m6	140	170	79,5	95	20	25	M24
355L ₂	1483	1783	1648	1978	672	702	2x M80x2	75m6	90m6	140	170	79,5	95	20	25	M24

Motors with Integral Brake

108

All versions

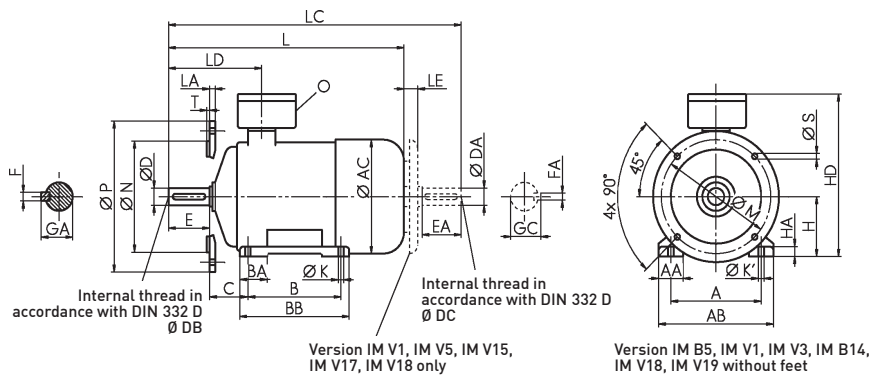

Fastening flange according to EN 50347
Form FF/FT. All motors with lifting lugs.
Dimension AC measured over screw heads.
Dimension HD applies to Ex e box.
Terminal box can be rotated 4 x 90°.

Type BD... B(R)	A	AA	AB	AC	B	BA	BB	C	H _{0,5}	HA	HD	K	K'	L	LC	LD	LE
80K+L	125	35	160	163	100	35	130	50	80	12	260	9,5	12	366,5	437	116	25
90L	140	40	180	183	125	40	155	56	90	12	275	9,5	12	421	502	137	25
100L	160	45	200	201	140	45	175	63	100	15	305	12	15	480,2	574	149	30
112M	190	50	235	225	140	50	175	70	112	17	317	12	15	497,5	597	154	30
132S	216	60	266	265	140	60	187	89	132	20	411	12	15	621	720	226	30
132M	216	60	266	265	178	60	225	89	132	20	411	12	15	621	720	226	30

Type BD... B(R)	0	Shaft ends D _{k6}		DA _{k6}	E	EA	GA	GC	F	FA	DB	DCB(R)
80K+L	2x M25x1,5	19	19	40	40	21,5	21,5	6	6	M6	M6	
90L	2x M25x1,5	24	24	50	50	27	27	8	8	M8	M8	
100L	2x M32x1,5	28	28	60	60	31	31	8	8	M10	M10	
112M	2x M32x1,5	28	28	60	60	31	31	8	8	M10	M10	
132S	2x M32x1,5	38	28	80	60	41	31	10	8	M12	M10	
132M	2x M32x1,5	38	28	80	60	41	31	10	8	M12	M10	

Type BD... B(R)	Mounting flange IM B5 LA		M	N _{j6}	P	S	T	LE
80K+L	12	165	130	200	12	3,5	25	
90L	12	165	130	200	12	3,5	25	
100L	16	215	180	250	15	4	30	
112M	16	215	180	250	15	4	30	
132S	16	265	230	300	15	4	30	
132M	16	265	230	300	15	4	30	

Type BD... B(R)	Mounting flange IM B14 LA		M	N _{j6}	P	S	T
80K+L	10	100	80	120	M6	3	
	10	130	110	160	M8	3,5	
90L	10	115	95	140	M8	3	
	10	130	110	160	M8	3,5	
100L	12	130	110	160	M8	3,5	
	12	165	130	200	M10	3,5	

Motors with External Brake

All versions

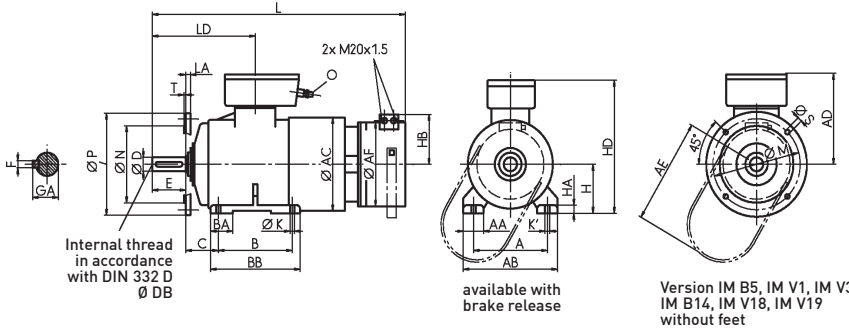

Mounting flange according to EN 50347 Form FF/FT. All motors with lifting lugs. Dimension AC measured over screw heads. Dimension AD, HD applies to Ex e box. Terminal box can be rotated 4 x 90°. Valid for series BD..., too.

Type CD (BD)...	A	AA	AB	AC	AD	B	BA	BB	C	H _{0,5}	HA	HD	K	K'	L	LD	O
80K+L	125	35	160	163	180	100	35	130	50	80 _{0,5}	12	260	9,5	12	454	116	2x M25x1,5
90L	140	40	180	183	185	125	40	155	56	90	12	275	9,5	12	502	137	2x M25x1,5
100L	160	45	200	201	205	140	45	175	63	100	15	305	12	15	602	149	2x M32x1,5
112M	190	50	235	225	205	140	50	175	70	112	17	317	12	15	609	154	2x M32x1,5
132S	216	60	266	265	279	140	60	187	89	132	20	411	12	15	715	226	2x M32x1,5
132M	216	60	266	265	279	178	60	225	89	132	20	411	12	15	715	226	2x M32x1,5
160M	254	65	310	318	317	210	100	300	108	160	25	477	15	20	881	261	2x M40x1,5
160L	254	65	310	318	317	254	100	300	108	160	25	477	15	20	881	261	2x M40x1,5
180M	279	75	350	353	365	241	70	340	121	180	25	545	15	20	924	369	2x M40x1,5
180L	279	75	350	353	365	279	70	340	121	180	25	545	15	20	924	369	2x M40x1,5
200L	318	80	390	393	381	305	90	365	133	200	30	581	20	26	942	390	2x M50x1,5

Type CD (BD)...	Mounting flange IM B5						Shaft ends						Brakes			Size
	LA	M	N	P	S	T	D	E	GA	F	DB	AE	AF	HB		
80K+L	12	165	130 _{j6}	200	12	3,5	19 _{k6}	40	21,5	6	M6	134	178	133	10	
90L	12	165	130 _{j6}	200	12	3,5	24 _{k6}	50	27	8	M8	134	178	133	10/11	
100L	15	215	180 _{j6}	250	15	4	28 _{k6}	60	31	8	M10	164	245	161	13	
112M	15	215	180 _{j6}	250	15	4	28 _{k6}	60	31	8	M10	164	245	161	13	
132S	15	265	230 _{j6}	300	15	4	38 _{k6}	80	41	10	M12	164	245	161	13/16	
132M	15	265	230 _{j6}	300	15	4	38 _{k6}	80	41	10	M12	164	245	161	13/16	
160M	19	300	250 _{j6}	350	19	5	42 _{k6}	110	45	12	M16	215	330	205	19	
160L	19	300	250 _{j6}	350	19	5	42 _{k6}	110	45	12	M16	215	330	205	19	
180M	19	300	250 _{j6}	350	19	5	48 _{k6}	110	51,5	14	M16	215	330	205	19/24	
180L	19	300	250 _{j6}	350	19	5	48 _{k6}	110	51,5	14	M16	215	330	205	19/24	
200L	19	350	300 _{h6}	400	19	5	55 _{rn6}	110	59	16	M20	215	330	205	24	

Type CD (BD)...	Mounting flange IM B14		N _{j6}	P	S	T
	LA	M				
80K+L	10	100	80	120	M6	3
	10	130	110	160	M8	3,5
90L	10	115	95	140	M8	3
	10	130	110	160	M8	3,5
100L	12	130	110	160	M8	3,5
	12	165	130	200	M10	3,5

Surface-Cooled High-Voltage Motors, Self-Cooling with Radial-Flow Fan

110

All versions

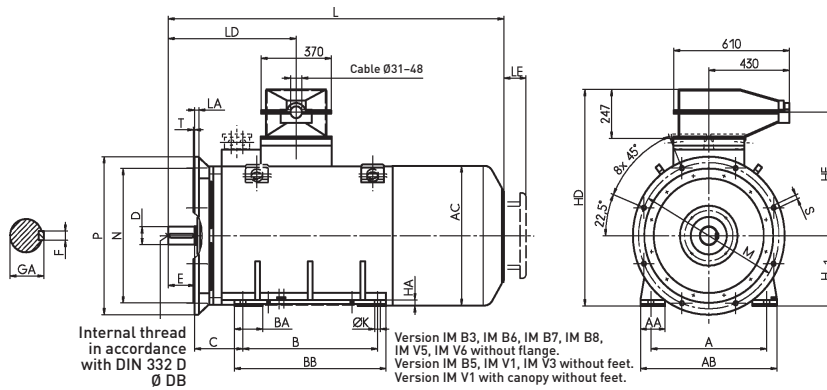

Fastening flange according to EN 50347 Form FF. All motors with lifting lugs. Dimension AC measured over screw heads. Dimension HD applies to Ex e box.

Note

1) Frame sizes 400 and 450 as a flange-mounting type available for V1 only.

Type ... H	A	AA	AB	AC	B	BA	BB	C	H ₁	HA	HD	HE	K	L		LD		LE
														No. poles 2	4, 6, 8	No. poles 2	4, 6, 8	
355M	610	180	720	725	560	220	720	254	355	50	1122	650	30/39 ¹⁾	1667	1697	672	702	130
355L	610	180	720	725	630	220	720	254	355	50	1122	650	30	1747	1777	672	702	130
400M	686	130	800	810	630	150	870	280	400	34	1184	655	35	1837	1907	716	786	130
400L	686	130	800	810	710	150	870	280	400	34	1184	655	35	1982	2052	716	786	130
450M	760	150	900	910	710	180	1000	280	450	35	1302	685	35	1850	1920	755	825	130
450L ₁	760	150	900	910	840	180	1000	280	450	35	1302	685	35	1995	2065	755	825	130
450L ₂	760	150	900	910	840	180	1000	280	450	35	1302	685	35	1995	2065	755	825	130
450L ₃	760	150	900	910	840	180	1000	280	450	35	1302	685	35	2175	2145	755	825	130

Type ... H	D _{m6} No. poles		E No. poles		GA No. poles		F No. poles		DB No. poles		Mounting flange					
	2	4, 6, 8	2	4, 6, 8	2	4, 6, 8	2	4, 6, 8	2	4, 6, 8	LA	M	N	P	S	T
355M	75	90	140	170	79,5	95	20	25	M20	M24	25	740	680 _{h6}	800	24	6
355L	75	90	140	170	79,5	95	20	25	M20	M24	25	740	680 _{h6}	800	24	6
400M	75	100	140	210	79,5	106	20	28	M20	M24	28	940	880 _{h6}	1000	28	6
400L	75	100	140	210	79,5	106	20	28	M20	M24	28	940	880 _{h6}	1000	28	6
450M	75	100	140	210	79,5	106	20	28	M20	M24	28	940	880 _{h6}	1000	28	6
450L ₁	75	100	140	210	79,5	106	20	28	M20	M24	28	940	880 _{h6}	1000	28	6
450L ₂	75	100	140	210	79,5	106	20	28	M20	M24	28	940	880 _{h6}	1000	28	6
450L ₃	75	100	140	210	79,5	106	20	28	M20	M24	28	940	880 _{h6}	1000	28	6

1) oval

Terminal Boxes to 690 V

Version 1, 3

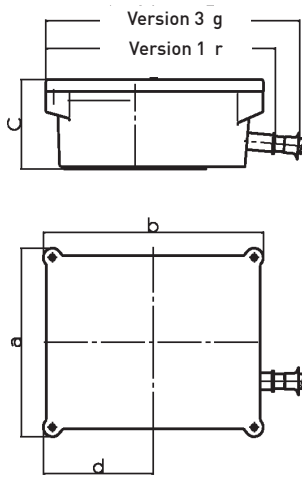

Version 9

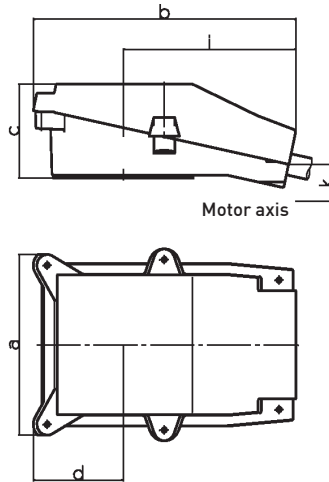

Version EEx d

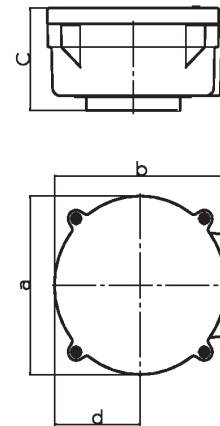

Box type Cable entry Frame size	EEx e Version 1+3						EEx d without cable entry			
	a	b	c	d	r	g	a	b	c	d
63	145	145	88	53	179	185	145	145	94	53
71	145	145	88	53	179	185	145	145	94	53
80	145	145	88	53	179	185	145	145	94	53
90	145	145	88	53	179	185	145	145	94	53
100	145	145	88	53	185	200	145	145	94	53
112	145	145	88	53	185	200	145	145	94	53
132	220	220	117	110	260	275	220	220	120	110
160	220	220	117	110	265	281	220	220	120	110
180	280	340	152	140	385	401	265	270	162	133
200	280	340	152	140	390	420	265	270	162	133
225	280	340	154	140	390	420	380	380	202	190
250	340	422	196	161	474	512	380	380	202	190
280	340	422	196	161	474	512	380	380	202	190
315	340	422	198	161	474	512	380	380	202	190
355	480	527	249	224	-	617	484	734	335	242
400	480	527	249	224	-	630	484	734	335	242
450	480	527	249	224	-	630	484	734	335	242

Box type Cable entry Frame size	EEx e Version 9				
	a	b	c	d	k
250	356	512	186	179	317
280	356	512	186	179	357
315	356	512	186	179	427
355	415	621	249	221	541
400	415	621	249	221	558
450	415	621	249	221	626

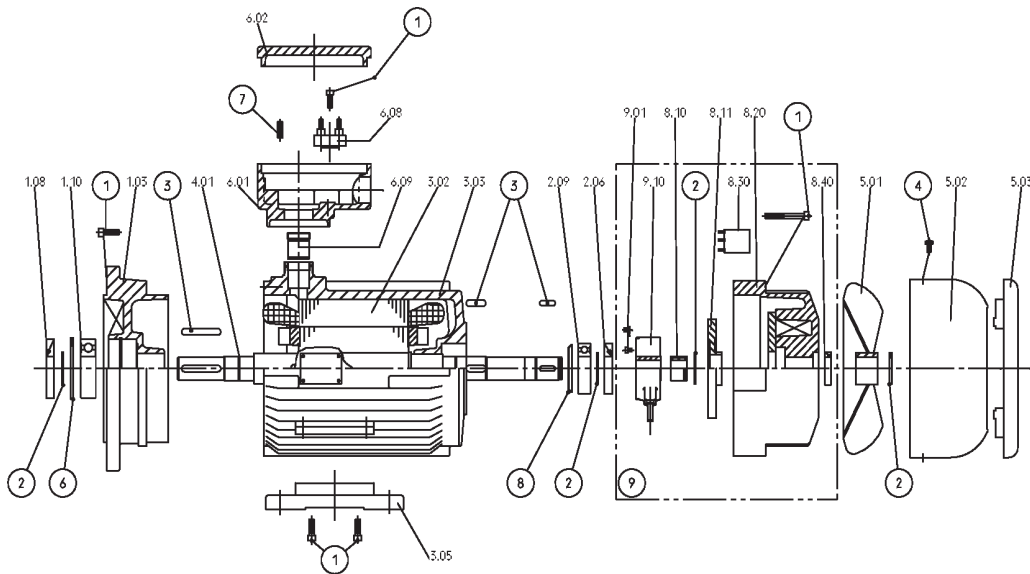

Exploded drawing frame size 63 to 132

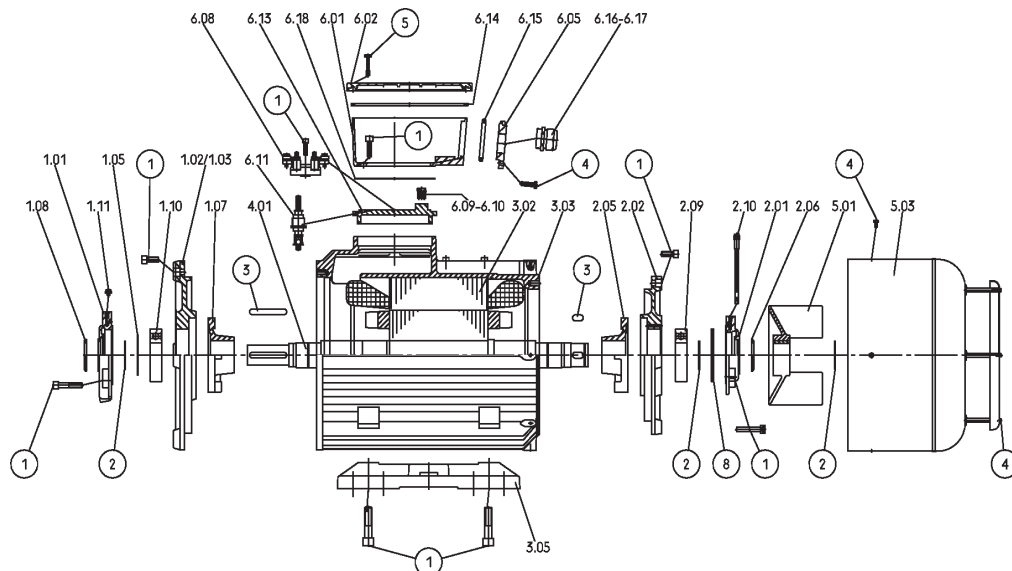

Exploded drawing frame size from 160

- | | | |
|--|--|--|
| ① Bolt in accordance with DIN 912 | ④ Bolts in accordance with EN 24017 | ⑦ Headless pins in accordance with DIN 914 |
| ② Retaining rings in acc. with DIN 471 | ⑤ Bolts in accordance with DIN 7964 | ⑧ Cup springs or compensation disks |
| ③ Parallel key in accordance with DIN 6885 | ⑥ Retaining rings in acc. with DIN 472 | ⑨ Only in case of brake motors and motors with built-in tachogenerator |

The listed spare parts are available ex-works. Version and combination depends on the motor supplied.

In case of inquiry and ordering spare parts, the following specifications are necessary:

- Part number and construction designation
- Motor type and version
- Motor number

Spare part list

Part No.	Designation
1	Drive end bearing
1.01	Drive end bearing crown external
1.02	Drive end end shield
1.03	Flange bearing plate drive end
1.05	Drive end regulator disk external
1.07	Drive end bearing crown internal
1.08	Drive end shaft seal
1.10	Drive end roller bearing
1.11	Drive end relubrication
2	Non-drive end bearing
2.01	Non-drive end bearing crown external
2.02	Non-drive end end shield
2.05	Non-drive bearing crown internal
2.06	Non-drive end shaft seal
2.08	Belleville spring
2.09	Non-drive end roller bearings
2.10	Non-drive end relubrication
3	Casing
3.02	Stator winding complete
3.03	Casing
3.05	Casing feet (1 pair)
4	Rotor
4.01	Rotor complete
5	Ventilation
5.01	Fan
5.02-03	Fan hood
6	Terminal compartment
6.01	Terminal box
6.02	Terminal box cover plate
6.05	Cable inlet plate
6.08	Switchboard
6.09	Core implementation
6.11	Cable penetration
6.13	Feedthrough plate
6.14	Terminal box cover plate gasket
6.15	Entry plate gasket
6.16-17	Cable inlet
6.18	Feedthrough plate gasket
8	Brake
8.10	Contact plate carrier
8.11	Contact plate
8.20	Braking-casing with reactance coil complete
8.30	One-way rectifier
8.40	Shaft seal
9	Tachogenerator
9.01	Tachogenerator
9.10	Torque support stay
9.20	Transmitter casing
9.40	Shaft seal

Conversion Factors for Technical Units of Measurement

to SI units
(Systeme Internationale d'Unitée)

114

Power

1 kW = 1,36 PS = 102 kpm/s = 1000 Nm/s
1 HP = 0,736 kW = 75 kpm/s = 736 Nm/s

Energy

1 kWh = $3,6 \times 10^6$ J = $3,6 \times 10^6$ Nm
= $0,367 \times 10^6$ kpm
1 Ws = 1 J = 1 Nm = 0,102 kpm

Force

1 N = 0,102 kp
1 kp = 9,81 N

Torque

1 Nm = 0,102 kpm = 1 Ws
1 kpm = 9,81 Nm = 9,81 Ws

Pressure

1 Pa = 1 N/m²
1 bar = 100 kPa
1 mm water column = 9,81 Pa

Moment of inertia

1 kgm² = 1 Ws² = 1 Nms² = 0,102 kpm²

Power (three-phase motors)

$P_1 = U \times I \times \cos \varphi \times \sqrt{3} \times 10^{-3}$
 $P_2 = P_1 \times \eta$
P₁ = absorbed power [kW]
P₂ = power output [kW]
U = voltage [V]
I = current [A]
cos φ = power factor
η = efficiency

Power requirements of some driven machines

Lift movement

$P = \frac{F \times v}{\eta} \times 10^{-3}$ [kW]

Rotation movement

$P = \frac{M \times n}{9550 \times \eta}$ [kW]

Fan operation

$P = \frac{V \times p}{\eta} \times 10^{-3}$ [kW]

Pump operation

$P = \frac{V \times p}{\eta} \times 10^{-3}$ [kW]

P = power [kW]
F = force [N]
v = speed [m/s]
η = efficiency
M = torque [Nm]
n = speed [rpm]
V = flow rate [m³/s]
p = overall back pressure [N/m²]

Torque

Torque from motor output

$M = 9550 \frac{P_2}{n}$ [Nm]

P₂ = power output [kW]
n = speed [rpm]

Conversion of torques for transmission ratios

$M_2 = \frac{M_1 \times n_1}{n_2}$

n₁ = motor speed [rpm]
M₁ = motor torque [Nm]
n₂ = working speed [rpm]
M₂ = torque at n₂ [Nm]

Moment of inertia

Relationship with flywheel effect

$J = \frac{GD^2}{4}$

J = moment of inertia [kgm²]
GD² = flywheel effect [kgm²]

Moment of inertia of linearly moving masses in relation to motor speed

$J = 91,2 \times m \left(\frac{v}{n}\right)^2$ [kgm²]

m = mass [kg]
v = speed [m/s]
n = motor speed [rpm]

Conversion of moments of inertia to different speeds for varying transmission ratios

$J_2 = J_1 \left(\frac{n_1}{n_2}\right)^2$

n₁ = motor speed
J₁ = moment of inertia at n₁
n₂ = working speed
J₂ = moment of inertia at n₂

Inertia factor

$FI = \frac{J_{mot} + J_{zus}}{J_{mot}}$

J_{mot} = moment of inertia, motor
J_{zus} = moment of inertia, driven machine

Starting time

$t_a = \frac{FI \times J_{mot} \times n}{9,55 \times M_b}$ [s]

M_b = M_{mot} - M_{geg} [Nm]
FI = inertia factor
J_{mot} = moment of inertia, motor [kgm²]
n = motor speed [rpm]
M_b = acceleration torque [Nm]
M_{mot} = motor torques during acceleration (averaged)
M_{geg} = load torque during acceleration (averaged)

Acoustics formulae

Sound pressure

$L_p = 20 \log \frac{p}{p_o}$ [dB]

Reference sound pressure

$p_o = 2 \times 10^{-5} \left[\frac{N}{m^2}\right]$

Sound power level

$L_w = 10 \log \frac{P}{P_o}$ [dB]

Reference sound power

$P_o = 10^{-12}$ [W]

Sound power

$P = \frac{p^2}{\alpha \times c} A$ [W]

Characteristic sound impedance

$\alpha \times c = 408 \left[\frac{N \cdot s}{m^3}\right]$
at 100 mbar
and 20 °C

Measuring-surface level

$L_s = 10 \log \frac{A}{A_o}$

$L_w = L_p + L_s$

L_p = sound pressure level [dB]
p = sound pressure $\left[\frac{N}{m^2}\right]$
p_o = reference sound pressure

L_w = sound power level [dB]
P = sound power [W]

P_o = reference sound power [W]
A = emitting surface [m²]

$\alpha \times c$ = characteristic sound impedance $\left[\frac{N \cdot s}{m^3}\right]$

A_o = reference surface area = 1 m²

L_s = measuring-surface level [dB]

Your Points of Contact in Germany

115

Werk Nordenham

ATB Motorentechnik GmbH
Helgoländer Damm 75
26954 Nordenham
Tel: +49 (0) 4731-365-0
Fax: +49 (0) 4731-365-1 59

Ihre Ansprechpartner

Österreich
ATB Austria
Antriebstechnik AG
G.-Bauknecht-Str.1
A-8724 Spielberg
Tel: +43 3577 757-0
Fax: +43 3577 757-81 838
E-Mail: Sabine.Woelfler@atb.co.at

Schweiz
ATB Schweiz AG
Industriestraße 28
5600 Lenzburg
Tel.: +41 (0) 62 88 57 010
Fax. +41 (0) 41 4 22 19 01

Ihre Servicepartner

Alessandri GmbH
Engelsdorfer Str. 31
50321 Brühl
Tel: +49 (0)2232/18 07 0
Fax: +49 (0)2232 18 07 11
E-Mail: info.@alessandri.de

Gero Huber
Elektromaschinenbau
Baseler Str. 4
79639 Grenzach-Wyhlen
Tel: +49(0) 7624-5638
Fax: +49(0) 7624-1572

R+M Industrietechnik Höchst
GmbH
Industriepark Höchst 629
65926 Frankfurt/Main
Tel: +49 (0) 69 305 80837
Fax: +49 (0) 69 30517633
E-Mail: Stefan.Dornick@rum.de

VSK Technik Kübler GmbH
Mittelrheinstraße 9
67550 Worms
Tel: +49 (0) 6242-9 11 63-0
Fax: +49 (0) 6242-9 11 63-99
E-Mail: motoren@vsk.de

Ihre Ansprechpartner weltweit

116

Standorte

Deutschland

ATB Motorentchnik GmbH
Helgoländer Damm 75
26954 Nordenham
Tel: +49 (0) 4731.365-0
Fax: +49 (0) 4731-365-159
E-Mail: info@atb-nordenham.de

ATB Antriebstechnik GmbH
Silberstraße 74
73642 Welzheim
Tel: +49 (0) 7182-14-1
Fax: +49 (0) 7182-590
E-Mail: info@atb.de

Österreich

ATB Austria
Antriebstechnik AG
G.-Bauknecht-Straße 1
A-8724 Spielberg
Tel: +43 (0) 3577-757-0
Fax: +43 (0) 3577-757-182
E-Mail: info@atb-motors.com

ATB TECHNOLOGIES GMBH
a company of
A-TEC INDUSTRIES AG
Millennium Park 11
A-6890 Lustenau
Tel: +43 (0) 5577 9010 -351
Fax: +43 (0) 5577 9010 -350
E-Mail: info@atb-motors.com

Frankreich

ATB SELNI SAS
6 Rue Louise Michel, BP 24
58028 Nevers Cedex
Tel: +33 (3) 86 93 42 00
Fax: +33 (3) 86 93 44 22
E-Mail: info@atbselni.fr

Serbien Montenegro

ATB SEVER a.d.
Serbien&Montenegro
Magneta polja 6
24000 Subotica
Tel: +381 (24) 548-111
: +381 (24) 548-222
Fax: +381 (24) 546-893
E-Mail: sever@yu.atb-motors.com

Großbritannien

ATB Morley Ltd.
Bradford Road
Leeds
West Yorkshire
LS 286 QA
Tel: +44 (113) 257 17 34
Fax: +44 (113) 257 07 51
E-Mail: sales@uk.atb-motors.com

Tschechien

ATB Components S.R.O.
Lihovarska 1335/9
CZ-71610 Ostrave-Radvanice
Tel: +420 (59) 62 333-40
Fax: +420 (59) 62333 40
E-Mail: atb.bastro@quick.cz

Weitere Kontakte

Asien

ATB Motorentchnik (ASIA)
PTE.LTD
Singapore Head Office
3 Toh Tuck Link # 02-01
German-Distri Centre
Singapore 596228
Tel: +65 64668773
Fax: +65 64664844
E-Mail: K.lane@atbs.com.sg

Australien

TOSHIBA INTERNATIONAL
CORP.PTY.LTD.
2 Morton Street
NSW 2150 Parramatta
Tel: +61 (29) 76 86 600
Fax: +61 (29) 89 07 546
E-Mail: bond@tic.toshiba.com.au

Belgien

MAMMOET INDUSTRIES N.V.
Terlindenhofstraat 36
2170 Antwerpen-Merksem
Tel: +31 (36) 44 54 55
Fax: +31 (36) 44 32 78
E-Mail: patrick.mattelaer@mam-
moetindustries.be

China

ATB MOTORS (SHANGHAI)
CO.LTD.
Section E, Floor 1, Building 28
No. 500 East Fute 2nd Road,
Free Trade Zone Wai Gao Qiao
200131 Shanghai
Tel: +86 (21) 50461928
Fax: +86 (21) 5046 3362
E-Mail: info@cn.atb-motors.com

Dänemark

BRODRENE EEGHOLM A/S
Grundtvigs Alle 165-169
6400 Sonderborg
Tel: +45 73 12 12 39
Fax: +45 73 12 12 13
E-Mail: paj@eegholm.dk

Frankreich

ATB France SARL
6.rue Louise Michel BP 24
58028 NEVERS Cedex
Tel: +33 3 86 93 42 32
Fax: +33 3 86 93 42 31
E-Mail:
jean-michel.pignon-heriard@atb-
france.fr

Irland

AVONMORE ELECTRICAL Co.
LTD.
Roskeen, Mallow
Co. Cork / Irland
Tel: +35 (3) 224 74 77
Fax: +35 (3) 224 74 64
E-Mail:
derry@avonmore- electrical.com

Italien

MAZZERI S.R.L.
Via Teodosio, 65
20131 Mailand
Tel: +39 (02) 28 71 161
Fax: +39 (02) 28 28 636
E-Mail: mazzeri@mazzeri.it

Kuwait

CANNAR TRADING AND
CONSTRUCTION CO.
P.O.BOX 1322
10314 Safat

Niederlande

ATB BENELUX B.V.
Tasveld 14
8271 RW IJsselmuiden- NL
Tel: +31 (0) 38 4432110
Fax: +31 (0) 38 4432111
E-Mail: verkoop@atbaandrijftech-
niek.nl

Norwegen

LANNE ELEKTRISKE VERKSTED
P.O. Box 1088 Hillevåg,
Fridtjof Nansensveg 68 a
4095 Stavanger
Tel: +47 (51) 82 75 75
Fax: +47 (51) 82 75 76
E-Mail: janegil@lanne.no

Schweden

ATB DRIVTECH AB
Box 109
Ringvägen 4
17822 Ekerö
Tel: +46 (8) 560 34692
Fax: +46 (8) 560 34693
E-Mail: bjoern.sahlsten@atbdri-
vtech.se

Schweiz

ATB Schweiz AG
Industristraße 28
5600 Lenzburg
Tel: +41 (0) 62 8 85 70 10
Fax: +41 (0) 41 44 22 19 01

Thailand

ENSYS CO.LTD.
636/4 Soi Ramkhamhaeng 39
Thepleela 1
Pracho Uthit Road,
Wangthonglang,
Bangkok 10310, Thailand
Tel: +66 (26) 42 69 02
Fax: +66 (26) 42 69 04

Tschechische Republik

ATB BRNO-
Ing. Frantisek Vojta
Okruzni 25
63800 Brno
Tel: +420 (5) 45 222 399
Fax: +420 (5) 45 222 399
E-Mail: vojta@brno.comp.cz

Ungarn

CONTRADEX
KERESKEDELIMI KFT.
Budakeszi ut 51
1021 Budapest
Tel: +36 (1) 394 1567
Fax: +36 (1) 394 3881
E-Mail: contradex.axelero.hu

Servicepartners

Australien

AUSTRALIA, NEW ZEALAND
TOSHIBA INTERNATIONAL CORP
PTY LTD
2 Morton Street
Parramatta
NSW 2150
AUSTRALIA
Tel: + 61 2 9768 6600
Fax: +61 2 9890 7546
E-Mail: bond@tic.toshiba.com.au
Web: www.toshiba.com.au

Großbritannien

SATTERGOOD & JOHNSON
LIMITED
Lowfields Road
Leeds
LS 12 6ET
Tel: +44 (0) 113 243 0203
Fax: +44 (0) 113 242 0959
E-Mail: hazsales@scatts.co.uk
Web: www.scatts.Co.uk

POWER TRANSMISSION EQUIPMENT

Unit 12 Spires Business Units
Mugiemoss Road
Bucksburn
Aberdeen
AB 21 9 NY
Tel: +44 (0) 1224 680022
Fax: +44 (0) 1224 680033
E-Mail: sales@pte-ltd.fsnet.co.uk

ATB Morley
Bradford Road
Leeds
West Yorkshire
LS 286 QA, England
Tel: +44 (113) 2 57 17 34
Fax: +44 (113) 2 57 07 51

Malaysia

PLANT & MAINTENANCE
ENGINEERING SDN BHD
Unit 6 Kompleks Hamodal I Lot
605
Jalan SS 13/KSJ
MALAYSIA 47500
Tel: +60 3 5636 0605
Fax: +60 3 5636 9788
E-Mail: enquiry@pme.com.my
Web: www.pme.com.my

Singapur

HEAD OFFICE ASIA PACIFIC
ATB MOTORENTECHNIK (ASIA)
PTE LTD
3 Toh Tuck Link
02-01 German Districentre
SINGAPORE 596228
Tel: +65 6466 8773
Fax: +65 6463 7571
E-Mail: samng@atbs.com.sg
Web: www.atb.co.at

MAIN SERVICE PARTNER
ASIA PACIFIC
MAINTECH ENGINEERING &
SUPPLIES PTE LTD
7 Joo Koon Crescent
SINGAPORE 629024
Tel: +65 6862 5224
Fax: +65 6861 5225
E-Mail: bcbong@mes.com.sg
Web: www.mes.com.sg

Thailand

ENSYS MOTORS AND
DRIVES CO LTD
636/4 Soi Ramkhamhaeng 39
Thepleela 1 Pracha Uthit Road
Wanthonglang, Bangkok 10310
Thailand
Tel: +66 2934 5820
Fax: +66 2934 5192
E-Mail: sales@ensys.co.th

China

Tatung Co.
Chedun Town
Songjiang District
CN-Shanghai 201611
jameshuang@tatung.com
Tel: + 86 21 57 60 5299
Fax: + 86 21 57 60 5266

**Further service partners
on request.**

Publisher

ATB MOTORENTECHNIK GMBH
Helgoländer Damm 75
26954 Nordenham, Germany
Tel.: +49 (0)4731 365-0
Fax: +49 (0)4731 365-159
E-Mail: info@atb-nordenham.de
Web: www.atb-nordenham.de

Edition

EXMOT 05 EN

Subject of modifications reserved.
Reprint with our written
authorisation, only.



ATB MOTORENTECHNIK GMBH
Helgoländer Damm 75
26954 Nordenham, Germany
Tel.: +49 (0)4731 365-0
Fax: +49 (0)4731 365-159
E-Mail: info@atb-nordenham.de
Web: www.atb-nordenham.de

EXMOT 06 EN