

WEMO 3-5 LINEAR PICKER

Linear servo picker for sprue and part handling

Take the first step toward smarter automation with the Wemo 3-5 Linear Picker – the next-generation alternative to traditional pneumatic sprue pickers. Compact, flexible, and energy-efficient, this innovative solution is designed to do more than just sprue handling. With capabilities that extend to more advanced automation processes, the 3-5 LP positions your production for the future.



Its compact design integrates seamlessly within the machine guard, eliminating the need for external safety barriers and reducing floor space usage. The servo motor technology delivers exceptional precision while consuming significantly less energy than pneumatic systems, helping you cut costs and meet sustainability goals. Combined with intuitive programming, the 3-5 LP makes it easier than ever to streamline operations, boost efficiency, and prepare for more sophisticated automation.

Standard version with sprue gripper

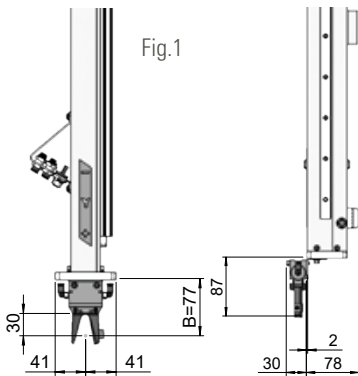

Optional with C-axis

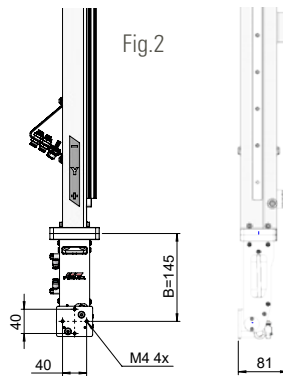

Optional with B & C-axis

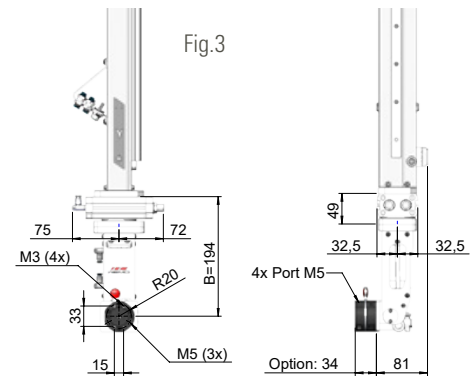

ADVANTAGES 3-5 Linear Picker for sprue & part handling

- ✓ Easy and user friendly programming
- ✓ Low operating costs
- ✓ Space saving
- ✓ Installed preferably inside machine guarding for a compact solution

Why choose the Wemo 3-5 Linear picker?

- **A first step toward full automation:** More than a sprue picker, the 3-5 LP is designed to handle additional automation tasks, making it an excellent gateway to upgrading your production capabilities.
- **Flexible installation:** Integrate directly within the molding machine for a compact setup or mount conventionally above machine guarding for extended stroke applications.
- **Energy-efficient design:** The combination of servo motor technology and an energy-saving vacuum circuit significantly reduces energy consumption compared to pneumatic solutions.
- **Enhanced functionality:** Tailor the 3-5 LP to your production needs with options like extended stroke lengths, wrist-axis movement, and additional vacuum circuits.
- **Seamless integration:** Compact, space-saving design ensures fast and hassle-free installation without external safety barriers.



YUSHIN GROUP



www.wemogroup.com/en