



Cable and pipe seals

FOR CONSTRUCTION APPLICATIONS

We Seal Your World™



ABOUT ROXTEC

- The world's leading provider of multi-cable and pipe transits
- Founded in Sweden in 1990
- Inventor of Multidiameter™
- Local support in more than 70 markets
- Certified according to ISO 9001/14001 and EN 13980
- More than 250 product certifications and safety listings

More than a firestop

The Roxtec sealing system for cables and pipes protects against fire – but also against gas, water, and several other risk factors. Our solutions are easy to use and help you ensure safety, efficiency and operational reliability through all phases of your construction project.



Cable and pipe penetrations are often overlooked on construction projects, yet they can eventually become a major problem for a building owner. These penetrations often become “the weakest link” in the integrity of the structure.

Complete protection

Fire rated penetrations must be sealed with an approved firestop. However, the biggest problem for the building owner usually is in the form of gas or water migration into the structure or equipment. Some penetrations need to be protected against multiple hazards.

Roxtec provides complete penetration seals to protect against fire, water, gas, EMI/EMP, dust, rodents, explosion, etc.

Cable changes happen – plan for it

Future cable changes can be very costly without proper planning. Field-based decisions for routing new cables often lead to erratic cutting of cables or drilling of more

holes in walls and floors. The Roxtec modular design is an engineered, flexible solution with a “build as you grow” concept that allows cables to be changed or additional cables to be added later on – with minimal effort and cost.

FEATURES

- Fire rated
- Watertight
- Gastight
- Blast load protection
- Bonding and grounding
- EMC solutions
- Approved for hazardous locations

Certified protection

Roxtec solutions are certified by the world's major classification authorities. With 430 tests and approvals and 285 registered certificates, according to standards like UL 1479 and EN 1366, we are the leading manufacturer of modular-based cable and pipe penetration seals. We also provide certified solutions for Ex and EMC/EMI.



Our solutions have undergone hundreds of internal and officially registered fire and integrity tests showing their excellent performance and resistance to numerous hazards.

Qualified for any challenge

Designers can use Roxtec anywhere. The frames can be cast or welded into constructions, inserted in core-drilled holes or bolted onto the surface. The certificates qualify us to be specified in any construction project and allow our seals to play a critical safety role in a wide variety of projects and applications.

You can find more information in our Tests and Certificates brief and in our Product Database on www.roxtec.com.

CERTIFIED ACCORDING TO

- EN 1366-3 (European Norm)
- BS 476 (UK)
- DIN 4102-9 (Germany)
- UL 1479 (USA)
- GB 23864-2009, Chinese fire test standard
- The building standard law of Japan



Where to use Roxtec?

You find Roxtec cable and pipe seals in many applications throughout the construction industry. Discover the idea behind our innovative sealing solutions and learn how to apply Roxtec for applications in your projects. It is quick, safe and easy.

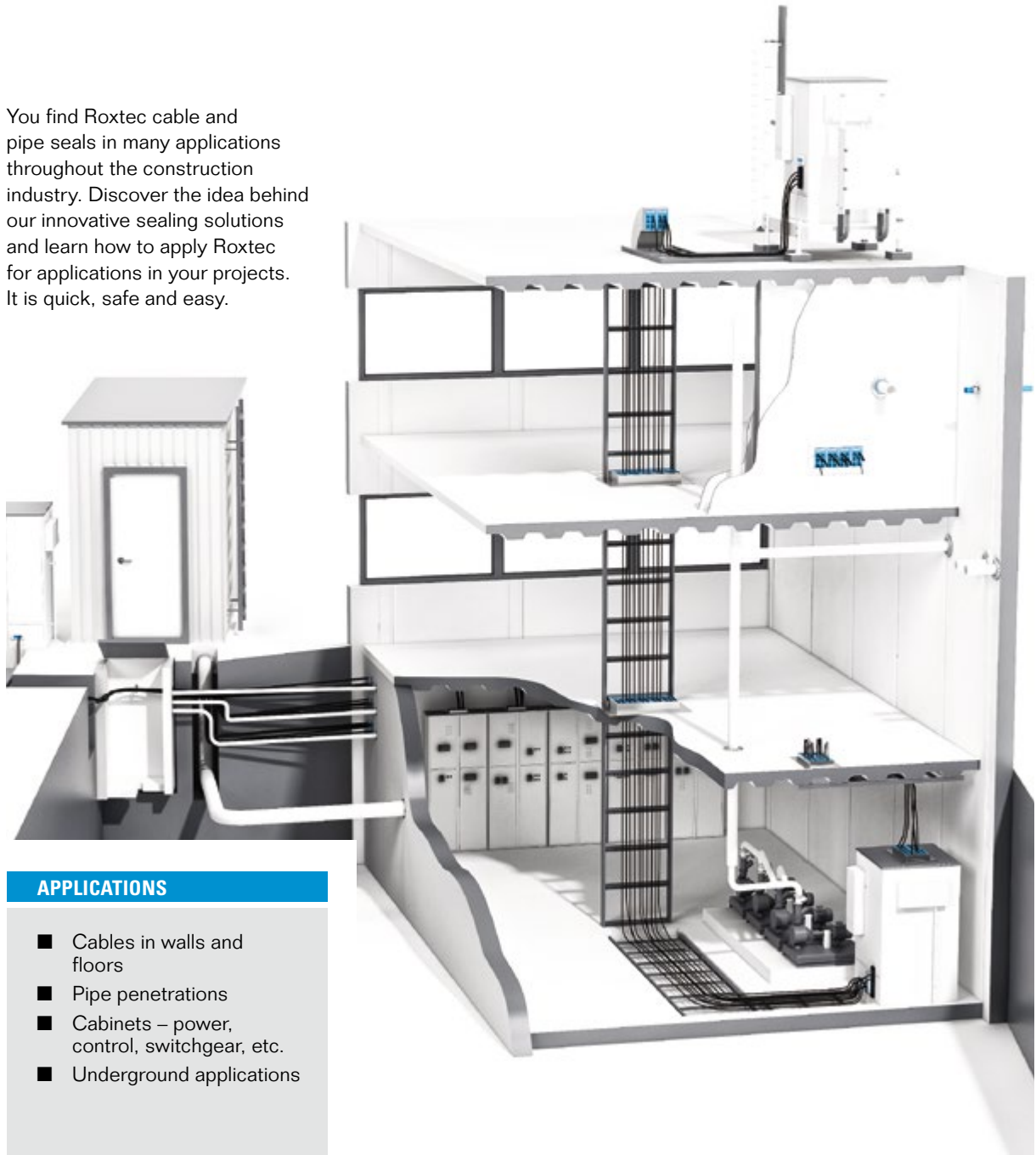

APPLICATIONS

- Cables in walls and floors
- Pipe penetrations
- Cabinets – power, control, switchgear, etc.
- Underground applications

Roxtec in walls and floors

Roxtec sealing systems are used in different types of wall penetrations and floor entries. If your project requires multiple cables and pipes through a wall or floor, and the structure must meet certain safety ratings, Roxtec is your one-source solution. The system requires less space than cable glands, simplifies design and installation, and provides spare capacity for expansion. You can seal most items that are required to penetrate walls or floors – cable, pipe, conduit and tubing.



► Roxtec frames can be bolted, welded or cast into a variety of building structures. The frames can be installed from the top or bottom side of the floor.

WALL TYPES

- Pre-fabricated/insulated
- Concrete
- Steel
- Gypsum board
- Block

FLOOR TYPES

- Steel (modular or prefabricated buildings)
- Raised (data and communication centers)
- Concrete (fixed location buildings)
- Containment (processing buildings)



Roxtec in round openings

Roxtec round transits are available for multiple as well as for single pipes. Our firestop solutions are easy to install and developed for various applications and materials. You can use them for plastic pipes, metal pipes and conduit, but also for cables.



► *Our round transits are developed for use in a wide range of demanding environments, and are ideal for area efficient sealing of wall or floor penetrations.*

COMMON APPLICATIONS

- Process piping and tubing
- Sprinkler systems
- Hydraulic and pneumatic lines
- Water supply and waste water lines
- Cables – power, instrumentation and control

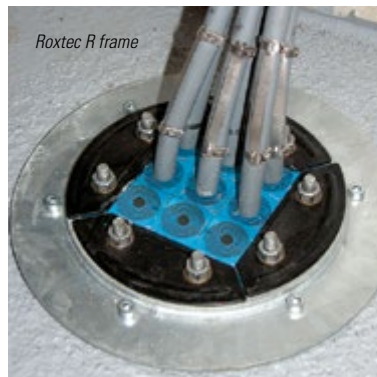

Roxtec R frame



Roxtec RS seal

Roxtec in cabinets and enclosures

You can use Roxtec multi-cable transits for control cabinets, junction boxes and other electrical and instrumentation enclosures. Roxtec solutions pay for themselves by allowing for high cable density which enables designers to reduce the size and weight of cabinets. The flexible solutions further reduce time and labor since they are ready for last minute changes. It is easy to add new or change cables in your power, control and switchgear cabinets. Roxtec secures, seals, and protects equipment in stainless steel, metal, plastic and composite enclosures.



▶ Thanks to the area efficiency and compact design of the Roxtec cabinet solutions, it is also possible to reduce the size of the cabinet.

COMMON APPLICATIONS

- DCS/PCS enclosures
- Electric heat trace cabinets
- Safety instrumented systems
- Fire and gas detection equipment cabinets
- Control cabinets
- Communication equipment enclosures



Roxtec CF 32 frame



Roxtec CF 32 frame

Roxtec in under-ground applications

Roxtec UG™ solutions are designed for underground applications where there is a need for sealing against constant water pressure. While other Roxtec seals also take care of the fire rating of your building structure, this product family is ideal for power cables entering via foundations.

The cable entry seals are specifically developed to be used in underground applications where fire is not an issue. The seals are designed to be resistant to constant as well as catastrophic water pressure. You can use them to eliminate flooding and prevent humidity from damaging equipment. The seals in the product family exist in different versions.

The openable Roxtec H3 UG seal, for example, is ready for direct routing of cables in trefoil formations, while the Roxtec C R UG and R UG frames are used with UG modules that are easy to adapt to cables and pipes of different sizes.



FEATURES

- Easy to design in and install
- Corrosion and rodent resistant
- Adapts to cables of different sizes
- Pull-out tests performed



Roxtec for electrical safety and hazardous areas

Roxtec provides complete solutions for bonding, grounding and electromagnetic compatibility, EMC, as well as for protection against the risk of explosion.

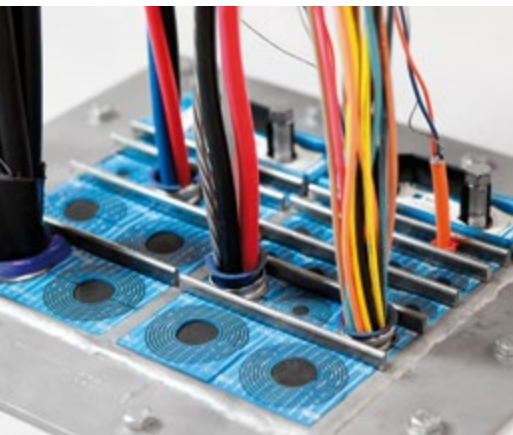

Roxtec EMC solutions can protect your equipment from electrical interference. The Roxtec BG™ (Bonding & Grounding) product family is a cable entry system for sealing, securing and grounding large quantities of metal clad or armored cables. Use it instead of cable glands in building structures, cabinets and enclosures to save 70% more space and to ensure a certified bonding or grounding termination.

For use in hazardous areas

The Roxtec Ex product family protects people, equipment and operations in hazardous locations, or potentially explosive atmospheres. Our products meet or exceed international requirements for hazardous locations around the world.

Approved for global electrical schemes

- IECEx
- ATEX
- CEC

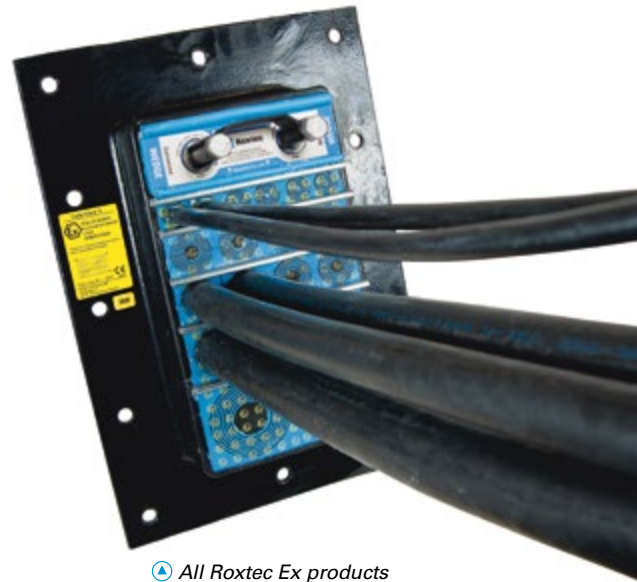

ⓘ All Roxtec Ex products are easily identified by the yellow Ex label.

CERTIFIED PROTECTION

- Fire rated, gas- and watertight
- Bonding and grounding
- Lightning protection
- Electromagnetic compatibility (EMC)
- Hazardous locations (Ex)

Roxtec in buildings and construction projects

Roxtec solutions are used in many environments and segments in the construction industry. The illustration shows where to use Roxtec seals to benefit from their flexibility and efficiency.



G frame in a cleanroom used to seal pipe penetrations.

GKO frame installed over a core-drilled hole. The GKO frame is ideal for retrofit solutions.

RS seals for single cables or pipes. Many sizes available.

RS seals in a manhole. For cables and pipes. Available in many sizes.

R frames with power cables in the basement of a building.



R frame installed in a core-drilled hole.

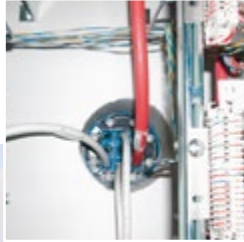

GKO frame installed over a core-drilled hole. The GKO frame is ideal for retrofit solutions.



G frame cast or bolted in walls and floors. G frames are available in multiple sizes and configurations.



Custom made solutions, any size and configuration is possible.



G frame used in a floor application to seal pipe penetrations.

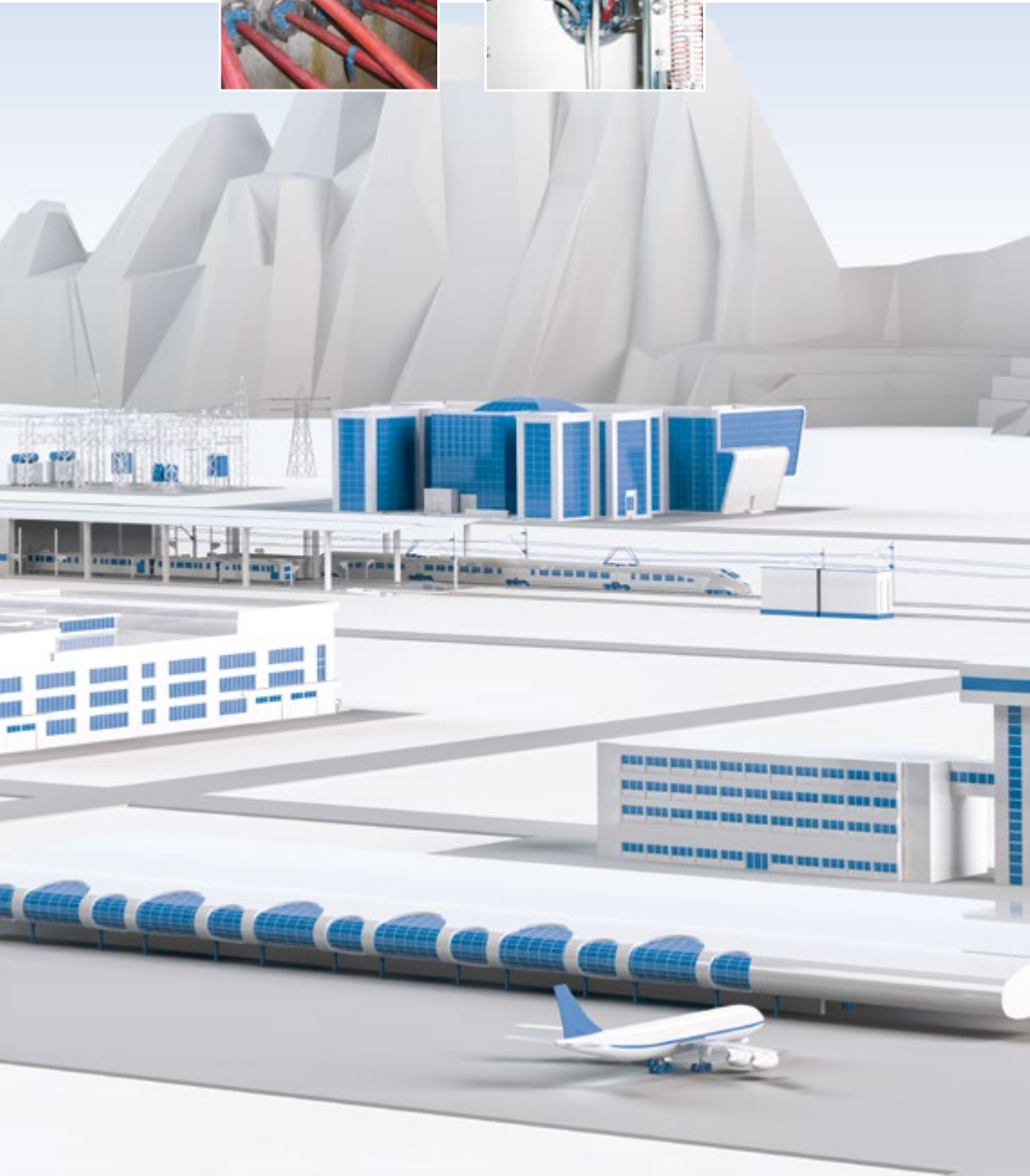

Roxtec Transit Designer™

The Roxtec Transit Designer allows auto-planning, drives project efficiency and reduces the risk of mistakes in all phases.

This web-based engineering tool is developed for design departments using Roxtec. It simplifies sealing product selection as well as the entire process of designing, purchasing and installing cable and pipe transits.

The Roxtec Transit Designer is accessible online. You can share your work with project teams anywhere in the world, and Roxtec transit design experts are always available through the chat function. To start using it, just register on www.roxtec.com.

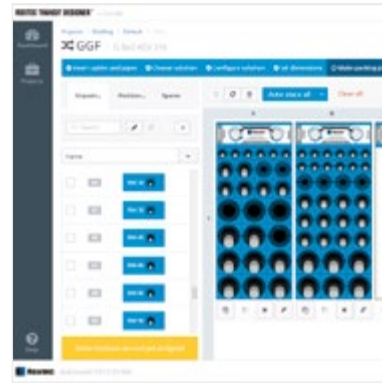

SIMPLE USER INPUT

Cable/pipe schedule or estimates
Sealing/certification requirements
Installation preferences

APPROVED OUTPUT

2D drawings in DXF and PDF
3D STEP
Bill of material in Excel
Installation instructions

FEATURES

- Free web-based application, available online
- Simple product selection
- Copy and paste for cable or pipe schedule inputs
- Manufacturer-approved engineering outputs
- Improves project efficiency and flexibility
- Reduces project risks

It is easy to specify Roxtec

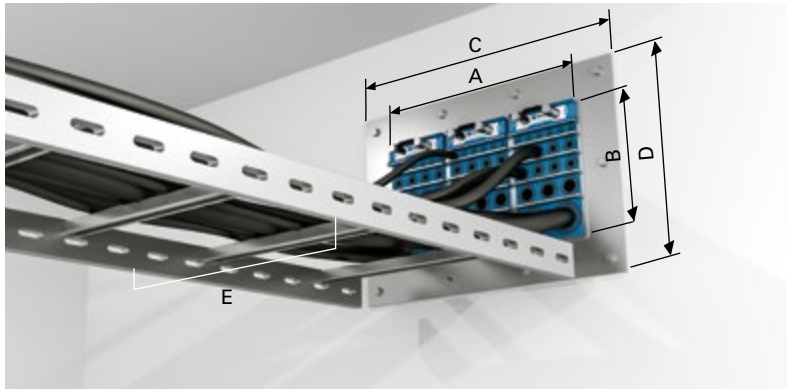

- ◀ A = Hole width
- B = Hole height
- C = Frame width
- D = Frame height
- E = Tray width

For quick reference, Roxtec frames can be chosen based on the size of the cable tray. This allows the frame dimensions to be specified or included in the project drawings. While this will give a quick reference for the project, we recommend using the Roxtec Transit Designer software or contacting your local Roxtec representative for complimentary designs and drawings.

Example

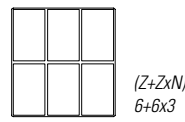
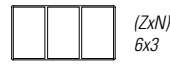

Z = Frame size
(6 = 218 mm, 8 = 278 mm)
N = Number of horizontal openings

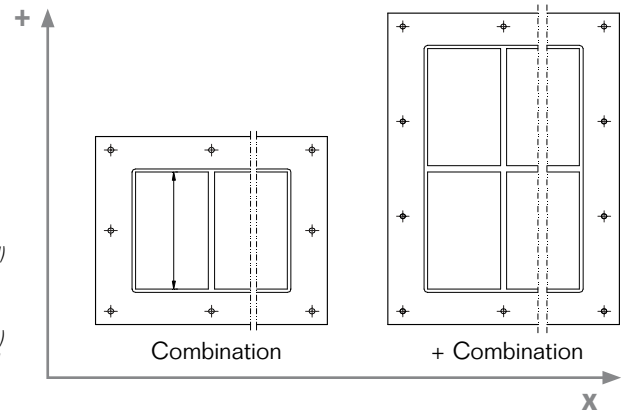

Tray/ladder mm/in (E)	Roxtec frame	Size (Z)	Wall opening size		Frame width	
			(A) mm/in	(B) mm/in	(C) mm/in	(D) mm/in
300/12	GH Zx2	6	278/10.945	245/9.646	463/18.228	430/16.929
		8	278/10.945	305/12.008	463/18.228	490/19.291
	GH Z+Zx2	6	278/10.945	475/18.700	463/18.228	580/22.346
		8	278/10.945	595/23.425	463/18.228	700/27.559
500/18	GH Zx3	6	409/16.102	245/9.646	593.5/23.366	430/16.929
		8	409/16.102	305/12.008	593.5/23.366	490/19.291
	GH Z+Zx3	6	409/16.102	475/18.700	593.5/23.366	580/22.346
		8	409/16.102	595/23.425	593.5/23.366	700/27.559
600/24	GH Zx4	6	539/21.220	245/9.646	724/28.504	430/16.929
		8	539/21.220	305/12.008	724/28.504	490/19.291
	GH Z+Zx4	6	539/21.220	475/18.700	724/28.504	580/22.346
		8	539/21.220	595/23.425	724/28.504	700/27.559
900/36	GH Zx7	6	930.5/36.634	245/9.646	1115.5/43.917	430/16.929
		8	930.5/36.634	305/12.008	1115.5/43.917	490/19.291
	GH Z+Zx7	6	930.5/36.634	475/18.700	1115.5/43.917	580/22.346
		8	930.5/36.634	595/23.425	1115.5/43.917	700/27.559

Multidiameter™ by Roxtec

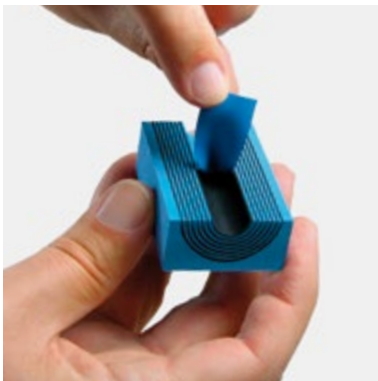

Our invention for adaptability to cables and pipes of different sizes is based on sealing modules and rubber bodies with removable layers. You just peel off layers to enable a perfect fit to any cable or pipe. This solution simplifies design, and saves a lot of installation labor time. It is also logistically efficient; you can drastically reduce the number of inventory items. In all, it makes electrical installations and maintenance work easy and safe.

Better space management

Thanks to the modular-based seal, cables are neatly organized. A small, but proper space between each cable creates area efficiency and facilitates inspection and maintenance. The flexibility – and the fact that your stock of seals is already onsite – allows you to modify the installation and add cables or pipes of different dimensions later on. Using Roxtec is a small investment in a million-

dollar construction, but it provides a lot of opportunities for meeting future regulations and for performing upgrades.

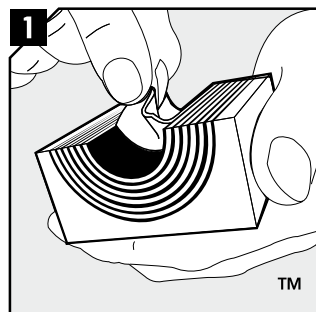
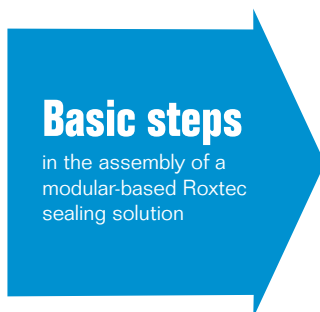

1 Adapt modules, which are to hold cables or pipes, by peeling off layers until you reach the gap seen in pic. 2. The halves may not differ by more than one layer.

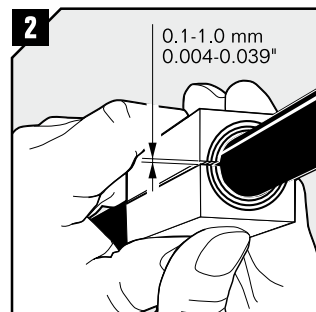

2 Achieve a 0.1-1.0 mm gap between the two halves when held against the cable/pipe.

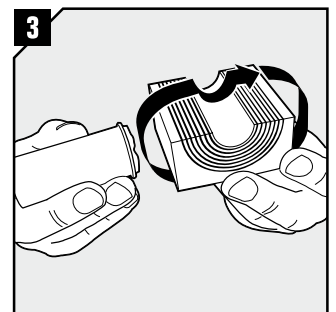

3 Lubricate all modules for the frame thoroughly, both the inside and the outside surfaces.

Easy installation with Roxtec



Installation training and tools

High safety standards require correctly installed and easily inspected products. On site installation training for local contractors and post-installation inspection are part of our full line of service. In addition to our on site training we have developed a range of practical tools to simplify quick and safe on site installations and reinstalls of Roxtec systems.

Include them in your specification and bill of materials.

- Reduce installation time and labor costs
- Ensure quality installation
- Engineered specifically for Roxtec products
- Online instruction videos available

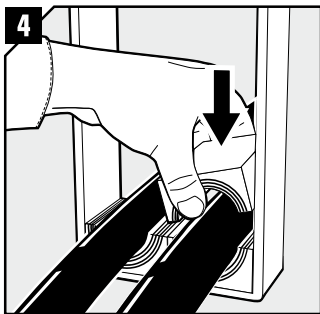

4 Insert the modules according to your installation plan (transit plan). It is recommended to seal cables/pipes at the bottom of the frame and put spare modules on top.

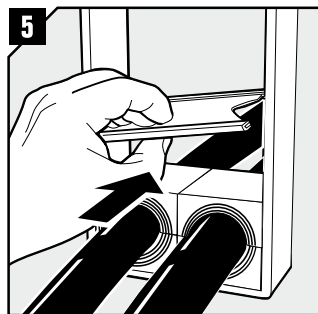

5 Insert a stayplate on top of every finished row of modules.

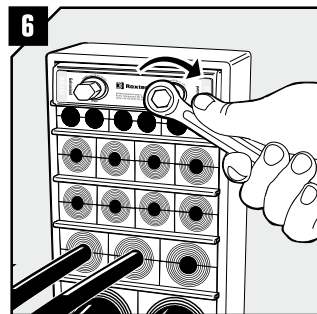

6 Insert the Roxtec Wedge and tighten the screws until full stop.

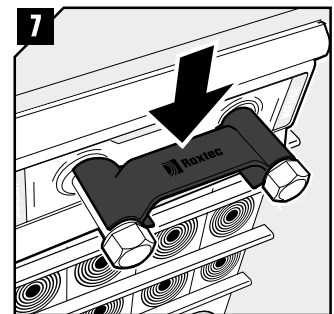

7 Attach the Wedge Clip to the wedge bolts to check that the wedge is properly tightened.

Minimize the total cost of ownership

Our solution is beneficial over time. It simplifies planning and design, speeds up installation and reduces the need for stock, material and logistics. It also helps maintenance teams upgrade and handle any surprise onsite regarding the dimension, number or material of cables or pipes.



A good reason for specifying Roxtec is the long-term cost-efficiency. Roxtec seals allow pre-terminated cables, which eliminate the need for cutting and re-attaching connectors. Other reinstatement features help users save time and money – such as the “future included” feature.

Ready for the future

Our seals offer optional built-in spare capacity for upgrades.



Whenever you need to add cables or pipes, the unused modules with Roxtec Multidiameter™ are ready. This solution is based on removable layers and allows for a perfect fit to any dimension of cable or pipe. It helps you stay really competitive, as you can add multiple cables or pipes – without adding any material costs.

Build today, upgrade tomorrow

The amount of spare capacity can be decided from the start. You can therefore design today for the needs of tomorrow, and just open up and reseal later on to benefit from the spare capacity. This constant readiness for changes is the unbeatable benefit of Roxtec. You save time, labor and maintenance costs, and achieve cost-efficiency through the entire lifecycle of the project. Roxtec provides long-term efficiency and helps you reduce the total cost of ownership.

First class services

Roxtec is not only an innovative product supported by an excellent product selection and design software. It is an entire supply concept.



We focus on providing solutions and on simplifying everything from planning through to logistics and installation. We offer design and pre-engineering services and develop, test and deliver customized solutions.

Kit solutions

We deliver kits designed to cover a wide range of cable configurations. The kit packages have one part number for easy standardization and ordering. We deliver from local stock, even directly to site. We listen to all your needs and help you find the optimal sealing solution.

Product installation training

Whenever you want, and wherever you operate, we provide product installation training through our sales staff and technicians. We are there to support and train you on site; just call us for more information. We provide a full range of product information. You find it all on our website: www.roxtec.com.



Customers and project references:

Areva, AstraZeneca, Aventis, Bank Stuttgart, BASF, Big Dig Boston, Cavanna S.p.A., Clinical Center Jena, CNOOC, ConocoPhillips, COVRA, Dow Chemical, Enercon, EWR, Gas District Woikoski, GlaxoSmithKline (GSK), INEOS Chemical, Main Station Berlin, Max-Planck-Institut, Merck, New York Times, Ontario Power Gen, Pfizer, Printing House Sanomala, Royal Alex Hospital, SECCO, SEI, St John's Waste Water Treatment Plant, ST Microelectronics, Winnipeg Int Airport.

Sweden, Roxtec International AB, HQ
Argentina, INGIAR Representaciones SRL
Australia, Roxtec Australia Ltd
Belgium, Roxtec b.v.b.a/s.p.r.l
Brazil, Roxtec Latin América Ltda
Chile, FACOR Ltda
China, Roxtec Sealing System (Shanghai) Co. Ltd
Croatia, Roxtec d.o.o.
Czech Republic, Roxtec CZ s.r.o
Denmark, Roxtec Denmark ApS
Finland, Roxtec Finland Oy
France, Roxtec France SAS
Germany, Roxtec GmbH
Hungary, Glob-Prot Trade and Service Ltd
India, Roxtec India Pvt Ltd
Israel, C&P Co. Ltd
Italy, Roxtec Italia S.r.l
Japan, Roxtec Japan K.K
Lithuania, SWELBALT UAB
Mexico, Roxtec de México, S.A. de C.V
Nigeria, Structured Resource Business Ltd
The Netherlands, Roxtec BV
Norway, Roxtec AS
Peru, Synixtor S.A.C
Poland, Pionet Sp.zo.o
Russia, Roxtec RU
Romania, Roxtec RO s.r.l.
Singapore/Indonesia, Roxtec Singapore PTE Ltd
South Africa, Roxtec Africa (PTY) Ltd
South Korea, Roxtec Korea Ltd
Spain, Roxtec Sistemas Pasamuros S.L
Switzerland, Agro AG
Turkey, Roxtec Yalıtım Çözümleri San. ve Tic. Ltd. Şti.
UAE, Roxtec Middle East F.Z.E
UK/Ireland, Roxtec Ltd,
USA/Canada, Roxtec Inc
Venezuela, Grupo ES Escorihuela Sornes, C.A

For other markets and detailed contact information, please visit www.roxtec.com



Roxtec International AB
Box 540, 371 23 Karlskrona, SWEDEN
PHONE +46 455 36 67 00, FAX +46 455 820 12
EMAIL info@roxtec.com, www.roxtec.com