

92W-1

Enclosed Electric Power Clamps | Smart Clamp | How to Order

92W-1 23 00 02 02

Clamp Arm Shaft	Shaft Length (L)
03	10 mm [0.39 in]
23	16 mm [0.63 in]

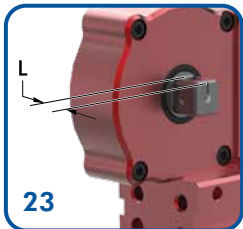
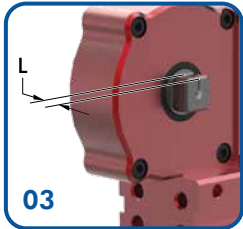

Body Style
 for 400 V Motor Option 01 only
 01 Compact Clamp Design
 for 48 V Motor Option 02 only
 02 Compact Clamp Design



Motor
 for Body Style Option 01 only
 01 Servo Drive, Decentral 400 V
 for Body Style Option 02 only
 02 Servo Drive, Decentral 48 V

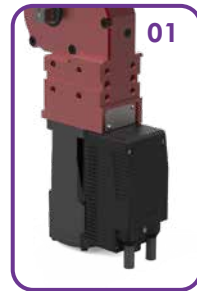

92W-123000101
 Shown with U-Arm
 8UM404-41-131
 (order separately)

92W-103000202
 Shown with U-Arm
 8UM404-41-131
 (order separately)

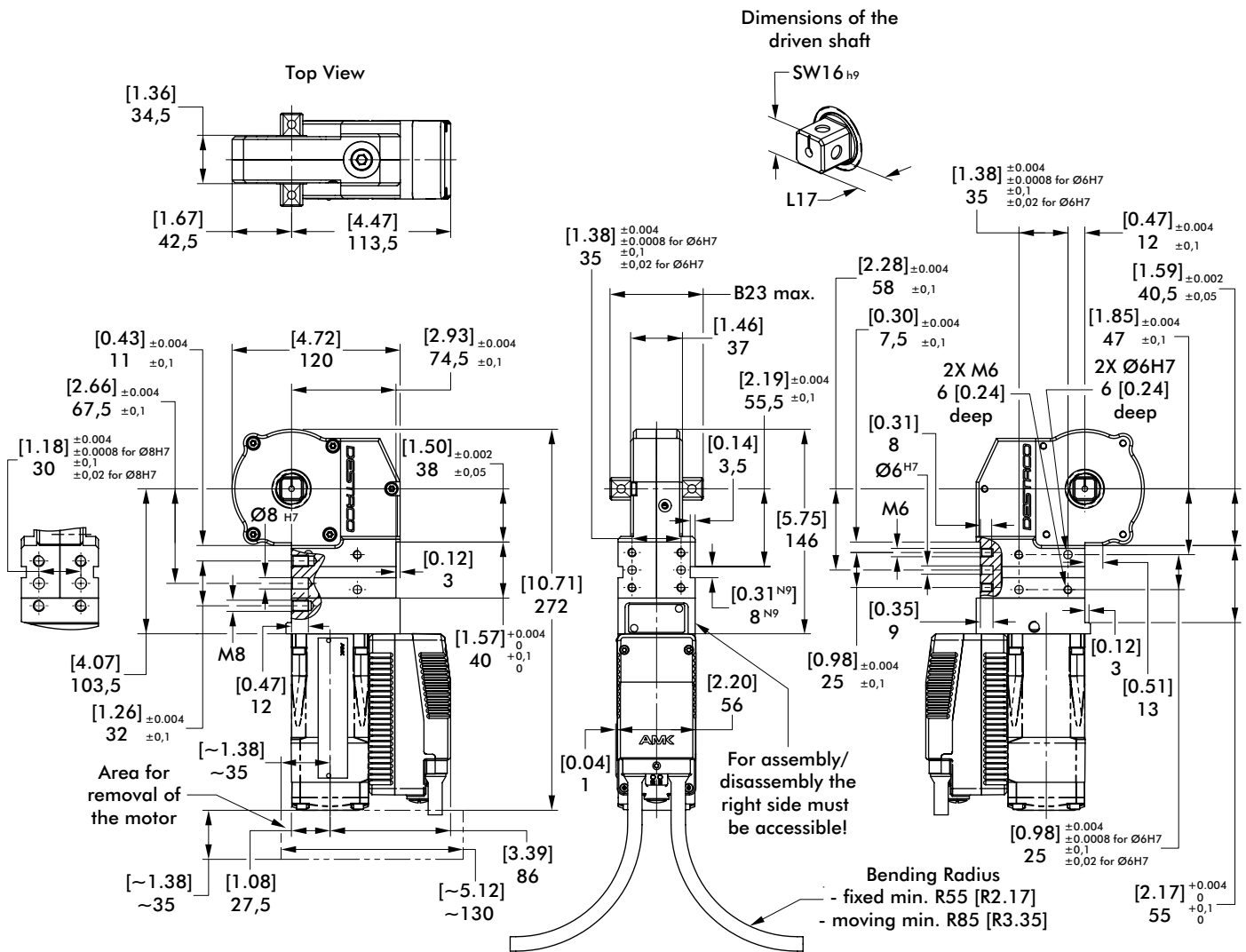

Area of Interference:
Keep this area free for assembly/disassembly work!

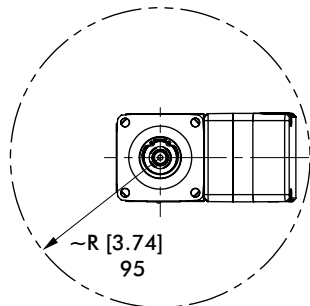

Model	Max. Holding Torque Nm [ft-lb]	Max. Clamping Torque Nm [ft-lb]	Weight kg [lbs]	B23 Max.	L17
92W-103000101	[332]	[7.4-74]	[7.72]	54,5 [2.15]	10 [0.39]
92W-123000101	450	10-100	3,5	66,5 [2.62]	16 [0.63]

92W-1....0202

Enclosed Electric Power Clamps | Smart Clamp | Dimensions | Technical Specifications

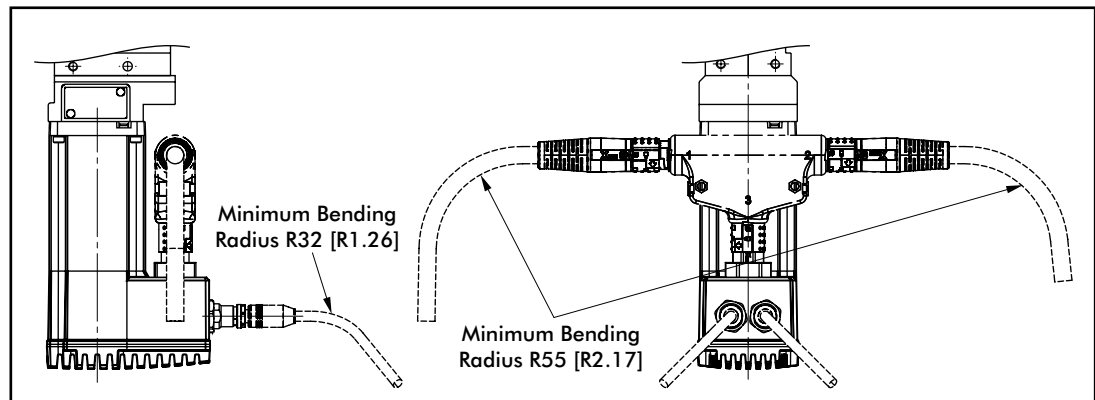
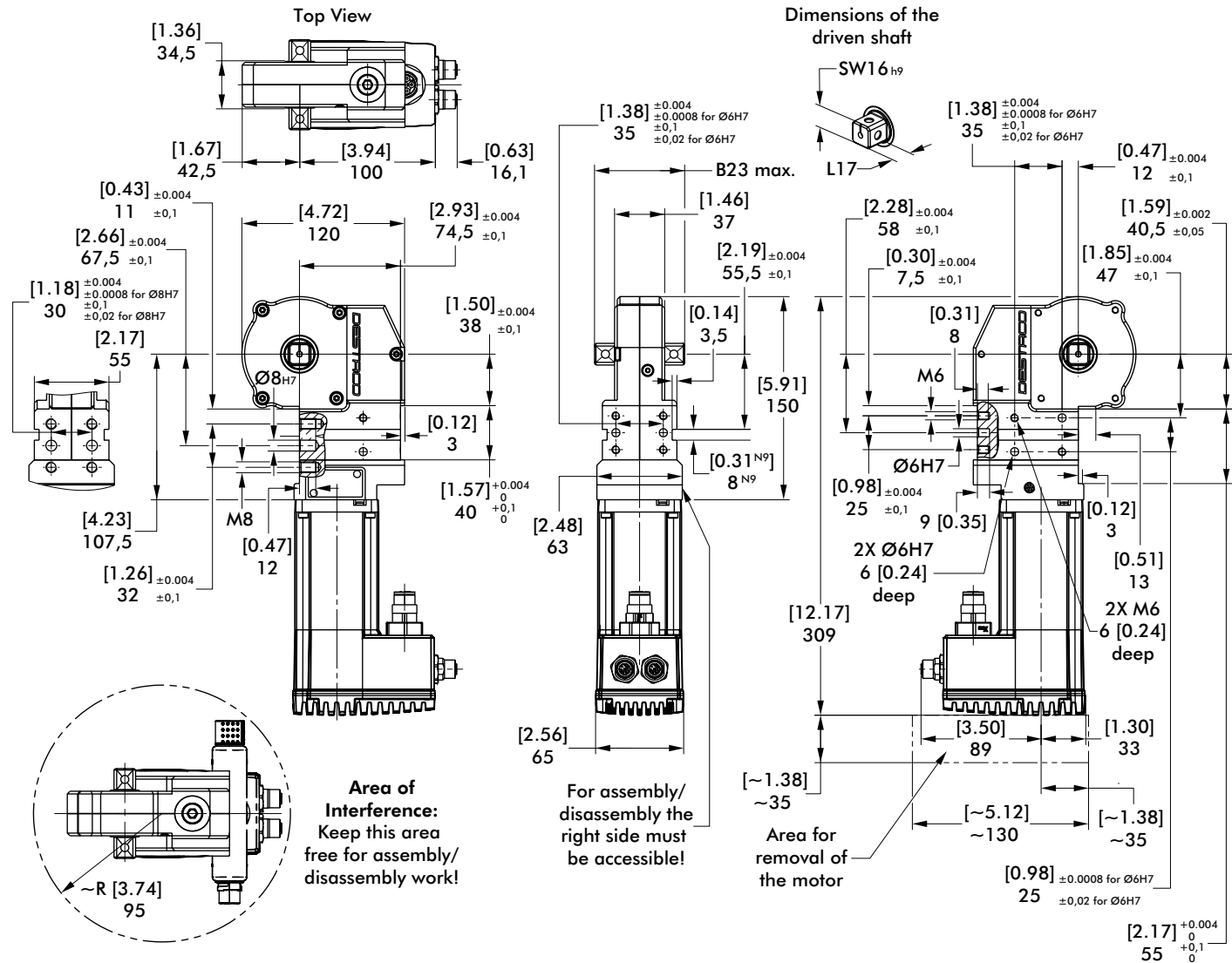

Model	Max. Holding Torque Nm [ft-lb]	Max. Clamping Torque Nm [ft-lb]	Weight kg [lbs]	B23 Max.	L17
92W-103000202	[332] 450	[7.4-89] 10-120	[7.93] 3,6	54,5 [2.15]	10 [0.39]
92W-123000202				66,5 [2.62]	16 [0.63]

Part Present Control and Tolerance Compensation

Distance (L) [in] mm	Part Thickness (X) Min. Tolerance (Tmin)* [in] mm	Tolerance Range [in] mm
[3.94 ±0.004] 100 ±0,1	[±0.0098] ±0,25	[0.019] 0,5
[5.91 ±0.004] 150 ±0,1	[±0.0138] ±0,35	[0.027] 0,7
[7.87 ±0.004] Max. 200 ±0,1 Max.	[±0.0177] ±0,45	[0.031] 0,9

*Specification only as a guideline

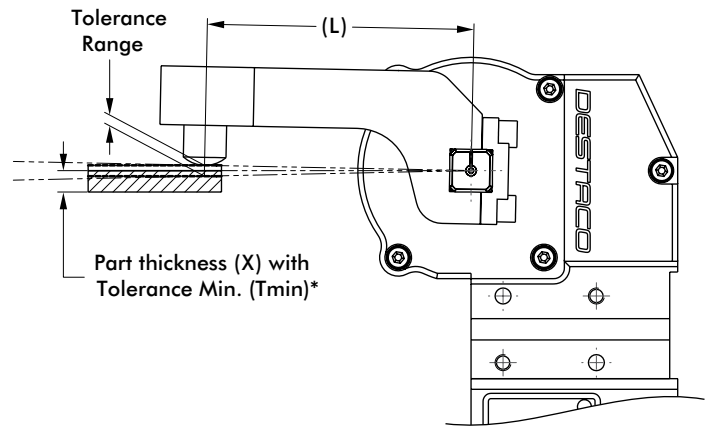

Technical Specifications

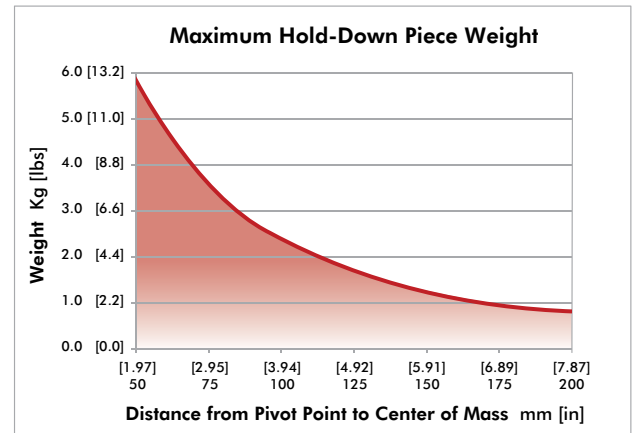
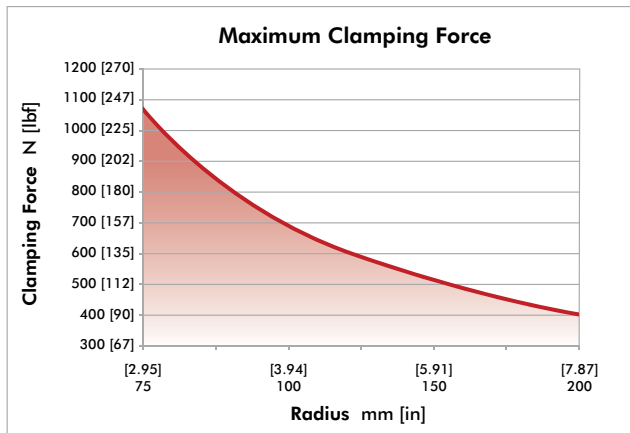

92W-1 U-ARMS CENTER (ALUMINUM)

Enclosed Electric Power Clamps | Dimensions | Technical Specifications

U-Clamp Arm, Center

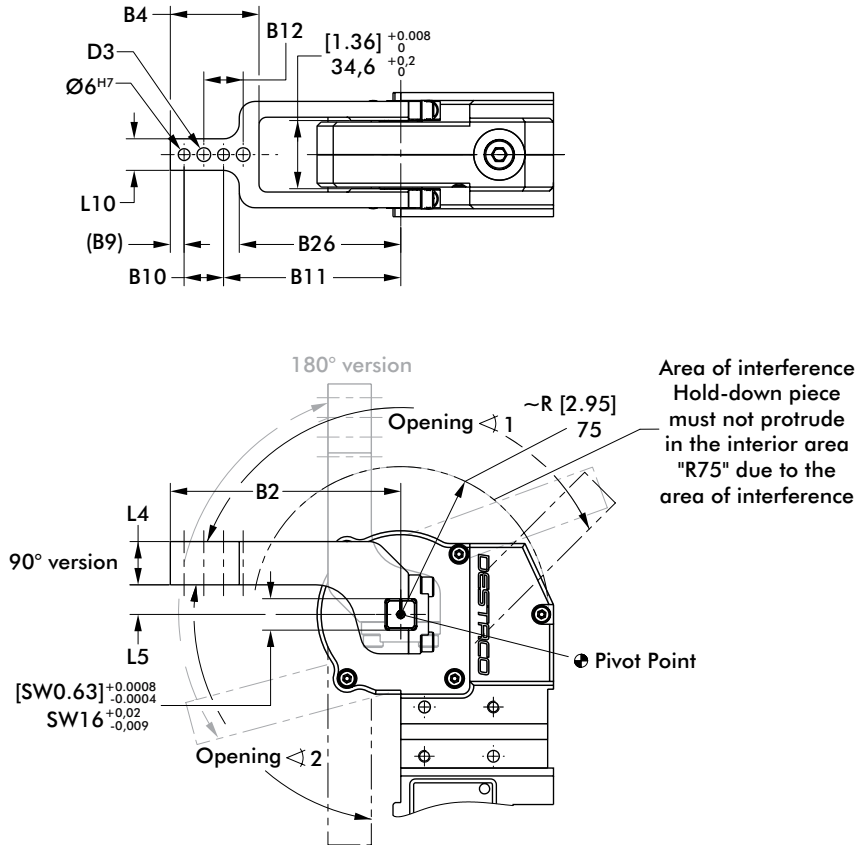

- 8UM404-00-117
- 8UM404E-15-117
- 8UM404E-15-144
- 8UM404E-25-117
- 8UM404E-45-107
- 8UM404-41-131

Arm Model No.	Max. Opening Angle for 90° Version		Max. Opening Angle for 180° Version		Weight kg [lbs]	B2	B4	B9	B10	B11	B12	B26	D3	L4	L5	L10
	$\sphericalangle 1$	$\sphericalangle 2$	$\sphericalangle 1$	$\sphericalangle 2$		$[\pm 0.0008]$ $\pm 0,02$	$[\pm 0.004]$ $\pm 0,1$	$[\pm 0.008]$ $\pm 0,2$						$[\pm 0.004]$ $\pm 0,1$		
8UM404-00-117	135°	85°	55°	140°	[0.49] 0,22	[4.61] 117	[1.77] 45	[0.28] 7	[0.79] 20	[3.54] 90	[0.79] 20		[0.28] 7	[0.87] 22	0	[0.63] 16
8UM404E-15-117		70°	105°	[0.51] 0,23	[5.67] 144	[2.83] 72	[0.35] 9	[1.18] 30	[4.13] 105	[1.18] 30	[3.23] 82	[0.35] 9	[1.10] 28	[0.59] 15	[0.79] 20	
8UM404E-15-144		90°	90°	100°	[0.73] 0,33	[4.61] 117	[1.77] 45	[0.28] 7	[0.79] 20	[3.54] 90	[0.79] 20		[0.28] 7		[0.98] 25	[0.63] 16
8UM404E-25-117		130°	110°	95°	[0.53] 0,24	[4.21] 107	[1.77] 45	[0.28] 7	[0.79] 20	[3.15] 80	[0.79] 20	[2.83] 72	[0.28] 7	[0.87] 22	[1.77] 45	[0.63] 16
8UM404E-45-107		90°	90°	100°	[0.64] 0,29	[5.16] 131	[2.64] 67	[0.35] 9	[1.18] 30	[3.62] 92	[1.18] 30	[3.03] 77	[0.35] 9		[1.61] 41	[0.79] 20
8UM404-41-131		135°	105°	95°												

Dimensions = [in] mm

92W-1 U-ARMS OFFSET (ALUMINUM)

Enclosed Electric Power Clamps | Dimensions | Technical Specifications

U-Clamp Arm, Offset

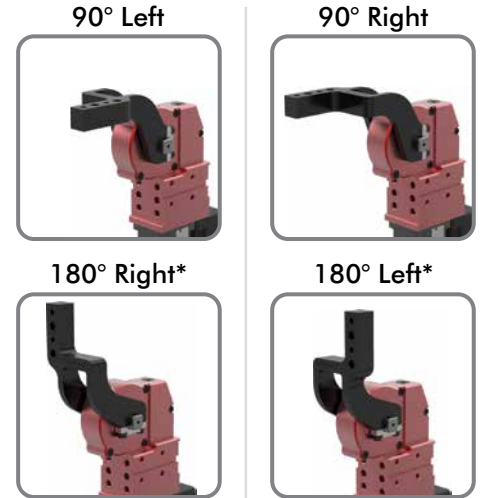
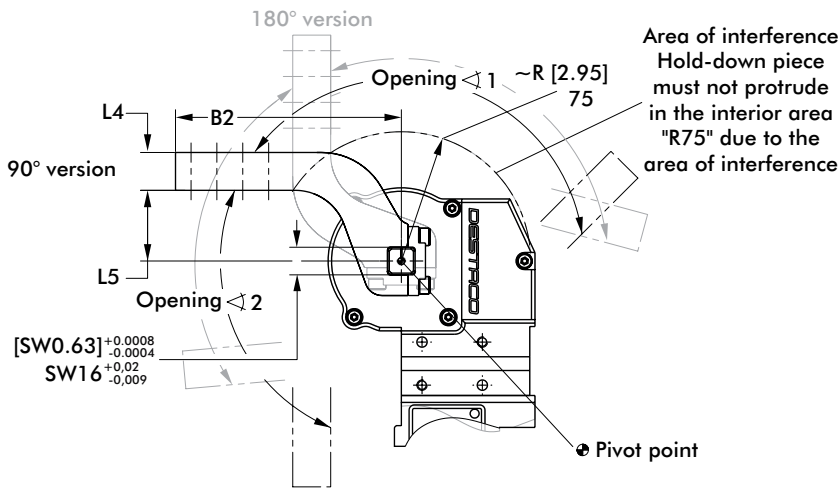
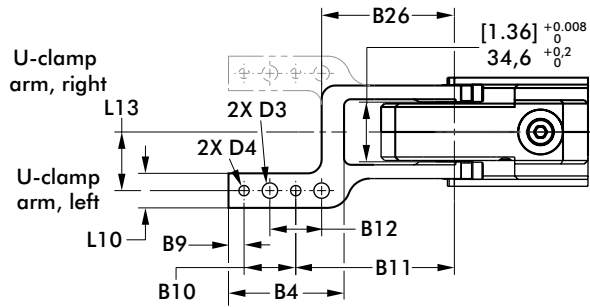

- | | |
|----------------|----------------|
| 8UL404-00-117 | 8UR404-00-117 |
| 8UL404E-15-117 | 8UR404E-15-117 |
| 8UL404E-25-117 | 8UR404E-25-117 |
| 8UL404E-45-107 | 8UR404E-45-107 |
| 8UL404E-15-144 | 8UR404E-15-144 |
| 8UL404-41-131 | 8UR404-41-131 |

*90° left/180° right uses same clamp arm.
90° right/180° left uses same clamp arm.

Arm Model No. Left 90° / Right 180°	Arm Model No. Right 90° / Left 180°	Max. Opening Angle for 90° Version		Max. Opening Angle for 180° Version		Weight kg [lbs]
		$\sphericalangle 1$	$\sphericalangle 2$	$\sphericalangle 1$	$\sphericalangle 2$	
8UL404-00-117	8UR404-00-117	135°	85°	55°	140°	0,22 [0.49]
8UL404E-15-117	8UR404E-15-117		70°	105°	0,23 [0.51]	
8UL404E-25-117	8UR404E-25-117		90°	100°	0,24 [0.53]	
8UL404E-45-107	8UR404E-45-107		70°	105°	0,35 [0.77]	
8UL404E-15-144	8UR404E-15-144		105°	95°	0,30 [0.66]	
8UL404-41-131	8UR404-41-131					

Arm Model No. Left 90° / Right 180°	Arm Model No. Right 90° / Left 180°	B2	B4	B9	B10	B11	B12	B26	L4	L5	\varnothing D3	\varnothing D4	L10	L13
					[±0.0008] ±0,02	[±0.004] ±0,1	[±0.008] ±0,2		[±0.004] ±0,1			H7		[±0.004] ±0,1
8UL404-00-117	8UR404-00-117									0				
8UL404E-15-117	8UR404E-15-117	[4.61] 117	[1.77] 45	[0.28] 7	[0.79] 20	[3.54] 90	[0.79] 20	[3.23] 82	[0.87] 22	[0.59] 15	[0.28] 7		[0.63] 16	[0.91] 23
8UL404E-25-117	8UR404E-25-117									[0.98] 25				
8UL404E-45-107	8UR404E-45-107	[4.21] 107				[3.15] 80		[2.83] 72		[1.77] 45	[0.24] 6			
8UL404E-15-144	8UR404E-15-144	[5.67] 144	[2.83] 72		[1.18] 30	[4.13] 105	[1.18] 30	[3.23] 82	[1.10] 28	[0.59] 15			[0.79] 20	[1.46] 37
8UL404-41-131	8UR404-41-131	[5.16] 131	[2.64] 67	[0.35] 9		[3.62] 92		[3.03] 77	[0.87] 22	[1.61] 41	[0.35] 9			[1.34] 34

Dimensions = [in] mm

92W-1 H-ARMS (ALUMINUM)

Enclosed Electric Power Clamps | Dimensions | Technical Specifications

H-Clamp Arms

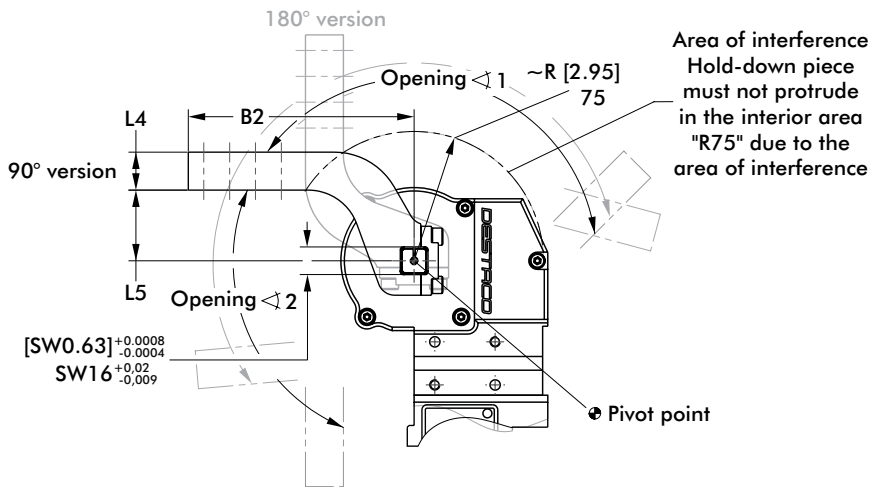
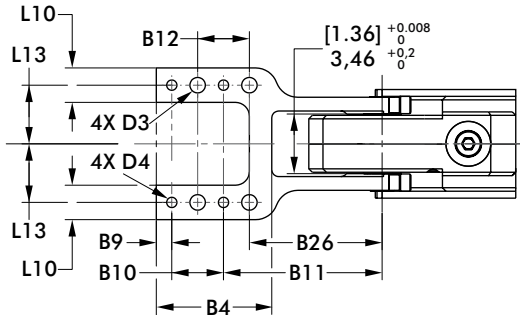

8UH404E-15-117
8UH404E-15-144
8UH404-41-131

Arm Model No.	Max. Opening Angle for 90° Version		Max. Opening Angle for 180° Version		Weight kg [lbs]
	$\sphericalangle 1$	$\sphericalangle 2$	$\sphericalangle 1$	$\sphericalangle 2$	
8UH404E-15-117			70°	105°	[0.57] 0,26
8UH404E-15-144	135°	90°			[1.01] 0,46
8UH404-41-131			105°	95°	[0.82] 0,37

Arm Model No.	B2	B4	B9	B10 <small>±0.0008 ±0,02</small>	B11 <small>±0.004 ±0,1</small>	B12 <small>±0.008 ±0,2</small>	B26	L4 <small>±0.004 ±0,1</small>	L5	D3	D4 H7	L10	L13 <small>±0.004 ±0,1</small>
8UH404E-15-117	[4.61] 117	[1.77] 45	[0.28] 7	[0.79] 20	[3.54] 90	[0.79] 20	[3.23] 82	[0.87] 22	[0.59] 15	[0.28] 7		[0.63] 16	[0.91] 23
8UH404E-15-144	[5.67] 144	[2.83] 72	[0.35] 9	[1.18] 30	[4.13] 105	[1.18] 30		[1.10] 28		[0.35] 9	[0.24] 6	[0.79] 20	[1.46] 37
8UH404-41-131	[5.16] 131	[2.64] 67			[3.62] 92		[3.03] 77	[0.87] 22	[1.61] 41				[1.34] 34

Dimensions = [in] mm

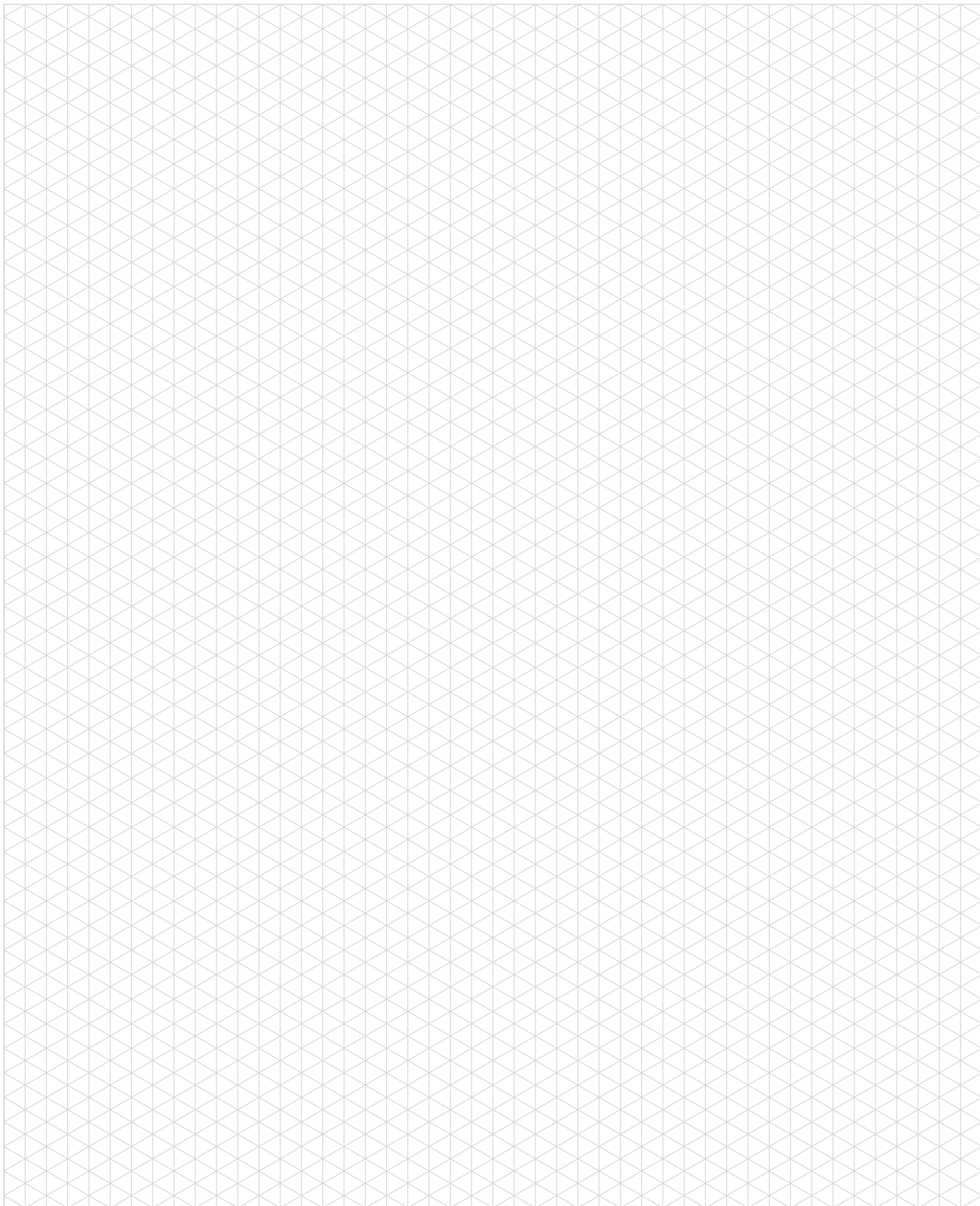

95W-1

Electric Slide | Smart Slide | How to Order

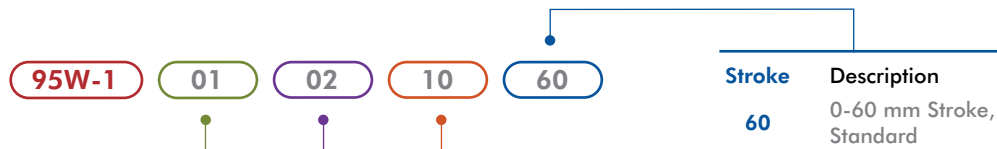

Motor Connection	Description
00	Straight, without Drive
01	Straight, Rear Connections
02	Straight, Connections on Right
03	Straight, Connections on Left
10	Redirected, without Drive
11	Redirected, Rear Connections
12	Redirected, Connections on Right
13	Redirected, Connections on Left

Motor	Description
01	Servo Drive, Decentral 400 V
02	Servo Drive, Decentral 48 V

Stroke	Description
60	0-60 mm Stroke, Standard

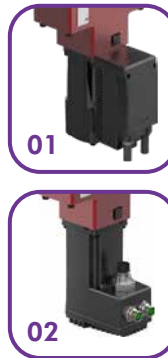
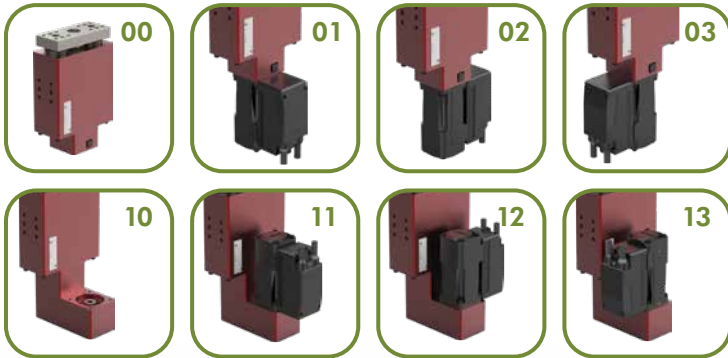
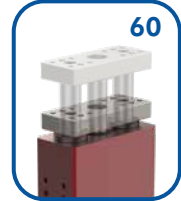

Mounting Plate	Description
10	Mounting Plate, Standard

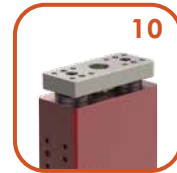

95W-111021060

95W-101011060

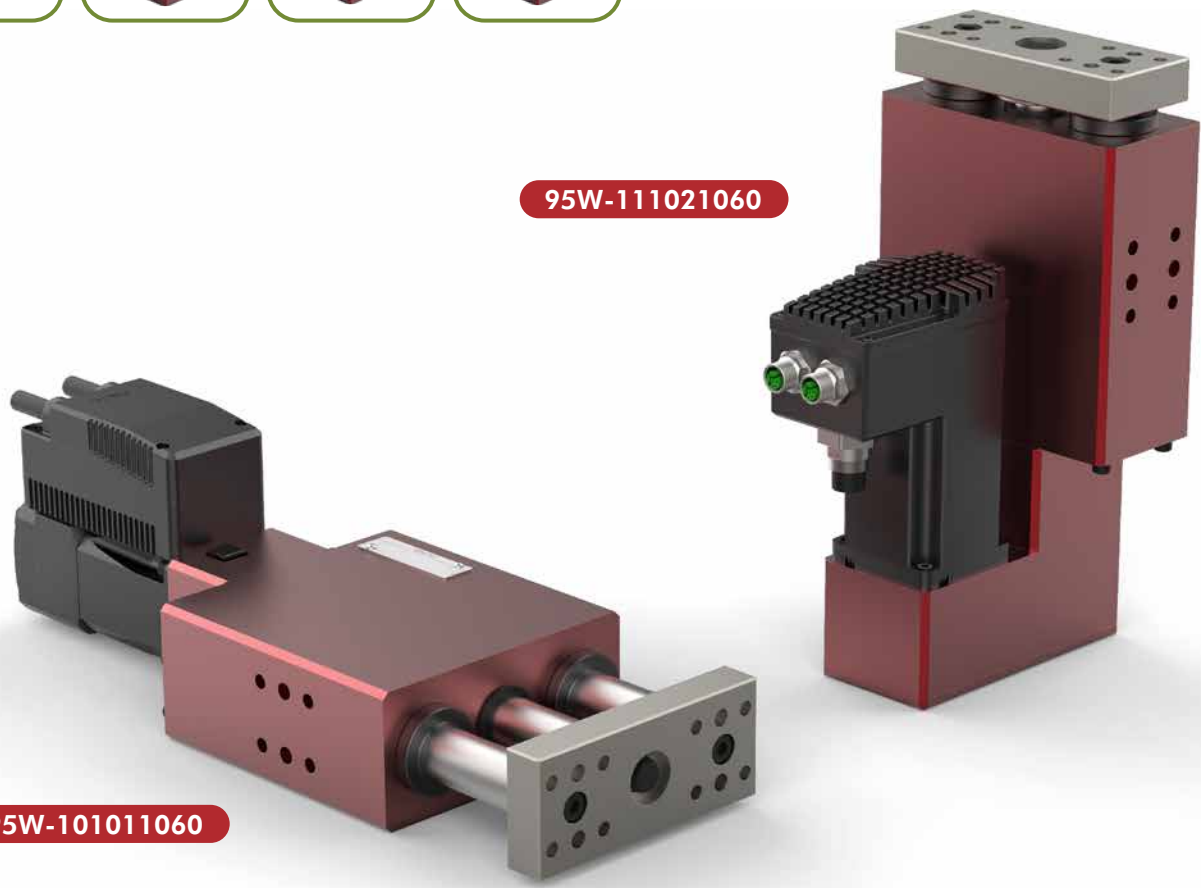

95W-10.011060

Electric Slide | Smart Slide | Dimensions | Technical Specifications

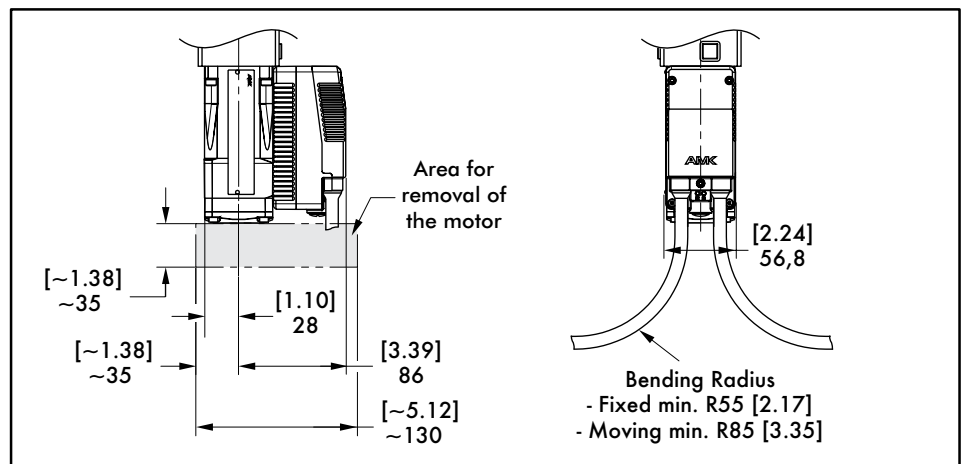
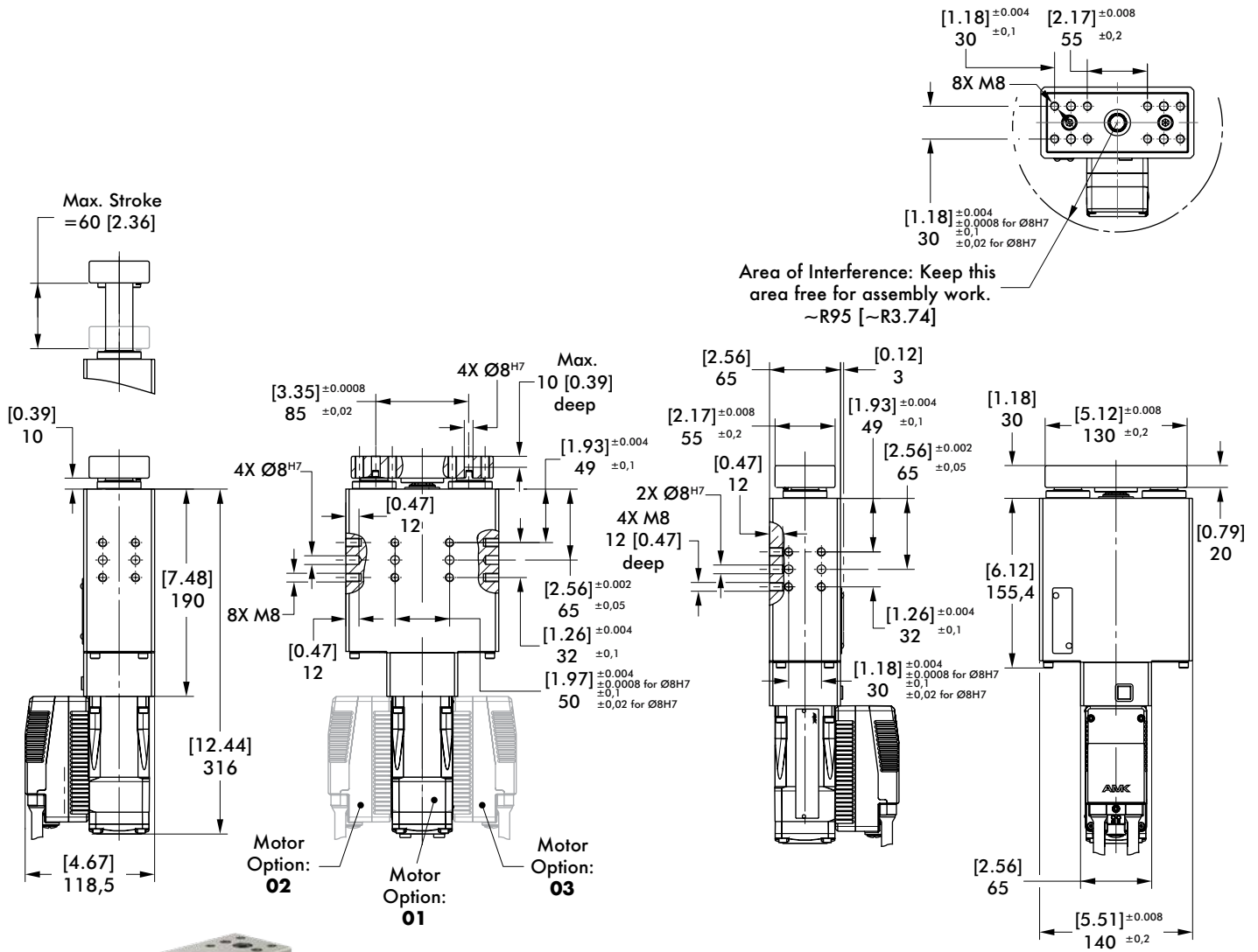

Base Model	Stroke mm [in]	Thrust Force N [lbf]	Retraction Force N [lbf]	Speed Max. mm/s [in/s]	Weight Kg [lbs]
95W-10.011060	[0-2.36] 0-60	[225] 1000	[225] 1000	[2.36] 60	[16.09] 7,3

95W-11.021060

Electric Slide | Smart Slide | Dimensions | Technical Specifications

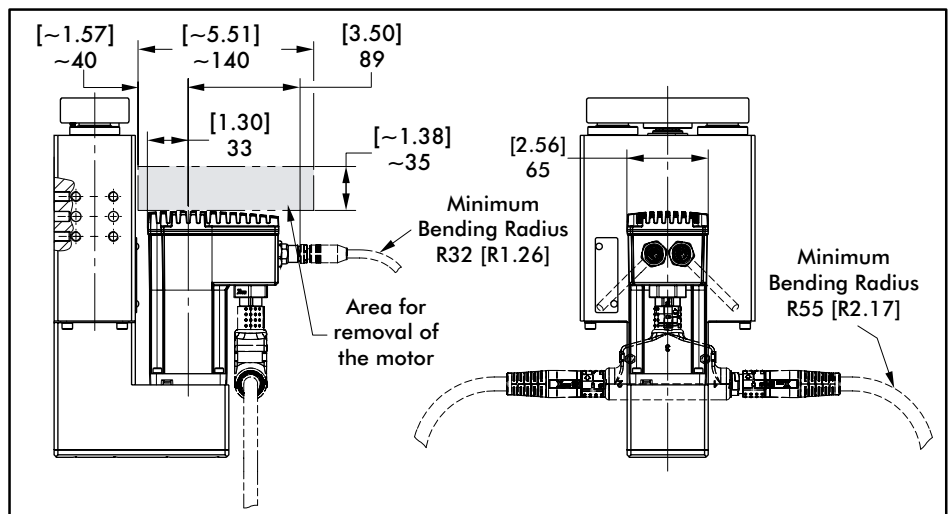
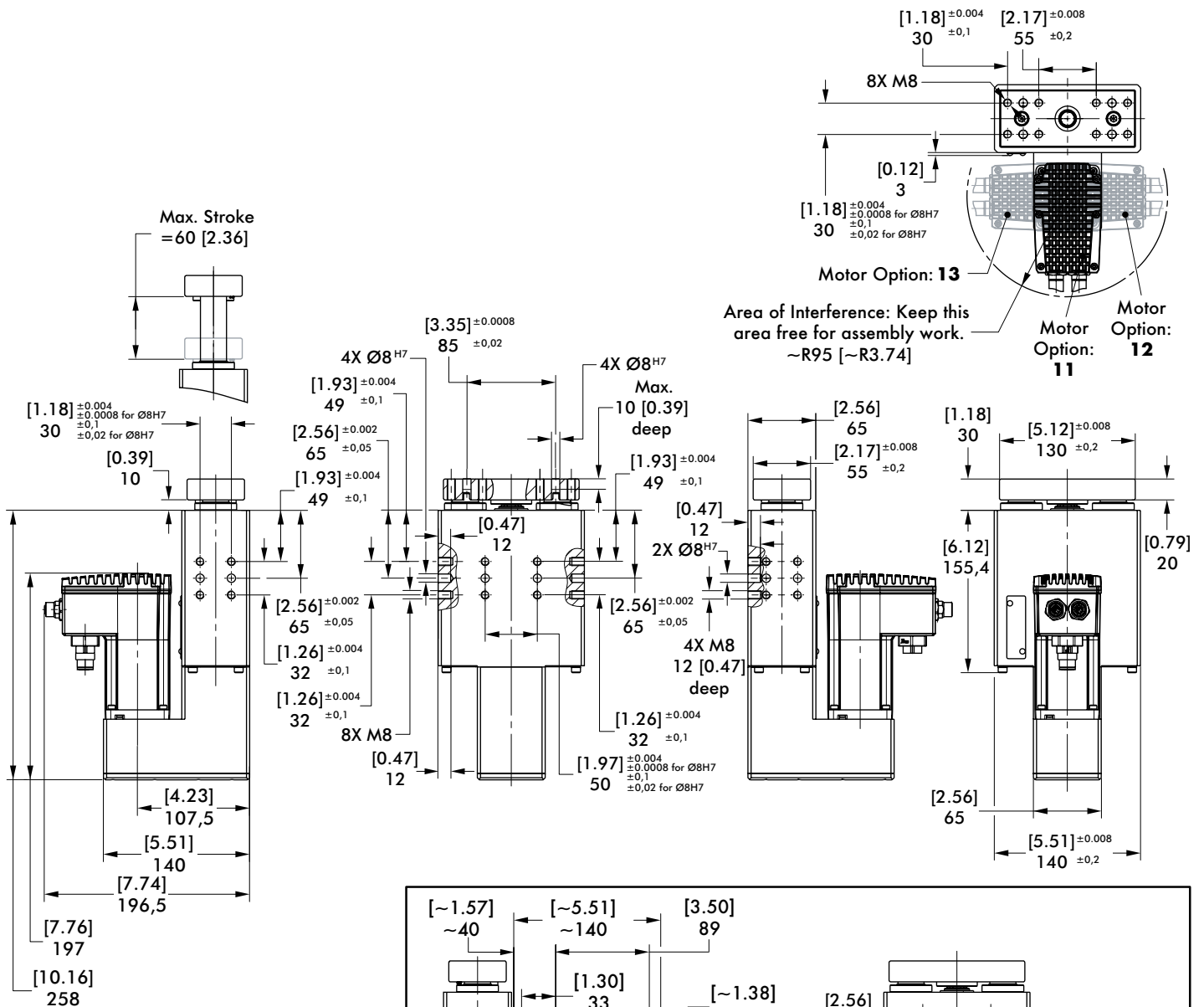

Base Model	Stroke mm [in]	Thrust Force N [lbf]	Retraction Force N [lbf]	Speed Max. mm/s [in/s]	Weight Kg [lbs]
95W-11.021060	[0-2.36] 0-60	[225] 1000	[225] 1000	[2.36] 60	[19.84] 9,0



96W-1

Electric Pin Package | Smart Pin Package | How to Order

96W-1 **01** **02** **A4** **60**

Motor Connection	Description
00	Straight, without Drive
01	Straight, Rear Connections
02	Straight, Connections on Right
03	Straight, Connections on Left
10	Redirected, without Drive
11	Redirected, Rear Connections
12	Redirected, Connections on Right
13	Redirected, Connections on Left

Motor	Description
01	Servo Drive, Decentral 400 V
02	Servo Drive, Decentral 48 V

Stroke	Description
60	0-60 mm Stroke, Standard

Piston Rod

Description	
02	Ø16 mm M6 Threaded Inside Hole, Cross Groove
04	NAAMS Standard
A4	NAAMS Standard Rotated 180°
B4	NAAMS Standard Rotated 90°
C4	NAAMS Standard Rotated 270°
05	Ø10 mm Inside Hole, Cross Groove

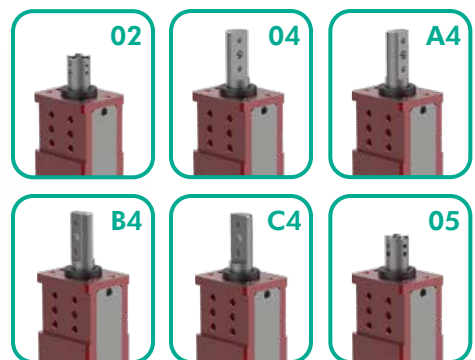
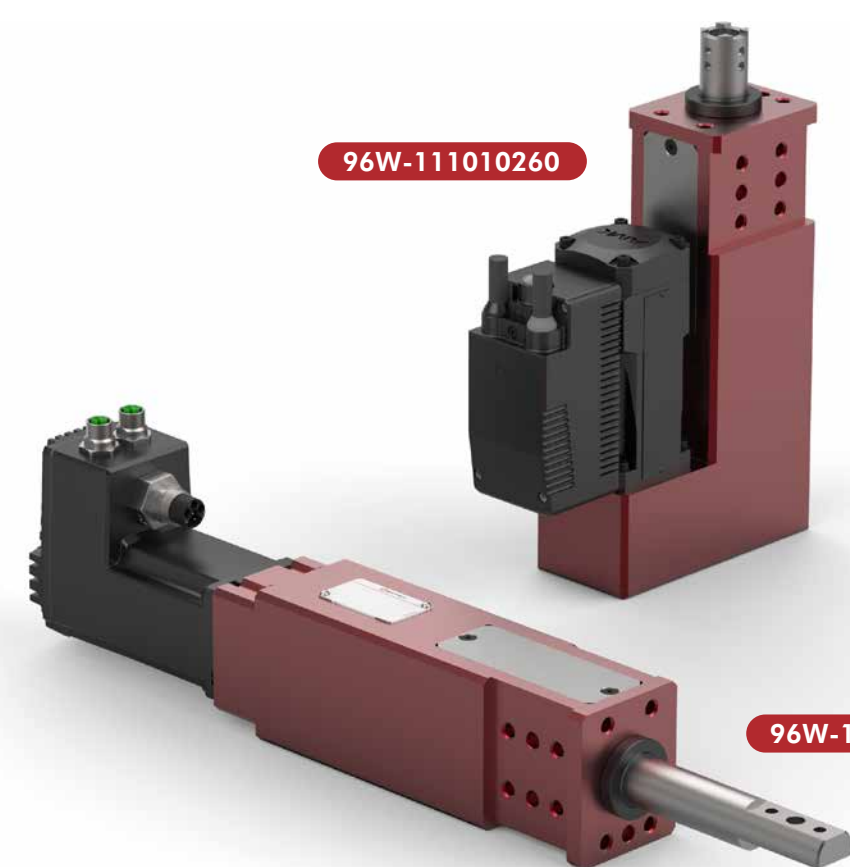

96W-10.02..60

Electric Pin Package | Smart Pin Package | Dimensions | Technical Specifications

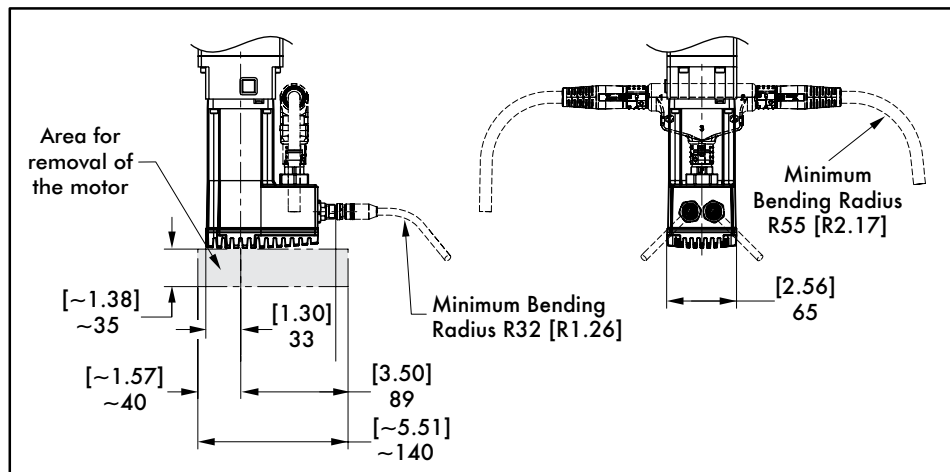
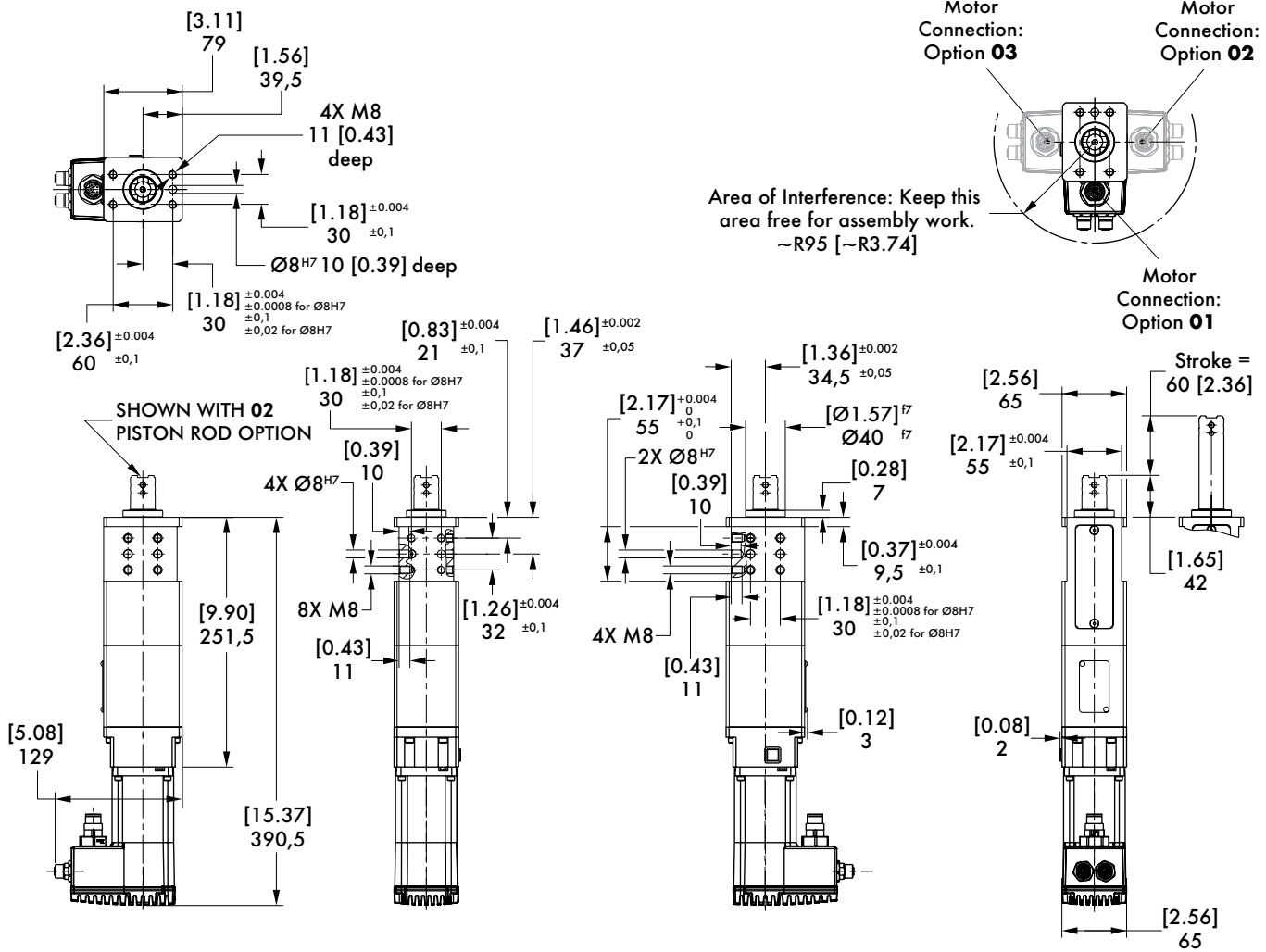

Base Model	Stroke mm [in]	Thrust Force N [lbf]	Retraction Force N [lbf]	Speed Max. mm/s [in/s]	Weight Kg [lbs]
96W-10.02..60	[0-2.36] 0-60	[225] 1000	[225] 1000	[2.36] 60	[11.90] 5,4

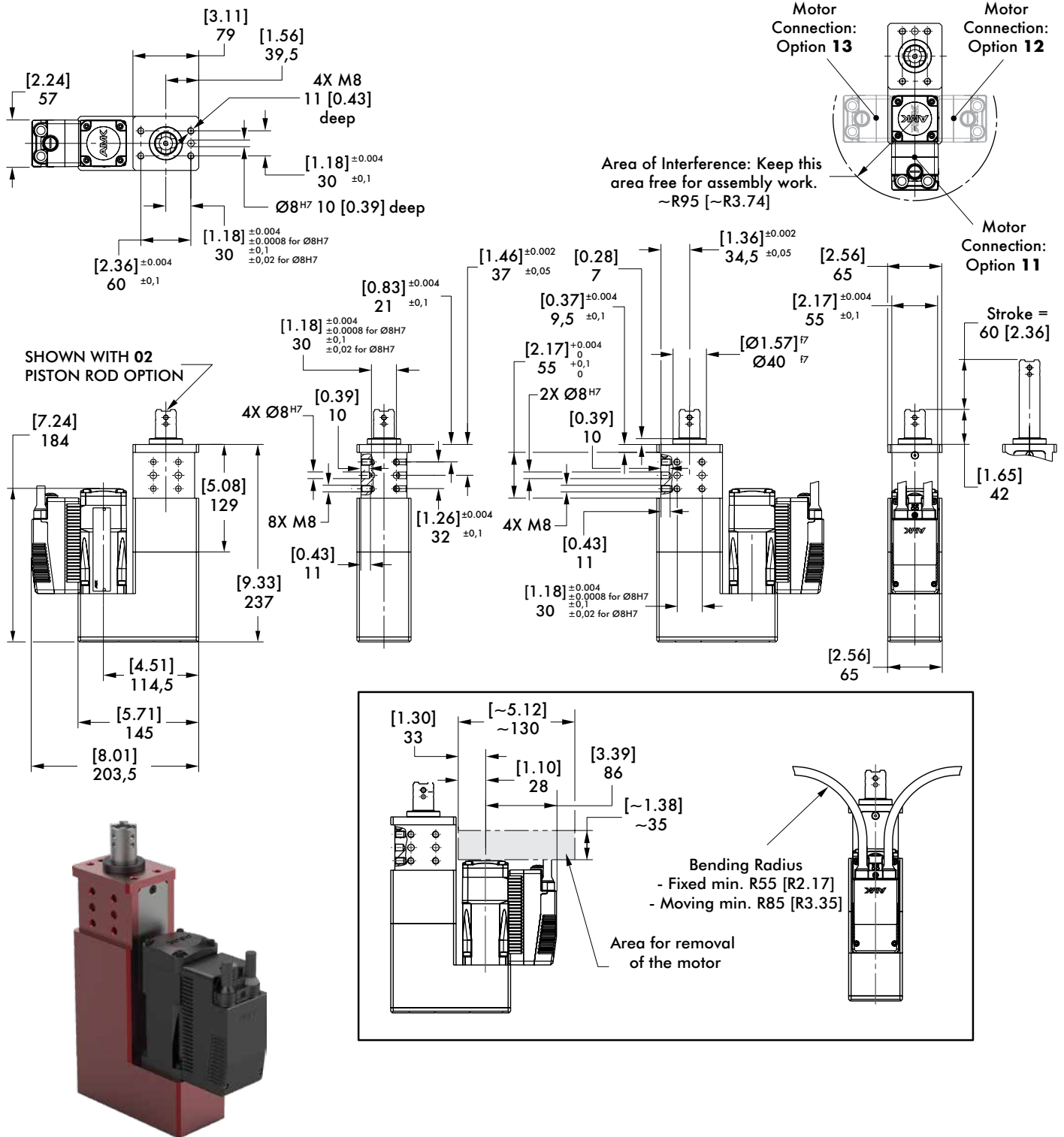

Base Model	Stroke mm [in]	Thrust Force N [lbf]	Retraction Force N [lbf]	Speed Max. mm/s [in/s]	Weight Kg [lbs]
96W-11.01..60	[0-2.36] 0-60	[225] 1000	[225] 1000	[2.36] 60	[13.23] 6,0

96W-11.02..60

Electric Pin Package | Smart Pin Package | Dimensions | Technical Specifications

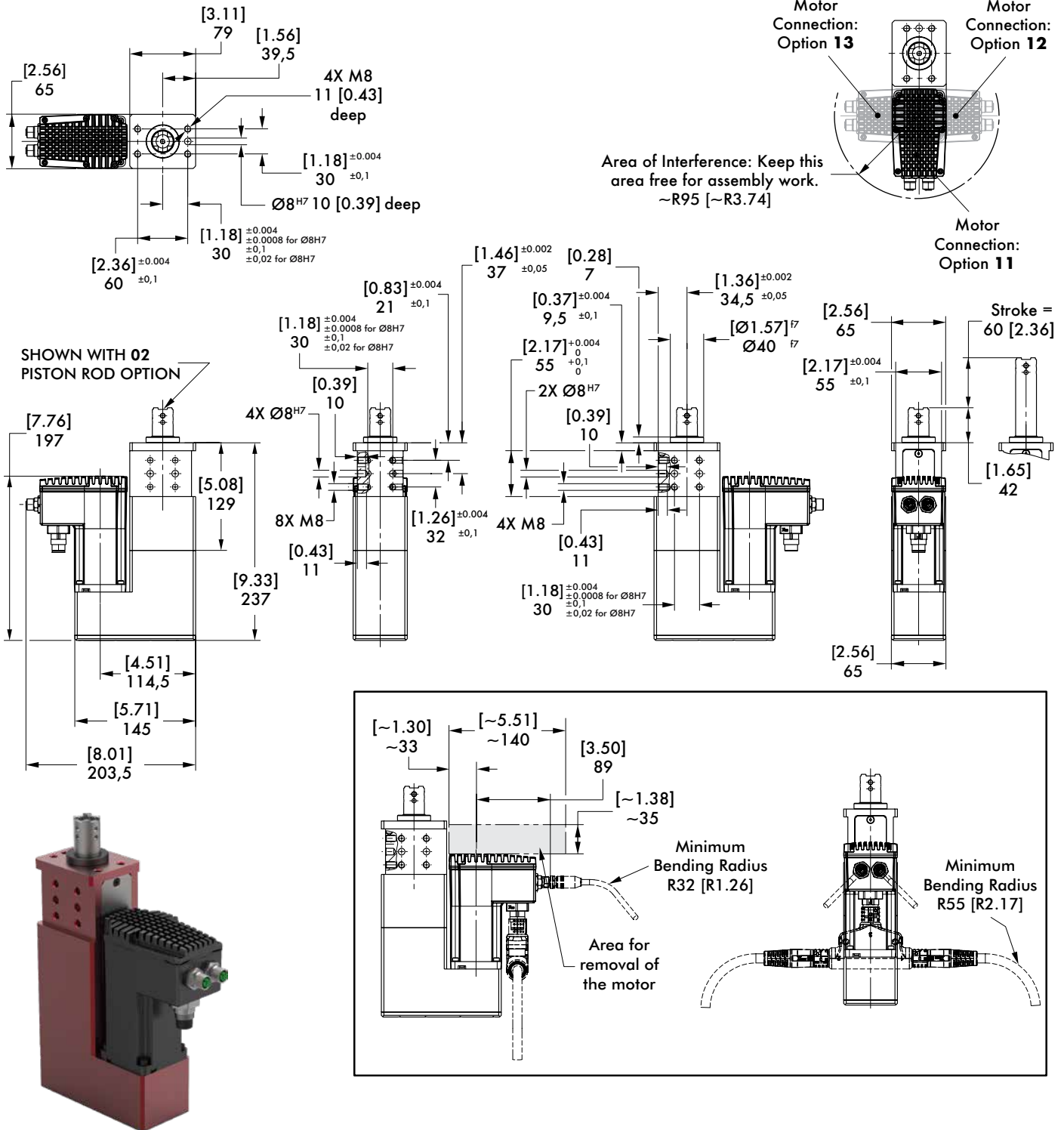

Base Model	Stroke mm [in]	Thrust Force N [lbf]	Retraction Force N [lbf]	Speed Max. mm/s [in/s]	Weight Kg [lbs]
96W-11.02..60	[0-2.36] 0-60	[225] 1000	[225] 1000	[2.36] 60	[13.23] 6,0

96W-1 PISTON RODS

Electric Pin Package | Smart Pin Package | Dimensions

02 Ø16 mm M6 Threaded Inside Hole, Cross Groove

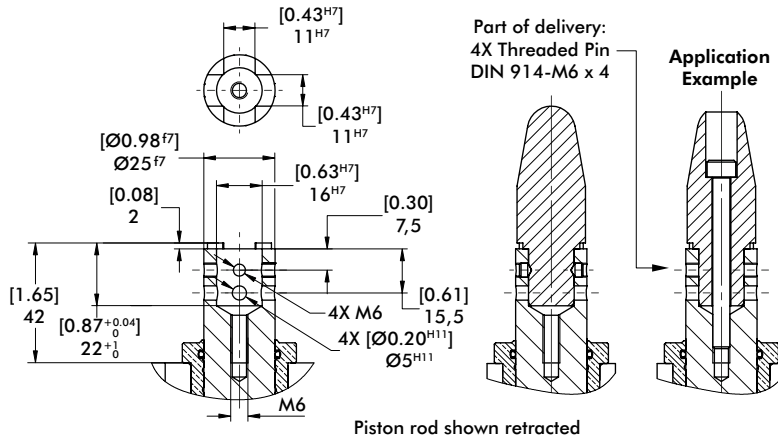

04, A4, B4, C4 NAAMS Standard

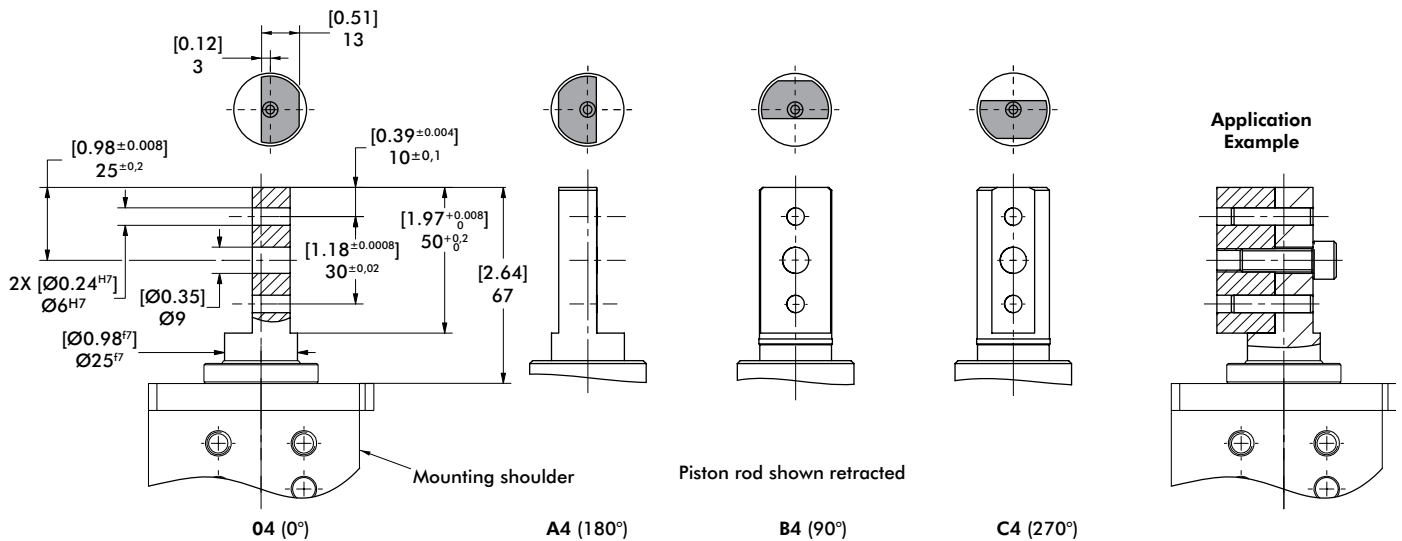

05 Ø10 mm Inside Hole, Cross Groove

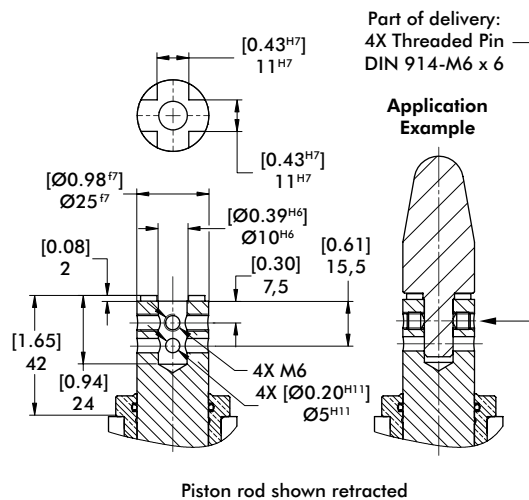

98W03-2

Electric Pivot Unit | Ordering Information

98W03-2 10 A 0 - 00 - 0

Motor	Description
10	SEW 400V-Brake

Hard Stop	Description
0	Standard Stop
1R	Audi-Standard Reference Position
1A	Audi-Standard Working Position 0°

Swivel Arm	Description
A	Center of Pivot Point
B	Below Pivot Point
C	Above Pivot Point

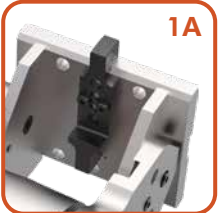
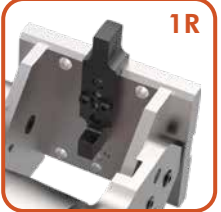
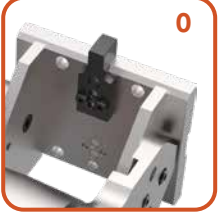
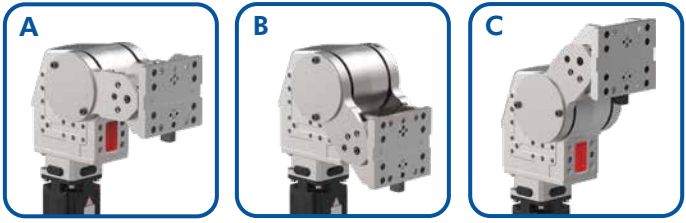

Connections

- 0 Facing Back
- 1 Facing Left
- 2 Facing Front
- 3 Facing Right

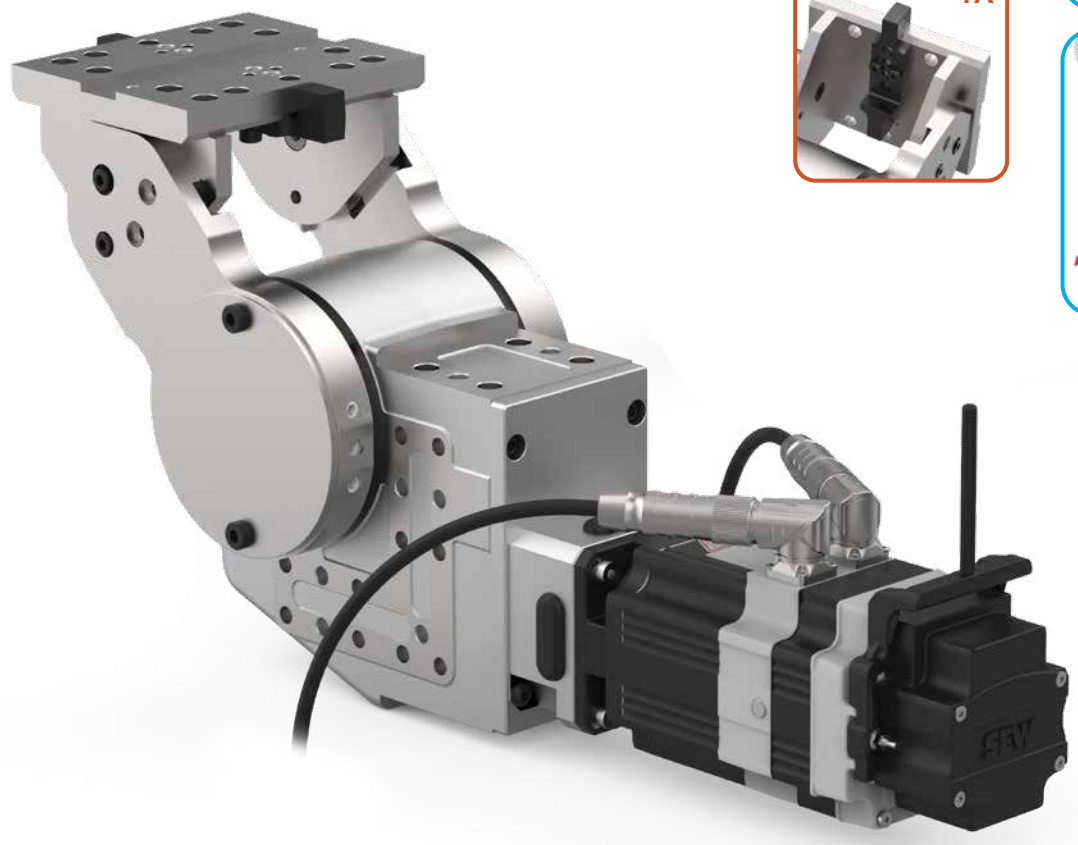
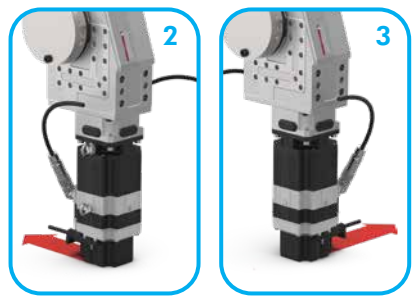
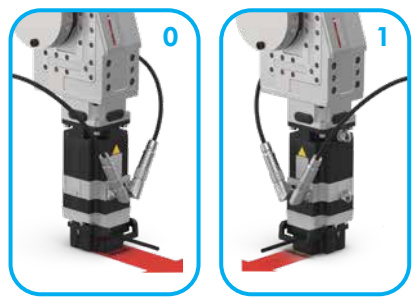

98W03-210

Holding Torque:
2000 Nm [1475 ft-lb]

Compact size and lightweight design

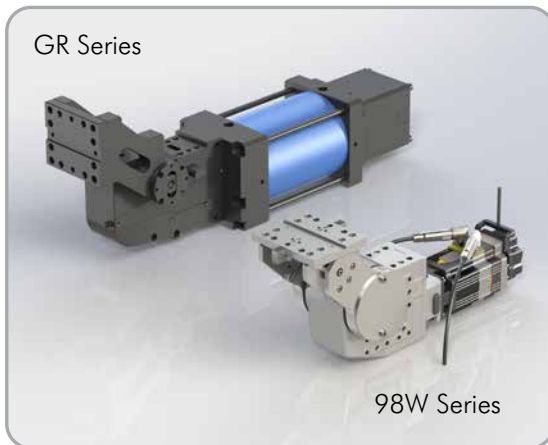

The 98W series electric pivot unit can share the same mounting pattern as the pneumatic pivot units, while providing greater energy savings with reduced size and weight.

One electric pivot unit replaces four sizes of pneumatic pivot units

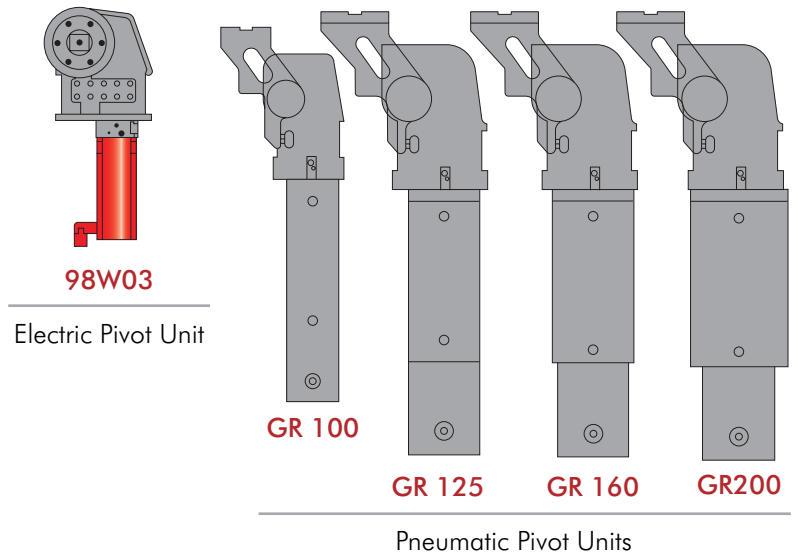

Easily adjustable saddle arm and mount

The saddle arm of the electric pivot unit can be adjusted into three different starting positions. Each starting position allows the saddle arm to be pivoted from 135° up to 210°.

Without the saddle arm, the pivot unit can be used as a rotate with 360° rotation.

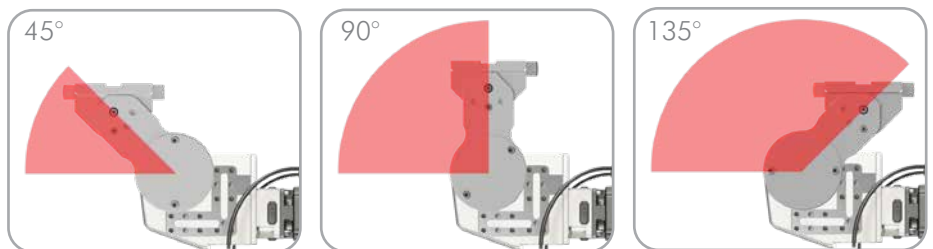

Application Example

98W Series shown with a holding fixture mounted to the saddle mount.



Operating Principle

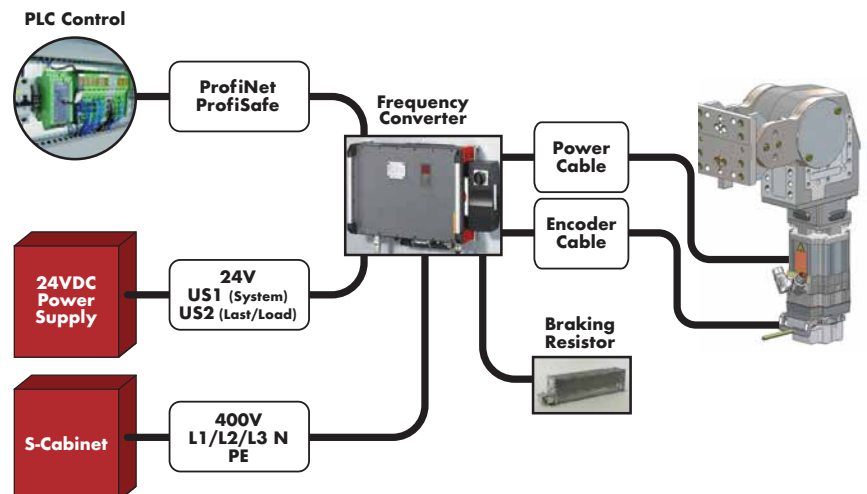

98W03-2

Electric Pivot Unit | Dimensions

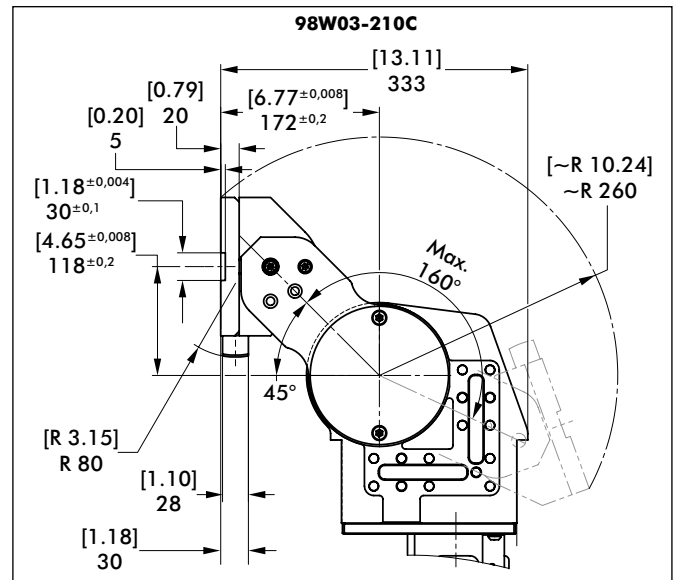
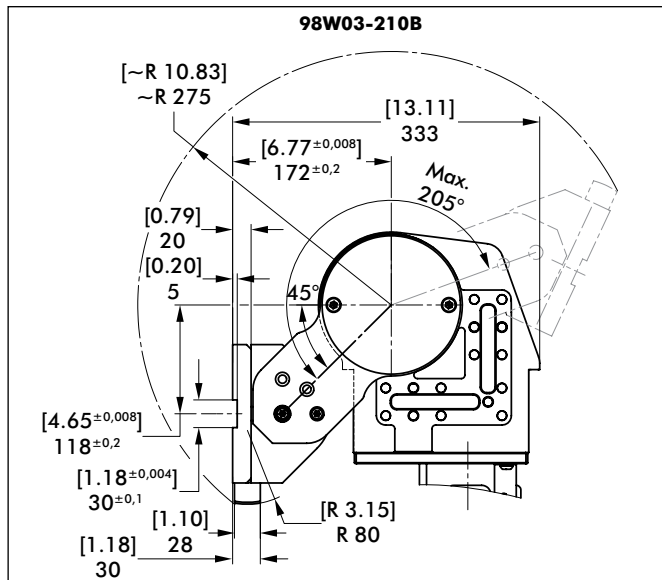
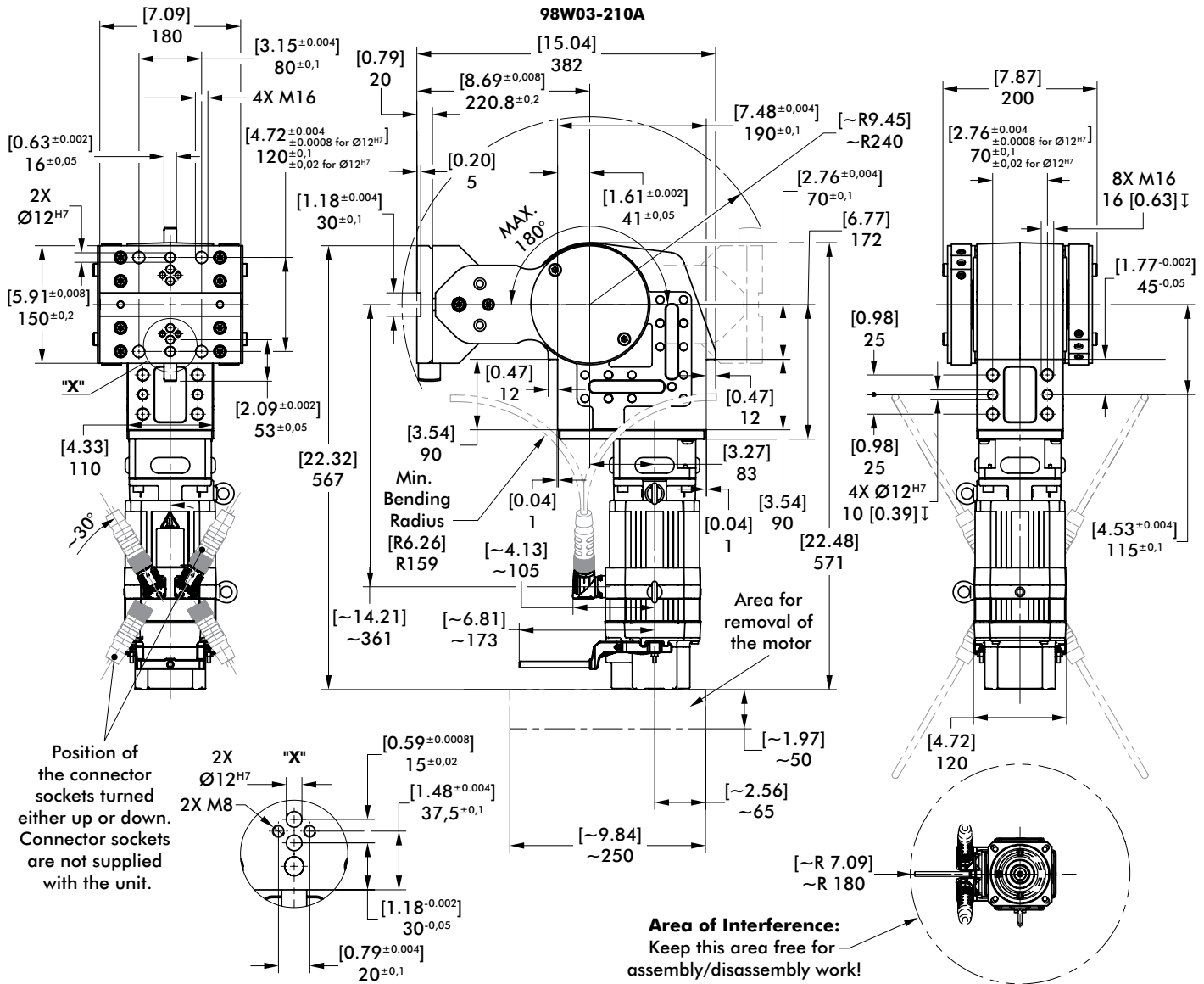

Specification	Units	98W03-210
Input supply voltage for external controller:	VAC	400
Control signals from external PLC		
Return signal to external PLC		
Speeds:		
Rotation from 135° to 0°	sec	4 @ 135°
Holding	sec	3
Rotation from 0° to 135°	sec	4 @ 135°
Holding	sec	3
Gear Ratio		420:1
Torque	Nm [in-lb]	500 [4425]
Static Holding Torque	Nm [in-lb]	2000 [17,701]
Max. Motor Torque (must be limited on the control side)	Nm [in-lb]	6 [53.1]
Max. Permissible Motor Speed	RPM	6000 1/min
Duty Cycle		70%
Permissible Output Speed:		
Radial	N [lbf]	2000 [17,701]
Axial	N [lbf]	5000 [44,254]
E-Stop	N [lbf]	0.4 sec @ 500 [0.4 sec @ 112] = ca. 10°
Acceleration	sec	2
Slow down	sec	2
Weight	Kg [lb]	51,5 [113.54]
Operating Temperature	C° [F°]	0° - 60° [32° - 140°]
Repeatability with Hard Stop	mm [in]	± 0,01 @ 500 [± 0.0004 @ 19.69]
Repeatability without Hard Stop	mm [in]	± 0,05 @ 500 [± 0.002 @ 19.69]

Driving Time and Angle Guidelines

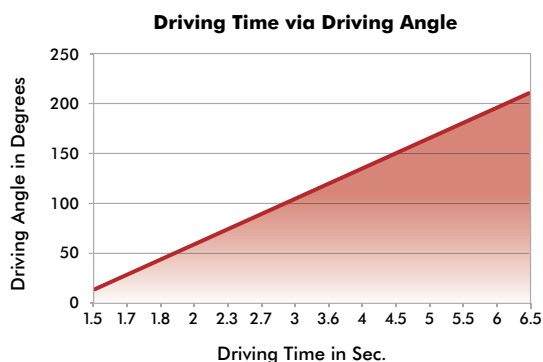

Note:
 Maximum speed should not exceed 6000 rpm.
 Velocity must never be in a trapezoidal profile.
 The velocity must have a triangular or sinusoidal shape. Acceleration ramps or jolt files must be adjusted corresponding to the driving angle.

Driving Angle Degrees	Driving Time Sec.	Max Speed RPM	Jolt Time Sec.	Acceleration Ramp ms	Braking Ramp ms	Amplification X-Controller
15	1.4	4017	0.1	500	500	2.23
30	1.7	5862				
45	1.8	6000		400	400	
60	2.0					
75	2.3					
90	2.7			500	500	
105	3.0			600	600	
120	3.6			800	800	
135	4.0	600		600		
150	4.5	5700		700	700	
165	5.0					
180	5.5			800	800	
195	6.0	4500				
210	6.5					