

**Orientalmotor**

Brushless Motor and Driver Packages  
**NexBL BMU Series**

Easy Speed Control with Spin and Push



30 W Full Size

# Easy Speed Control with Spin and Push

A settings dial designed for easy speed control.

Once the motor and the driver are connected, all you do for this simple wiring is turn on the switch.

Introducing the NexBL **BMU** Series, which is committed to your ease of use of the product.

The new brushless motor NexBL is a compact, high-power, and high-efficiency motor.

It offers the highest standards of speed control now at an affordable price.



Brushless Motor and Driver Packages

# NexBL **BMU** Series



NexBL is a new brushless motor from Oriental Motor. The entire structure has been innovated in pursuit of the optimal performance from a motor. It realizes a first-ever compactness, high power and high efficiency for a motor.

- ① Spin and push. Easy speed control.
- ② Easy wiring. Quick start.
- ③ Opening the panel reveals extensive functions.
- ④ New Brushless Motor—NexBL.



# NexBL **BMU** Series Operation Procedure



# ① Spin and push. Easy speed control.



Turn the dial, and set the speed to your desired speed.

Turning the settings dial has a similar feeling as with clicking. Turning the dial clockwise increases the speed, while turning it counterclockwise reduces the speed.



Turning the dial slowly changes the speed by 1 r/min.

While observing the indication, turn the dial slowly to the right, and notice that speed increases by 1 r/min. While turning it slowly to the left, notice that the speed decreases by 1 r/min.



Pushing the dial sets the speed.

Once the desired value for speed is set. When power is re-supplied after setting the speed, the motor operates according to the set speed.



The dial operation can be locked.

After the speed has been set, it can be changed by operating the dial. The dial can be locked to prevent changes in speed with the dial operation. →Page 9



# NexBL **BMU** Series Connection and Activation

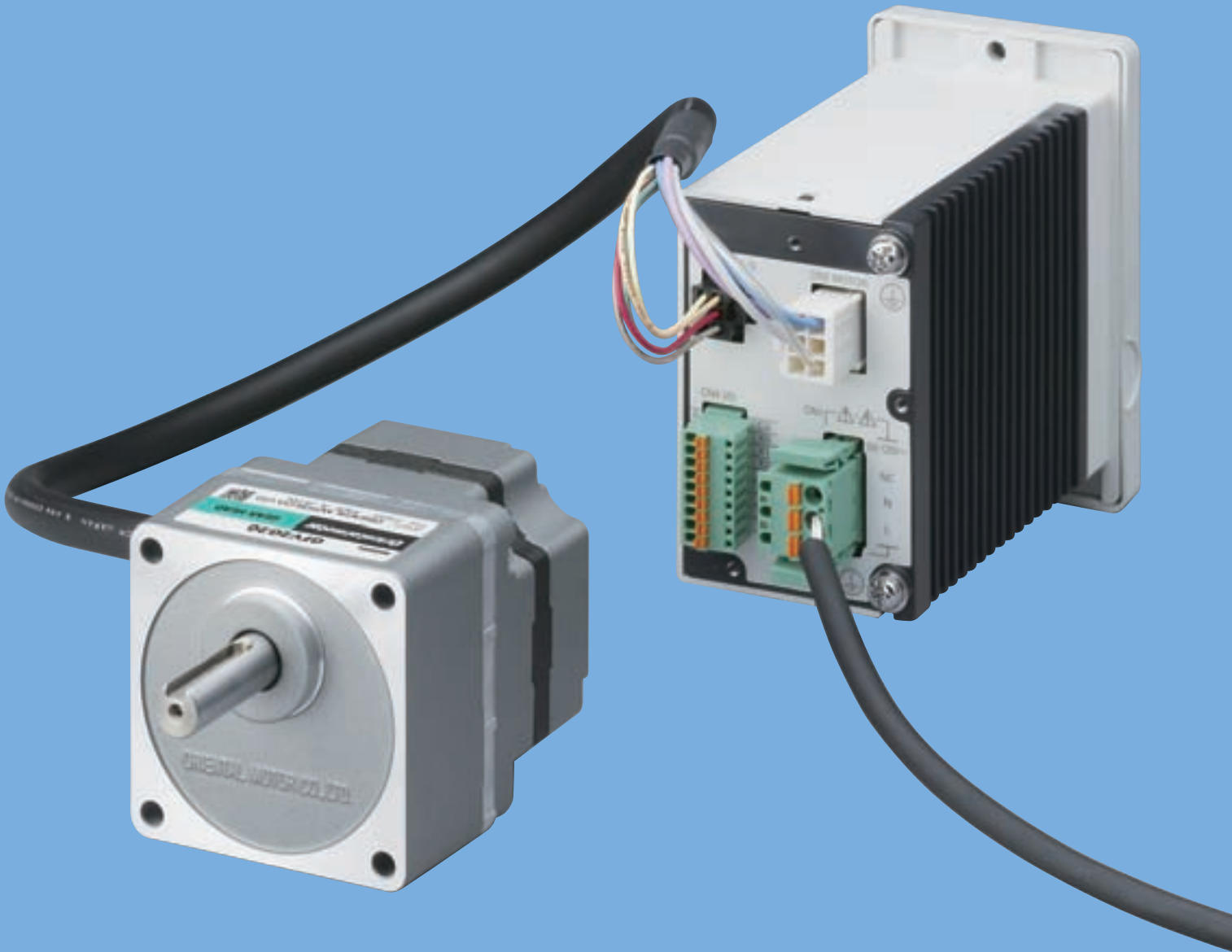

## ② Easy wiring. Quick start.



The motor and driver can be easily connected.

The motor connector is compact, and it easily passes through the flexible conduit and the cable gland.



The power and I/O connectors are of the screwless type.

There is no need for welding or special crimp tools when connecting the power connector and the I/O connector. While pushing the orange button, just insert the lead wire.



With only one switch, the motor can be started immediately.

The motor starts when the switch is set to the "RUN" position.

If set to the "STAND-BY" position, the motor decelerates to a stop.

The motor can be easily operated with the operating switch on the front side.



The rotation direction of the motor can be changed with easy operation.

Switching the rotation direction is possible with the rotation direction switch. It is possible even when the motor is in operation.



# NexBL **BMU** Series

## Extensive Functions





# ③ Opening the panel reveals the extensive functions.

## Various functions can be set on the driver.

(Typical functions that can be set while the front panel is opened)

- Motor Startup/Stop\*
- Adjustment of operating speed\*
- Setting the operating speed\*
- Selecting the rotation direction\*
- Changing the indication
- Operating speed indication when the speed reduction/speed increasing ratio is set
- Setting the acceleration/deceleration time
- Dial operation lock
- Speed Setting for the 4-Speed Operation
- Speed limits setting.
- Validating the external operating signals
- External input/output signal allocation
- Setting the overload alarm detection time, except during axial lock
- Easy holding function for Output shaft.

\*Setting is possible even if the front panel is attached.



**MODE key**

This changes the operating mode.

**FUNCTION key**

This changes the indication and functions for an operating mode.

## Load factor can be shown.

With the rated torque of the motor at 100% , the load factor can be expressed in percentage (40-200% ). The load condition during the start-up, as well as the load condition due to the aging deterioration of the equipment can be confirmed.



Indication at a load factor of 50%

## Lock the dial operation.

This prevents the undesired changes in the speed and the changes or deletion of data with the operation of the dial.

- Setting the Lock Function

At the main screen for each operating mode, press the "MODE" key for 5 seconds or more. When "Lk" appears, the lock function is activated.



- Cancelling the lock function

Return to the main screen, and press the "MODE" key for 5 seconds or more. When "UnLk" is indicated, the lock function has been cancelled.



Acceleration/deceleration time potentiometer

## 4-Speed Setting.

Operation in 4 speeds is possible by setting the data to operating data No.0, No.1, No.2, or No.3, and switching the input of the M0 terminal.

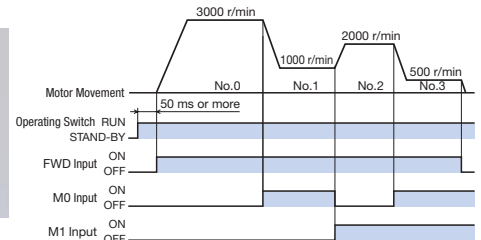

## Indicates the transport speed of the conveyor.

The conveyor gear ratio is computed and set into the "gear ratio" parameters, and the conveyor transport speed can be indicated. As the conveyor transport speed can be checked directly, it is convenient for frequent changing of setup and other processes involved in the manufacturing process.

## Sets the acceleration time and deceleration time.

The acceleration time and deceleration time can be digitally set, in addition to adjusting them with an acceleration/deceleration time potentiometer.

- Setting Range: 0.0~15.0 sec (Initial value: 0.5 sec)

For the digital setting, the acceleration time and deceleration time are each set independently. Therefore, the time can be freely set according to the desired tact time of the equipment.

## Set the upper and lower rotation speed limits.

The upper and lower limits for the speed control range can be set. The speed limits can be set with the monitor mode or data mode.

## Output shaft is held when stopped.

When the motor is stopped, the load can be electrically held. (Holding force is up to 50% of the rated torque.)

**[Note]**

If the electrical power supply to the driver is turned OFF, the holding force dissipates. This cannot be used to prevent a fall during a power outage.



# NexBL **BMU** Series

## Motor Features



# ④ New Brushless Motor NexBL

## NexBL designed for compactness, high power and high efficiency

An optimal magnetic design and high-performance material enable a NexBL stator plate thickness of just 11.2 mm. This slimness realizes a highly efficient power unit that outputs 120 W. Compared with the conventional brushless motor of the same output power, the stator plate thickness is only half of the conventional one (For motors with a frame size of 90 mm). Moreover, the use of high-performance material reduces the amount of material used, therefore reducing costs.

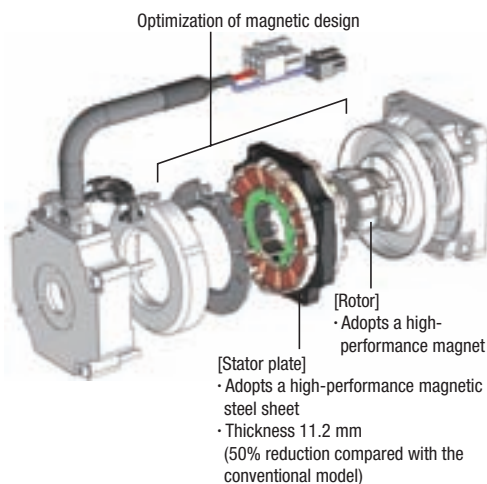

## Substantial improvement in the efficiency of the motor and driver package

NexBL **BMU** Series enabled a substantial improvement in the efficiency of the motor and driver package.

- A maximum of 15% improvement of the efficiency of the package\*1
- Exceeds global standards IE3\*2

\*1 NexBL **BMU** Type 30 W and **BLU** Series 20 W Comparison

\*2 Established highest efficiency level for the International Standards IEC60034-30.

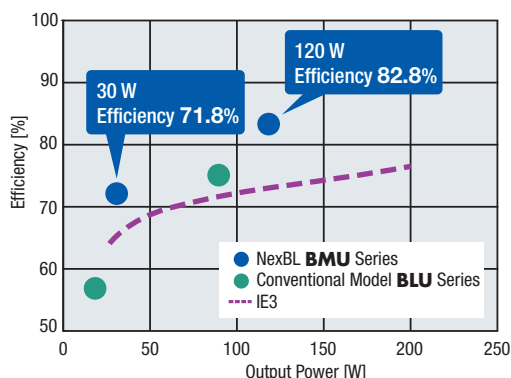

## NexBL and Three-Phase Motor Comparison

Weight reduction and slim body are realized with the high-power NexBL. For example, compared with the three-phase induction motor of frame size 90 mm, NexBL has the following advantages:

### ● Downsizing of the Equipment

Motor mass of 2.0 kg (Approx. 63%) reduction, and overall length is 84.6 mm (Approx. 63%) shorter. On the other hand, motor output power increases by 1.3 times. A lightweight, slim, high-power motor enables downsizing of the equipment.

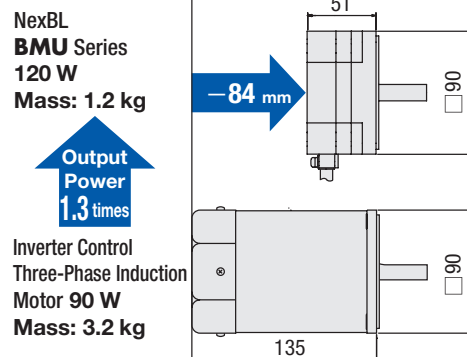

### ● Energy Savings of the Equipment

Motor output power is increased by 1.3 times, while motor loss is reduced by 26%. This motor is effective for energy savings of the equipment.

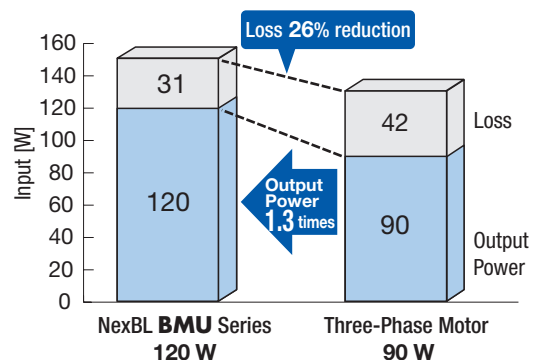

# The highest standards of speed control now available at an affordable price.

## Highest standards of speed control.

**Maximum Speed of 4000 r/min**

**Speed ratio 1:50 (2.5 times of the conventional ratio)**

NexBL **BMU** Series has a maximum speed of 4000 r/min.

Speed ratio of 1:50 (80 to 4000 r/min) is realized. Speed regulation has been greatly improved from  $\pm 0.5\%$  to  $\pm 0.2\%$ . With the highest standards of speed control, we respond to our customers' demands.

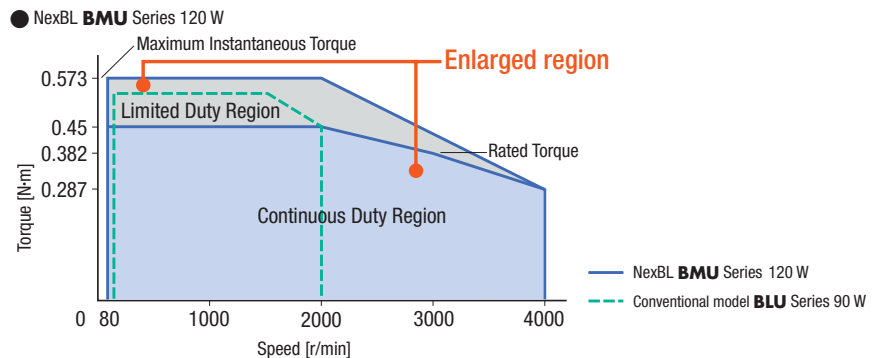

## User-friendly features and extensive functions, all available at an affordable price.

For example, the set price for NexBL **BMU** Series of frame size 60 mm is much cheaper compared with an equivalent conventional model.



### Conventional Model **BLU** Series

- Output Power: 20 W
- Gearhead gear ratio: 5
- Permissible torque: 0.45 N·m
- Speed range: 20~400 r/min



### NexBL **BMU** Series

- Output Power: 30 W
- Gearhead gear ratio: 5
- Permissible torque: 0.45 N·m
- Speed range: 16~800 r/min



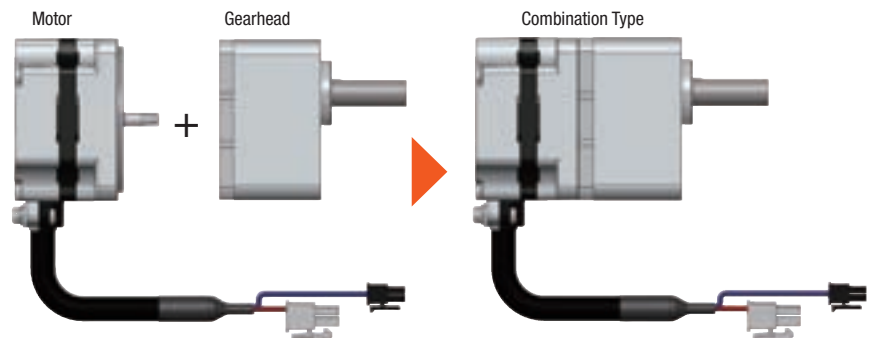

● For price and lead time please contact the nearest Oriental Motor office, or visit our website.

## New gearhead combination type.

With the gearhead's boss section and cut on the installation surface, the installation accuracy with the equipment has been improved. It also achieved lower noise, compared with the conventional model. Since the motor and gearhead comes in a preassembled combination type, it can easily be attached to the equipment. The motor, driver, and gearhead comes together, saving time and effort for procurement.



## Lineup

Motor	Frame Size	Output Power	Package			
			Type	Driver	Power Supply Voltage	Connection Cable
 Combination Type	60 mm	30 W	Standard (IP20) or IP65		Single-Phase 100-120 VAC Single-Phase 200-240 VAC Three-Phase 200-240 VAC	 1 m, 2 m, 3 m or not included
	Combination Type 80 mm Round Shaft Type 60 mm	60 W				
 Round Shaft Type*	90 mm	120 W				

\* For some round shaft types, the shaft is processed with a shaft flat.

# Brushless motors, which are suitable for speed control, have the following features:

In a brushless motor, there are no brushes, and thus no physical contact that could lead to frictional energy losses. While DC motors use a brush and commutator to rotate and require regular maintenance, brushless motors rotate by the ON/OFF operation of the drive circuit transistor, based on the signals detected by the hall effect IC (magnetic sensor). Brushless motors are more expensive to design and manufacture, but they are typically more efficient than brushed motors.

This leads to:

- Less maintenance and longer life
- More power
- Longer runtime

## Stable speed control

Brushless motors compare the setting speed with the speed feedback signals from the motor at all times, and adjusts the motor's applied voltage. For this reason, even if the load changes, stable rotation is performed from low speed to high speed. Inverter-controlled (V/f control) three-phase induction motors do not perform, so the speed will drop significantly when the load increases. Brushless motors are recommended for applications that require speed stability.

● Speed change comparison at a load factor of 80% (Reference values)\*

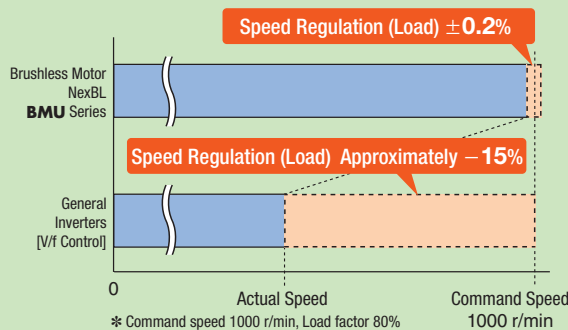

## Wide Speed Control Range

The brushless motor has a broader speed control range compared to AC speed control motors and inverters. Unlike AC speed control motors, the torque at low speed is not limited, so brushless motors are suited to applications that require a constant torque from low speed to high speed.

Product Group	Speed Control Range*	Speed Ratio
Brushless Motor NexBL BMU Series	80~4000 r/min	1:50
Inverter-Controlled Three-Phase Induction Motor	200~2400 r/min	1:12
AC Speed Control Motor	50 Hz : 90~1400 r/min	1:15
	60 Hz : 90~1600 r/min	1:17

\* The speed control range varies depending on the model.

## Contributes to Energy Savings

Brushless motors, which incorporate permanent magnets in the rotor, generate little secondary loss from the rotor. This allows for power consumption to be reduced by approximately 23% compared with inverter-controlled three-phase induction motors.\* This contributes to energy savings with the equipment.

\* When output power is 60 W

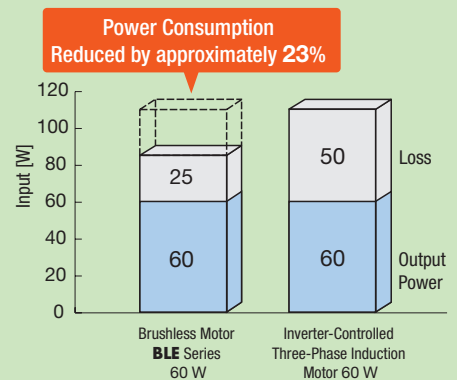

## Compact and Powerful

Brushless motors have slim body and provide high power due to permanent magnets being used in the rotor. For example, the overall length is 84 mm shorter and the output power is 1.3 times higher than that of three-phase induction motors with a frame size of 90 mm. Using brushless motors can contribute to downsizing of equipment.



Brushless Motor NexBL BMU Series 120 W

↑ Output Power 1.3 times

Inverter-Controlled Three-Phase Induction Motor 90 W

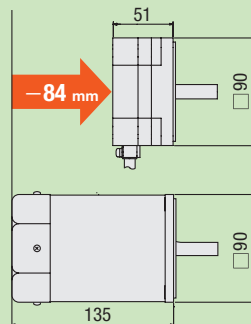

## Equipped with protective functions that output an alarm

Various protective functions such as overload protective function and overvoltage protective function are equipped. An alarm is output when a protective function activates.

## System Configuration

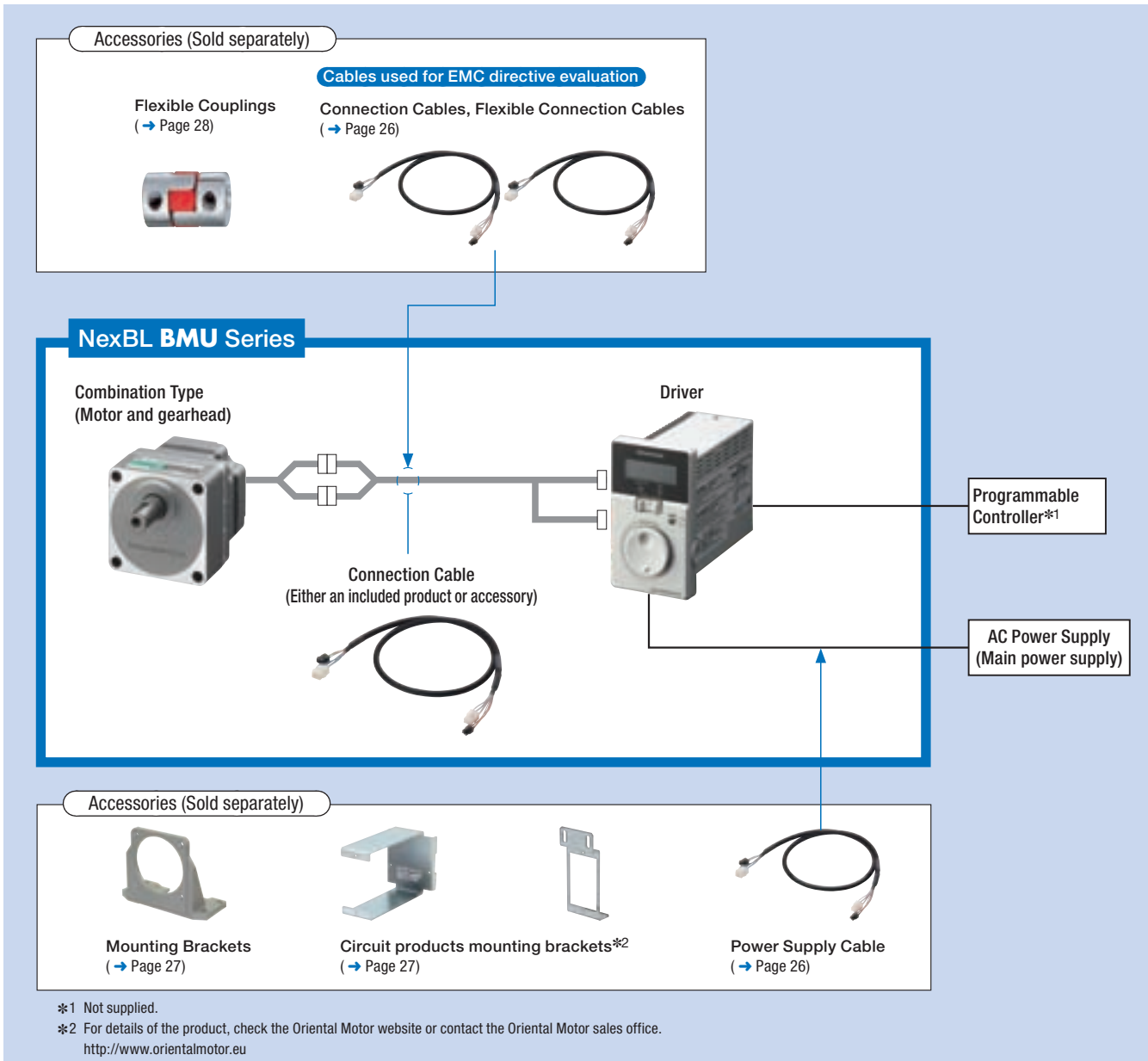

### System Configuration

<b>NexBL BMU Series</b> Combination Type - Parallel Shaft <b>BMU5120A-10-3</b>	+	Sold Separately		
		Connection Cable (7 m) <b>CC07BLE</b>	Mounting Bracket <b>SOL5M8F</b>	Flexible Coupling <b>MCL551818</b>

The system configuration shown above is an example. Other combinations are available.

### Product Number Code

**BMU 5 120 A P -10 - 1**

① ② ③ ⑤ ⑥ ⑦ ⑧

**BMU 4 60 S A P -10 - 1**

① ② ③ ④ ⑤ ⑥ ⑦ ⑧

①	Type	<b>BMU:</b> NexBL <b>BMU</b> Type
②	Frame Size	<b>2:</b> 60 mm <b>4:</b> 80 mm <b>5:</b> 90 mm
③	Output Power (W)	<b>30:</b> 30 W <b>60:</b> 60 W <b>120:</b> 120 W
④	Identification number	<b>S</b>
⑤	Power Supply Voltage	<b>A:</b> Single-Phase 100-120 VAC <b>C:</b> Single-Phase, Three-Phase 200-240 VAC
⑥	Motor Degree of Protection	None: Standard type (IP20 specification) <b>P:</b> IP65 Specification
⑦	Gear Ratio/Shaft Configuration	Number: Gear Ratio for Combination Types <b>A:</b> Round Shaft Type <b>AC:</b> Round Shaft Type (Shaft flat processed)
⑧	Connection Cable Length (Included)	Number: Included Connection Cable Length <b>-1:</b> 1 m <b>-2:</b> 2 m <b>-3:</b> 3 m None: Connection cable not included

Examples of product names that indicate connection cable availability and length

Includes a 3 m connection cable → **BMU5120A-10-3**

No connection cable → **BMU5120A-10**

## Product Line

### Combination Type

The combination type comes with the motor and its dedicated gearhead pre-assembled. This simplifies mounting in equipment. Motors and gearheads are also available separately to facilitate changes in motor and gearhead combinations and if spare gearheads are required.

- You may purchase the motor unit with connection cable (1 m, 2 m, 3 m).  
For price and lead time please contact the nearest Oriental Motor office, or visit our website.

### Combination Type – Parallel Shaft Gearhead

#### ◇ Standard Type (IP20 specification)

Output Power	Power Supply Voltage	Product Name	Gear Ratio
30 W	Single-Phase 100-120 VAC	<b>BMU230A</b> -□◇	<b>5, 10, 15, 20</b> <b>30, 50, 100</b> <b>200</b>
	Single-Phase, Three-Phase 200-240 VAC	<b>BMU230C</b> -□◇	<b>5, 10, 15, 20</b> <b>30, 50, 100</b> <b>200</b>
60 W	Single-Phase 100-120 VAC	<b>BMU460SA</b> -□◇	<b>5, 10, 15, 20</b> <b>30, 50, 100</b> <b>200</b>
	Single-Phase, Three-Phase 200-240 VAC	<b>BMU460SC</b> -□◇	<b>5, 10, 15, 20</b> <b>30, 50, 100</b> <b>200</b>
120 W	Single-Phase 100-120 VAC	<b>BMU5120A</b> -□◇	<b>5, 10, 15, 20</b> <b>30, 50, 100</b> <b>200</b>
	Single-Phase, Three-Phase 200-240 VAC	<b>BMU5120C</b> -□◇	<b>5, 10, 15, 20</b> <b>30, 50, 100</b> <b>200</b>

#### ◇ IP65 Specification

Output Power	Power Supply Voltage	Product Name	Gear Ratio
30 W	Single-Phase 100-120 VAC	<b>BMU230AP</b> -□◇	<b>5, 10, 15, 20</b> <b>30, 50, 100</b> <b>200</b>
	Single-Phase, Three-Phase 200-240 VAC	<b>BMU230CP</b> -□◇	<b>5, 10, 15, 20</b> <b>30, 50, 100</b> <b>200</b>
60 W	Single-Phase 100-120 VAC	<b>BMU460SAP</b> -□◇	<b>5, 10, 15, 20</b> <b>30, 50, 100</b> <b>200</b>
	Single-Phase, Three-Phase 200-240 VAC	<b>BMU460SCP</b> -□◇	<b>5, 10, 15, 20</b> <b>30, 50, 100</b> <b>200</b>
120 W	Single-Phase 100-120 VAC	<b>BMU5120AP</b> -□◇	<b>5, 10, 15, 20</b> <b>30, 50, 100</b> <b>200</b>
	Single-Phase, Three-Phase 200-240 VAC	<b>BMU5120CP</b> -□◇	<b>5, 10, 15, 20</b> <b>30, 50, 100</b> <b>200</b>

The following items are included in each product.

Motor, driver, gearhead\*1, connection cable\*2, CN1 connector, CN4 connector, installation screws\*1, machine key\*1, operating manual

\*1 Combination type only

\*2 Only with types supplied with a connection cable

- A number indicating the gear ratio is specified in the box □ in the product name.

When the accessory connection cable is supplied, a number indicating the length of the cable, **-1** (1 m), **-2** (2 m), or **-3** (3 m), is specified in the box ◇ in the product name.

For motors with a degree of protection of IP65 specification, **P** is specified where the box ■ appears in the product name.

## ● Round Shaft Type

### ◇ Standard Type (IP20 specification)

Output Power	Power Supply Voltage	Product Name
30 W	Single-Phase 100-120 VAC	<b>BMU230A-A</b> ◇
	Single-Phase, Three-Phase 200-240 VAC	<b>BMU230C-A</b> ◇
60 W	Single-Phase 100-120 VAC	<b>BMU260A-A</b> ◇
	Single-Phase, Three-Phase 200-240 VAC	<b>BMU260C-A</b> ◇
120 W	Single-Phase 100-120 VAC	<b>BMU5120A-A</b> ◇
	Single-Phase, Three-Phase 200-240 VAC	<b>BMU5120C-A</b> ◇

### ◇ IP65 Specification

Output Power	Power Supply Voltage	Product Name
30 W	Single-Phase 100-120 VAC	<b>BMU230AP-A</b> ◇
	Single-Phase, Three-Phase 200-240 VAC	<b>BMU230CP-A</b> ◇
60 W	Single-Phase 100-120 VAC	<b>BMU260AP-A</b> ◇
	Single-Phase, Three-Phase 200-240 VAC	<b>BMU260CP-A</b> ◇
120 W	Single-Phase 100-120 VAC	<b>BMU5120AP-A</b> ◇
	Single-Phase, Three-Phase 200-240 VAC	<b>BMU5120CP-A</b> ◇

The following items are included in each product.

Motor, driver, gearhead\*1, connection cable\*2, CN1 connector, CN4 connector, installation screws\*1, machine key\*1, operating manual

\*1 Combination type only

\*2 Only with types supplied with a connection cable

## ● Lineup of Other Products

Round Shaft Type  
Shaft Flat Cutout on Output Shaft

● For details of the products processed with a shaft flat cutout, check the Oriental Motor website or contact the Oriental Motor sales office.

## ■ Motor and Driver Combinations

### ● Combination Type – Parallel Shaft Gearhead

Output Power	Power Supply Voltage	Product Name	Combination Motor Product Name*	Motor Product Name	Gearhead Product Name	Driver Product Name
30 W	Single-Phase 100-120 VAC	<b>BMU230A</b> ■-□◇	BLM230■-□	BLM230■-GFV	GFV2G□	BMUD30-A
	Single-Phase, Three-Phase 200-240 VAC	<b>BMU230C</b> ■-□◇				BMUD30-C
60 W	Single-Phase 100-120 VAC	<b>BMU460SA</b> ■-□◇	BLM460S■-□	BLM460S■-GFV	GFV4G□	BMUD60-A
	Single-Phase, Three-Phase 200-240 VAC	<b>BMU460SC</b> ■-□◇				BMUD60-C
120 W	Single-Phase 100-120 VAC	<b>BMU5120A</b> ■-□◇	BLM5120■-□	BLM5120■-GFV	GFV5G□	BMUD120-A
	Single-Phase, Three-Phase 200-240 VAC	<b>BMU5120C</b> ■-□◇				BMUD120-C

\*For combination motors, the product name applies to the motor and gearhead combination.

## ● Round Shaft Type

Output Power	Power Supply Voltage	Product Name	Motor Product Name	Driver Product Name
30 W	Single-Phase 100-120 VAC	<b>BMU230A</b> ■-A◇	BLM230■-A	BMUD30-A
	Single-Phase, Three-Phase 200-240 VAC	<b>BMU230C</b> ■-A◇		BMUD30-C
60 W	Single-Phase 100-120 VAC	<b>BMU260A</b> ■-A◇	BLM260■-A	BMUD60-A
	Single-Phase, Three-Phase 200-240 VAC	<b>BMU260C</b> ■-A◇		BMUD60-C
120 W	Single-Phase 100-120 VAC	<b>BMU5120A</b> ■-A◇	BLM260■-A	BMUD120-A
	Single-Phase, Three-Phase 200-240 VAC	<b>BMU5120C</b> ■-A◇		BMUD120-C

● A number indicating the gear ratio is specified in the box □ in the product name.

When the accessory connection cable is supplied, a number indicating the length of the cable, **-1** (1 m), **-2** (2 m), or **-3** (3 m), is specified in the box ◇ in the product name.

For motors with a degree of protection of IP65 specification, **P** is specified where the box ■ appears in the product name.



## Specifications

### 30 W (RoHS)



Product Name	Combination Type – Parallel Shaft Gearhead		BMU230A□-□◇		BMU230C□-□◇	
	Round Shaft Type		BMU230A□-A◇		BMU230C□-A◇	
Rated Output Power (Continuous)	W		30			
Rated Speed	r/min		3000			
Rated Torque	N·m		0.096			
Maximum Instantaneous Torque	N·m		0.144			
Rotor Inertia	J: $\times 10^{-4}$ kg·m <sup>2</sup>		0.042			
Round Shaft Type Permissible Inertia	J: $\times 10^{-4}$ kg·m <sup>2</sup>		1.8			
Speed Control Range			80~4000 r/min (Speed ratio 1:50)			
Speed Regulation	Load		±0.2% or less: Conditions 0~rated torque, rated speed, rated voltage, normal temperature			
	Voltage		±0.2% or less: Conditions Rated voltage -15~+10%, rated speed, no load, normal temperature			
	Temperature		±0.2% or less: Conditions Operating ambient temperature from 0~+40°C, rated speed, no load, rated voltage			
Power Supply Input	Rated Voltage	VAC	Single-Phase 100-120		Single-phase 200-240/Three-phase 200-240	
	Permissible Voltage Range		-15~+10%			
	Frequency	Hz	50/60			
	Permissible Frequency Range		±5%			
	Rated Input Current	A	1.2	Single-phase: 0.7/ Three-phase: 0.38		
Maximum Input Current	A	2.0	Single-phase: 1.2/ Three-phase: 0.75			

### 60 W (RoHS)



Product Name	Combination Type – Parallel Shaft Gearhead		BMU460SA□-□◇		BMU460SC□-□◇	
	Round Shaft Type		BMU260A□-A◇		BMU260C□-A◇	
Rated Output Power (Continuous)	W		60			
Rated Speed	r/min		3000			
Rated Torque	N·m		0.191			
Maximum Instantaneous Torque	N·m		0.287			
Rotor Inertia	J: $\times 10^{-4}$ kg·m <sup>2</sup>		0.082			
Round Shaft Type Permissible Inertia	J: $\times 10^{-4}$ kg·m <sup>2</sup>		3.75			
Speed Control Range			80~4000 r/min (Speed ratio 1:50)			
Speed Regulation	Load		±0.2% or less: Conditions 0~rated torque, rated speed, rated voltage, normal temperature			
	Voltage		±0.2% or less: Conditions Rated voltage -15~+10%, rated speed, no load, normal temperature			
	Temperature		±0.2% or less: Conditions Operating ambient temperature from 0~+40°C, rated speed, no load, rated voltage			
Power Supply Input	Rated Voltage	VAC	Single-Phase 100-120		Single-phase 200-240/Three-phase 200-240	
	Permissible Voltage Range		-15~+10%			
	Frequency	Hz	50/60			
	Permissible Frequency Range		±5%			
	Rated Input Current	A	1.7	Single-phase: 1.0/ Three-phase: 0.52		
Maximum Input Current	A	3.3	Single-phase: 1.9/ Three-phase: 1.1			

### 120 W (RoHS)



Product Name	Combination Type – Parallel Shaft Gearhead		BMU5120A□-□◇		BMU5120C□-□◇	
	Round Shaft Type		BMU5120A□-A◇		BMU5120C□-A◇	
Rated Output Power (Continuous)	W		120			
Rated Speed	r/min		3000			
Rated Torque	N·m		0.382			
Maximum Instantaneous Torque	N·m		0.573			
Rotor Inertia	J: $\times 10^{-4}$ kg·m <sup>2</sup>		0.23			
Round Shaft Type Permissible Inertia	J: $\times 10^{-4}$ kg·m <sup>2</sup>		5.6			
Speed Control Range			80~4000 r/min (Speed ratio 1:50)			
Speed Regulation	Load		±0.2% or less: Conditions 0~rated torque, rated speed, rated voltage, normal temperature			
	Voltage		±0.2% or less: Conditions Rated voltage -15~+10%, rated speed, no load, normal temperature			
	Temperature		±0.2% or less: Conditions Operating ambient temperature from 0~+40°C, rated speed, no load, rated voltage			
Power Supply Input	Rated Voltage	VAC	Single-Phase 100-120		Single-phase 200-240/Three-phase 200-240	
	Permissible Voltage Range		-15~+10%			
	Frequency	Hz	50/60			
	Permissible Frequency Range		±5%			
	Rated Input Current	A	3.3	Single-phase: 2.0/ Three-phase: 1.1		
Maximum Input Current	A	6.8	Single-phase: 4.1/ Three-phase: 2.0			

● The values correspond to each specification and characteristic of a stand-alone motor. The speed-torque characteristics show the values when rated voltage is applied.

● A number indicating the gear ratio is specified in the box □ in the product name.

If the degree of protection of the motor is IP65 specification, P is entered where the box □ is located within the product name.

When the accessory connection cable is supplied, a number indicating the length of the cable, -1 (1 m), -2 (2 m), or -3 (3 m), is specified in the box ◇ in the product name.

## Speed – Torque Characteristics

Continuous Duty Region: Continuous operation is possible in this region.

Limited Duty Region : This region is used primarily when accelerating.

### 30 W

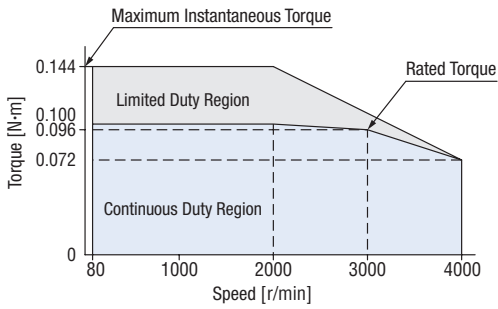

### 60 W

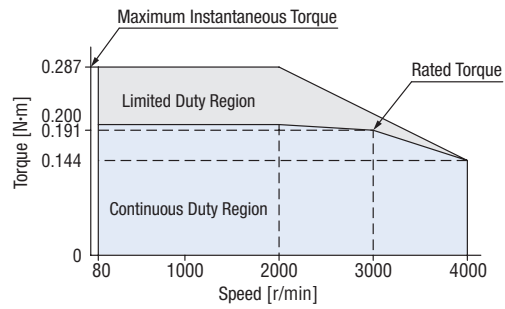

### 120 W

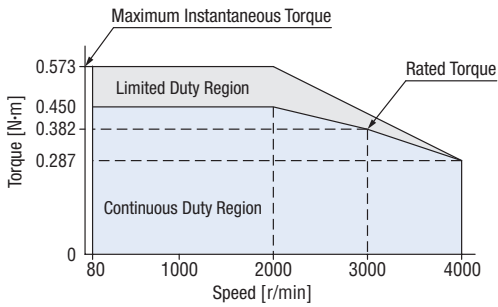

● The values correspond to each specification and characteristic of a stand-alone motor. The speed-torque characteristics show the values when rated voltage is applied.

## Common Specifications

Item	Specifications
Speed Setting Methods	Digital setting using the dial 4 speed settings possible
Acceleration/Deceleration Time	Analog setting: 0.1~15.0 s (Time setting from stopped state until reaching the rated speed) Common settings for acceleration/deceleration time with the use of acceleration/deceleration time potentiometer* Digital setting: 0.0~15.0 s (Time setting from current speed to the setting speed) Individual settings for acceleration time/deceleration time for each operating data* *Acceleration time/deceleration time varies with the load condition of the motor.
Input Signals	Photocoupler Input Input Resistance: 5.7 kΩ Operation due to internal power supply: 5 VDC Connectable External DC Power Supply: 24 VDC -15~+20% Current 100 mA or more Sink input/Source input Supplied through external wiring  Arbitrary signal assignment to X0~X2 input (3 points) is possible [ ]: Initial Setting [FWD], [REV], [MO], ALARM-RESET, EXT-ERROR, H-FREE
Output Signals	Photocoupler and Open-Collector Output External Power Supply: 4.5~30 VDC Current 100 mA or less Sink output/Source output Supplied through external wiring  Arbitrary signal assignment to Y0, Y1 (2 points) is possible [ ]: Initial Setting [ALARM-OUT1], [SPEED-OUT], ALARM-OUT2, MOVE, VA, WNG
Protective Function	When the following protective functions are activated, ALARM-OUT1 output turns OFF and the motor will undergo a coasting stop. At the same time, the alarm code will be displayed. (Instantaneous stop for external stop only) Overcurrent, Main circuit overheating, Overvoltage, Undervoltage, Sensor error, Overload, Overspeed, EEPROM error, Initial sensor error, Initial operation inhibition, External stop
Maximum Extension Distance	Motor and Driver Distance: 10.5 m (Accessory connection cable used)
Time Rating	Continuous

#### ● Overload Alarm Detection Time

The overload alarm is generated if the operation goes beyond the continuous duty region.  
The detection time for this overload alarm can be set from 0.1~60.0 seconds. (Initial setting: 30.0 seconds)  
However, alarm will be generated within 5 seconds in the following cases:

- If an applied load goes beyond the limited duty region
- If the output shaft is locked

## General Specifications

Item	Motor	Driver
Insulation Resistance	100 MΩ or more when 500 VDC megger is applied between the windings and the case after continuous operation under normal ambient temperature and humidity.	100 MΩ or more when 500 VDC megger is applied between the power supply terminal and the protective earth terminal, and between the power supply terminal and the I/O signal terminal after continuous operation under normal ambient temperature and humidity.
Dielectric Strength	Sufficient to withstand 1.5 kVAC at 50 Hz applied between the windings and the case for 1 minute after continuous operation under normal ambient temperature and humidity.	No abnormality is judged even with application of 1.5 kVAC at 50 Hz between the power supply terminal and the protective earth terminal, and with application of 1.5 kVAC at 50 Hz between the power supply terminal and the I/O signal terminal, for 1 minute after continuous operation under normal ambient temperature and humidity.
Temperature Rise	The maximum temperature rise of the windings is 50°C and that of the case is 40°C*1 when measured by the thermocouple method after rated continuous operation under normal ambient temperature and humidity.	Temperature rise of the heat sink is 50°C or less measured by the thermocouple method after rated continuous operation under normal ambient temperature and humidity.
Operating Environment	Ambient Temperature	0~+40°C (Non-freezing)
	Ambient Humidity	85% or less (non-condensing)
	Altitude	Up to 1000 m above sea level
	Atmosphere	No corrosive gases or dust. Cannot be used in a radioactive area, magnetic field, vacuum, or other special environments.
Vibration	Not subject to continuous vibration or excessive shock Conforms to JIS C 60068-2-6 "Sine-wave vibration test method" Frequency range: 10~55 Hz Pulsating amplitude: 0.15 mm Sweep direction: 3 directions (X, Y, Z) Number of sweeps: 20 times	
Storage Conditions*2	Ambient Temperature	-20~+70°C (non-freezing)
	Ambient Humidity	85% or less (non-condensing)
	Altitude	Up to 3000 m above sea level
Insulation Class	EN standard: 120 (E)	
Degree of Protection	Standard type: IP20 IP65 Specification: IP65 (Excluding the mounting surface of the round shaft type and connectors)	IP20

\*1 For round shaft types, attach to a heat sink (material: aluminum) of one of the following sizes to keep the motor case surface temperature from exceeding 90°C.

30 W Type: 115 ×115 mm Thickness 5 mm, 120 W Type: 165×165 mm Thickness: 5 mm

\*2 The storage condition applies to a short period such as a period during transportation.

### Note

Do not measure insulation resistance or perform a dielectric strength test while the motor and driver are connected.

## Permissible Torque of Combination Type

### Combination Type – Parallel Shaft Gearhead

Unit: N·m

Product Name	Gear Ratio	Motor Speed [r/min]	5	10	15	20	30	50	100	200
			80 r/min	16	8	5.3	4	2.7	1.6	0.8
<b>BMU230</b>	2000 r/min	400	200	133	100	66.7	40	20	10	
	3000 r/min	600	300	200	150	100	60	30	15	
	4000 r/min	800	400	267	200	133	80	40	20	
	At 80~2000 r/min	0.45	0.9	1.4	1.8	2.6	4.3	6	6	
<b>BMU460</b>	At 3000 r/min	0.43	0.86	1.3	1.7	2.5	4.1	6	6	
	At 4000 r/min	0.32	0.65	0.97	1.3	1.9	3.1	5.4	5.4	
	At 80~2000 r/min	0.9	1.8	2.7	3.6	5.2	8.6	16	16	
	At 3000 r/min	0.86	1.7	2.6	3.4	4.9	8.2	16	16	
<b>BMU5120</b>	At 4000 r/min	0.65	1.3	1.9	2.6	3.7	6.2	12.4	14	
	At 80~2000 r/min	2	4.1	6.1	8.1	11.6	19.4	30	30	
	At 3000 r/min	1.7	3.4	5.2	6.9	9.9	16.4	30	30	
	At 4000 r/min	1.3	2.6	3.9	5.2	7.4	12.3	24.7	27	

A colored background  indicates gear shaft rotation in the same direction as the motor shaft. Others rotate in the opposite direction.

## Permissible Radial Load/Permissible Axial Load

### Combination Type – Parallel Shaft Gearhead

Product Name	Gear Ratio		Permissible Radial Load		Permissible Axial Load N
			10 mm from output shaft end N	20 mm from output shaft end N	
<b>BMU230</b>	<b>5</b>	At 80~3000 r/min	100	150	40
		At 4000 r/min	90	110	
	<b>10, 15, 20</b>	At 80~3000 r/min	150	200	
		At 4000 r/min	130	170	
	<b>30, 50, 100, 200</b>	At 80~3000 r/min	200	300	
		At 4000 r/min	180	230	
<b>BMU460</b>	<b>5</b>	At 80~3000 r/min	200	250	100
		At 4000 r/min	180	220	
	<b>10, 15, 20</b>	At 80~3000 r/min	300	350	
		At 4000 r/min	270	330	
	<b>30, 50, 100, 200</b>	At 80~3000 r/min	450	550	
		At 4000 r/min	420	500	
<b>BMU5120</b>	<b>5</b>	At 80~3000 r/min	300	400	150
		At 4000 r/min	230	300	
	<b>10, 15, 20</b>	At 80~3000 r/min	400	500	
		At 4000 r/min	370	430	
	<b>30, 50, 100, 200</b>	At 80~3000 r/min	500	650	
		At 4000 r/min	450	550	

### Round Shaft Type

Product Name	Permissible Radial Load		Permissible Axial Load
	10 mm from output shaft end N	20 mm from output shaft end N	
<b>BMU230</b>	80	100	Half of motor mass or less
<b>BMU260</b>	80	100	
<b>BMU5120</b>	150	170	

## Permissible Load Inertia J of Combination Types

### Combination Type – Parallel Shaft Gearhead

Unit:  $\times 10^{-4}$  kg-m<sup>2</sup>

Product Name	Gear Ratio	<b>5</b>	<b>10</b>	<b>15</b>	<b>20</b>	<b>30</b>	<b>50</b>	<b>100</b>	<b>200</b>
		<b>BMU230</b>		12	50	110	200	370	920
<b>BMU230</b>	When instantaneous stop or instantaneous bi-directional operation is performed*	1.55	6.2	14	24.8	55.8	155	155	155
	<b>BMU460</b>		22	95	220	350	800	2200	6200
<b>BMU460</b>	When instantaneous stop or instantaneous bi-directional operation is performed*	5.5	22	49.5	88	198	550	550	550
	<b>BMU5120</b>		45	190	420	700	1600	4500	12000
<b>BMU5120</b>	When instantaneous stop or instantaneous bi-directional operation is performed*	25	100	225	400	900	2500	2500	2500

\*It is also applicable when digitally setting the deceleration time to below 0.1 second.

## Dimensions (Unit mm)

● A number indicating the gear ratio is specified in the box □ in the product name.

For motors with a degree of protection of IP65 specification, **P** is specified where the box ■ appears in the product name.

When the accessory connection cable is supplied, a number indicating the length of the cable, **-1** (1 m), **-2** (2 m), or **-3** (3 m), is specified in the box ◇ in the product name.

### 30 W

#### ◇ Motor/Parallel Shaft Gearhead

Product Name	Motor Product Name	Gearhead Model	Gear Ratio	L	Mass kg
<b>BMU230A</b> ■-□◇ <b>BMU230C</b> ■-□◇	BLM230■-GFV	GFV2G□	<b>5~20</b>	34	0.92
			<b>30~100</b>	38	
			<b>200</b>	43	

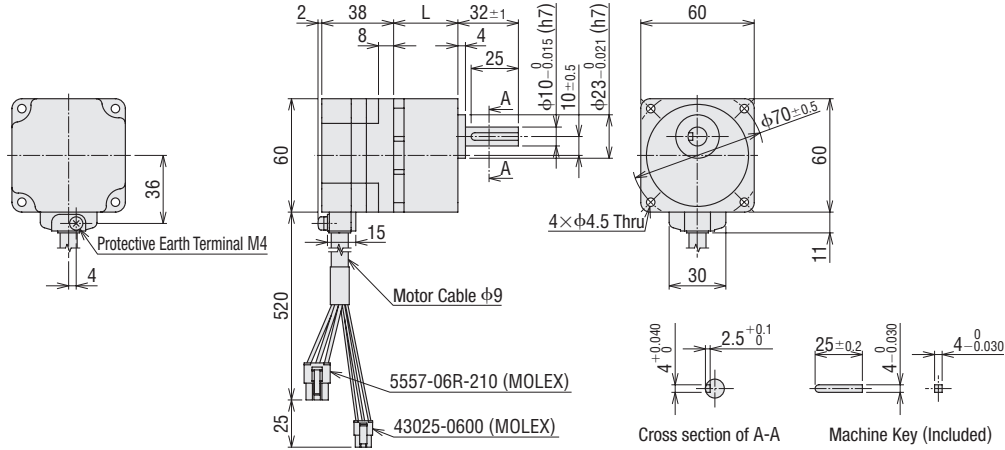

#### ◇ Round Shaft Type

**BMU230A**■-A◇, **BMU230C**■-A◇

Motor: BLM230■-A

Mass: 0.42 kg

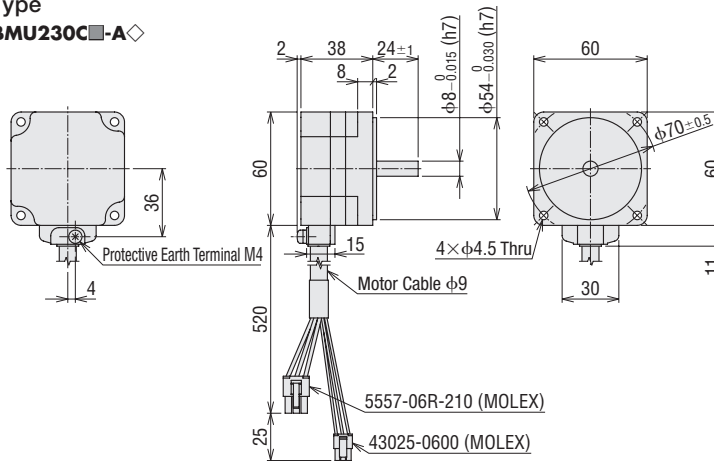

### 60 W

#### ◇ Motor/Parallel Shaft Gearhead

Product Name	Motor Product Name	Gearhead Product Name	Gear Ratio	L	Mass kg
<b>BMU460SA</b> ■-□◇ <b>BMU460SC</b> ■-□◇	BLM460S■-GFV	GFV4G□	<b>5~20</b>	41	1.6
			<b>30~100</b>	46	
			<b>200</b>	51	

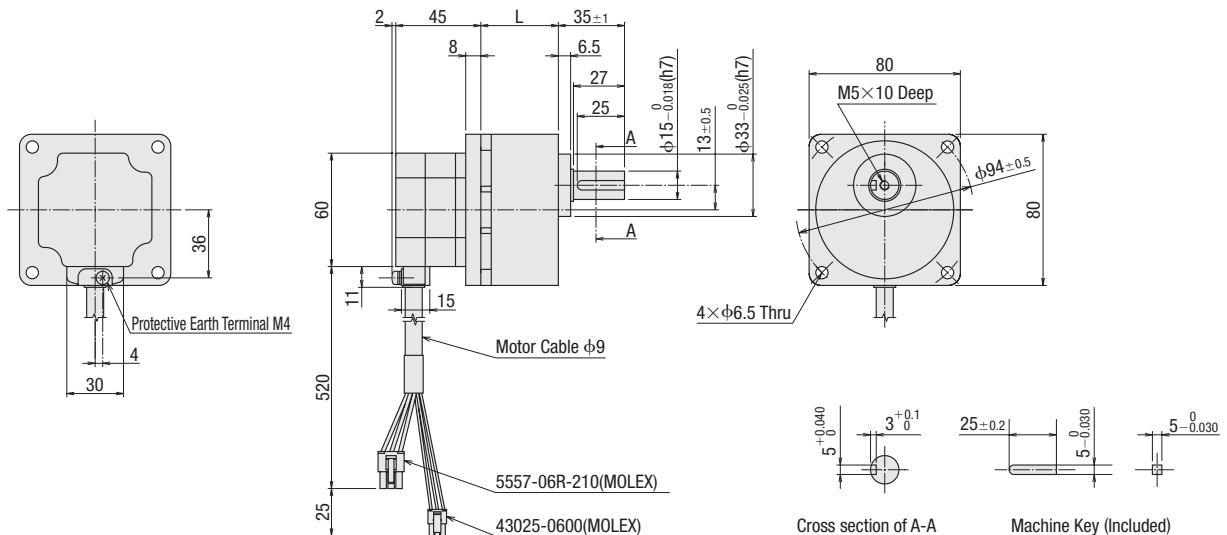

◇ Round Shaft Type

**BMU260A**■-A◇, **BMU260C**■-A◇

Motor: BLM260■-A

Mass: 0.55 kg

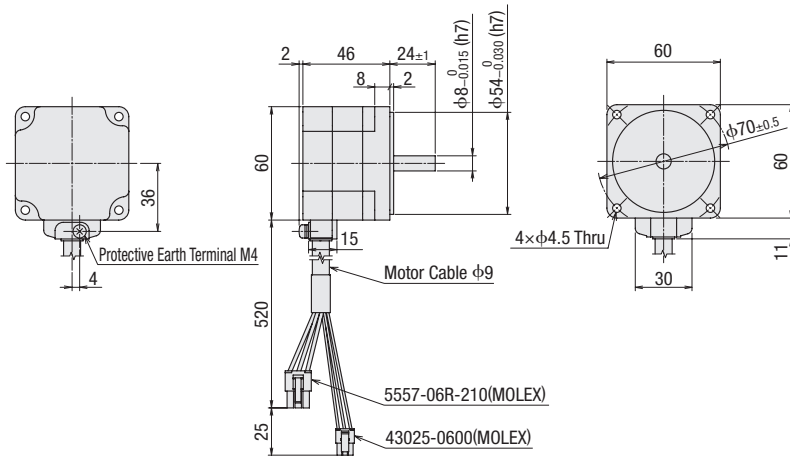

● 120 W

◇ Motor/Parallel Shaft Gearhead

Product Name	Motor Product Name	Gearhead Product Name	Gear Ratio	L	Mass kg
<b>BMU5120A</b> ■-□◇ <b>BMU5120C</b> ■-□◇	BLM5120■-GFV	GFV5G□	<b>5~20</b>	45	2.7
			<b>30~100</b>	58	
			<b>200</b>	64	

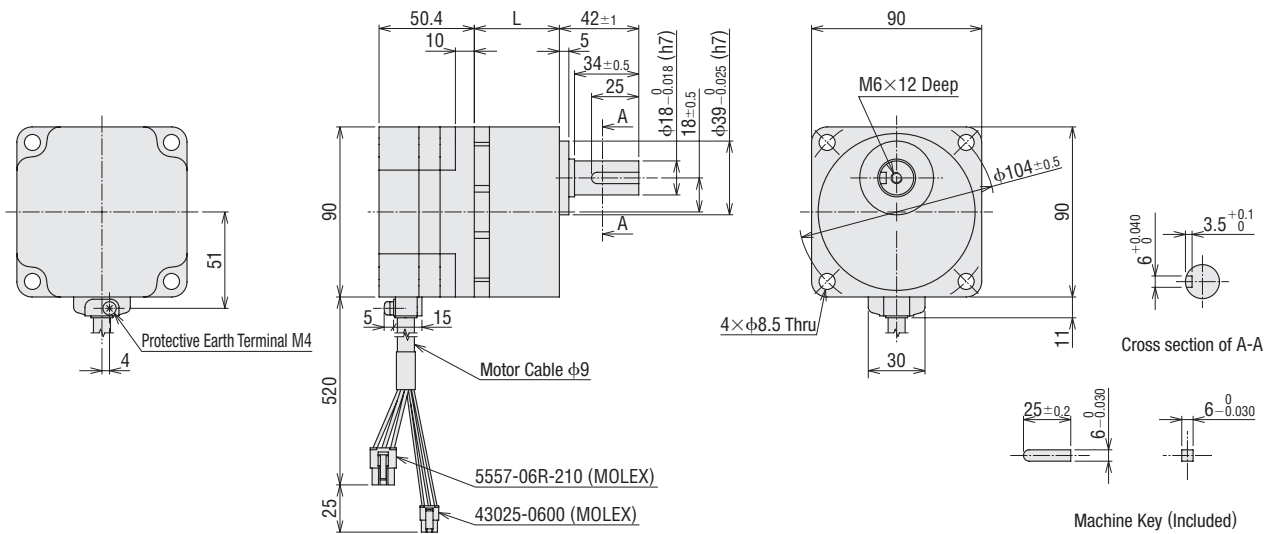

◇ Round Shaft Type

**BMU5120A**■-A◇, **BMU5120C**■-A◇

Motor: BLM5120■-A

Mass: 1.2 kg

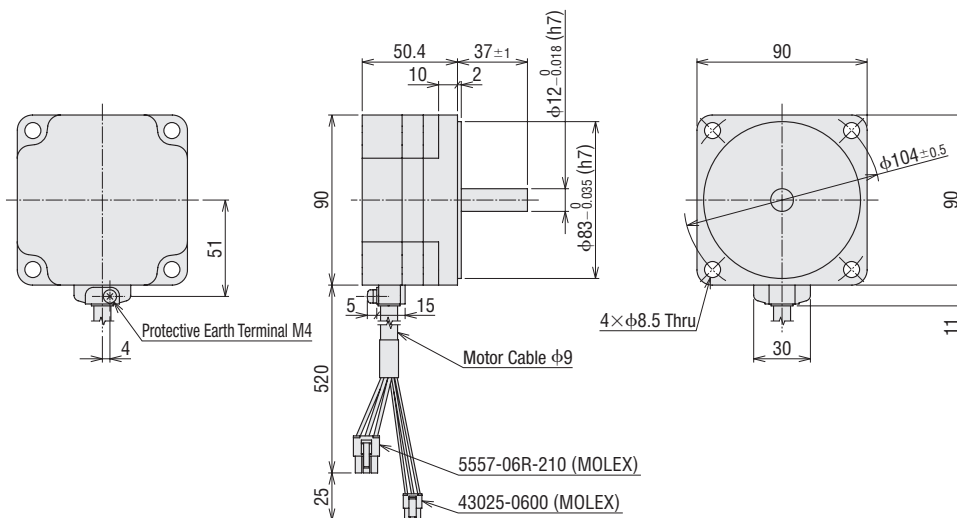

## Driver

BMUD30-A, BMUD30-C, BMUD60-A, BMUD60-C, BMUD120-A, BMUD120-C

Mass: 0.4 kg

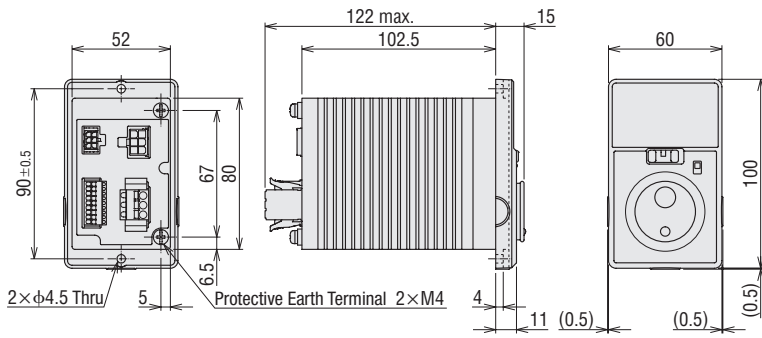

## ◇ Driver Panel Cut-out Diagram

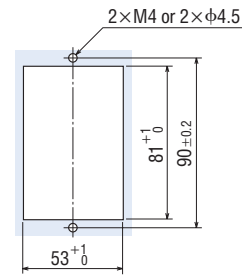

## ● Connection Cable (Included)

Cable Type	Length L (m)
1 m	1
2 m	2
3 m	3

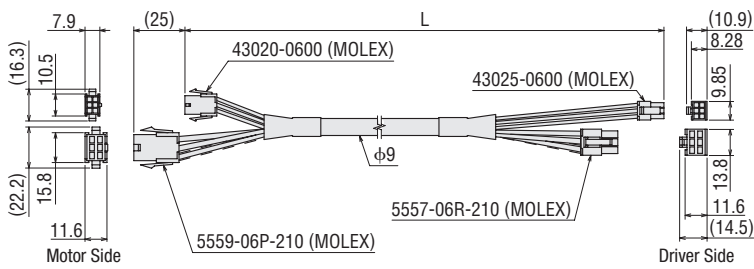

## ■ Dimensions of Installation Screw

### ● Combination Type – Parallel Shaft Gearhead

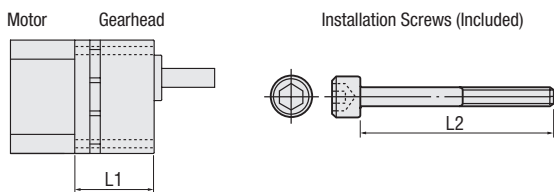

Gearhead Product Name	L1		L2		Screw Size
	Length (mm)	Length (mm)	Length (mm)	Length (mm)	
GFV2G5~20	42	50			M4 P0.7
GFV2G30~100	46	55			
GFV2G200	51	60			
GFV4G5~20	49	60			M6 P1.0
GFV4G30~100	54	65			
GFV4G200	59	70			
GFV5G5~20	55	70			M8 P1.25
GFV5G30~100	68	85			
GFV5G200	74	90			

● Installation screw: Includes 4 plain washers and 4 spring washers each

# Connection and Operation

## Names and Functions of Driver Parts

### Indication

Displays the monitor contents, alarm, etc.

### Dial

Changes the speed and parameters.  
The value is set when the dial is pressed after changes are made.

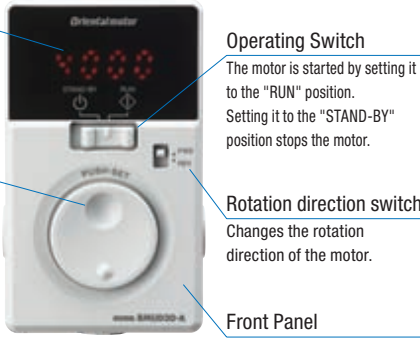

<Front side of the driver>

### Sensor Connector (CN3)

Connects to the signal connector of the motor.

### I/O Signal Connector (CN4)

Connects with the I/O signals.

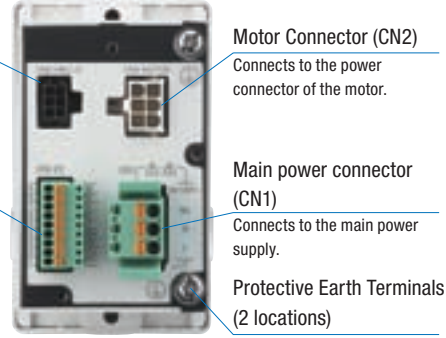

<Back side of the driver>

## When Front Panel is Removed

### MODE Key

Changes the operating mode.

### FUNCTION Key

Changes the indication and functions for the operating mode.

### Acceleration/deceleration time potentiometer

Sets the acceleration time for starting the motor and deceleration time for motor standstill.  
Setting range: 0.1 s ~ 15.0 s

### Installation holes (2 places)



## Extended Functions

Remove the front panel to be able to perform various settings by operating the keys.

Operating mode	Details
Monitoring	Speed, load factor, operating data number, alarm, warning, I/O monitor
Data	Data No. 0, No. 1 (2 points) Operating speed, acceleration time, deceleration time, reset
Parameters	Gear ratio, speed increasing ratio, initial panel indication, initial operation inhibition alarm, initial operation inhibition alarm reset selection, analog acceleration/deceleration, external operating signal input, input function selection, output function selection, overload alarm detection time except during axial lock, overload warning level, speed attainment width, simple holding selection, max./min. speed setting function, parameter mode reset

## Main power connector (CN1)

Connects to the main power supply. Connect a power supply that matches with the power supply voltage to be used.

- Single-Phase 100-120 VAC
- Single-Phase 200-240 VAC
- Three-Phase 200-240 VAC

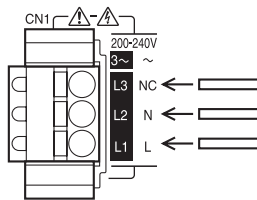
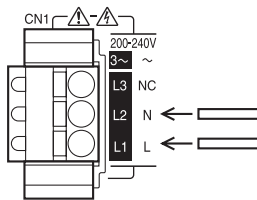
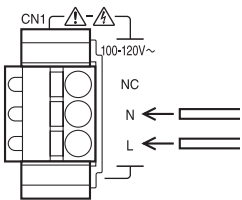

## Applicable Lead Wire Size

AWG18~14 (0.75~2.0 mm<sup>2</sup>)

## Applicable Crimp Terminals

Use the following terminals for connection using crimp terminals. Please note that the applicable crimp terminal varies depending on the size of the lead wire.

Manufacturer	PHOENIX CONTACT	
Product No.	AI 0.75-10	[AWG18 (0.75 mm <sup>2</sup> )]
	AI 1-10	[AWG18 (0.75 mm <sup>2</sup> )]
	AI 1.5-10	[AWG16 (1.25 mm <sup>2</sup> )]
	AI 2.5-10	[AWG14 (2.0 mm <sup>2</sup> )]

## Operation with the driver only

### Run/Stop

When the operating switch is set to the "RUN" position, the motor will start. When it is returned to the "STAND-BY" position, the motor decelerates to a stop.

### Speed Setting Method

Set the motor speed by using the dial.  
Setting range: 80~4000 r/min

Turning the dial slowly to the right increases the speed by 1 r/min increments, while turning it to the left reduces the speed by 1 r/min increments.

Turning the dial fast produces a great variation in speed.

Pressing the dial sets the speed.



Operation with the operating switch

Setting the speed with the dial

## Operating Switch





## ● Operation by external signals

### ◇ Operating Method

- Using the built-in power supply in the driver, the motor is operated through signals from external sources (switches, relays, etc.).  
Connect Pins No. 5~8 of the I/O signal connector (CN4) as in the figure to the right.
- When operating using external signals, change the parameter setting in the "External Operating Signal Input" to "on: Activated", and set the operating switch to the "RUN" position.

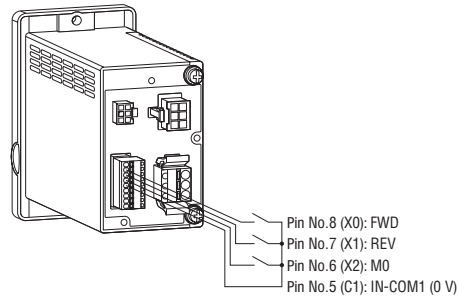

### ● I/O Signals Connector (CN4)

Pin No.	Terminal Name	Signal Name	Description
9	C0	IN-COM0	Input signal common
8	X0	FWD*	The motor rotates in the FWD direction.
7	X1	REV*	The motor rotates in the REV direction.
6	X2	M0*	Select the operating data.
5	C1	IN-COM1	Input signal common (0 V)
4	Y0+	SPEED-OUT*	For every rotation of the motor, 30 pulses are output.
3	Y0-		
2	Y1+	ALARM-OUT1*	It turns OFF when an alarm is generated. (Normally closed)
1	Y1-		

\*These are initial settings. The allocation of values can be changed with the parameters.

### ◇ Timing Chart

This is a timing chart when operated via external signals.  
The rotation direction switch is set to "FWD".

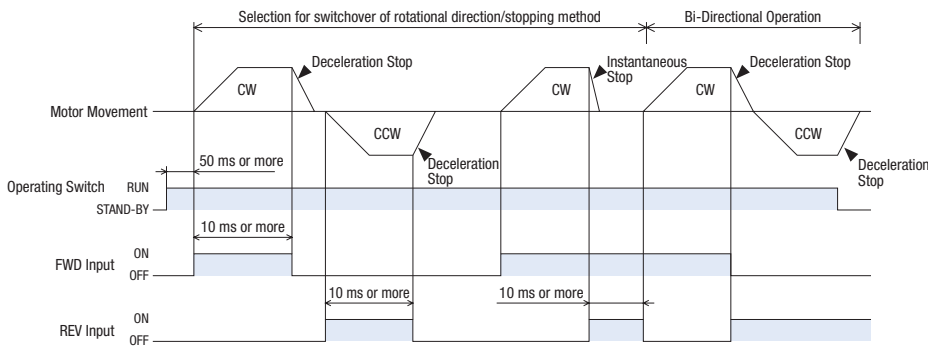

- Switching the FWD input to ON will cause the motor to turn clockwise as viewed from the motor shaft side, while switching the REV input to ON will cause the motor to turn counterclockwise. Turning it OFF decelerates the motor to a stop. If both the FWD input and REV input are turned ON simultaneously, the motor will stop instantaneously.

- With the combination type, the rotation direction varies according to the gear ratio of the gearhead.

### ◇ Connection Diagram

The figure shows an example for a motor operated with sequence connection by a single-phase 100-120 VAC input-type transistor.

#### ● Sink Logic

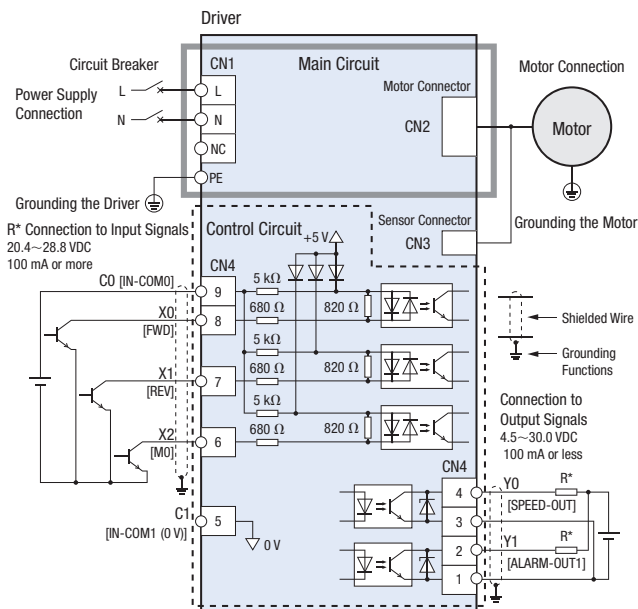

#### ● Source Logic

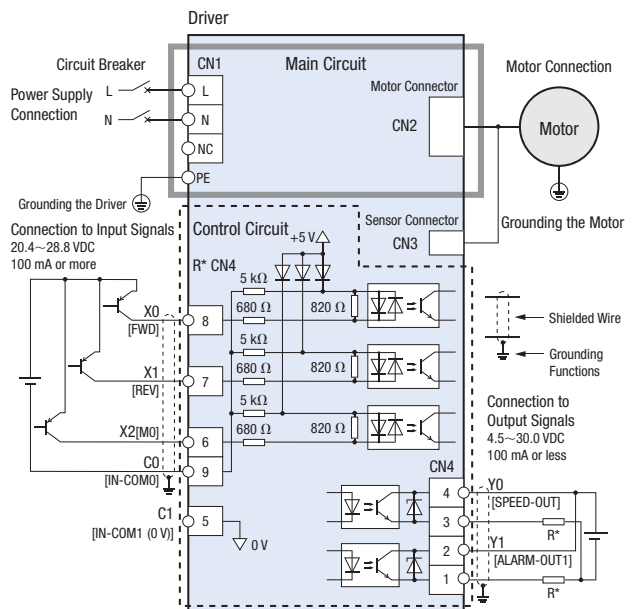

\* Connect a limiting resistor R that corresponds to the power supply used, so that the current that flows with the output signals does not exceed 100 mA.

Recommended limiting resistor R  
 24 VDC: 680 Ω ~ 2.7 kΩ (2W)  
 5 VDC: 150 Ω ~ 560 Ω (0.5W)

# Accessories (Sold separately) RoHS

## Power Supply Cable, Flexible Connection Cable

These cables are used to connect the motor and driver. The maximum extension length of the connectable cable is 10 m.

Use the flexible connection cable in applications where the cable is bent and flexed.



Connection Cable  
Flexible Connection Cables

### Cable System Configuration

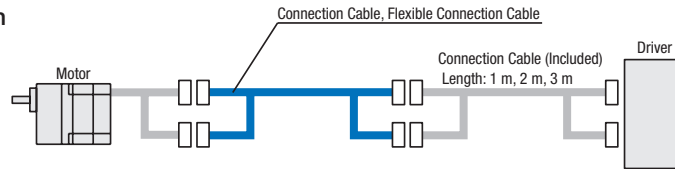

### Product Line

#### Power Supply Cable

Product Name	Power Supply Voltage	Length L (m)
<b>CC01AC03N</b>	Single-Phase 100-120 VAC	1
<b>CC02AC03N</b>	Single-Phase 200-240 VAC	2
<b>CC03AC03N</b>	Single-Phase 200-240 VAC	3
<b>CC01AC04N</b>	Three-Phase 200-240 VAC	1
<b>CC02AC04N</b>		2
<b>CC03AC04N</b>		3

### Dimensions (Unit mm)

#### •CC01AC03N, CC02AC03N, CC03AC03N

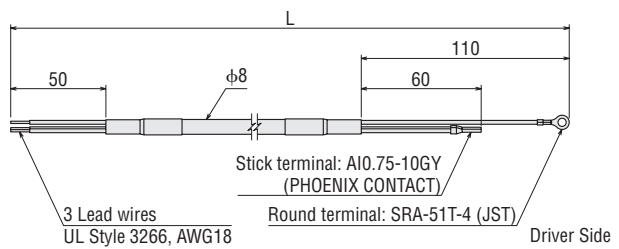

#### •CC01AC04N, CC02AC04N, CC03AC04N

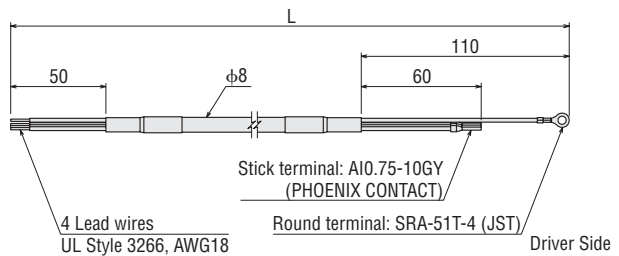

#### Connection Cable

Product Name	Length L (m)
<b>CC01BLE</b>	1
<b>CC02BLE</b>	2
<b>CC03BLE</b>	3
<b>CC05BLE</b>	5
<b>CC07BLE</b>	7
<b>CC10BLE</b>	10

#### Flexible Connection Cables

Product Name	Length L (m)
<b>CC01BLER</b>	1
<b>CC02BLER</b>	2
<b>CC03BLER</b>	3
<b>CC05BLER</b>	5
<b>CC07BLER</b>	7
<b>CC10BLER</b>	10

#### Connection Cable, Flexible Connection Cables

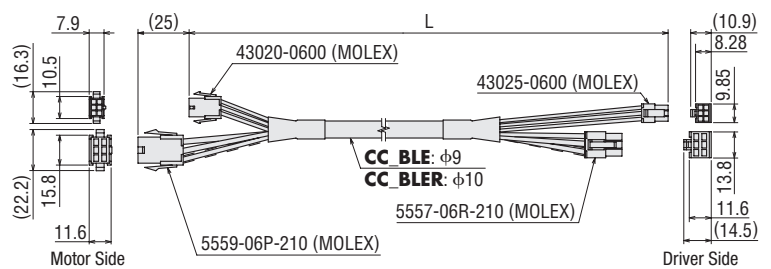

## Motor and Gearhead Mounting Bracket

These dedicated mounting brackets are for mounting motors and gearheads.

### Dimensions (Unit mm)

#### SOL2M4F

Mass: 140 g

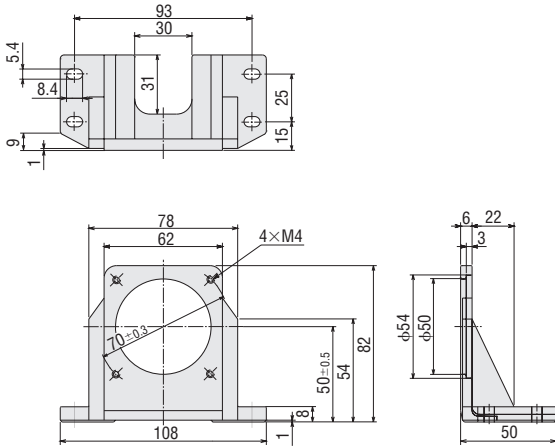

#### SOL5M8F

Mass: 280 g

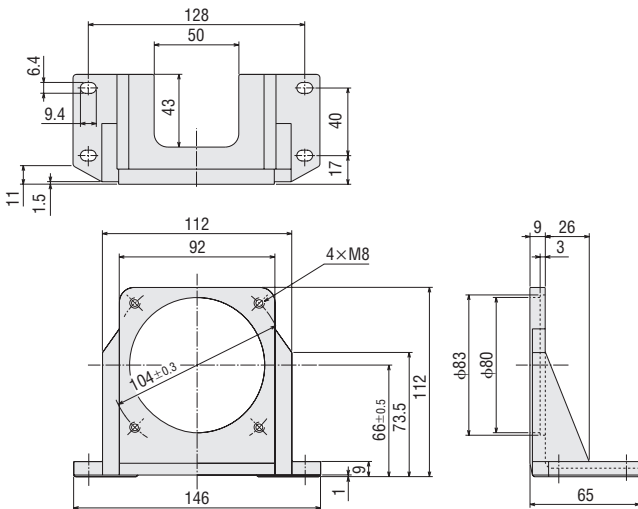

### Product Line

Product Name	Applicable Product
<b>SOL2M4F</b>	<b>BMU230, BMU260</b>
<b>SOL4M6F</b>	<b>BMU460</b>
<b>SOL5M8F</b>	<b>BMU5120</b>

#### SOL4M6F

Mass: 210 g

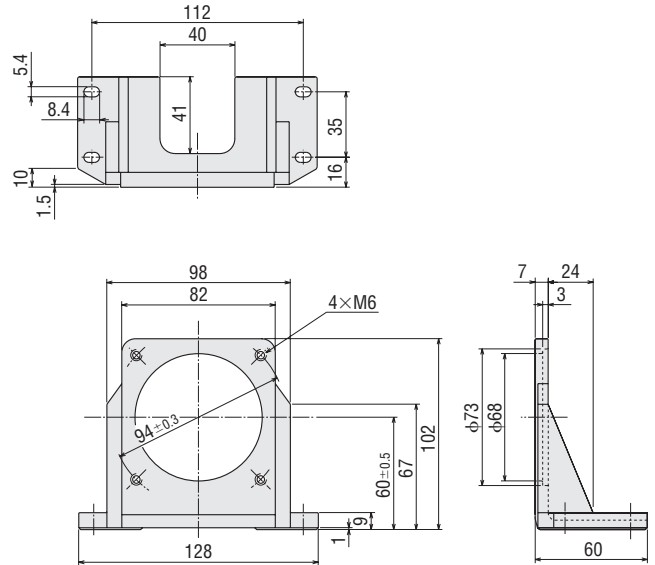

## Circuit products mounting brackets

Mounting brackets for installing the driver are available.

Mounting brackets have product lines for different applications such as for DIN rail installation, installation on the wall surface, and for conveyor guide installation.

### Product Line

Material: SPCC Surface treatment: Trivalent chromate

Product Name	Application
<b>MADP05-15</b>	For DIN Rail Installation
<b>MAFP04-15</b>	For Wall Surface Installation
<b>MAFP05V</b>	For Conveyor Guide Installation
<b>MAFP05H</b>	

For details, check the Oriental Motor website or contact the Oriental Motor sales office.

<http://www.orientalmotor.eu>



**MADP05-15** <Application example>



**MAFP04-15** <Application example>



**MAFP05V** <Application example>



**MAFP05H** <Application example>

## Flexible Couplings

These are clamp type couplings for connecting the motor/gearhead shaft with the driven shaft.

Couplings usable for the combination type and the round shaft type are available.



### Product Line

Product Name	Applicable Product
<b>MCL30</b> Type	<b>BMU230</b> Combination Type
<b>MCL40</b> Type	<b>BMU460</b> Combination Type
<b>MCL55</b> Type	<b>BMU5120</b> Combination Type

For details, check the Oriental Motors website or contact the Oriental Motor sales office.

<http://www.orientalmotor.eu>

# Orientalmotor

These products are manufactured at plants certified with the international standards **ISO 9001** (for quality assurance) and **ISO 14001** (for systems of environmental management).

Specifications are subject to change without notice.  
Published in December 2013.

#### ORIENTAL MOTOR (EUROPA) GmbH

[www.orientalmotor.de](http://www.orientalmotor.de)

European Headquarters and Düsseldorf Office  
Schiessstraße 74  
40549 Düsseldorf, Germany  
Tel:0211-5206700 Fax: 0211-52067099



#### For other countries - EU-Webshop:

[www.orientalmotor.eu](http://www.orientalmotor.eu)



#### ORIENTAL MOTOR (UK) LTD.

[www.oriental-motor.co.uk](http://www.oriental-motor.co.uk)

Unit 5, Faraday Office Park,  
Rankine Road, Basingstoke,  
Hampshire RG24 8AH, U.K.  
Tel:01256-347090 Fax:01256-347099



#### ORIENTAL MOTOR (FRANCE) SARL

[www.orientalmotor.fr](http://www.orientalmotor.fr)

France Headquarters  
56, Rue des Hautes Pâtures  
92000 Nanterre Cedex, France  
Tel: 01 47 86 97 50 Fax: 01 47 82 45 16



#### ORIENTAL MOTOR ITALIA s.r.l.

[www.orientalmotor.it](http://www.orientalmotor.it)

Italy Headquarters  
Via A. De Gasperi, 85  
20017 Mazzo di Rho (MI), Italy  
Tel: 02-93906346 Fax:02-93906348



#### ORIENTAL MOTOR CO., LTD.

[www.orientalmotor.co.jp](http://www.orientalmotor.co.jp)

Headquarters  
16-17, Ueno 6-chome  
Taito-ku, Tokyo 110-8536, Japan  
Tel: (03)3835-0684 Fax: (03)3835-1890

### Customer Center (Support in German & English)

00800 - 22 55 66 22\*  
CA LL OM CC

Mon-Thu: 08:00 - 17:30 CET

Friday: 08:00 - 16:00 CET

\* Free Call Europe

[info@orientalmotor.de](mailto:info@orientalmotor.de)

© Copyright Oriental Motor (Europa) GmbH 2013  
UK/122013/VERS01

Printed in December 2013