

Autobag® 500™ Bagging Machine – The flagship in bag packaging machinery

The Autobag® 500™ bagger is a technologically-advanced, automatic filling and sealing machine designed for reliability, flexibility and optimising packaging throughput. Capable of cycling at rates over 100 bags per minute, this system was designed to maximise machine uptime while lowering total cost of ownership.

State-of-the-art engineering has led to an innovative, inherently safe design. No light curtains or bulky guarding are required to achieve safe operation for hand load applications. This revolutionary new approach provides unobstructed access to the open bag, facilitating faster, more ergonomic loading.

The system features a simple design with very few moving parts, reducing lifetime cost and improving uptime. Servo driven web controls along with job storage capabilities reduce the amount of bags in queue, eliminating waste and decreasing changeover time.

Capable of being configured for left or right-hand access to the HMI, cycle switch, bag loading, and ribbon loading provides seamless integration into any operation. The system can also be networked for full pack station integration to facilitate central monitoring; and the extraction of productivity information that can be manipulated for detailed analysis.

When used with genuine Autobag pre-opened bags-on-a-roll, the Autobag 500 ushers in the next evolution of high-quality, reliable and flexible bag packaging, backed by the industry's most comprehensive engineering and field service network.

Markets Served

- Aerospace & Defence
- Automotive
- Electronics
- Hardware & Fasteners
- Healthcare
- Hobby & Craft
- Household Products
- Cosmetics
- Pet Products
- Plumbing Parts



Easily integrates with inline printers, counters, scales, and conveyors for semi to fully automatic bagging



Modular components and dedicated service access simplify maintenance and repairs to maximise uptime



AutoTouch™ Control Screen accesses operator tutorials, help system, on-board diagnostics, and performance monitoring



Multi-position unwind with tension control simplify changeover

Features and Benefits

More Options

More bag size options; from 50mm W x 65mm L to 300mm W x 550mm L supported (914mm long unsupported)

Streamlined

Processor controlled servo motors, Ethernet-capable networking, and flexible mechanical design streamline integration

Compact

Compact footprint minimises floor space

Adjustable

Simple height adjustment and casters for operator comfort and portability

Flexible

Adjustable pass-through up to 125mm for maximum flexibility and packaging efficiency



Convertible

Easily converts from vertical to horizontal load to accommodate a wide variety of products



Ensures Consistent Quality

Newly designed bag sealer area combined with improved temperature control and optional seal-flatteners ensure consistent, high-quality seals



Optional Additions

- Range of In-Feed Funnels
- Seal Flatteners
- Raised Unwind
- SimpleCount™ Counting System
- Product Load Tray

Technical Information

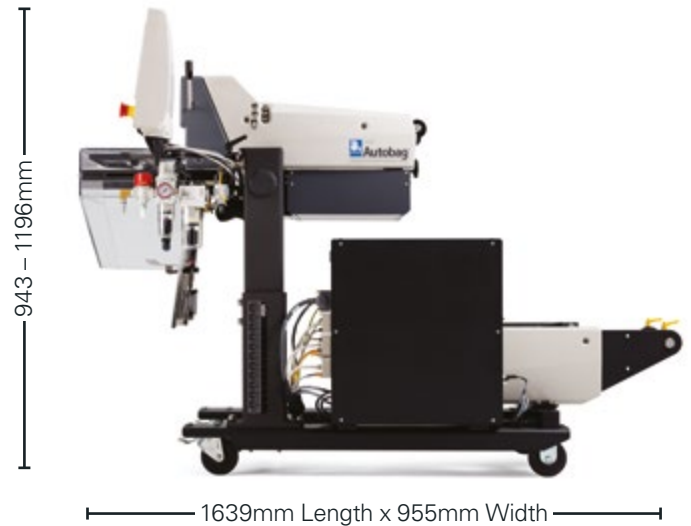

Weight	158kg
Electrical	Universal Input: 110V to 240V VAC, 50/60 Hz Power Consumption: 1500 Watts (VA) max
Air Feed	5 CFM/80 psi of clean, dry air
Pass-Through	125mm max
Bag Thickness	35 to 100µm
Bag Sizes	W 50 to 300mm L* 65 to 550mm <small>*There are two versions, Long and Short. Long configuration min length is 130mm. Short min length is 63mm.</small>
Weight Capacity	Up to 2.2kg (with load shelf)



System Matched Bags



Service & Support



Custom Engineering & Integration

☎ 01684 891 400 ✉ sales@autobag.co.uk 🌐 autobag.co.uk

🏠 Automated Packaging Systems, Enigma Business Park, Sandy's Road, Malvern, WR14 1JJ

© Jan 2016 Automated Packaging Systems. Features, Options & Technical Specifications subject to change. The use of the ® or ™ symbol indicates that Automated Packaging Systems, Inc. has registered or is otherwise claiming trademark rights in the United States. These marks may also be registered in other countries and common law rights may apply in countries where such rights are recognized. 01/16 2.5M