

ISO valve terminal VTSA – maximum functionality

FESTO

Communicative
and safe!

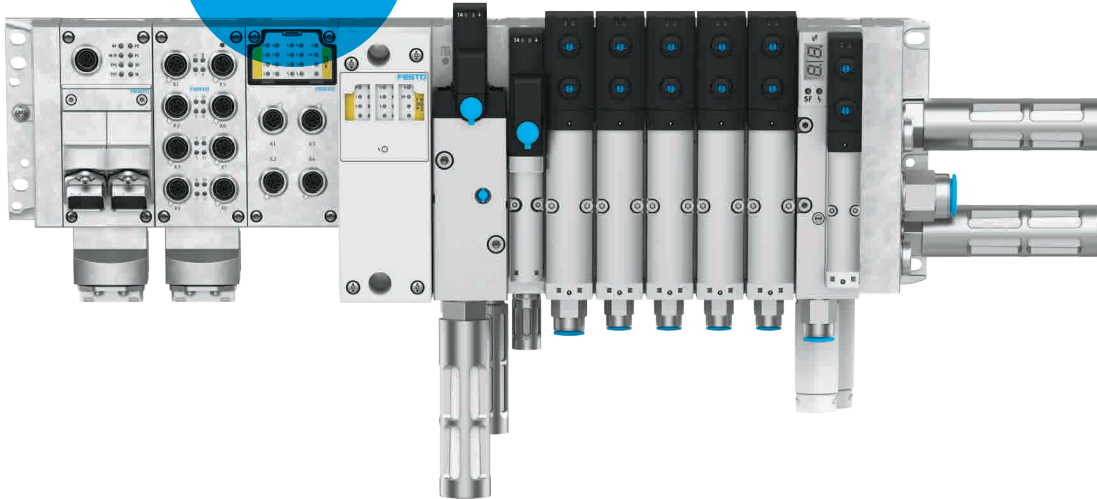

High flow rate!

Highlights

- **New:** Serial communication with VTSA-F-CB
- Maximum function integration
- Very high flow rate – up to 4,000 l/min
- 5 valve sizes on one terminal, up to size 2 without an adapter
- Certifications: UL, CSA, CE, C-Tick, IFA
- Valve replacement during operation (hot swap)
- Reverse operation of valves and pressure regulators
- Vacuum generator
- Pressure zones
- Diagnostic concept
- Vertical stacking
- Safety@Festo, PROFIsafe

The VTSA is ideal for maximum pneumatic and electrical function integration. And the mix of 5 valve sizes on one valve terminal is unique! The VTSA is fully compliant with ISO 15407-2 and ISO 5599-2 yet is easy to integrate. It can also be used as a complete installation solution for large-scale machine concepts. Optimised for flow rate: VTSA-F. Optimised for communication: VTSA-F-CB.

Versatile and easy electrical installation

The terminal CPX can be used with all common fieldbus systems or Ethernet. It also has an integrated diagnostics concept.

Integrated safety

Thanks to intelligently combined standard components and safety valves, the requirements of ISO 13894-1 and the EU Machinery Directive are easily fulfilled.

Total process safety

It can even be used in harsh environments: the sturdy metal housing, completely sealed valves, as well as the ducted exhaust air and pilot air protect against failure in fine dust environments.

Communicative

Serial communication for significantly more applications: the internal bus system provides 96 valve addresses and up to 4 voltage zones, of which 3 can be safely disconnected. Added to this are even more high-performance modules like the new soft-start valve or the integrated vacuum generator for VTSA-F-CB.

Cost-efficient

Having five valve sizes on one valve terminal together with the modular system saves energy costs and money, because the required flow rate can be better adjusted per valve position.

Standardisation at its best – integrated communication and safety

Function integration for maximum efficiency

It's all thanks to function integration: never before has an ISO valve terminal offered such a degree of flexibility. The sturdy, highly adaptable and modular design of the VTSA makes it very popular with the automotive industry. It is also well thought of by many other industry segments that prefer standardised products and high flow rates yet also require high flexibility and modularity. Both the VTSA-F with its optimised flow rates and maximum output, and the VTSA safety functions contribute to this success, while the VTSA-F-CB with serial communication is new to the range. That is what Safety@Festo directly in the application is all about. VTSA thus minimises your total cost of ownership (TCO).

Valve terminal VTSA – overview of functions

Tip for fine dust environments

Easy valve conversion!
Simply turn the valve seal for ducted exhaust air/pilot air. The valves can then be used in fine dust environments.

- Sub-base valve
- Manual pressure regulator plate
- Throttle plate
- Vertical supply plate
- Vertical pressure shut-off plate

CPX diagnostic interface: channel-oriented diagnostics down to the individual valve with the Festo Maintenance Tool.

New: VTSA-F-CB with different variants for the pneumatic interface, e.g. the integrated PROFIsafe module and the other option of creating 3 external safe voltage zones

Safe to operate with the manual overrides: non-detenting/detenting, covered or non-detenting/sturdy

Safety@Festo: pilot air switching valve size 02, 18 mm

Vacuum generator

Safety@Festo: 5/2 safety control block

Safety@Festo: soft-start valve VABF-S6

M12 individual connection

Pneumatic interface to CPX

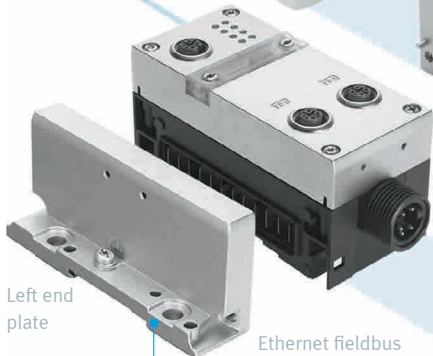
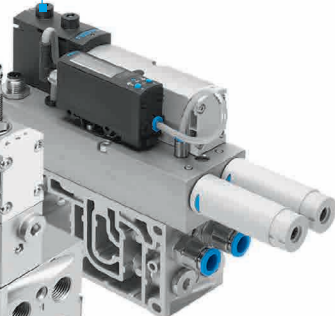
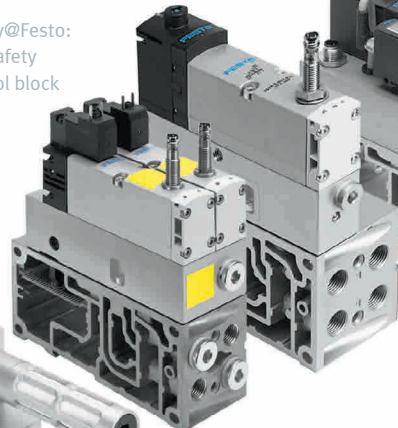
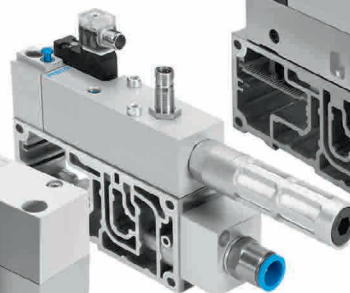
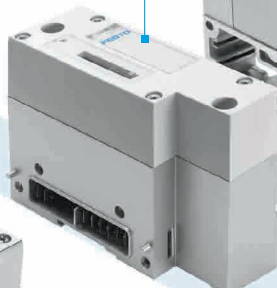

Ethernet fieldbus node, metal/polymer, M12 connection

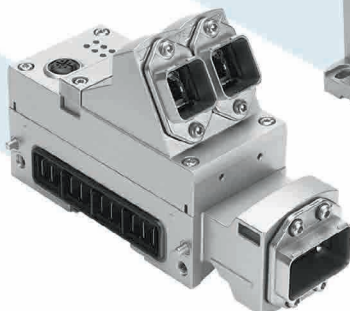

Ethernet fieldbus node, metal, AIDA compliant with push/pull plug

Left end plate

Quick to assemble using screws or H-rail

Multi-pin node

- Quick and easy to connect
- M12 individual connection
 - Multi-pin plug connection
 - Fieldbus interface
 - Integrated controller (front-end controller)
 - AS-Interface

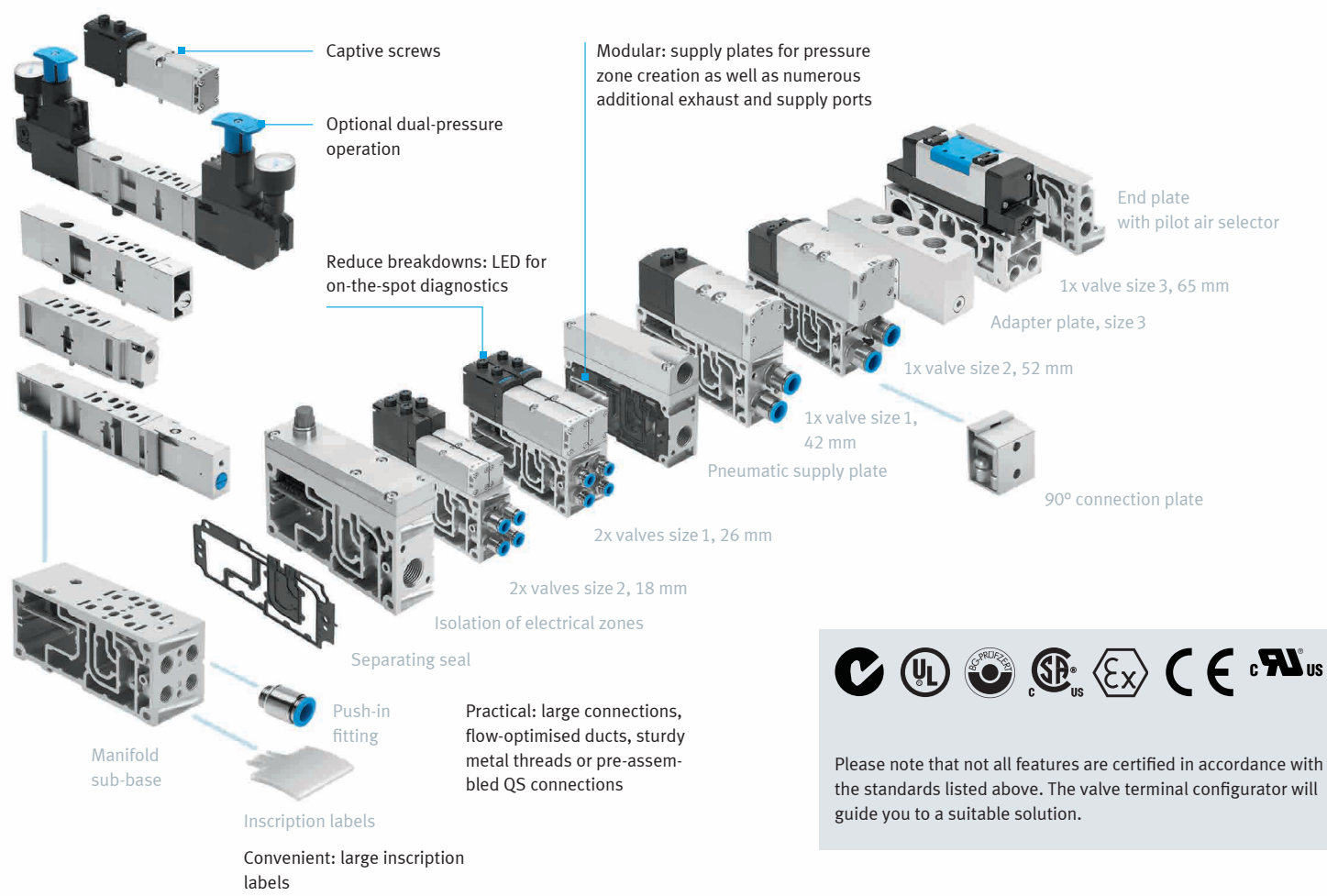

Please note that not all features are certified in accordance with the standards listed above. The valve terminal configurator will guide you to a suitable solution.

Pneumatics – VTSA	ISO 15407-2		ISO 5599-2		
Valve functions	5/2, 5/3, 2x3/2, 2x2/2, special functions			5/2, 5/3	
Manual override	Non-detenting/detenting, non-detenting/sturdy, covered			Non-detenting	
Design	Piston spool valve				
Number of valve positions	VTSA /VTSA-F: max. 32 valve addresses (solenoid coils) VTSA-F-CB: max. 96 valve addresses via 4 zones with max. 24 valve addresses (solenoid coils) per zone				
PROFIsafe	VTSA /VTSA-F: external via CPX modules, valves can only be actuated via external cabling. VTSA-F-CB: optionally integrated in the pneumatic interface. 3 zones or 2 zones and an external PROFIsafe output				
Size [mm]	ISO-02 18	ISO-01 26	ISO-1 42	ISO-2 52	ISO-3 65
Flow rate up to					
VTSA [l/min]	550	1100	1300	2900	4000
VTSA-F [l/min]	700	1350	1860	2900	4000
VTSA-F-CB [l/min]	700	1350	1860	2900	–
Working ports ¹⁾	G1/8, 1/8 NPT	G1/4, 1/4 NPT	G3/8, 3/8 NPT	G1/2, 1/2 NPT	G1/2, 1/2 NPT
Supply ports ¹⁾	G 1/2, 1/2 NPT or G3/4, 3/4 NPT			G1, 1 NPT	
Operating pressure [bar]	3 ... 10 (internal pilot air) –0.9 ... 10 (external pilot air)				
Temperature range [°C]	–5 ... 50				

¹⁾ VTSA-F-CB only with G thread. Alternatively, the hybrid fittings can be configured with imperial tubing diameter.

New: Serial communication with VTSA-F-CB for more options

Integrated benefit: serial and parallel communication in the VTSA

VTSA/VTSA-F

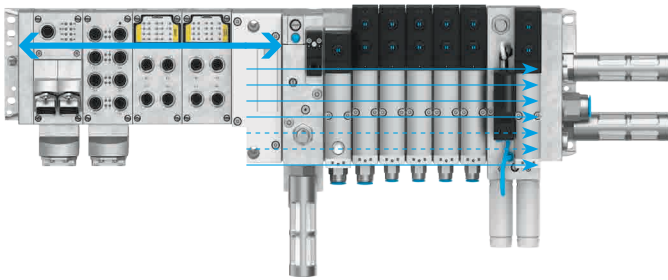

Serial communication: all CPX modules

Parallel communication: all switching valves VTSA

VTSA-F-CB

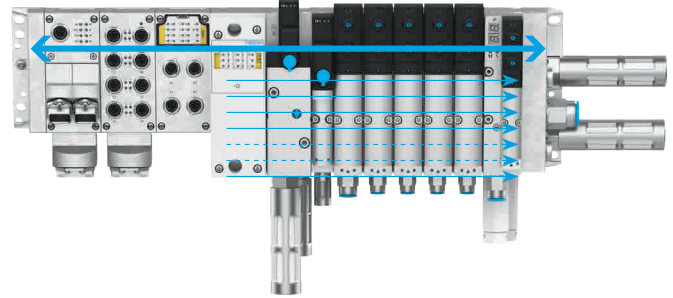

Serial communication: all CPX and selected VTSA modules:

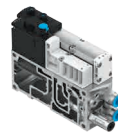

Pressure sensor of the pilot air switching valve

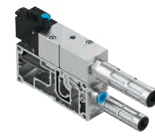

Soft-start/quick exhaust valve



Vacuum generator

Get the benefit of both technologies

Combining the two communication technologies will greatly increase the benefits for you. The serial communication makes the previous external cabling unnecessary while the installation space remains the same. This means fewer additional components and reduced wiring. The address range for the valve positions has also increased. Now up to 96 valves with 4 voltage zones can be actuated. The VTSA/VTSA-F linked in parallel permit a

maximum of 32 valve addresses. If, for example, you used to need 2 valve terminals for 44 valve positions, with the VTSA-F-CB you now only have to have one valve terminal and only one field-bus node.

The serial communication is suitable for the highest bit rates (datasets per time). This provides the VTSA-F-CB modules with new digital properties. For example, by measuring all vacuum times

or comparing them with a homing reference, the new vacuum generator VTSA-F-CB can send warnings about any deviation directly to the machine controller.

The simultaneous and parallel communication of the valves enables you to continue to use all the previous directional control valves with the related components.

Looking ahead, serial communication will make it possible to integrate proportional pressure regulators into the VTSA-F-CB in the future.

VTSA-F-CB: advantages at a glance

- Up to 96 valve addresses via 4 zones through serial communication, up until now a maximum of 32 valve addresses
- PROFIsafe compactly integrated in the pneumatic interface
- Maximum flexibility thanks to various pneumatic interfaces for VTSA-F-CB
- New serial modules can be connected without external cabling
- All the previous directional control valves and related components such as throttle plates can still be used

New function integration options for VTSA-F-CB via serial communication

Previous solution with CPX/VTSA-F

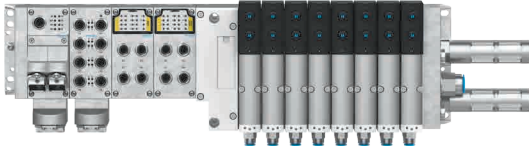

Valve terminal 1 with:

- Fieldbus node
- Two I/O modules
- PROFIsafe output module
- 6x 5/2-way double solenoid valves and 2x 5/3-way valves (max. 32 solenoid coils)



Valve terminal 2 with:

- Fieldbus node
- PROFIsafe output module
- 2x 5/2-way double solenoid valves and 2x 5/3-way valves

Solutions with CPX/ VTSA-F-CB

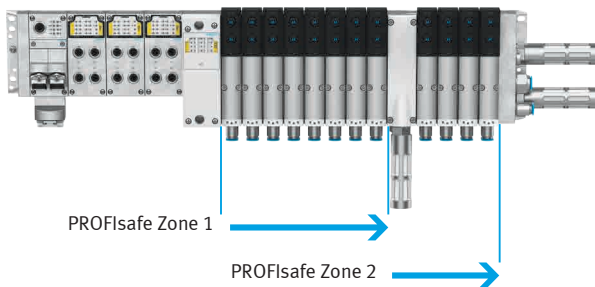

Benefits:

- You save a fieldbus node, a PROFIsafe output module and the external cabling for the controller.
- Very compact design, as only one fieldbus node is needed and the PROFIsafe output module is integrated in the pneumatic interface of the VTSA-F-CB.
- Only one valve terminal and one order code

Pneumatic interface VTSA-F-CB



Pneumatic interface and supply plate for creating pressure zones

With this pneumatic interface as well as all others, the option of coil diagnostics via "back-readable outputs" has now become standard. This means that, when necessary, the diagnostics on a wire break and short circuit can be processed via the process image directly as a bit in the controller.



Pneumatic interface with PROFIsafe for up to 3 zones

You can now safely disconnect up to 3 voltage zones with a maximum of 24 solenoid coils per zone with the PROFIsafe output. This means, for example, that further soft-start/quick exhaust valves can be integrated in one valve terminal with one pressure zone. This is not possible with the VTSA/VTSA-F.



Pneumatic interface with PROFIsafe and an external safe output

If you want to safely disconnect a valve on an individual sub-base directly on the actuator, you can use the external PROFIsafe output on the pneumatic interface. 2 further voltage zones can be created on the valve terminal, and these can be disconnected using PROFIsafe.



Pneumatic interface with external supply voltage

Do not use PROFINET as a bus protocol, but instead use EtherNet/IP with the protocol CIP Safety; you can feed up to 3 safe outputs via this pneumatic interface. Up to 3 safe zones are thus possible with other protocols such as CIP Safety, openSAFETY or FAIL SAFE over EtherNet (FSoE).

Maximum modularity and functionality

A large variety of components and vertical stacking modules

Valve terminal VTSA combined with electrical terminal CPX offers virtually limitless options thanks to maximum modularity and functionality. Reduce your engineering efforts and costs, shorten your ordering processes and accelerate and simplify assembly work. Whether it is for pneumatic or electrical systems, motion control and networking, the terminal CPX from Festo provides extensive functionalities. This makes the VTSA genuinely flexible and modular. VTSA for when you need standardisation to give you real benefits, such as valves and manifold sub-bases with electrical connections in compliance with ISO.

Savings potential

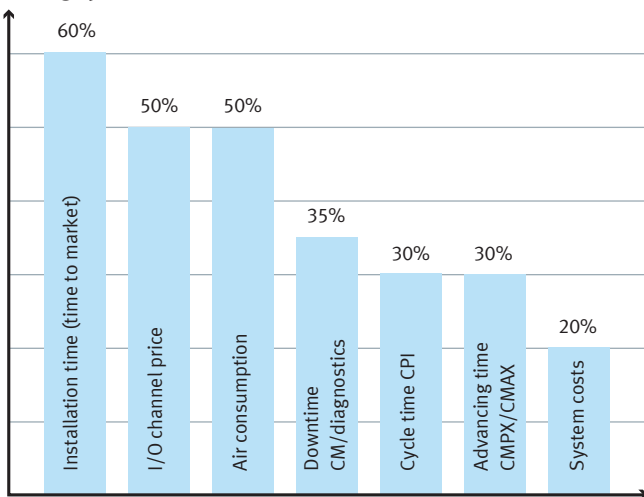

Benefits of the VTSA/CPX

- 5 valve sizes mixed on one valve terminal: no more individual valves for flow rates of 4000 l/min. Having all 5 sizes on the VTSA-F is ideal for an even greater flow rate in the same installation space.
- Vertical stacking for all 5 valve sizes for technically and economically optimised control chains.
- Minimised installation space in the machine and control cabinet and optimised processes thanks to a mix of 5 valve sizes
- Motion package for CPX: measuring modules, positioning modules, parameterisation and control of electric drives, electronic end position control, servo-pneumatic positioning systems, vision systems for object and position detection

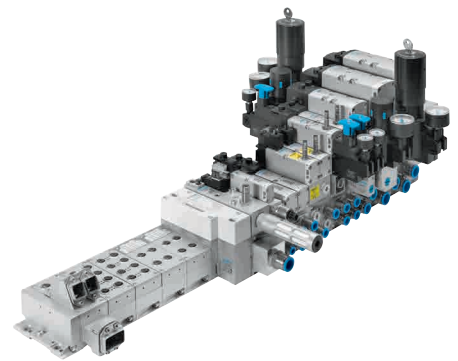

Vertical stacking – sturdy and modular

Complete vertical stacking range for all 5 sizes. Additional modules can be inserted at each valve position between the manifold sub-base and the valve. These modules are referred to as vertical stacking and enable special functions at the individual valve position.

New: you can now mount valve sizes 18 and 26 mm together on one manifold sub-base.



Vertical pressure shut-off plate
Uninterrupted production! Valve replacement under pressure during continuous operation (hot swap).

New: Now also lockable.



Throttle plate
For adjusting the speed of the drive.



Vertical supply plate
For providing an individual operating pressure to a valve position using internal or external auxiliary pilot air, to be connected in addition.

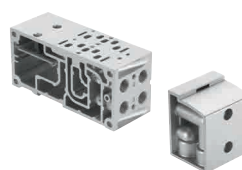

90° connection plate
For alternative working port directions in the control cabinet or for sturdy installations.

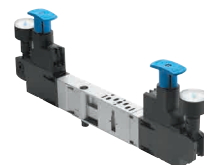

Pressure regulator plate
Ensures a very wide range of pressure and functions! For different pressure levels, separation of channels 1, 2, 4 or 2 – 4.

New: Now also lockable for valve sizes 42/52 mm.

Benefits of the VTSA: reverse and dual-pressure operation

When used cleverly, reverse and dual-pressure operation can save the operator both energy and costs.

The benefits of dual-pressure operation:

- Energy savings of up to 50% by reducing the force for the return stroke, e.g. reversing with 3 instead of 6 bar.
- Compensation of the piston's effective surface area so the advance and return strokes are carried out with the same force
- Only one valve for applications in which the vacuum is to be generated externally and an ejector pulse is required
- 2x3/2-way valves make for a very compact design for different applications or for a single-acting cylinder in dual-pressure operation.

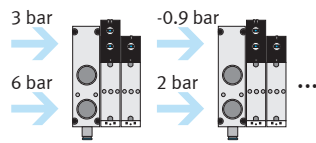

Left: 6 bar for working stroke and 3 bar for return stroke to save energy. Right: -0.9 bar for vacuum and 2 bar for ejector pulses.

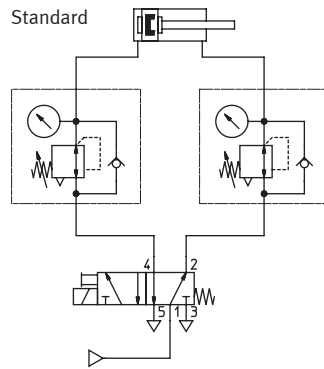

Standard
Pressure is regulated downstream of the valve

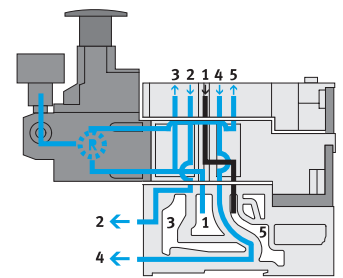

Reverse operation

VTSA valves and complete pressure zones can also be operated in reverse, because the valves are usually reversible and non-overlapping. Exhaust ports 3 and 5 are completely separated for compressed air supply in dual-pressure operation. The exhaust air is not separated and is exhausted through duct 1.

Benefits of pressure regulators operated in reverse:

- Higher exhaust performance
- Up to 50% faster exhaust
- Lower wear on the pressure regulator
- Pressure regulators can be adjusted independently of the valve switching
- Can be adjusted very accurately, perfect for very low operating pressures

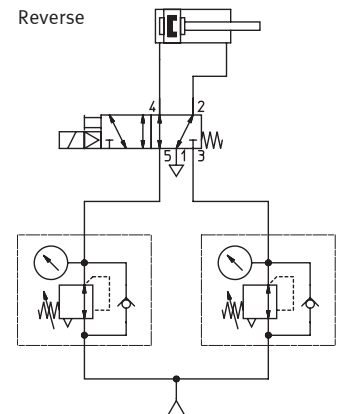

Reverse
Pressure is regulated upstream of the valve

VABF: integrated vacuum function

For greater performance, convenience and safety: the new vacuum block VABF-S4-1-V2B1-C-VH-20 with ejector pulse, vacuum switch and air saving function. The new block provides the VTSA/VTSA-F with all conceivable valve functions including vacuum generation.

Save up to 90% of the compressed air

Thanks to the integrated air saving functions and the controlled switch-on and switch-off of the suction function, you can save more than 90% of the compressed air, depending on the cycle.

Convenient thanks to function integration

The integrated functions of vacuum generation, ejector pulse and air saving function with adjustable pressure sensor make vacuum operation very convenient and also extremely efficient.

New: Even more functions with the vacuum generator actuated in series for the VTSA-F-CB.

The vacuum generator for the VTSA-F-CB no longer needs to be operated using pushbuttons. Parameterisation is carried out directly via the CPX system. New, smart functions have also been added. Thanks to the teach-in functionality, you can set up the homing reference. As all vacuum

times are measured and compared with the homing reference, there are warnings if the pre-set times deviate – another tool to support you with process monitoring and preventative maintenance. It is also possible to change the vacuum limits per dataset; format change-overs on the system are thus digital.

In addition, the new vacuum generators for the VTSA-F-CB facilitate greater process safety. You can block the ejector pulse if a safety function is requested or if an error occurs, e.g. in the case of undervoltage.

Other additions include the air saving function with emergency off, the "Power ejector pulse" option for even shorter

process times and the selection of vacuum types: H for high negative pressure or L for a high suction rate.

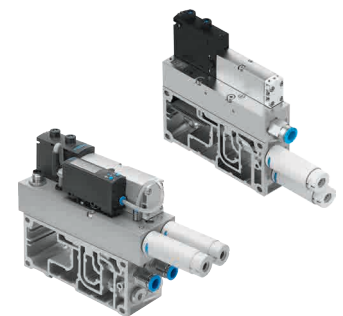

VTSA and CPX: the ideal total solution

The electrical terminal CPX and valve terminal VTSA are really made for each other. Combining them gives you a platform for all applications, in part because of the integration of all common fieldbus systems or Ethernet via terminal CPX. CPX provides sophisticated diagnostic concepts that reduce standstills, increase availability and cut operating costs.

Benefits

- Integration of many safety functions such as the PROFI-safe shut-off module.
- Comprehensive intelligent diagnostic concepts for up to 35% less unplanned downtime:
 - LED for fast troubleshooting
 - Ethernet web monitor for fault finding
 - Condition monitoring for analogue modules
 - Individual channel diagnostics for I/O
- Modules for digital and analogue I/O functions with all common connection types
- Integrated pressure sensors
- Many technology modules, e.g. module CPX-CEC-M1 for 2.5-D movements or versatile electronic cam disc functions

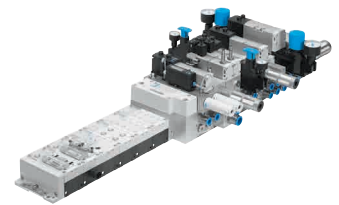

CPX in polymer version

The modular electrical terminal CPX in all-metal version

CPX on the inside, metal on the outside: the fully modular solution for tough areas of applications such as the heavy machine building and automotive industries. With comprehensive function and system integration and all-metal I/O modules and connection blocks, individually expandable.

Benefits

- Dirt-resistant, smooth surface with few edges or recesses
- Longer service life of the sensitive sensors in harsh and dirty environments
- Ideal protection against welding spatter

Also available as CPX-AIDA

Connection technology for PROFINET and power supply based on the push/pull principle in compliance with AIDA (Automation Initiative of German Domestic Automobile Manufacturers).

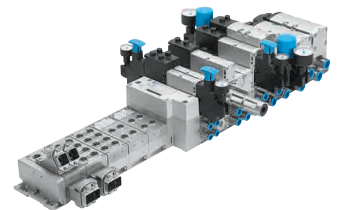

CPX in metal version with push-pull



The modular electrical terminal CPX in control cabinet version

CPX-L with polymer connection blocks and economical I/O modules. Optimal for control cabinet installations due to the new push-in connection technology and three wires for each channel. Can be combined with all polymer-based CPX modules and bus nodes.

Benefits

- Attractively priced digital inputs and outputs with IP20
- Push-in connectors with spring force for quick installation
- Reduced fitting space for compact control cabinets

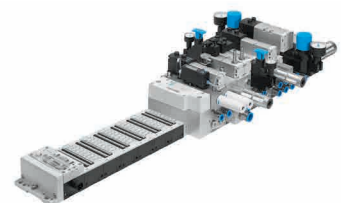
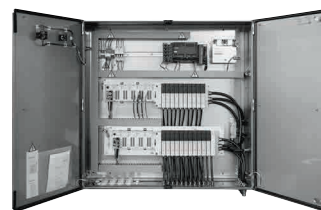

CPX for the control cabinet

Unique services from Festo

Customised and comprehensive

Festo services cover the entire value added chain, from initial configuration of the VTSA through to operation.

Services

- Machine analysis for energy efficiency for a further reduction of the total cost of ownership (TCO)
- Service Energy Monitoring System (GFDM) for
 - Compressed air quality analysis
 - Compressed air consumption analysis
 - Leakage detection and elimination

- Product Key for fast and comprehensive information on the product
- Service2see videos and application notes for simple commissioning can be found on YouTube or the Festo Support Portal
- Schematic Solution for EPLAN projects are available in the Festo App World

Product Key – the fast route to more information

Scan, look and discover with the Product Key as an auto ID function. Access the right information from anywhere at any time. Scan the data matrix code on the product to obtain all the information about the product. For example, you can use the product key to quickly find device description files, function elements, drivers or supporting media like films and application notes for easy commissioning.

Or break down a valve terminal into its individual components and search specifically for spare parts and then order them directly. Try it for yourself!

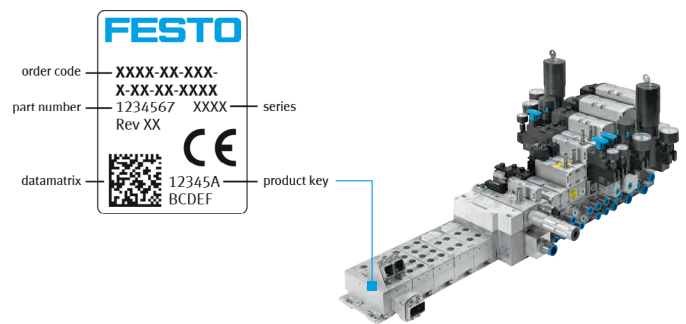

Schematic Solution for EPLAN projects from the Festo App World

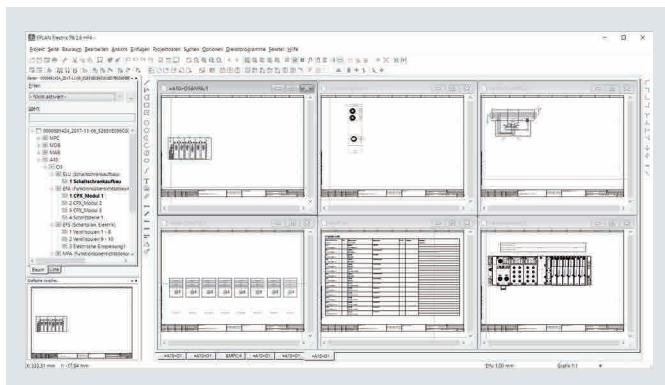

This is what the documentation for your project looks like.

Manually documenting an EPLAN project can take up to 4 hours. Depending on the complexity, this process can also be prone to errors. In general, it involves a well-paid engineer spending time on a less than productive activity. Schematic Solution allows you to use this time to add value instead – and to create project documentation without any errors.

Interested?
Then have a look:
→ www.festo.com/appworld



Manual

- Break down the order code into its individual components
- Find and download macros
- Create the circuit diagram manually

Results

- 2-4 hours per configuration
- High number of errors, depending on complexity
- Low added value

Automated

- Enter the order code
- Order the EPLAN project

Results

- Automated solution in just a few minutes
- Significantly fewer errors

Wide range of electrical connection options

Free choice of electrical installation at each stage

You can completely customise the electrical installation, from an individual valve to a highly complex system solution.

This means that our configurator offers you an individual connection, multi-pin plug, AS-Interface or, with the CPX, one of 12 common fieldbus and Industrial Ethernet protocols.

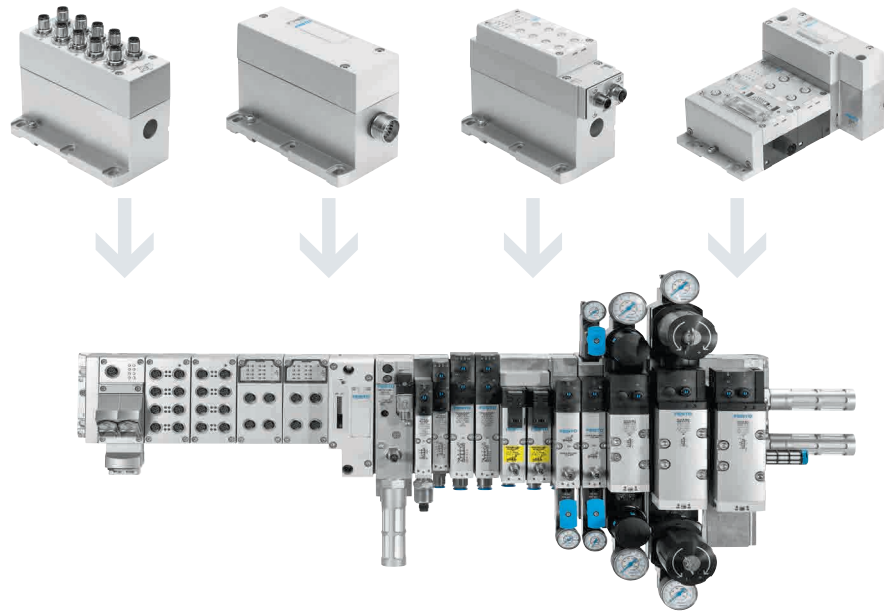

The VTSA system concept

- The option of having all working ports and supply ports in one direction saves space and makes the installation simpler and clearer
- Mounting and operation in one direction
- Clear and functional design
- Large manifold sub-bases for maximum flow rate
- With sturdy metal NPT or G thread or with pre-assembled QS connections or silencers for quick and reliable assembly

Mounting and operating direction

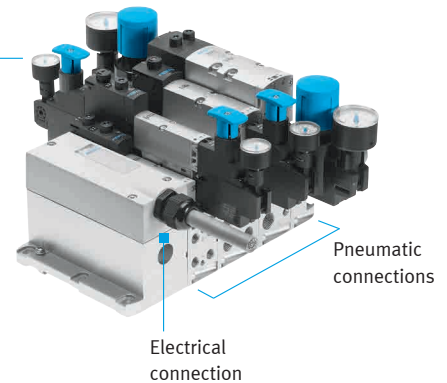

Connection variety at a glance

Electrical installation – advantages of the individual steps

Each individual connection type has different key advantages. To enable you to quickly decide on the appropriate installation solution to suit your requirements, we have provided an overview of them on this page and the next.

Individual valve with M12

Valves on individual sub-bases can be used for actuators that are further away from the valve terminal. The electrical connection is provided by a standardised M12 plug, 24 V DC, to EN 61076-2-101.

Alternatively, you can configure it yourself using a clamped terminal connection or cable ends 24 V DC or 110 V AC.

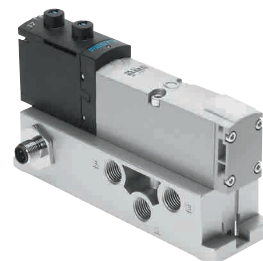

VTSA with individual connection M12

Simple and standardised

Control signals from the controller to the valve terminal are transmitted via standardised individual connecting cables. All the advantages of pneumatic linking can be used to the full.

The valve terminal can be equipped with a maximum of 20 valves and a maximum of 20 solenoid coils. The electrical connection is established via several M12 plugs, 24 V DC. Any compressed air supply and any pressure zones are possible.



VTSA with AS-Interface

A special feature of the AS-Interface is the simultaneous transmission of data and supply power via a two-wire cable. The encoded cable profile prevents connection with incorrect polarity.

Versions

- From 1 to 8 modular valve positions (max. 8 solenoid coils) and with 4 or 8 integrated inputs – that corresponds to 1 to 8 valves.
- With all available valve functions. The connection technology used for the inputs can be selected as with the CPX: M8, M12, Harax quick connection, Sub-D, spring-loaded terminal.

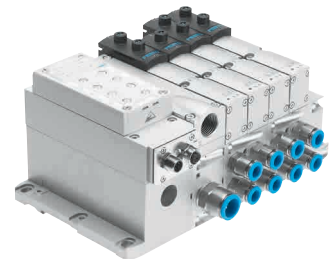

VTSA with multi-pin plug connection

Control signals from the controller to the valve terminal are transmitted via a pre-assembled multi-wire cable or the multi-pin plug connection assembled by the user (spring-loaded terminal), which substantially reduces installation time.

The valve terminal can be equipped with a maximum of 32 valves and a maximum of 32 solenoid coils.

Versions

- Multi-pin plug connection with terminal strip (spring-loaded terminal), 24 V DC or 110 V AC
- Pre-assembled connecting cable, 24 V DC
- Sub-D plug connector for assembly by the user, 37-pin
- Round plug connector M23 (19-pin)



VTSA with fieldbus interface

An integrated bus node manages the communication connection with a higher-order PLC.

This enables a space-saving pneumatic and electrical solution to be implemented. Valve terminals with fieldbus interfaces can be actuated with up to 32 solenoid coils with valve diagnostics.

Optional: additional CODESYS controller for preprocessing or front-end control. Including CAN-open master functionality, diagnostics and Soft-Motion.

Versions

- PROFIBUS DP
- INTERBUS (+ FOC)
- DeviceNet®
- CANopen
- CC-LINK®
- EtherNet/IP
- Modbus®/TCP
- TCP/IP
- EtherCAT®
- Sercos III
- Powerlink
- PROFINET (M12, AIDA push-pull, FOC)

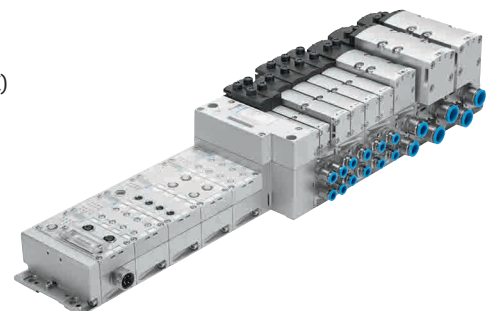

Focus on safety – Safety@Festo with VTSA

Components for implementing safety functions on the VTSA

Soft-start/quick exhaust valve VABF

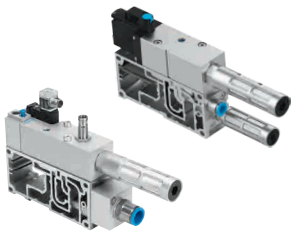

Application

For slow start-up pressurisation, e.g. in order to reduce collisions, for quick exhaust and for building up a specific outlet pressure in a safe and controlled manner.

Safety functions

- Suitable for implementing "safe energy-free switching (SDE)" and "prevention of unexpected start-up (PUS)" with a second directional control valve.
- Category 3¹⁾

- Performance Level d¹⁾
- Diagnostics, switching position sensing
- Control architecture: 2 channels¹⁾

5/2-way safety valve for presses VOFA

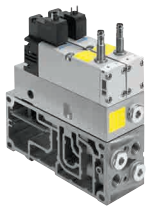

Application

For reversing the motion, e.g. of a press cylinder, in the event of an emergency stop and as protection against unexpected start-up. Specified as a safety device according to the EC Machinery Directive 2006/42/EC.

Safety functions

- Safety function reversing and prevention of unexpected start-up
- Category 4¹⁾
- Performance Level e¹⁾
- Diagnostics, switching position sensing with inductive PNP/NPN proximity sensor

- Control architecture: 2 channels¹⁾
- Safety device to EC MD 2006/42/EC

Pilot air switching valve type VSVA

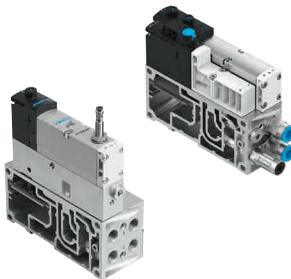

Application

For applications with increased safety requirements such as manual work stations. In these applications, the cylinder pressure must be maintained during the insertion process, but the pilot air for the valve must be exhausted.

New: Manifold sub-base in the size combination 18/26 mm (ISO-02/ISO-01)

Safety functions

- Suitable for implementing "prevention of unexpected start-up" with a second directional control valve with switchable pilot air and a suitable fault exclusion

- Category 3¹⁾
- Performance Level d¹⁾
- Diagnostics, switching position sensing
- Control architecture: 2 channels¹⁾

Pressure zones and selectable pilot air

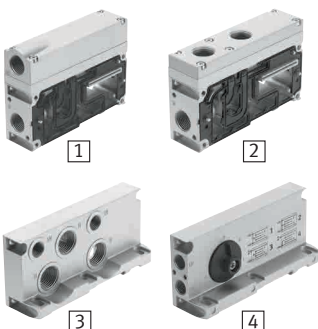

1 Supply plate with common exhaust

2 For dual-pressure operation with separate exhaust

3 Right end plate with threaded connections, and with a choice of internal or external pilot air

4 Right end plate with pilot air selector. Pilot air can be selected by simply turning the pilot air selector. Optionally with ducted pilot exhaust air.

Application: pressure zones

For processes with various media or different pressures. Even if one pressure zone has to be exhausted while for safety rea-

sons another one has to remain pressurised at the same time.

Application: selectable pilot air

Switchable pilot air enables protection against unexpected restart of a system up to Performance Level d. However, this would require additional components.

¹⁾ All specified values are maximum values that can be achieved via suitable integration of the component into the complete system.

Pressure zones

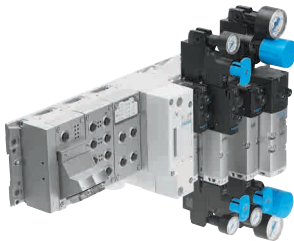

Application

Safe venting of valves or pressure areas: if used together with the valve MS6-SV, certain areas can be exhausted safely whilst the pressure is retained for specific valves or pressure zones. This is a common requirement for protective circuits.

New: Pressure zones can be configured with internal and external pilot air!

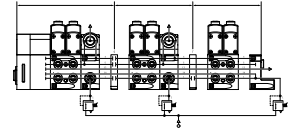

The illustration shows an example of how three pressure zones are built up and connected with duct separation, with internal pilot air.

Valves with mechanical spring return and switching position sensing



Application

For applications with increased diagnostic coverage, for example, for interlinking handling modules on a rotary indexing table. The spring return with switching position sensing can minimise the collision risk here.

Safety functions

- Suitable for implementing "prevention of unexpected start-up (PUS)" with a second directional control valve.
- Category 3¹⁾
- Diagnostics, switching position sensing with inductive PNP/NPN proximity sensor

- Control architecture: 2 channels¹⁾

Valves for pneumatic stopping



Application: mid-position closed

Suitable for temporarily blocking a movement. A lifting cylinder can thus be briefly held in position, depending on the leakage.

Application: mid-position 1 to 2 pressurised, 4 to 5 closed

If necessary, the position can be permanently held by supplementary supply pressure.

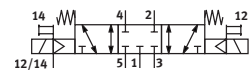

Type: VSVA-B-P53C-ZD-A2-2AT1L



Type: VSVA-B-P53F-ZD-D1-1T1L

Valve for pneumatic manual clamping processes



Application: mid-position exhausted

This means that the cylinder can be manually moved without force. Locking on one side in order to guarantee the clamping process even in the event of a power failure.

Safety functions

- Category 1¹⁾
- Performance Level c¹⁾
- Control architecture: 1 channel

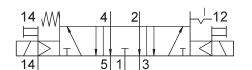

Type: VSVA-B-P53ED-ZD-A1-1T1L

¹⁾ All specified values are maximum values that can be achieved via suitable integration of the component into the complete system.

Electrical safety functions on the VTSA

PROFIsafe shut-off module for CPX



Application

For PROFIsafe-capable controllers for two-channel, self-monitoring, electrical switch-off of the supply voltage to the valves on the valve terminal. In addition, two further safety-relevant consuming devices can be connected to the module.

New: With VTSA-F-CB, the shut-off module is integrated in the pneumatic interface. It enables up to 3 safe voltage zones

Safety functions

- Category 3¹⁾
- Performance Level e¹⁾
- Diagnostic coverage 90-99%
- Control architecture: 2 channels¹⁾
- Safety device to EC MD 2006/42/EC (German Technical Control Board (TÜV) Certificate)

PROFIsafe input module for CPX



Application

For PROFIsafe-enabled controllers for actuating up to 8 safety-related switching devices such as, for example, emergency stop, light barriers or roller levers (OSSD/contact-based sensors)

Safety functions

- Category 4¹⁾
- Performance Level e¹⁾
- Diagnostic coverage 99%
- Safety device to EC MD 2006/42/EC (German Technical Control Board (TÜV) Certificate)

¹⁾ All specified values are maximum values which can be achieved via suitable integration of the component into the entire system.

Even greater safety with VOFA

An addition to the VOFA range

If the switching frequency places a high strain on the valves, the control block VOFA replaces the safety pressure build-up and exhaust valves MS...SV-E. In addition to the 5/2-way safety valve VOFA for presses with protection against unexpected start-up according to EN ISO 14118 and reversing of the cylinder movement, there is now the control block VOFA-L26-T32C-... for safe venting.

The system operates with two 5/2-way single solenoid valves with spring return and has 2 channels.

Performance Level e can be achieved with the corresponding safety electronics for signal processing.

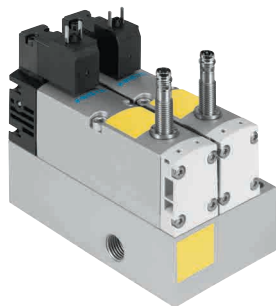
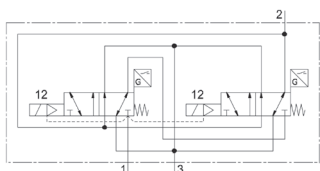

Control block VOFA-L26-T32C-...



VTSA – optimally equipped for digitalisation

Industry 4.0: things communicate with one another



More communication from controller to controller or subsystem to subsystem, horizontal as well as vertical connectivity with a uniform information model, including the cloud: these are the hallmarks of a fourth industrial revolution – Industry 4.0. The traditional, inflexible automation pyramid will cease to exist in the foreseeable future. The modular

electrical terminal CPX as well as the valve terminals are making an important contribution to this transformation.

Dashboards – software and cloud services make the difference

The terminal CPX and the valve terminals connected to it provide comprehensive data for analyses via fieldbus. All the key characteristics and data of the selected products and sub-systems are now in the cloud – without the need for programming. As a result, the data is available anywhere in the world and at any

time, including on mobile devices. Dashboards for CPX/VTSA are in development.

The following platforms will be supported in the future:

- Festo My Dashboards
- Siemens MindSphere
- Rockwell FactoryTalk
- Others available on request

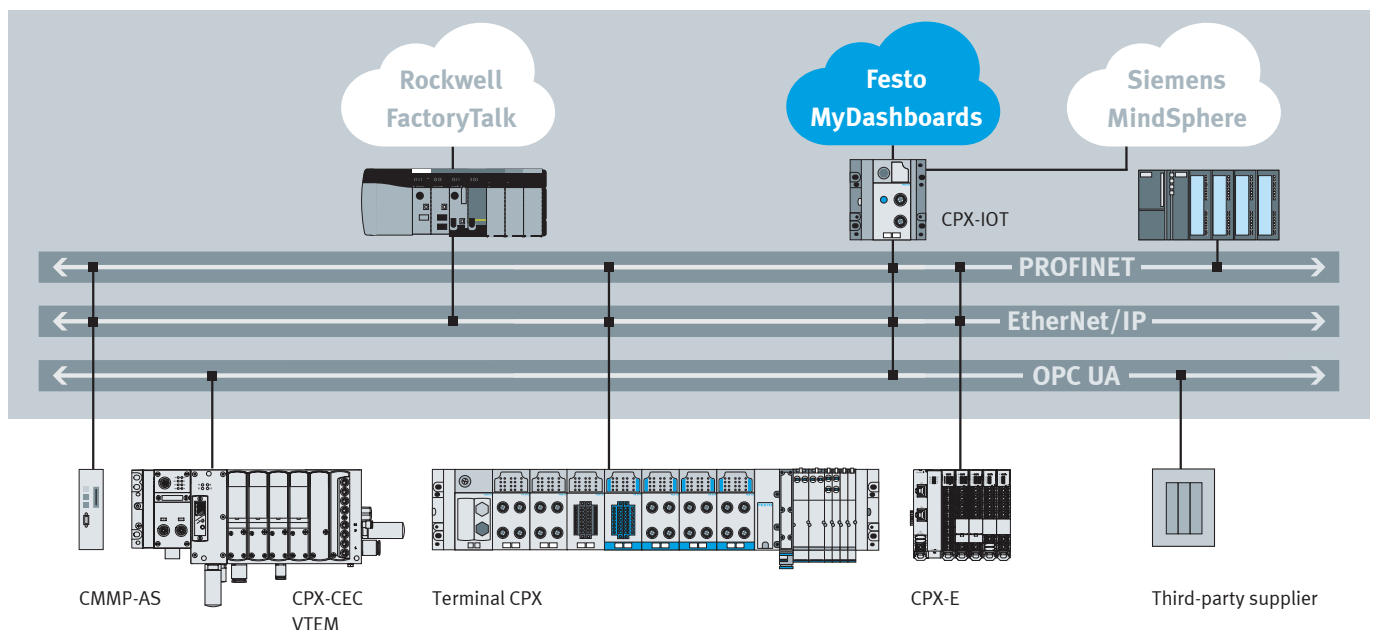
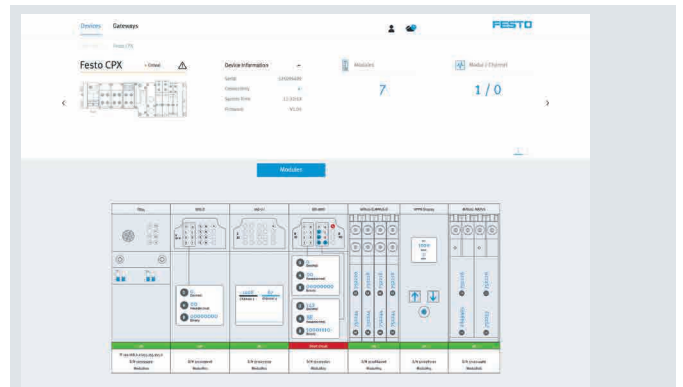

VTSA – expertise and functionality all in one.

Key to the ISO valve terminal VTSA is the expertise of specialists and experts at Festo, the inventor of the valve terminal. It was created to help you be even more productive thanks to ...

- ... its flow rate performance
- ... the complete range of pneumatic functions
- ... the highly communicative characteristics
- ... its sturdy and highly modular and flexible design
- ... the free choice of electrical installation
- ... the many function integration options
- ... the integrated safety features to ISO standard 13849-1 and the EC Machinery Directive.

In short: standardisation + modularity + function integration + Safety@Festo

In this example from an application in fuel cell automation, see how functions that were previously used separately have now been integrated in the valve terminal:

Protection class IP65/67

Ideal for harsh environments: VTSA with electrical terminal CPX in metal version. This fulfils the requirements of protection class IP65/67, and has extra dust protection.

Soft-start/quick exhaust valve

Minimises the risk of damage or accidents after an undefined stop (emergency stop) by a slow and controlled movement of the cylinder to its initial position.

5/2-way valve with pressure regulator, pressure gauge and exhaust air flow control

Six individual components are rolled into just one for the design engineer to install. This saves time during design, and fewer mounting holes are required on the machine.

Fieldbus interface

Bus systems offer time advantages when it comes to wiring, commissioning and troubleshooting.

Sensor input module

Avoids having to order and wire separate sensor/actuator boxes. This reduces the ordering workload and streamlines all the subsequent processes. The diagnostic function makes troubleshooting simpler.

Implementing safety functions

A high Performance Level d/e is often required in applications. With standard components and certified safety devices from a single source like the PROFIsafe shut-off module with control block VOFA, it is easy to comply with these performance levels.

2x 3/2-way valves with pressure shut-off plate

It is not necessary to depressurise the whole system when replacing a valve. The clamping cylinders maintain their position, and the dancer tension is maintained. This saves material costs in the event of stops and restarts.

