



SWIVEL FOLDING MACHINE
MultiPowerBend MPB and MPB UD

MultiPowerBend MPB and MPB UD

The MPB and the MPB UD are our allrounders for thin metal processing. Their characteristics: simple and quick handling, high production output and rich equipment.



The MPB Series brings in the functional perfection of swivel folding machines to thin sheet metal processing. Precision, performance and velocity of these machines lead to a decrease of costs per unit in mass production. At the same time equipment options and the powerful software ensure complete freedom in the production of prototypes, single orders and small series.

MPB UD: Up-and-Down-technique for more efficiency

The option to bend up and down facilitates the handling of large and heavy sheets as they do not need to be turned over manually. The machine is

able to execute more processing steps in shorter times. This is perfect for mass production of large-scale roof- and facade elements.

Shortened set-up times: the rotating clamping beam

Changing jobs or complex tasks with different folding beam tools – equipped with a rotating clamping beam the MPB offers a second set of tools at any time. Moreover, the rotating clamping beam has the advantage of a changeable clamping beam geometry. This offers you additional clearance for bulky workpieces.

Standard equipment

MPB	MPB UD
Graphic control POS 2000 Professional with touchscreen mounted on swivel arm	
Servo-converter controlled drives for folding beam, clamping beam and back gauge	
CNC-positioning gauge/back gauge: 10–1,000 mm with sheet support table and gauge fingers	CNC-positioning gauge/back gauge in U-shape: 10–2,400, 10–3,200 or 10–4,000 mm with up to 5 gauge sectors (810/1,610/2,410/3,220/4,030) incl. pneumatic pop-up gauge fingers, lateral angle gauge and balls in table
Bottom beam blade: gauge min. 10 mm, 700 N/mm ²	Bottom beam blade: 20 mm, radius 1.5 mm, 45° with finger grooves, 1,100 N/mm ²
Folding blade: 10 and 25 mm, 700 N/mm ²	Folding blade: 10, 15 or 25 mm, 1,100 N/mm ²
Clamping beam blade: sharp nose, 30°, radius 1.5 mm, 1,100 N/mm ²	
	Up-and-Down-folding beam: automatically controlled
Folding beam adjustment: manual, 80 mm	Folding beam adjustment: motorized, 160 mm, program controlled
	2-beam light barrier for operation from the rear
Footswitch	Footswitch on rail for lateral movement and second footswitch for operation from the rear
Anchor plates incl. dowels	



With a rotating clamping beam the MPB keeps a second set of tools in readiness.

Optional equipment

MPB	MPB UD
Rotating clamping beam as automatic tool changing system (necessary when using a goat's foot blade)	
Hydraulic tool clamping system	
Crowning system for folding beam	
Folding beam adjustment: motorized, 80 mm, program controlled	
Front gauge system for folding beam with electronic readout	
Additional equipment for 2-man-operation	
Footswitch on rail for lateral movement	

Folding on the fast track

The MPB and the MPB UD are swivel folding machines which have the capacity to produce extreme quickly and efficiently. This reduces processing times and costs per unit.

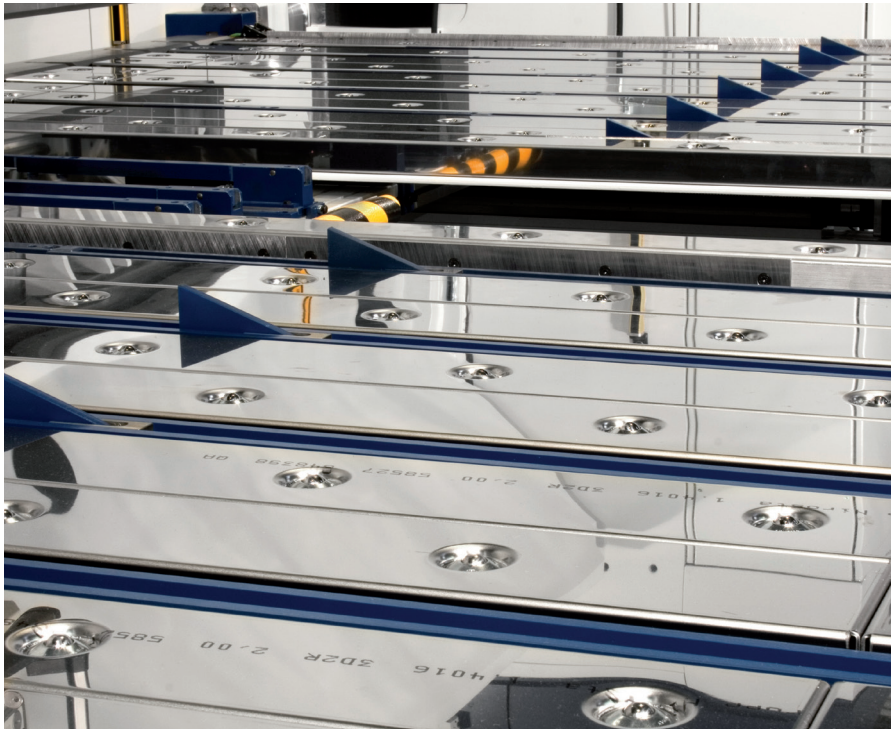

Suited to your standard sheet formats we offer different gauge systems with pneumatic pop-up gauge fingers and ball rollers for an easy and smooth movement of the work piece.



For the fine tuning: crowning system

The eccentric clamping beam drive is known for a quick and exact clamping of sheets. Two dynamic, powerful drive motors swivel the folding beam on both sides – precisely and torsion-free.

In addition, a smooth adjustment of the folding beam minimizes processing times. With the variation MPB UD, in many processing steps, it is even no longer necessary to turn around large sheets manually – this is not only comfortable, but also much more efficient.

Little details, huge effect

The precision of folding starts with an exact positioning of the work piece. With the MPB, this is possible using the lateral angle gauge, pneumatic pop-up gauge fingers and the front gauge system of the folding beam. A rotating clamping beam offers an alternative machine geometry with other clearances. In addition, removable pans make room for down-flange applications.

Gauge options for optimal handling

The workpieces that are produced by the MPB are quite different – so are the sheet formats. We supply you with gauge and table options that are suited to your folding requirements.



Side gauge: The precision of forming starts with an exact positioning of the workpiece. Standard with U- and J-gauge.



The removable pans make room for down-flange applications.

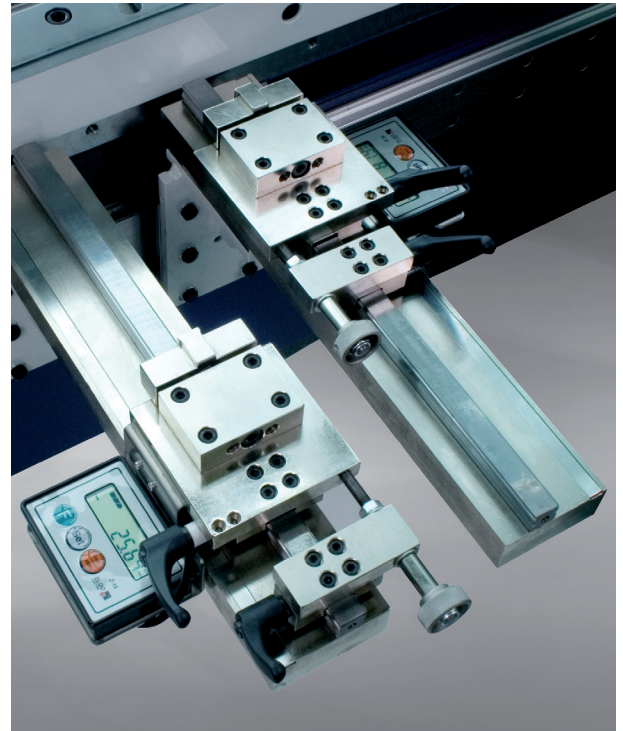

Often the much easier solution: front gauge for folding beam with sheet supports sliding on linear guide.

The feeding of the metal sheet is ergonomically designed for the employee and does not harm the product material. The MPB offers a variety of application opportunities and our customers are working with all kinds of metal sheet formats. This is why we offer a multitude of gauge options. The 1,000 mm gauge forms the basis. Based on this, we offer 1,500 mm-, 2,000 mm- as well as gauges in U- and J-shapes in many different variations.

Back gauges longer than 2,000 mm in width are working with several gauge finger rows (sectors) in order to have the gauge fingers available very quickly in every area and to minimize travel times. The piece is guided on the sheet support table, optionally equipped with brushes or ball casters.

Front gauge folding beam

- Linear guide incl. 2 sheet supports, gauge range up to 300 mm with digital readout

Special accessory back gauge (only with MPB)

- POS 2000 Professional with gauge 10-1,500 mm
- POS 2000 Professional with gauge 10-1,500 mm with 2. gauge sector incl. pneumatic lowering
- POS 2000 Professional with gauge 10-2,000 mm with 2. gauge sector incl. pneumatic lowering
- Sheet support table with brushes or ball casters

Tools

For every task a suitable tool – with high quality segmented tools from Schröder your are able to fold exactly and to bend radii with utmost precision.

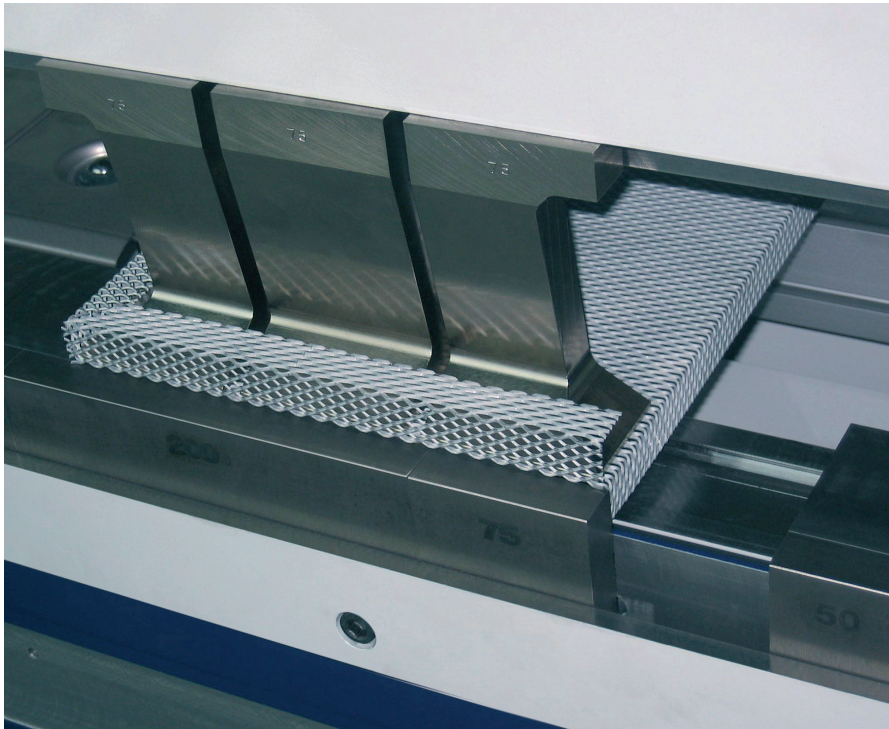

Segmented tools – on request also for individual solutions.



With one single keystroke the hydraulic clamping beam opens up for a quick and precise tool change.

When folding, the right tool is important – with the MPB we have a lot of possibilities. For every bending there is a suitable clamping beam tool, however, if you need a special geometry for your specific requirements – please let us know. We will work out a customer-specific solution for you.

The rotating clamping beam as an option enables the usage of goat's foot tools.



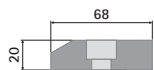
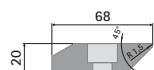
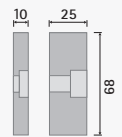
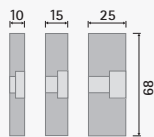
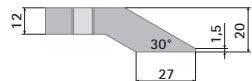

Always tidy: Use our practical tool cart for blades, rails, and segmented tools as optional equipment.

Standard equipment

	MPB	MPB UD
Bottom beam tools	 <p>One-piece rail, gauge min. 10 mm, 700 N/mm²</p>	 <p>One-piece rail, radius 1.5 mm, 45° with finger grooves, 1,100 N/mm²</p>
Folding beam tools	 <p>Folding blades: 10 und 25 mm, 700 N/mm²</p>	 <p>Folding blades: 10, 15 oder 25 mm, 1,100 N/mm²</p>
Clamping beam tools		<p>Sharp nose 30°, for bendings of max. 150°, 1,100 N/mm²</p>

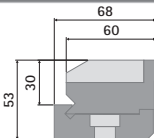
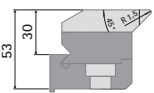
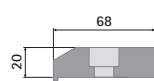
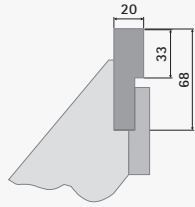
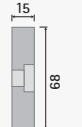
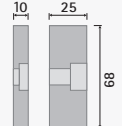
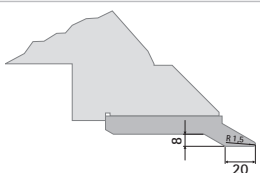
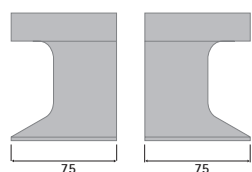
Optional equipment

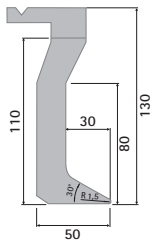
	MPB	MPB UD
Bottom beam tools	 <p>Segmented bottom beam blade: 30 mm high, 1,100 N/mm²</p>	 <p>Segmented bottom beam blade: 30 mm high, radius 1.5 mm, 45°, 1,100 N/mm²</p> <p>(only in combination with special folding beam and folding blade height of 101 mm)</p>
	 <p>Segmented bottom beam blade: surface-hardened or high tensile strength material, 1,100 N/mm²</p>	
Folding beam tools	 <p>Segmented bottom beam blade: 20 mm, incl. clamping rail to take up segmented folding blades, surface-hardened, 1,100 N/mm²</p>	
	 <p>Folding blade: 15 mm, 700 N/mm²</p>	
	 <p>Folding blade: surface-hardened or high tensile strength material, 1,100 N/mm²</p>	
Clamping beam tools	 <p>Tinsmith blade: directly screwed, radius 1.5 mm, 20° oder 30°, 1,100 N/mm²</p>	<p>Examples</p>  <p>Corner parts</p>  <p>Segmentation of goat's foot blade</p>
	 <p>Goat's foot blade: 130 mm, 30°, radius 1.5 mm, divided incl. corner parts, clearance 50 mm (only in combination with rotating clamping beam usable), 1,100 N/mm²</p>	

POS 2000 Professional – intelligent graphic control for efficient processing

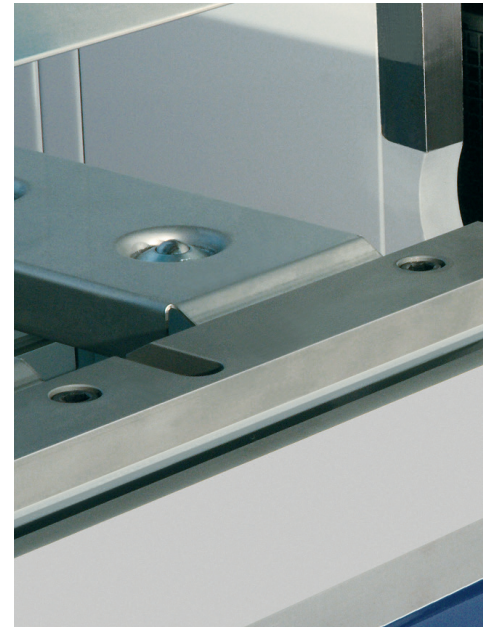
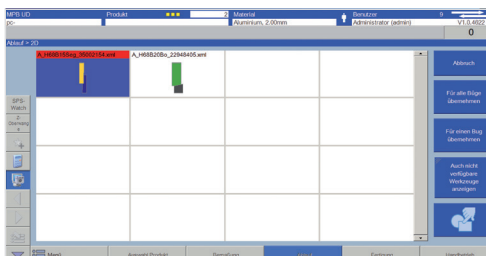
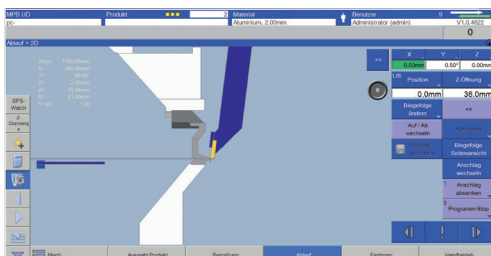
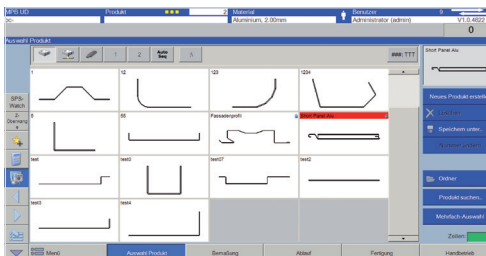
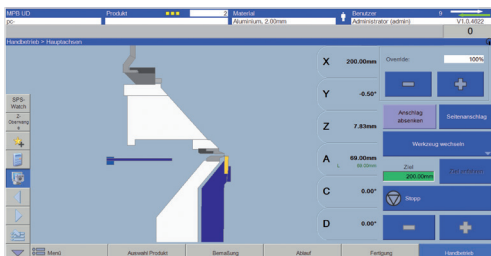
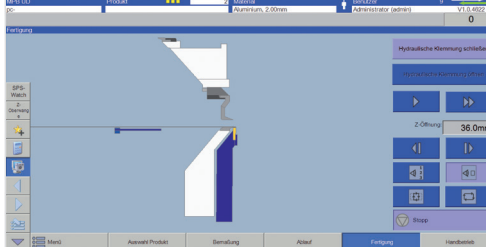
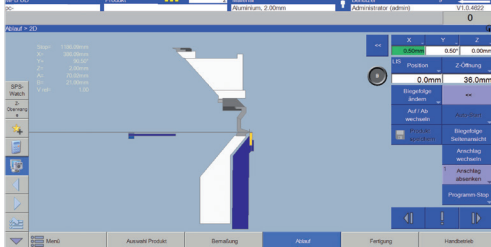
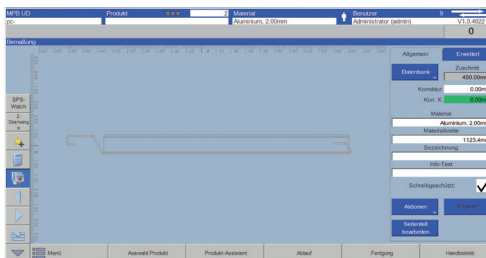
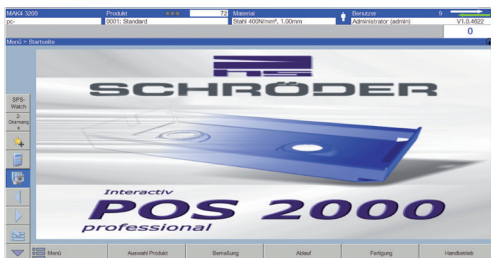

The lowerable folding beam is necessary to bend bigger radii with high precision. As an option, a motorized folding beam adjustment is available, controlled by the graphic control POS 2000 Professional.

Graphic control POS 2000 Professional: The result is always in front of your eyes – from the first steps to simulation.

The swivel folding machines MPB and MPB UD also owe their high speed and efficiency to their control that can be operated easily on a touch display mounted on a swivel arm. The POS 2000 Professional used for this machines is very well known in the industry – proven and well-developed.

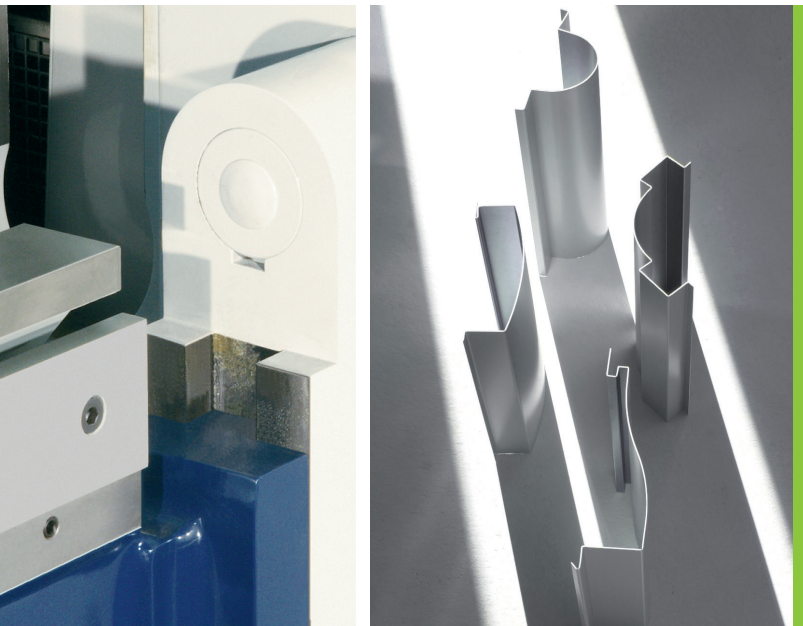

Thanks to the graphical interphase of our software control and the multiplicity of tools it is also possible to produce sophisticated bending shapes without any difficulties.

The POS 2000 Professional is able to visualize every processing step – this can be done through a schematic representation of the swivel folding machine, workpieces and tools. Even before the first metal sheet is placed on the machine, a folding simulation can be conducted in order to test the folding program. What makes our software control so unique and user-friendly for the operator: Every necessary action of the user such as turning over the sheet, is shown per every single folding step.

In short: Whether programming, simulation, tests or mass production is needed, your employees will be ideally supported by the POS 2000 Professional control.



POS 2000 Professional

- Windows 7 operating system
- Extensive profile catalog, unlimited expansion possible
- Automatic cut calculation
- Material and tool library
- True-to-size bending simulation
- Zoom function
- Speed of the CNC-axis may be adjusted without

Options

- Pressing- and Radius-Step-Bending-Function (additional crowning system recommended)
- Pneumatic pop-up finger
- External programming (POS 2000 Professional PC-Version)
- Remote maintenance

Dimensions and technical data

MPB und MPB UD



MultiPowerBend	2,500 x 2.5	3,200 x 2.0	4,000 x 1.75
Working length (a)	2,520 mm	3,220 mm	4,020 mm
Sheet thickness (400 N/mm ²)	2.5 mm	2.0 mm	1.75 mm
Machine length (b)	4,120 mm	4,820 mm	5,620 mm
Length of working area (c)	2,854 mm	3,554 mm	4,354 mm
Machine width (d)	1,590 mm	1,590 mm	1,590 mm
Back gauge, width 1,000 mm (e)	2,450 mm	2,450 mm	2,450 mm
Machine height (f)	1,619 mm	1,619 mm	1,619 mm
Working height (g)	917.5 mm	917.5 mm	917.5 mm
Weight	3,570 kg	4,025 kg	4,730 kg
Clamping beam			
Stroke	160 mm	160 mm	160 mm
Drive power	1.1 kW	1.1 kW	1.1 kW
Speed	100 mm/s	100 mm/s	100 mm/s
Folding beam			
Folding beam adjustment	80 mm	80 mm	80 mm
Drive power	2 x 2.2 kW	2 x 2.2 kW	2 x 2.2 kW
Speed	105°/s	105°/s	105°/s
Back gauge			
Speed	300 mm/s	300 mm/s	300 mm/s
MultiPowerBend UD			
Working length (a)	2,520 mm	3,220 mm	4,020 mm
Sheet thickness (400 N/mm ²)	2.5 mm	2.0 mm	1.75 mm
Machine length (b)	4,120 mm	4,820 mm	5,620 mm
Length of working area (c)	2,854 mm	3,554 mm	4,354 mm
Machine width (d)	1,790 mm	1,790 mm	1,790 mm
Back gauge, width, U-Shape (e)	3,760 mm	4,460 mm	5,310 mm
Machine height (f)	1,619 mm	1,619 mm	1,619 mm
Working height (g)	917.5 mm	917.5 mm	917.5 mm
Weight	3,950 kg	4,640 kg	5,170 kg
Clamping beam			
Stroke	160 mm	160 mm	160 mm
Drive power	1.1 kW	1.1 kW	1.1 kW
Speed	100 mm/s	100 mm/s	100 mm/s
Folding beam			
Folding beam adjustment	160 mm	160 mm	160 mm
Drive power	2 x 2.2 kW	2 x 2.2 kW	2 x 2.2 kW
Speed	105°/s	105°/s	105°/s

Dimensions: MultiPowerBend

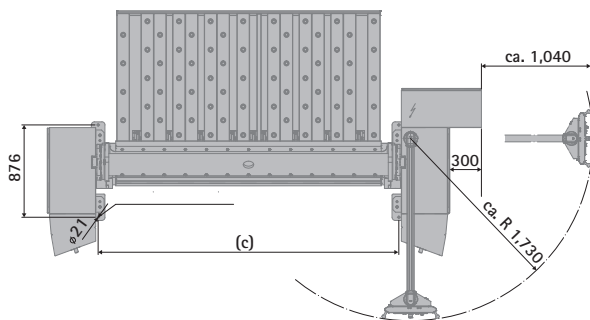
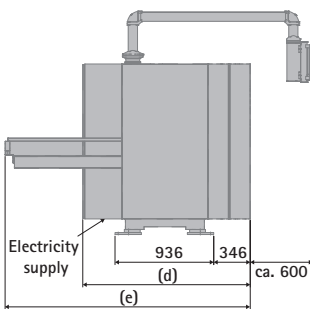
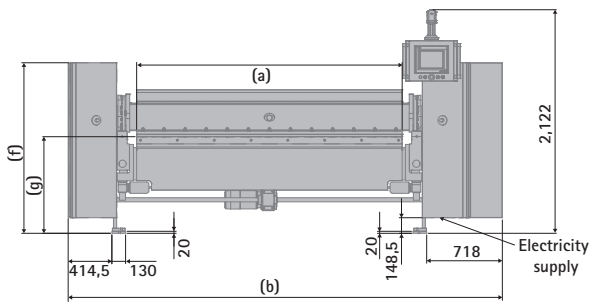

Dimensions: MultiPowerBend UD

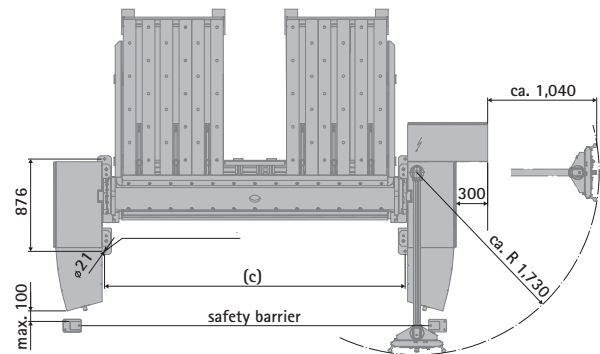
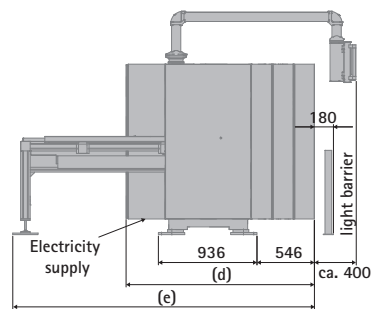
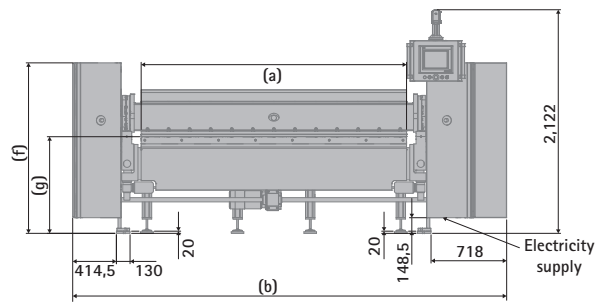

All dimensions in mm

Special accessory extensions

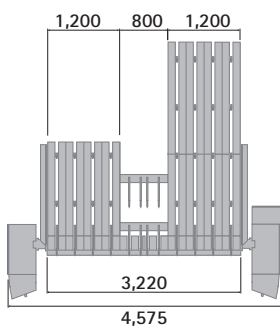

J-Shape 3,200/1,600, 4 x 800 mm
J-Shape 4,000/1,600, 5 x 800 mm

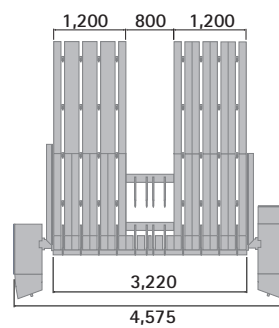

U-Shape 2,400, 3 x 800 mm
U-Shape 3,200, 4 x 800 mm
U-Shape 4,000, 5 x 800 mm

Standard colour: RAL 7035 light grey, RAL 5003 Sapphire blue. Special painting at an extra charge



Schröder Group

The Schröder Group consists of Hans Schröder Maschinenbau GmbH, which is located in Wessobrunn, Germany, and SCHRÖDER-FASTI Technologie GmbH, which is located in Wermelskirchen, Germany.

Founded in 1949, Hans Schröder Maschinenbau GmbH unifies traditional and modern approaches in machine building: Successfully managed as a quality and customer-oriented, family-owned company, Hans Schröder Maschinenbau is specialized in the development of modern machine concepts for bending and cutting sheet metal.

The successful integration of the Fasti Company in 2006 and its worldwide presence make the Schröder Group one of today's leading providers of machines for bending, cutting, beading, flanging, and circular bending all types of sheet metal. The company's precision machines range from proven solutions for craftsmen to innovative, high-performance machines for automatic industrial production processes. Overall, the Schröder Group currently employs more than 240 people at various locations at home and abroad.

All information provided as a guide only
and subject to change at all times.
14-1832-HSM 140206ENv01

Hans Schröder Maschinenbau GmbH
Feuchten 2 | 82405 Wessobrunn-Forst | Germany
T +49 8809 9220-0 | F +49 8809 9220-700
E info@schroedergroup.eu
www.schroedergroup.eu

SCHRÖDER
GROUP