

PERMANENT MAGNETIC SYSTEMS

TECHNOFLEX®
The Power to Perform

PERMANENT MAGNETIC SYSTEMS

THINK GREEN

MAGNETIC COUPLING, M SERIE

Outer hub

Bell house

Inner hub

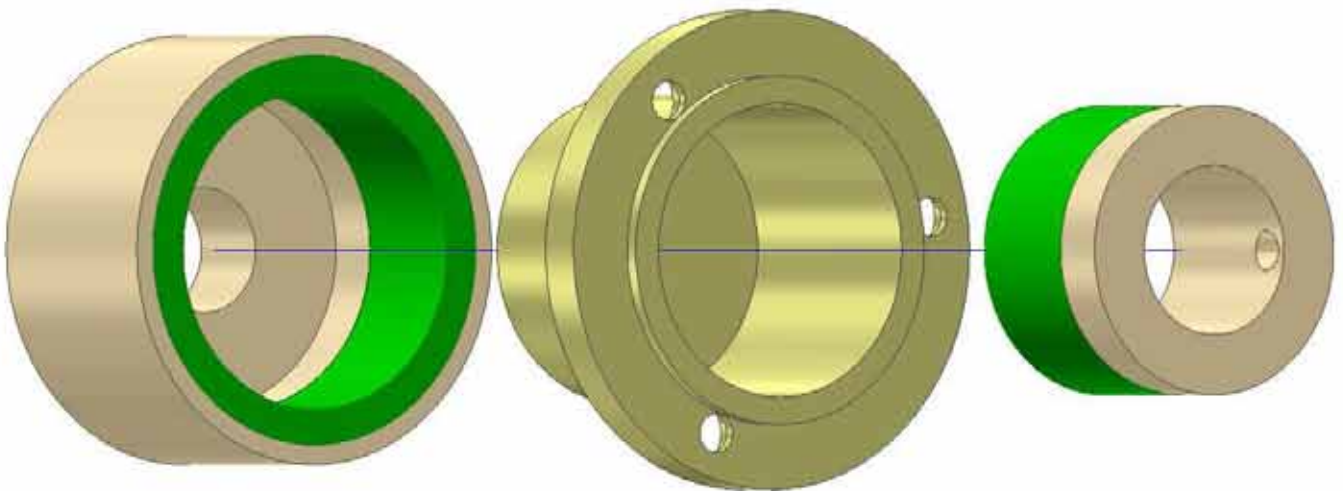

TECHNOFLEX
POWER TO PERFORM



Magnetic Couplings - Design and Function

Technoflex magnetic couplings M-Series is a unique series of permanent magnetic couplings produced and designed after the costumers requirements in the best material. The magnetic coupling is a coupling without mechanical contact which provides a long service life as there is no wear end tear. In other words a maintenance free solution.

The high requirements and testing in our own facilities provides a product of very high quality. The magnetic coupling can be designed for applications where torque limiter is required.

Technoflex magnetic coupling M-Series can be built in different ways. For example an inner hub and an outer rotor where the parts are not touching. A wall/bellhouse can be supplied to separate media or pressure.

Technoflex M-Series magnetic couplings are torque limiters and can be used in pumps, gears, actuators and so on.



Sketch of M-Serie® outer and inner drive in a permanent magnetic coupling system:

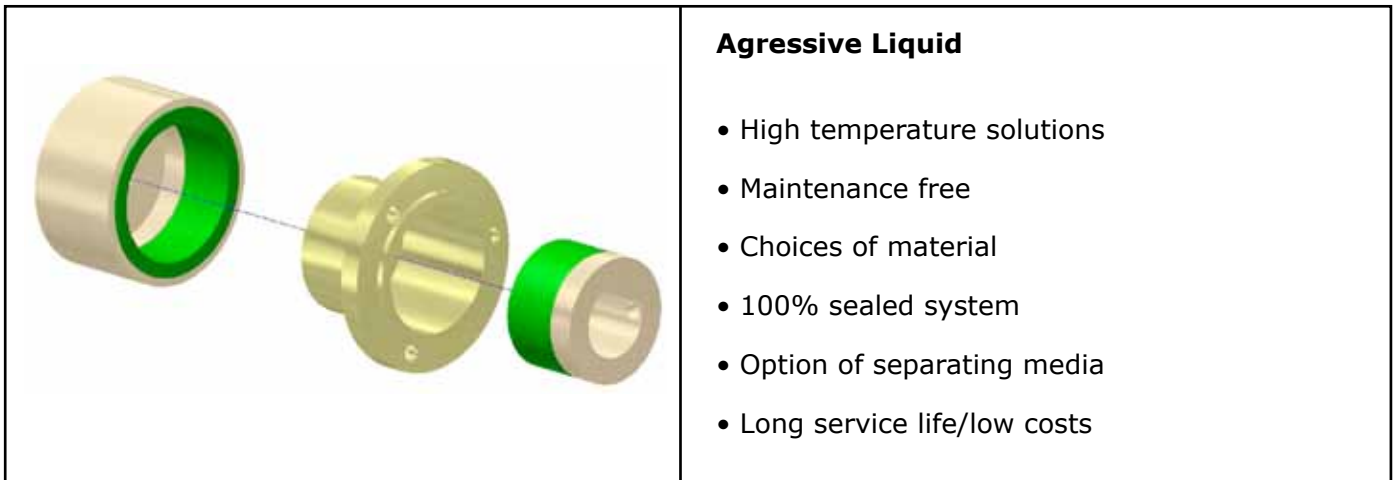

Sketch of M-Serie® outer and inner drive in a permanent magnetic coupling system both radially and axially.

MAGNETIC TORQUE LIMITER AND INSULATING COUPLING

Product qualities

Permanent magnetic coupling.

No-contact torque transfer.

The magnetic coupling can be adapted and designed according to your needs.

Connection shaft to shaft, coupling flange to shaft, coupling flange to coupling flange or as per requirements.

Bore according to ISO (H7), conical or spline. Can be adjusted as per requirements.

Keyway acc. DIN 6885 can be adjusted according to your needs.

Material: steel or stainless, bell house is always stainless or synthetic material

Torque interval from 0,15 Nm to 95 Nm, and interlock system from 100 Nm to 4500 Nm made as per customer specifications.

PRODUCT DESIGN

Below is shown how the design looks on the larger magnet couplings. In co-operation with Technoflex the customer may have the required connection custom made. It is also possible to have a complete coupling dimensioned in close co-operation with Technoflex.

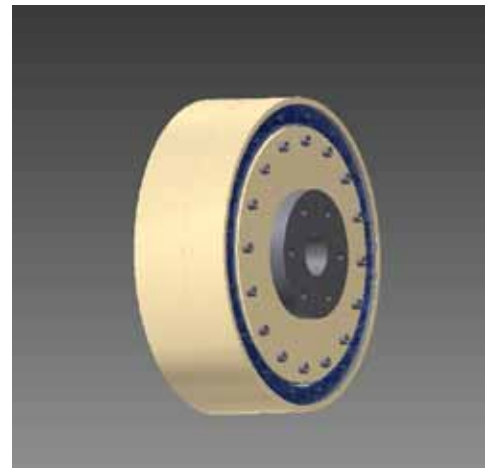
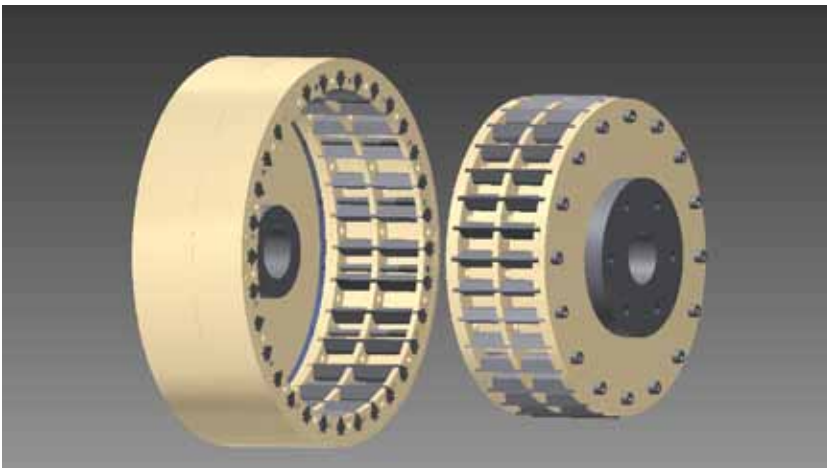

Last but not least Technoflex also develop magnetic couplings as per customer applications in our own test lab – this of course requires that the customer sends the application to Technoflex.

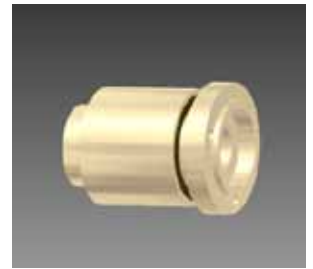

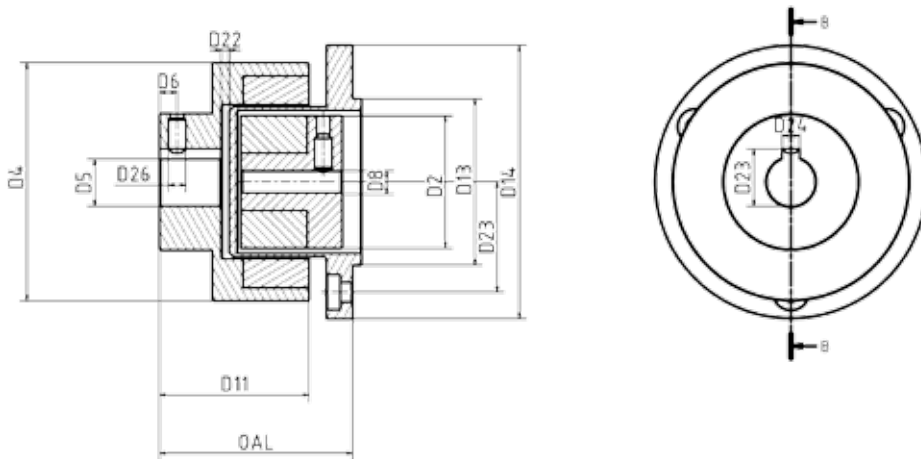

* D2, OAL, and D23 can be adjusted

Size	Tkmax Dyn at 20 °C Nm	t ^m _{ax} 150°C	Max RPM	D5 Min/Max bore In mm Outer rotor	D8 Min/Max bore In mm Inner rotor	OAL In mm	D14 In mm	D2 In mm	D4 In mm	D13 In mm	D11 In mm	D23 In mm
TFM-022	0,220	150°C	4000	4/12	5/10	42	46	20	38	Customized	35	Customized
TFM-2	1,5	150°C	4000	5/15	4/10	46	62	30	52		53	
TFM-3	3	150°C	4000	5/20	5/16	70	79	34	60		55	
TFM-7	7	150°C	4000	9/30	12/22	92	79	58	60		75	
TFM-10	10	150°C	4000	9/40	12/22	79	109	71	86		63	
TFM-14	14	150°C	4000	9/40	12/22	105	96	58	86		98	
TFM-24	24	150°C	4000	12/48	12/30	105	109	71	99		83	
TFM-40	40	150°C	4000	12/50	12/30	119	109	71	99		103	
TFM-60	60	150°C	4000	14/60	14/40	125	143	106	140		112	
TFM-95	95	150°C	4000	14/60	14/40	125	143	106	140		132	

PALL Magnets are made from NdFeB. Hubs are in St52. Bell housing in Stainless 1.4571. This may also be made in another alloy or in synthetic material. Coating in NiCuNi, Nickel coating, with a work temperature of Max 150C. Technoflex can per request produce up to 240C.

Magnetic Couplings - Applications

The magnetic coupling M-Series is being used in the food industry, pharmaceuticals, chemicals and biotechnology industry for:

Applications:

- Industrial pumps
- Gears
- Liquid pumps
- Hydraulic pumps
- Sewage pumps
- Actuators
- Decanters

Sketch of M-Serie® outer and inner drive in a permanent magnetic coupling system:

Technoflex Magnetic Couplings

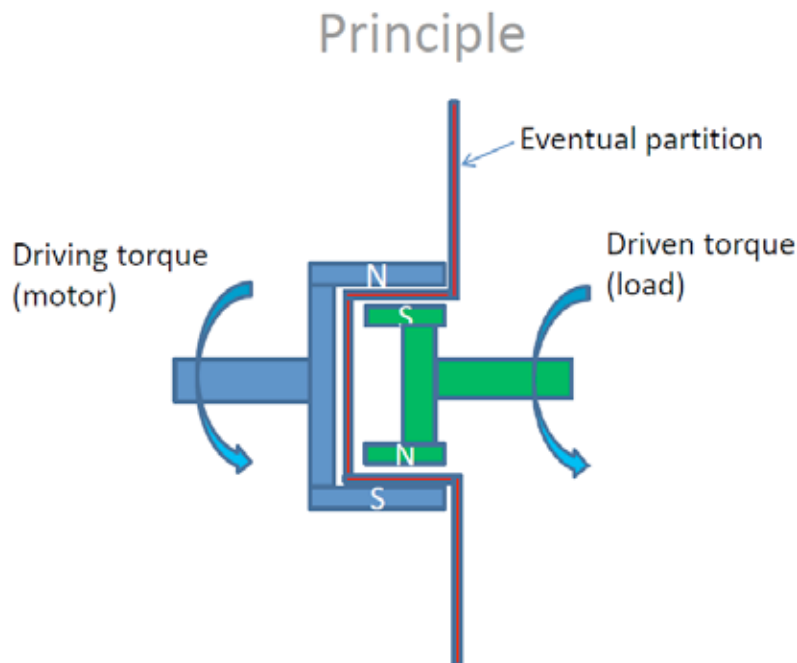

TECHNOFLEX MAGNETIC COUPLING M-SERIE

- The coupling system is sealed for fluids -

Technoflex has after the costumers requirements designed a hermetically sealed magnetic coupling in the best material. The magnetic coupling is an optimized mechanical solution which gives great benefits for our costumers.

Technoflex M-Series magnetic couplings are torque limiters and can be used in pumps, gears, actuators and so on. The coupling is sealed for fluids.

Technoflex magnetic coupling M-Serie has great flexibility in the alignment of the system both radially and axially.

Technoflex M-Series is a low-cost solution for many applications.

