

Rotoclear C2



Expand your perspectives!

Discover the leading camera system for machine interiors.



Insights in sight.



At Rotoclear, we've made it our business to overcome the limits of the senses. Our products create clear insights into your machining processes where you would otherwise be unable to see through liquids or particles.

→ Clear insights for continuous improvement

Whether it's self-cleaning spinning windows or high-tech cameras: Rotoclear's optical solutions accelerate start-up, help prevent collisions and enable you to continuously optimize processes.

This is because the newly acquired visual information provides the basis for valuable insights for making your processes safer, more reliable and more efficient.

In this brochure, you will learn how the Rotoclear C2, the leading camera system for machine interiors, helps to optimize your processes.

You will also get important information on how to configure and install the product – as well as information on the appropriate accessories.

What is the Rotoclear C2?	4
Benefits	6
Hardware features	8
Software features	10
Future options	12
Awards	14
Configuration	16
Technical data	22
Accessories	26

What is the
Rotoclear C2?



The Rotoclear C2 is the world's leading camera system for machine interiors. It was specially developed for the extremely harsh conditions inside cutting machines and is impressively robust and durable.

→ A spinning disc keeps your view constantly clear

How does the system always ensure a clear view of the manufacturing processes despite cooling liquids and flying chips? It's simple: a rapidly rotating disc made of shatterproof, liquid-repellent glass is mounted in front of the lens. Centrifugal force flings droplets and solids outwards and keeps the window permanently clean.

→ 4K views from revolutionary perspectives

Whether you want a clear view from the perspective of the tool or an overview of the machine interior, our self-cleaning Rotoclear C2 cameras create 4K views from revolutionary perspectives – even under the harshest conditions. The intelligent control unit is not only intuitive to use, it also provides zoom functions and lets you evaluate saved videos and photos.

→ The underlying hardware and software

The control unit has HDMI, USB and Ethernet connections and uses TCP/IP and RTSP protocols to give you all the interfaces you need to conveniently stream, save and share image data. The clever software also supports intuitive camera control.

→ What the Rotoclear C2 offers you

Our camera system provides users with crucial clarification of their machining processes. This simplifies the continuous real-time control of your production lines. The Rotoclear C2 also helps you to identify the causes of problems in your production processes and even proactively prevent potential errors. Furthermore, the Rotoclear C2 forms the essential basis for automated image analysis and therefore advanced production automation.

What the Rotoclear C2 can do for you

The Rotoclear C2 provides clear insights into all machining processes. But exactly how does this help your production department, we have summarised the key benefits below.

→ Making production processes in closed systems visible

The Rotoclear C2 grants insight into areas that are otherwise hidden, for instance, cooling liquids or other elements in closed systems that block the view. The system reveals processes that are usually concealed to improve transparency, control and safety in production. Moreover, it allows you to share these hidden processes with other departments, such as marketing or sales, or to use the data for training purposes.

Applications

- Monitoring of machining processes developed in-house (prototyping)
- Training
- Demonstrations by processing experts
- Trade fairs / showrooms

→ Observing machining processes from revolutionary new perspectives

The Rotoclear C2 lets you view processes from the revolutionary perspective – from above (Top view), from the side (Side view) or even from the viewpoint of the tool itself (Tool view). These revolutionary new perspectives, offer insights into your machine processes where you can learn more exciting information from!

Applications

- Observation of machining processes in deep cavities
- Up close viewing and monitoring in large machines

→ Monitoring manufacturing processes continuously in real time

Continuous visual information in real time is essential for optimum process monitoring. Only when you can view the entire process in real time can you also identify where something is going wrong or could be optimized.

Workpiece clamping is the perfect example of this principle: As soon as you discover a clamping error, you can stop the process immediately, vastly reducing scrap costs.

Applications

- Workpiece clamping check in series production
- Detection of undesirable chip clusters

→ Identifying and understanding causes of errors

Occasionally, we come across a process that regularly experiences errors, but the cause of these errors remains a mystery. Continuous visual monitoring and process recording helps you to find, understand and subsequently eliminate the causes of these errors.

Applications

- Determination of the causes of defective workpieces
- Discovery of the causes of crashes
- Identification of causes for handling errors when using automation components

→ Simplifying process monitoring

Production processes need to be monitored constantly. Thanks to the remote feature of the Rotoclear C2, process monitoring can be carried out from wherever you are anywhere in the world. And that's not all: the camera system allows you to monitor multiple machines at the same time. For example, you can simultaneously monitor several machines and the corresponding processes in your production control station.

Applications

- Multi-machine operation (including for older machines)
- Avoidance of elaborate inspection rounds
- Improved flexibility for simplified shift planning

→ Developing your own custom monitoring solutions

Whether you want to monitor tool breakage or detect chip clusters, the requirements for (automated) process monitoring are as diverse as the manufacturing processes themselves. For this reason, we have integrated an API into our camera system for you. This enables you to develop your own custom monitoring functions at any time to take the reliability, efficiency and precision of your machining processes to the next level.

Applications

- Tool inspection
- Workpiece position check
- Monitoring of environmental conditions
- Integration into monitoring systems
- Automated evaluation of images from the manufacturing process

The hardware features of the Rotoclear C2



Always a clear view

The high-speed spinning window in front of the camera lens always ensures a clear view of all machining processes, even in the presence of coolant and flying chips. For the perfect lighting conditions, we have installed specially designed Waldmann premium lighting in our camera heads.



High-resolution images

The camera head provides a live stream resolution of up to 4K with 60 frames per second. But, the images can also be scaled down to lower resolutions and refresh rates such as HD and FullHD. In both cases, you still have crystal-clear images, even in zoom mode. Recording is possible in FullHD and HD.



Tool, top or side view

The Rotoclear C2 camera heads can be mounted at the top (top view), on the side (side view) of the working space or directly on the headstock (tool view), allowing for clear views from revolutionary perspectives.



Alignment sensor for mobile installation

Currently, only the Rotoclear C2 offers you images directly from the perspective of the cutting tool. To enable this revolutionary perspective, we installed an alignment sensor which detects the movement of the camera head and can compensate for it.



Selection of connection options

Whether HDMI, USB or Ethernet cable, our control units offer all the conventional connection options for fast and reliable transmission of image data – and integration of the system into the in-house network.



Flexible installation options

Whether you want to install the camera heads on the side of the wall, within the wall or at the top wall: with numerous options for quick and easy installation, we offer a range of mounting options for an individually optimized camera setup.



Extremely compact camera head

The camera housing of the RotoClear C2 impresses with its small dimensions. It not only allows the camera head to be installed at many different locations inside the machine, but also its compact design results in significantly fewer chip nests forming.



Extended range for large-capacity machines

Our C-Extender signal amplifier easily extends the range of the RotoClear C2 from 20 m to 40 m for use in large-capacity machines. The range can even be extended to 60 m by combining two C-Extenders.

The software features of the Rotoclear C2



Intuitive control

The Rotoclear C2 impresses with its simple user interface. The control is completely intuitive and also works via gestures on touchscreens. For example, you can easily enlarge and move part of an image directly on the screen by swipe zoom, and thus observe machining details at any time.

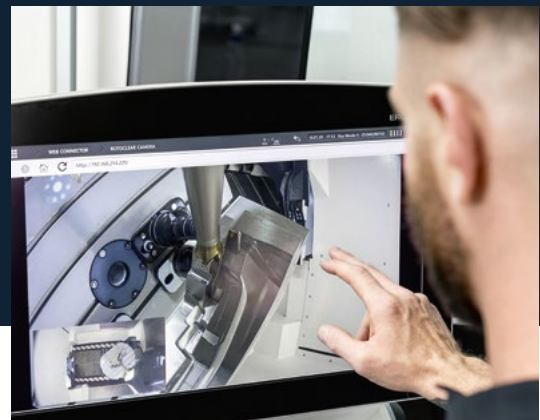

Double perspective

Would you like to observe the process from two perspectives at the same time? No problem. For example, if two camera heads are connected to the control unit, machining can be observed simultaneously from above and from the perspective of the tool, for example.



Streaming & recording

The digital image data can be streamed live via HDMI, TCP/IP or RTSP and can also be recorded in HD and FullHD at any time, making it ideal for process optimization as well as for sales and marketing purposes.

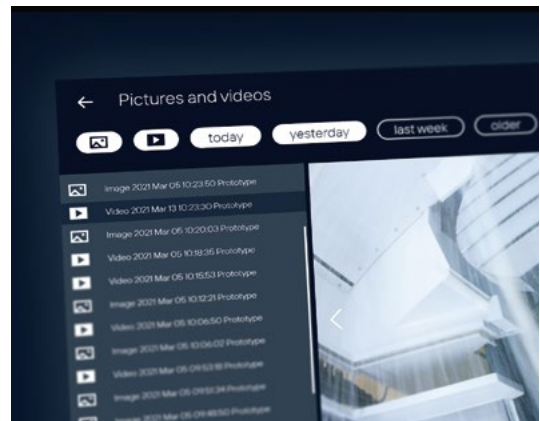

Media gallery

You can easily manage saved recordings using the media gallery. The gallery gives you the option of filtering images and video files by date, provides a preview and delete function, and meta data information.



Remote insights

Wherever you are in the world, whatever client you are using: the simple transmission allows you to view your image data remotely and flexibly at any time. The Rotoclear C2 not only enables remote analysis but also makes process monitoring more flexible.

```

inst
  rotoclear_ip = "192.168.214.22"
  rotoclear_api_port = "7000"
  my_api_token = "01092019"

roc runProcess() {.async.} =
  # create connection
  let conn = await newWebSocket
  
```

API

Would you like to implement new camera functions tailored specifically for your machine? No problem. Our API interfaces provide all the options you need to do this. For example, you can control the camera system directly from your software application or automatically integrate image information into your program workflows.

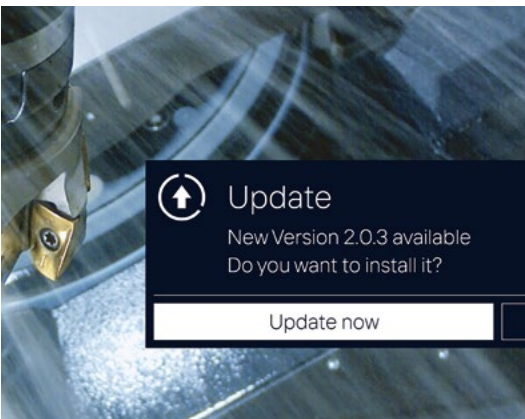

Software updates

In the spirit of continuous improvement, the software of the Rotoclear C2 is always under continuous development. We provide the updates to our customers as downloads or online updates. So you always stay up to date!

Outlook on the options

With its hardware and software features, the Rotoclear C2 already offers many options for observing and optimizing machining processes.

In addition, the camera system is also the essential basis for implementing further valuable functions in the context of automation and process optimization in the future. This is because the Rotoclear C2 platform can supply other intelligent systems with visual information via the API. Here are some examples of what the Rotoclear C2 could make possible in the future.



Automated, event-based recording

With additional sensors, unusual events in the machine tool could be detected automatically and a recording of these events could be triggered fully automatically. A feature like this would of course be particularly beneficial when it comes to analyzing the causes of crashes.



Simulation comparison

Machining processes are often simulated to prevent crashes. But this simulation only helps if it really reflects the machining process in reality. In combination with automated image evaluation, the Rotoclear C2 could enable fully automatic simulation comparison and thus significantly help to optimize machining processes even further.



Chip nest detection

Chip nests can easily impair machining processes. In combination with an intelligent system, the Rotoclear C2 could automatically detect chip nests, thereby informing users immediately through information on the screen or even directly initiating cleaning cycles.



Tool check

Every tool has a limited service life. Together with AI, the Rotoclear C2 could detect the condition of the tool thus indicating when a tool replacement is due.

And what are your ideas?

The use cases mentioned here are just a few examples of what the Rotoclear C2 could make possible in the future. Think about it: What functions could the camera system perform in the context of your machine in the future?

We are looking forward to your ideas. Write to us or give us a call. We are always happy to hear from you.

info@damaskus.se

Two-time award winner!



reddot winner 2020
product design



reddot winner 2020
innovative product



In 2020, our camera system won two Red Dot design awards in one fell swoop: The Rotoclear C2 not only convinced the jury in terms of “Product Design”, but also won the prize in the “Innovative Product” category.



Configuration of the optimal perspective



Tool View

Would you like to observe the machining process up close? The Rotoclear C2 is the only camera system in the world that allows the installation of a camera head directly on the tool headstock.

→ The benefits

This perspective allows the user to always keep a close eye on the tool – and thus gain uniquely detailed insights into the machining process.

→ Our tip

The integration of this camera perspective should be considered when configuring the machine. If you are interested, contact your machine manufacturer about the Tool View option.

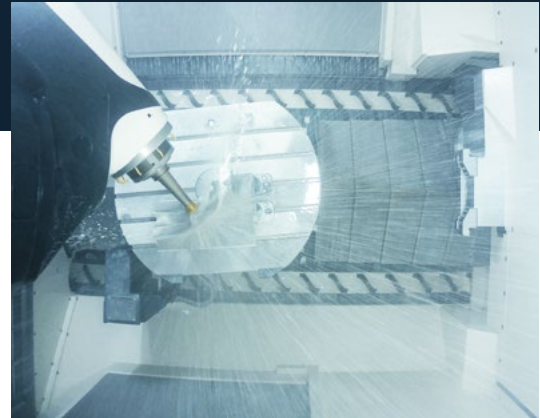

Top View

The perspective from the machine ceiling downwards with the entire machine room in view is the perfect complement to the Tool View perspective.

→ The benefits

Top View enables the user to stay oriented, as reference points and automation components remain in view in addition to the overall process.

→ Our tip

If you consistently align the camera on an X, Y or Z axis, orientation becomes even easier for users.

Whether from the machine ceiling downwards, from the side or very close up from the perspective of the tool itself: The Rotoclear C2 enables a whole range of revolutionary perspectives. You decide which one benefits your machining process the most.



Side View

The Side View of the machining processes can be useful in various cases: On the one hand, users can always keep an eye on the tool change. On the other hand, the side view is also a good alternative if Tool View installation is not possible.

→ The benefits

The view from the side enables detailed imaging without losing sight of the immediate surroundings (such as the tool changer).

→ Our tip

If you retrofit the Rotoclear C2 in your machine, the Side View perspective is also the perfect alternative to be as close as possible to the machining process from the outside.

→ Single vs. dual package

You decide to what extent you need two of these perspectives at the same time: When configuring your C2 setup, you can in fact choose between one or two camera heads (see also page 23).

Selection of focus and data cables



The right focus

To protect the camera as best as possible from the harsh conditions inside the machine, we have encapsulated the camera head. This requires a preset focus. When configuring your setup, you can choose between camera heads with different focus ranges, depending on application.

→ Focus at close range

The F1 lens has a focus range of 200 to 500 mm and is therefore used wherever the camera is close to the action, e.g. in the case of the Tool View perspective.

→ Focus at far range

The focus range of the F2 lens is 500 to 4,000 mm. It is used when the camera needs to have a larger area in view, e.g. in the case of the Top View perspective.

→ Two lenses for close and far range

You can also equip your camera head with two different lenses (and thus two focus ranges). This allows you to remain flexible with regards to the location and perspective of your camera head.

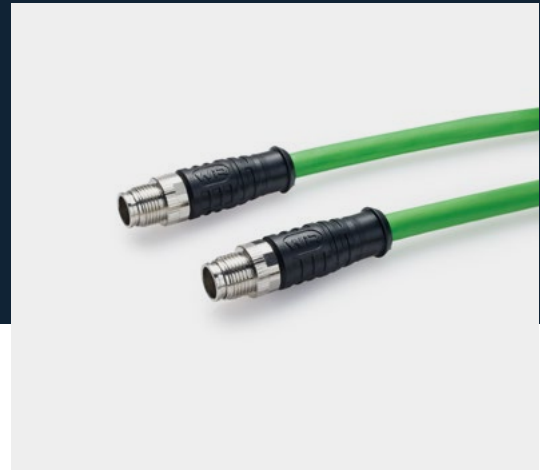

The right data cable

Our data cables ensure data transmission that is as fast as it is reliable. They are resistant to cooling lubricants, suitable for drag chains and specially designed for the harsh conditions in the machine tool.

The data cables are available in the following lengths:

→ 10 m (standard)

→ 20 m

Large-capacity machines may require a range of more than 20 m. With this in mind, we developed our C-Extender signal amplifier to deal with these cases. It connects to the data cable and increases the range from 20 m to 40 m or even 60 m.

- 40 m = 20 m data cable + 20 m with one C-Extender
- 60 m = 20 m data cable + 2 x 20 m with two C-Extenders

As a modular system, the Rotoclear C2 allows you to determine the ideal perspective and select the perfect focus and right length of data cable.

→ Individual focus or desired focus range?

You have your own requirements regarding the focus range of the camera head?
No problem. Whether telephoto or fish eye, we are able to find a lens fitting your requirements. Just get in touch with us for more information.

Integration of the control unit

The Rotoclear C2 control unit has a power supply connection, two interfaces for the camera head, an HDMI port, four USB ports and two Ethernet interfaces.

→ Mounting the control unit

The control unit is typically installed in a control cabinet, For top-hat rail mounting, you can use the pre-mounted top-hat rail clip.

→ Integration in individual control systems

In many cases, the user interface of the Rotoclear C2 can also be integrated directly into your own machine control system – as is currently already the case at DMG MORI, for example.

The system can also be connected to other systems or software applications via the integrated API.





Connection to Ethernet networks

The system can be connected to two networks or connected directly to the computer via a direct Ethernet connection.

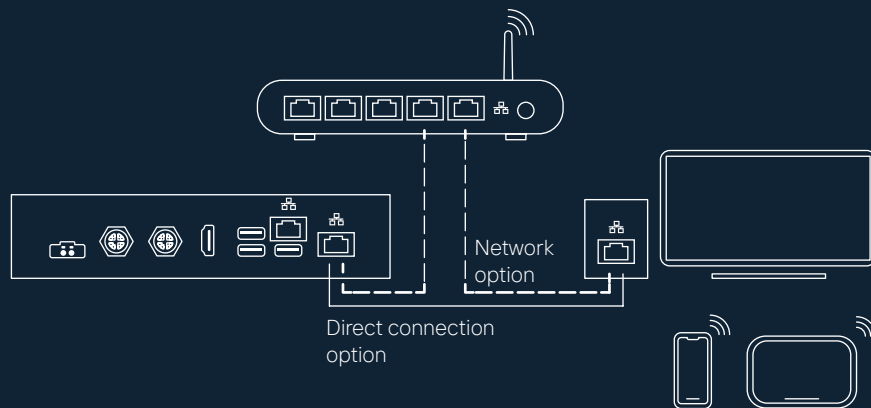

Connection with HDMI

In addition, the system also works independently. In this case, a monitor or touch display is connected directly to the control unit via an HDMI cable.

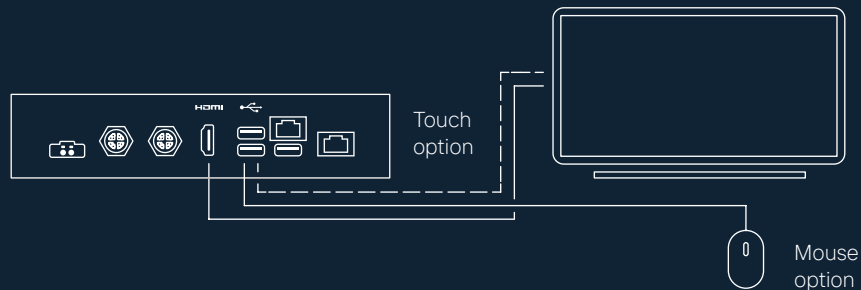

More Details about installation and integration?

Details on installation and setup, as well as other valuable information and tips, can be found in the RotoClear C2 operating manual.

Download now.

rotoclear.com/en/C2-downloads



All technical data at a glance

Whether installation dimensions, connection media or scope of delivery: This is where you will find all technical data for the Rotoclear C2. In addition, if you have any questions about dimensions and details, please feel free to contact us at any time.

→ Connection media

The Rotoclear C2 requires power and sealing air for operation.

Power	24 VDC
Sealing air	1,150 – 1,400 mbar (absolute)

→ CAD data?

Do you need CAD data to include the Rotoclear C2 in your design? Contact us. We will be happy to send you access to the relevant data on request.

→ Installation dimensions

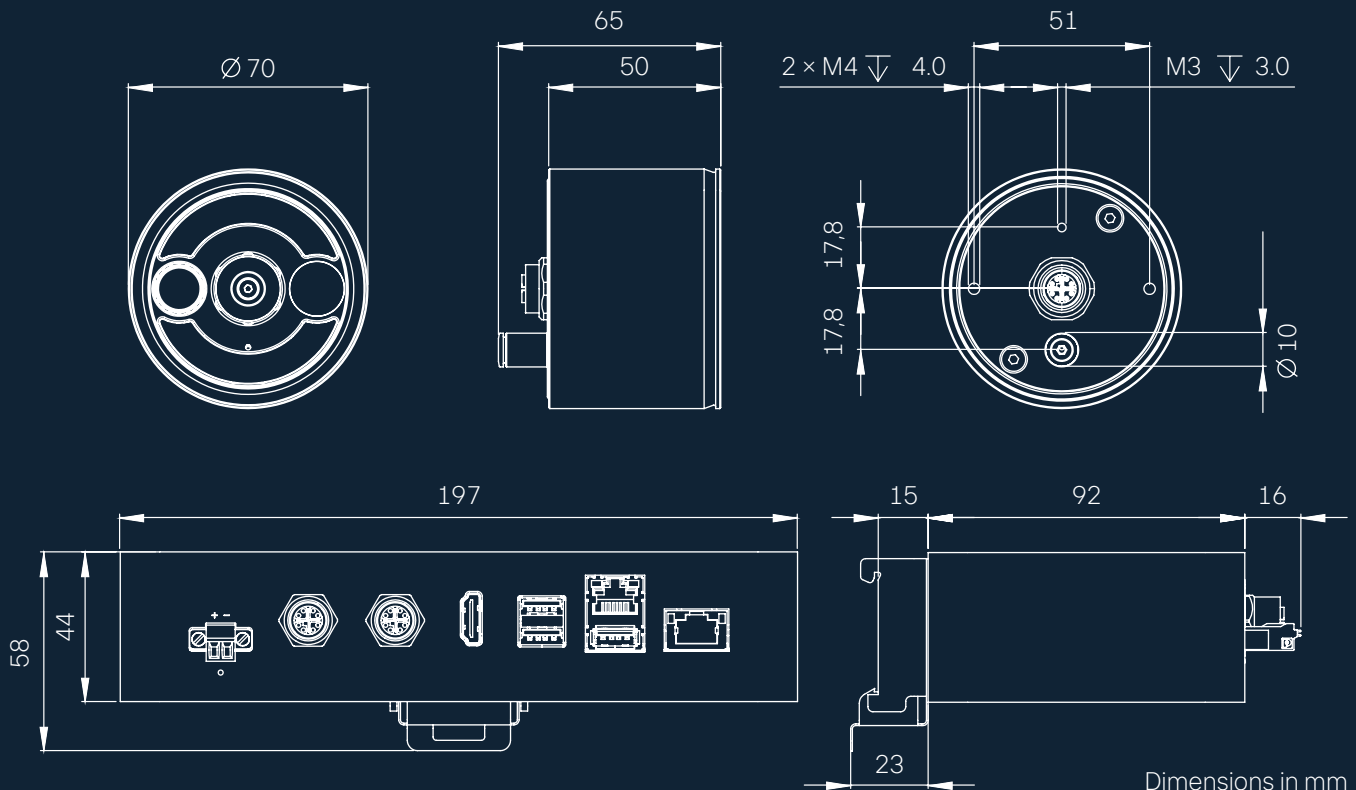

→ Scope of delivery

Depending on whether you want one or two perspectives on your machining processes, we offer two packages: The single package includes one camera head with accessories. The dual package includes two camera heads with accessories.

	Single	Dual
Camera head	1 ×	2 ×
Sealing air line	1 ×	2 ×
Plug connector for sealing air	1 ×	2 ×
Data cable	1 ×	2 ×
Sealing ring	1 ×	2 ×
Covering cap	1 ×	2 ×
Control unit	1 ×	1 ×
Top-hat rail clip	1 ×	1 ×
PCB plug connector	1 ×	1 ×
Suction cup	1 ×	1 ×
Power cable	1 ×	1 ×



Illustration 1:1





ROTO CLEAR

Always a clear view due to fast rotating window.

Compact housing withstands the harshest conditions.

Specially designed Waldmann premium lighting for optimal image quality.

Smart installation options.

The ball mount

The ball mount is the sleekest installation option for your camera heads: The camera is installed inside the sheet metal wall and is thus discreetly integrated into the interior of the machine.

→ Benefits of the ball mount

The camera head can be swiveled $\pm 20^\circ$ and rotated 360° in the ball mount. Because it is in the ball mount, it only protrudes minimally into the working space, hardly allowing for any chip nests to occur.



→ Two easy options installing the ball bracket mount

There are two ways of installing the ball-head bracket. A mounting cutout 115 mm in diameter must be created for version A. The housing of the ball-head bracket can then be mounted in the mounting cutout using a back plate. A mounting cutout of 98 mm diameter with 6xM5 additional threaded holes must be created for version B.

The housing of the ball-head bracket can then be screwed directly into the sheet metal wall without using the back plate. All installation tasks can be carried out from inside the machine's working space.

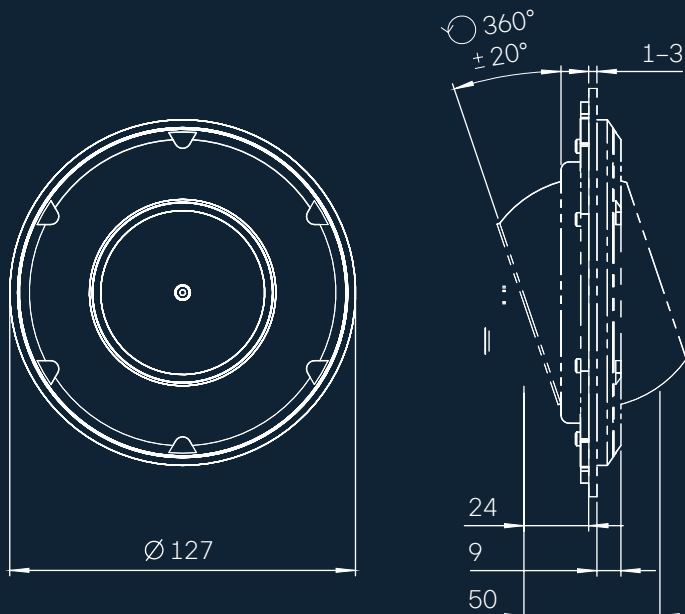

The flex arm mount

In the case of the flex arm mount, the camera head is installed on a ball joint arm at the front so that it extends further into the space. The flex arm can be attached into the sheet metal wall, mounted in front of the wall or simply and flexibly held in place by a magnet.



Benefits of the flex arm mount

The flex arm can be swiveled $\pm 20^\circ$ at each of its joints and rotated 360°, making it easy to set optimal perspectives of the camera head. In addition, the arm ensures that the distance to the process being observed is reduced.

Our tip:

Additional joints in the flex arm bracket let you position the camera even more freely in three dimensions and bring it closer to the machining process.

An optional protective hose ensures that all supply lines in the work area are even better protected.





Through-wall mounting

For sheet metal installation, first a hole is drilled in the sheet metal wall and then the flex arm mount is screwed directly to the wall. This allows you to route the data cable and the sealing air hose through the sheet metal wall to the outside: This means that both run completely outside the working space.

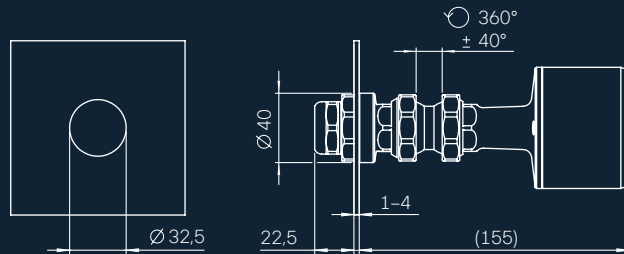

Pre-wall mounting

In the case of pre-wall mounting, the flex arm mount is seated on a foot that is screwed into place in front of the wall on the inside of the machine. Here, the data cable and sealing air hose initially run inside the working space. An optional protective hose can enclose them up to the wall penetration.

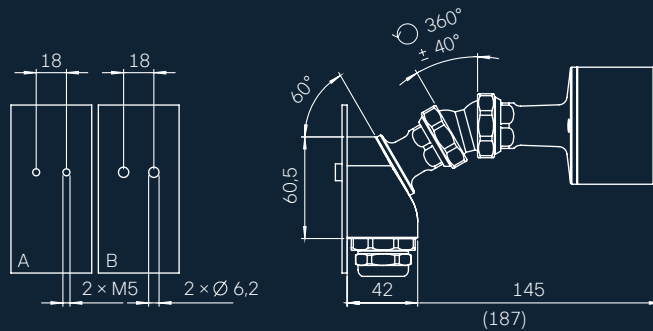

Magnetic mounting

The magnetic flex arm mount is perfect for temporary installation or for finding the perfect position of the camera head in the interior. Here, the camera head is simply attached to any position on the sheet metal wall with the help of a strong magnet.

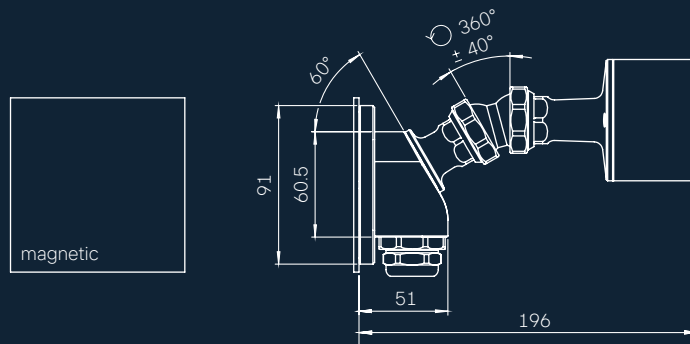

Mounting directly on the headstock

Mounting directly on the headstock allows all processes to be observed from the perspective of the tool (Tool View). Only the Rotoclear C2 offers you this revolutionary perspective.





Benefits of headstock mounting

Mounting on the headstock allows you to observe the machining processes at close range: the tool always remains in full view. This means that you will not miss a single detail of the machining process.



Installation

The space-saving and robust design of the camera head allows it to be mounted directly on the headstock in many machine solutions. Ideally, the machine manufacturer should plan for this integration when designing the machine.

If you are interested in the Tool View installation please contact your machine manufacturer. We will be happy to assist and support you with this installation.

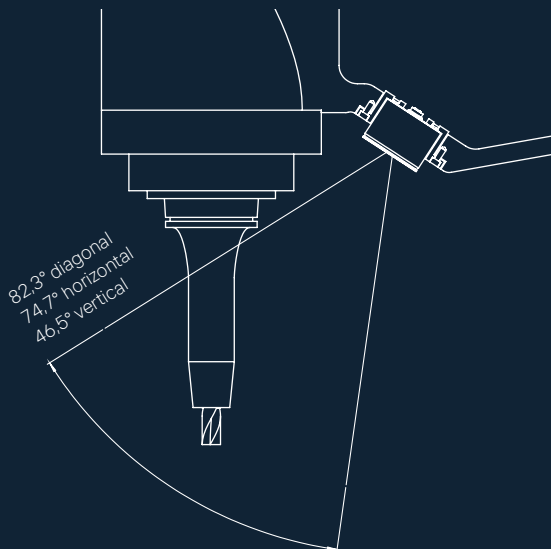

Custom mounting options

Custom mounting options are available.

Questions? Just get in touch with us.

ROTO  CLEAR

