

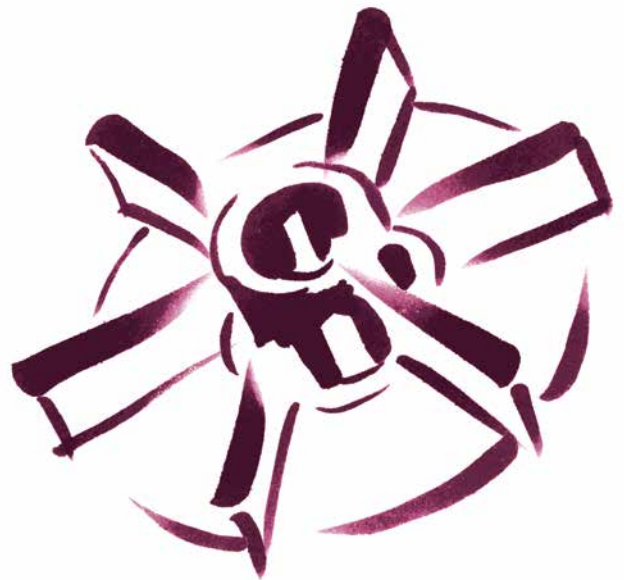

Competence in Wheel Blasting Technology



Finding Solutions Together

AGTOS was founded in 2001 by specialists from different fields in wheel blasting technology.

All of them share an enthusiasm for this type of surface treatment with its manifold possibilities.

The principle idea is to provide users with everything they need for this shot blasting technology:

New machines, pre-owned machines, service and spare parts – even for machines from other manufacturers.

This concept is the basis for our guiding principle, “Competence in shot blasting technology”.

With individual solutions which are usually developed in close cooperation with our customers, we continue to come closer to achieving this goal.

We are supported by highly motivated, loyal and competent employees and by external parties such as (technical) universities, associations and our suppliers.

Together, we will continue to work towards a successful future.





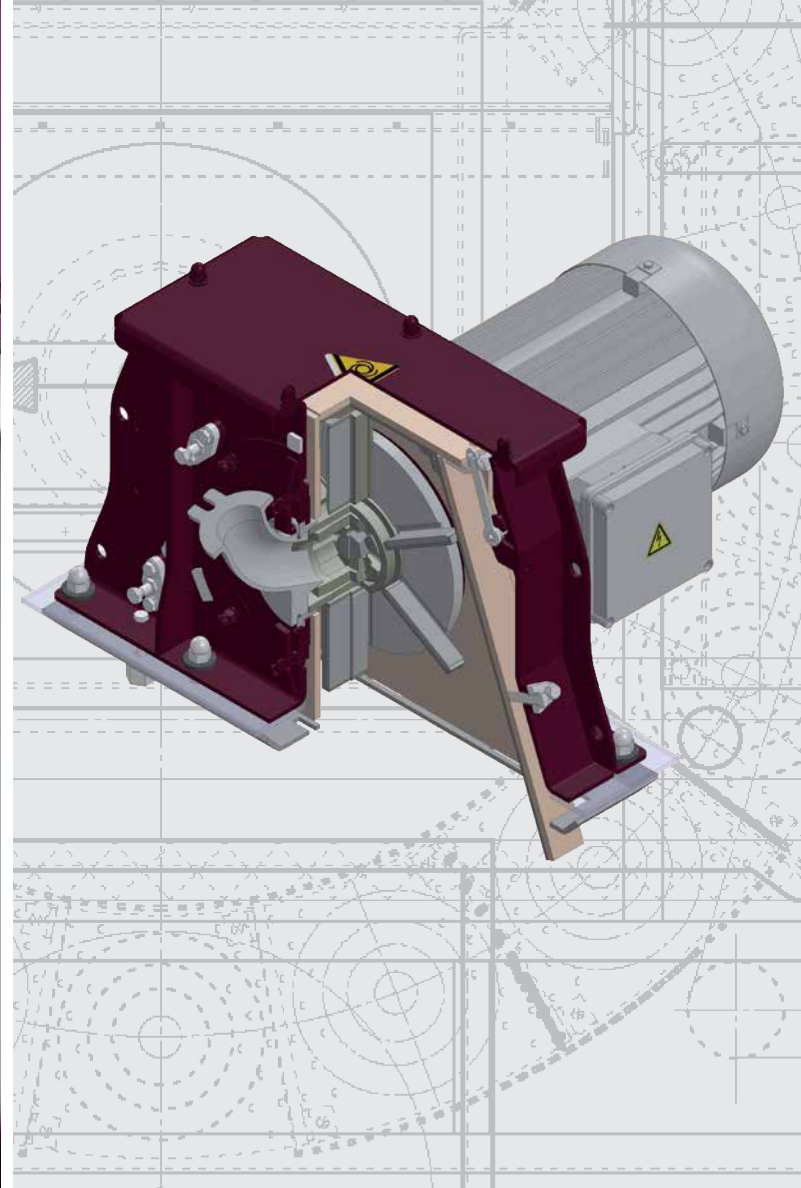

Advanced Technology

Our technology is characterized by well-thought out concepts and their further development in a practical context. We would like to illustrate this based on the two most important modules.

AGTOS high performance turbines have proven themselves on the market to be robust, economically efficient and maintenance-friendly. They are available with different turbine wheel diameters and a variety of spare and wear materials (e. g. hard metal). **AGTOS** high performance turbines are very popular for modernizing conventional shot-blasting machines as well.

AGTOS cartridge filter units are easy to maintain. The cartridges are conical shaped and coarsely folded. This promotes better inflow and cleaning of dust. And for waste disposal, only the polyester coating has to be replaced. This saves on costs and improves the environment.



Conscientious Construction

Solutions and concepts not only have to be developed, but also implemented.

AGTOS has engineers and technicians who have been working in shot blasting technology for many years. Their cooperation with younger colleagues who question things and introduce new ideas is what makes us different.

Modern construction software in the 2D and 3D field supports our work. This way, we can adapt an ideal solution for our customers in their existing buildings and sometimes, even in existing foundations/pits.

Comprehensive Planning

We gladly offer our know-how and, in addition to shot blasting technology, we also provide integration of machines and systems we supply into the complete process.

The example (below) illustrates a foundry work piece being finished. The cast pieces, regardless of their geometry, are laid down or hung up on manganese-steel frames by means of a manipulator (1). After passing a cooling tunnel (2), they are freed from moulding sand and burrs in a double chamber overhead rail shot blast machine (3) and blown-off after the blasting process (4). Manual finishing follows (5) and afterwards packaging. The process is monitored on the panel (6).



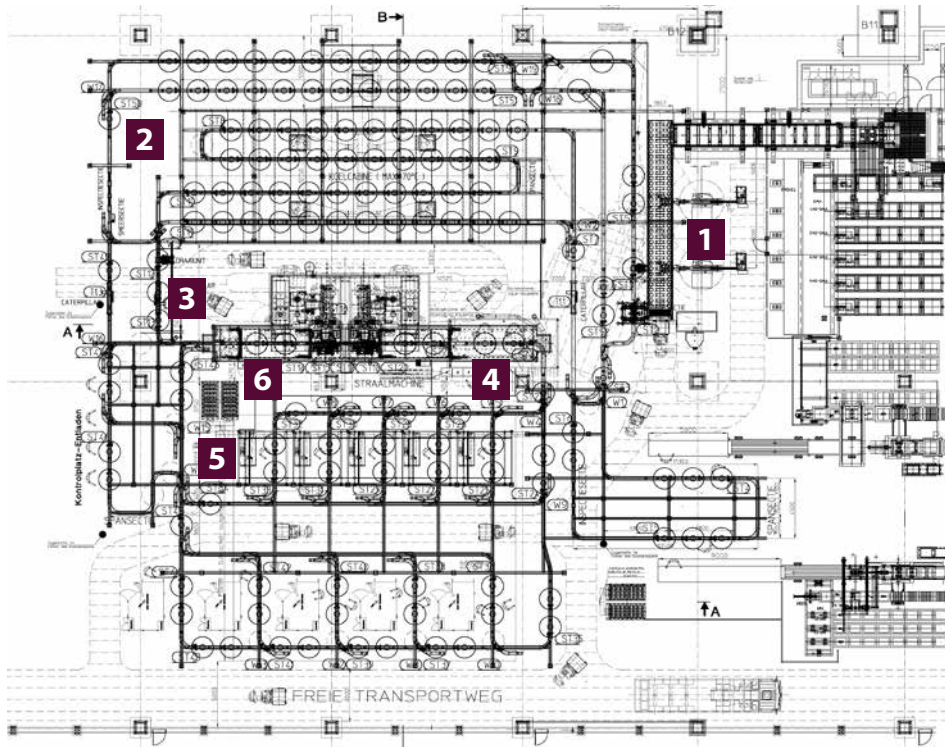

Various Concepts

In steel mill and rubber belt tumble shot blast machines, work pieces to be blasted are gently rotated on an endless rubber or steel tumble belt and are uniformly exposed to the abrasive stream for the entire blasting time. Unloading can be effected directly into different containers or onto a transport belt.



Roller conveyor shot blast machines are used to descale and derust profiles, sheets and fabrications. Using cross conveyors, a roller conveyor system can be linked with individual process steps, such as blasting, preservation, sawing and drilling.





Rotary table shot blasting machines are built in different sizes and designs. For shot-peening the automotive industry prefers to use satellite rotary table shot blast machines. Reduced cycle times and reliable blasting results are the result. In addition, they enable automation of the process.



Diabolo shot blast machines are used to descale and derust pipes, bars and round sections. As an option, the pipes are freed from the dust and abrasive by means of blowing devices. The special conveyor technology perfectly integrates these machines into the production process. This increases flexibility and ensures a higher output.

Belt shot blast machines are typically used for the treatment of metal or concrete parts. Different types and sizes offer the greatest possible flexibility.



Wire mesh conveyor shot blast machines are used for the treatment of a wide range of work pieces. The advantage is that the parts are blasted from both sides at the same time.



Walking beam shot blast machines are used for the treatment of sensitive work pieces. The photo shows quick-release axles prior to blasting.



Overhead rail shot-blast machines are suitable for a wide range of applications. The work pieces are manually hung up or laid down. The blasting process can be effected in an ideal way by changing the rotational direction and by oscillation of the hangers in front of the turbines.



In **drum shot blast machines** small work pieces are blasted as bulk goods. Thus they can be used in production lines or for stand-alone configurations.



Travelling grate shot blast machines are designed for gentle transport of all kinds of work pieces. In this case we show springs being shot peened.

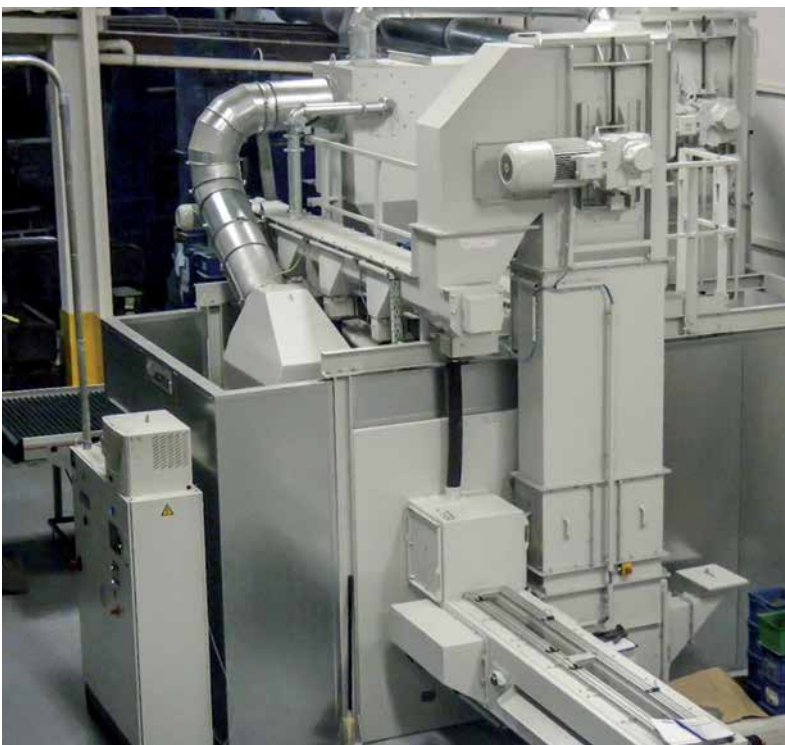

Continuous overhead rail shot blast machines are supplied in several sizes and designs as well. They enable continuous treatment and are thus designed for the use in production lines.

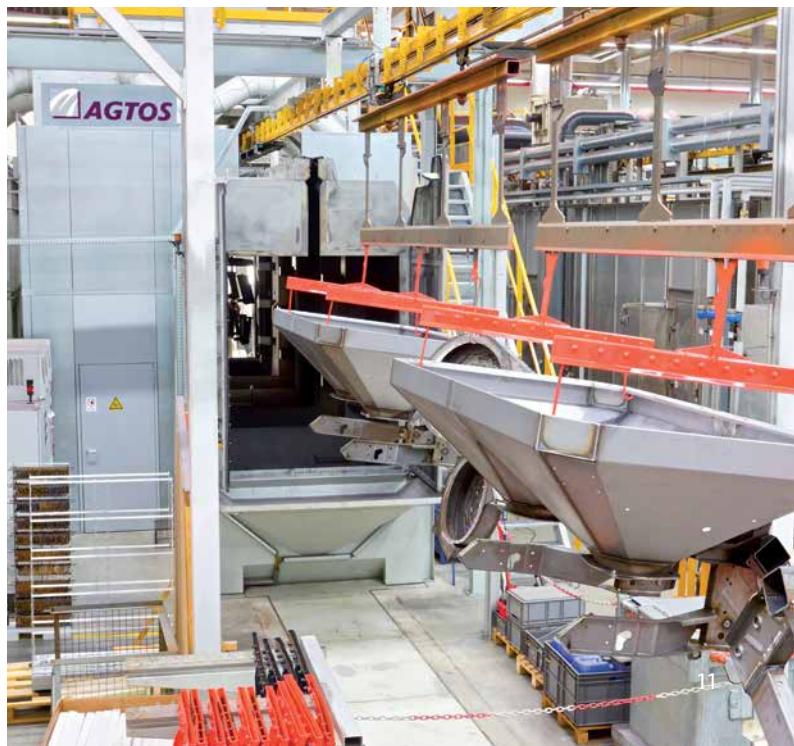



Modernization That Measures Up



Pre-owned shot blast machines are stored and in case of a project are refurbished according to demand, and are adapted to the new requirements and painted.

This allows the user to receive a machine appropriate for his needs at a favourable price. Many customers bridge production and supply shortages with pre-owned machines. Flexibility in the sales department (leasing, rental) and in the technology (quick provision and delivery) as well as the complete service including the supply of spare parts are possible.



Professional Service

We place special value on perfect service. And not just for **AGTOS** shot blast machines but also for many other manufacturers.

Our services include:

- Spare parts
- Modernization
- (Remote) maintenance
- Repairs
- Inspection
- Consultation



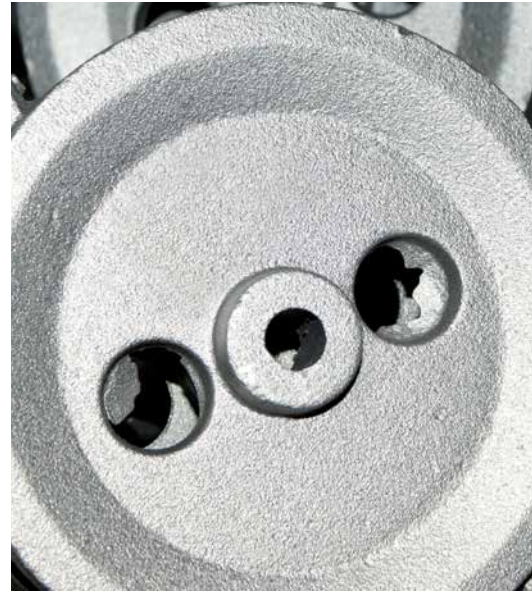

Perfect Results

Based on the work piece, the blasting task, the spatial conditions and other specifications, we develop a solution for all blasting tasks, often in close cooperation with the customer.





Securing Success

The **AGTOS** plant in Emsdetten (photo bottom, left) and Konin (photo bottom, right) secure our success. In addition to investment in the most current hardware and software, we are constantly expanding the production facilities. A new factory hall with bridge cranes and workshop pit as well as a new office building were recently built at the Konin plant.



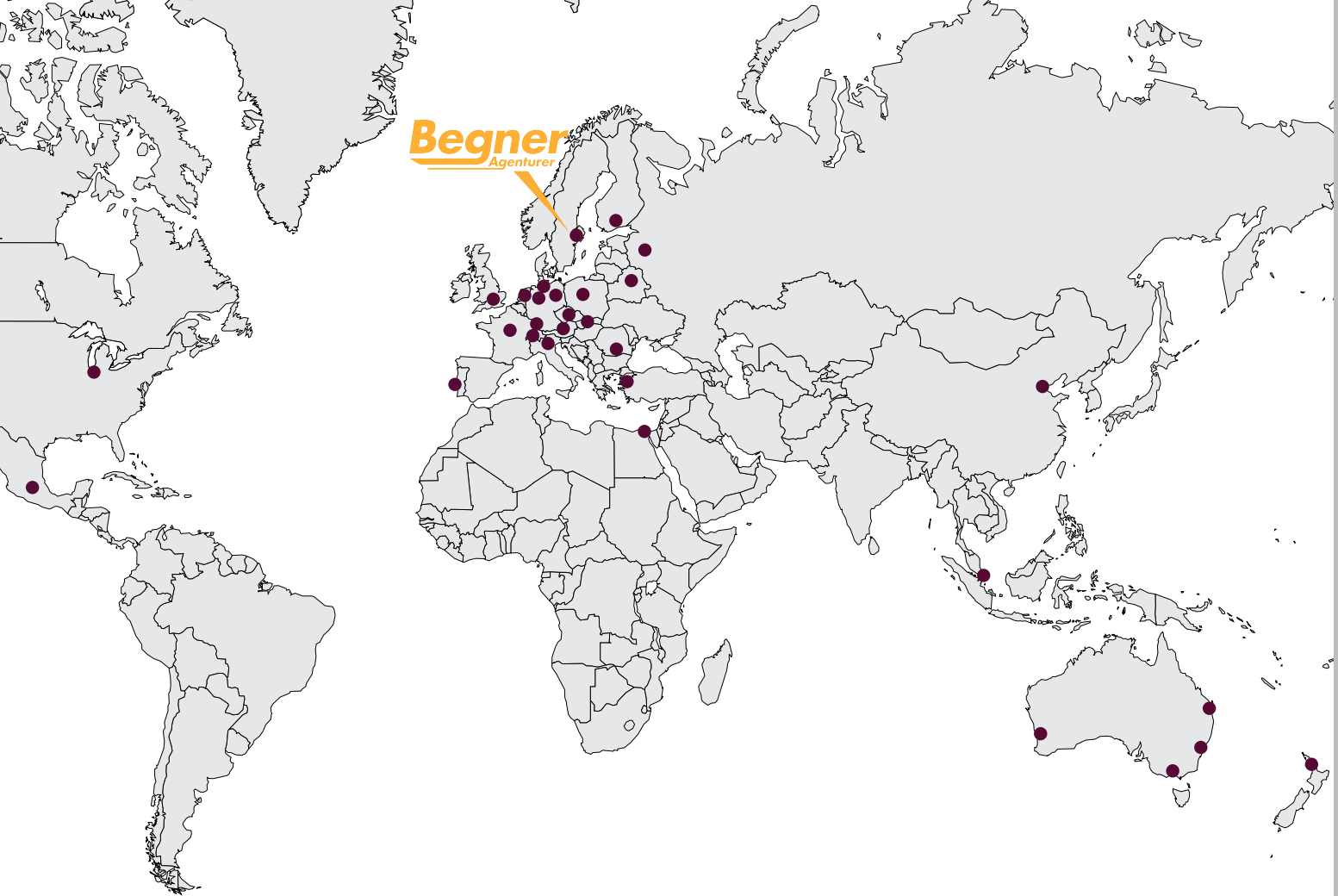

The **AGTOS** distribution network consists of sales agents in many countries and regional sales partners in all important industrial regions. You can always find current contact information on our website at www.agtos.com



Begner Agenturer
Representing AGTOS in
Scandinavia
Samuelsdalsv.2
SE-791 61 Falun
Tel.: +46(0)23-160 20
info@begner.com
www.begner.se



AGTOS
Gesellschaft für technische
Oberflächensysteme mbH
Gutenbergstraße 14
D-48282 Emsdetten
Tel.: +49(0)2572 96026-0
info@agtos.de
www.agtos.com