

**Strumento Multifunzione
per reti bassa tensione
4 moduli**

Linea trifase 80...500V (fase-fase)
Inserzione su TA dedicati
Rapporto TA e TV esterni programmabile
Energia attiva cl.0,5
Uscita impulsi 
Comunicazione RS485 protocollo
ModBus RTU/TCP o BACNET
Diagnostica, correzioni sequenza fasi

Interfacce esterne:
Comunicazione Ethernet (NT809)

**Network monitor
for low voltage
4 module**

3-phase line 80...500V (phase-phase)
Connection on dedicated CT
Programmable external CT and VT ratio
Active energy class 0,5
Pulse output
RS485 communication by
ModBus RTU/TCP or BACNET protocol
Phase sequence correction, diagnostics

External interfaces:
Ethernet communication (NT809)

Nemo D4-Le

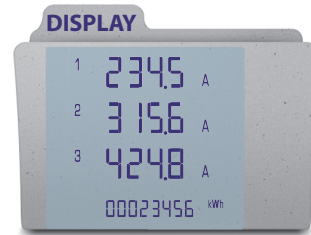
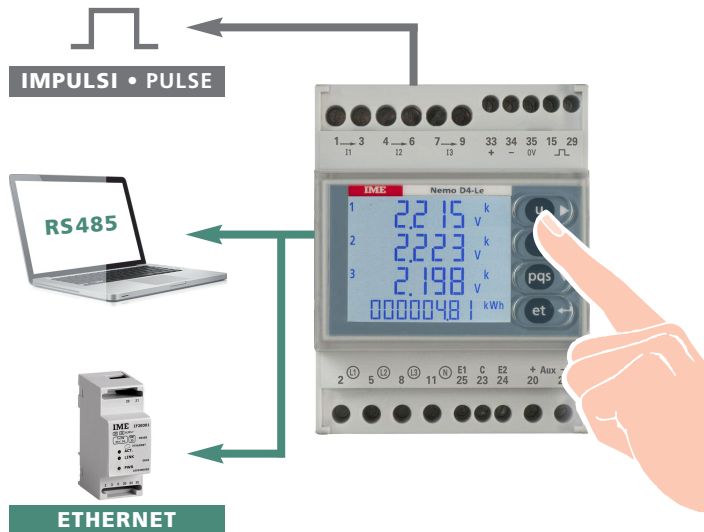

- ▶ **Tensione di fase e concatenata**
Phase and linked voltage
- ▶ **Tensione min. e max. di fase**
Min. and max. phase voltage
- ▶ **Corrente di fase e di neutro**
Neutral and phase current
- ▶ **Corrente media e valore max. corrente media**
Current demand and current max. demand
- ▶ **Frequenza**
Frequency
- ▶ **Fattore di potenza**
Power factor
- ▶ **Potenza attiva, reattiva apparente**
Active, reactive phase power
- ▶ **Potenza media e valore max. potenza media**
Power demand and power max. demand
- ▶ **Energia attiva e reattiva positiva e negativa, totale e parziale**
Total and partial, positive and negative active and reactive energy
- ▶ **Energia attiva tariffaria, 4 tariffe**
Tariff active energy, 4 tariffs
- ▶ **Ore e minuti di funzionamento**
Working hours and minutes
- ▶ **THDV e THDI**
THDV and THDI
- ▶ **Analisi armonica**
Harmonic analysis
- ▶ **Fattore di cresta tensione e corrente**
Voltage and current crest factor
- ▶ **Angolo di fase tra corrente e tensione**
Phase angle between current and voltage
- ▶ **Angolo di fase tra le correnti**
Phase angle between currents
- ▶ **Angolo di fase tra le tensioni**
Phase angle between voltages
- ▶ **Conteggio impulsi, 2 ingressi**
Pulse count, 2 input

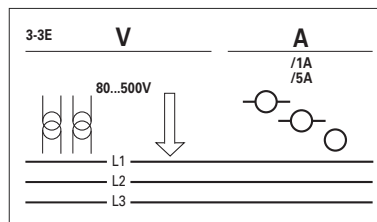
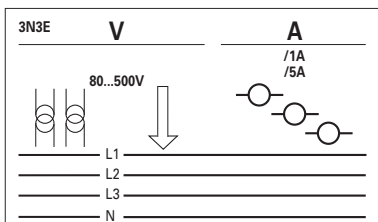
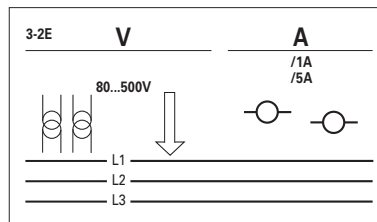
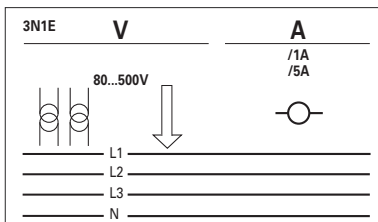
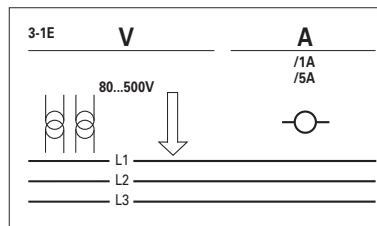
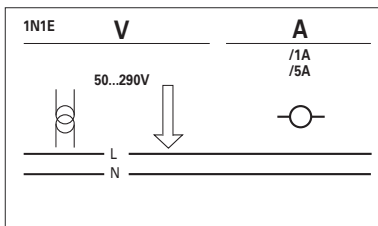

		MODELLO MODEL	Nemo D4 Le	
		LINEA NETWORK	bt / LV	
INGRESSO INPUT	CONNESSIONE CONNECTION	Monofase / Single-phase	4	
		Trifase, carico equilibrato Three-phase, balanced load	4	
		Trifase, carico squilibrato Three-phase, unbalanced load	4	
	DIAGNOSTICA, CORREZIONI SEQUENZA FASI / PHASE SEQUENCE CORRECTION, DIAGNOSTIC			4
	VALORI NOMINALI RATED VALUE	Tensione / Voltage		100 - 400V
		Corrente / Current		1 + 5A
	INGRESSO CORRENTE INPUT CURRENT	TA dedicati / Dedicated CT		4
		Isolato / Insulated		
	RAPPORTO PROGRAMMABILE PROGRAMMABLE RATIO	TV (kTV) / VT (kVT)		1...10
		TA/CT	Portate / Ranges	
I _{pn} / I _{sn}				1...9'999
max. kTV x kTA / max. kVT x kCT			99'990	
Shunt				
ENERGIA ATTIVA ACTIVE ENERGY	Precisione / Accuracy EN/IEC61557-12		cl.0,5	
	Precisione energia cc Energy accuracy dc			
	Positiva, totale e parziale Positive, total and partial		4	
ENERGIA REATTIVA REACTIVE ENERGY	Negative, totale / Negative total		4	
	Precisione / Accuracy EN/IEC61557-12		cl.1	
	Positiva, totale / Positive, total		4	
	Positiva, parziale / Positive, partial		4	
TENSIONE VOLTAGE	Negativa, totale / Negative, total		4	
	di Fase e concatenata / Phase and linked		4	
CORRENTE CURRENT	di Fase e di neutro (calcolata) Phase and neutral (computed)		4	
	di Neutro (misurata) Neutral (measured)			
	Media-medio massima di fase Phase demand and max. demand		4	
FATTORE DI POTENZA POWER FACTOR	Trifase / Three-phase		4	
	Di fase / Phase		4	
POTENZA POWER	Attiva, reattiva, apparente Active, reactive, apparent		4	
	Media e media massima Demand and max. demand		4	
	Attiva e reattiva di fase Phase active and reactive		4	
DISTORSIONE ARMONICA Corrente / Tensione HARMONIC DISTORTION Current / Voltage	THD		4	
	Analisi / Analysis		4	
FREQUENZA / FREQUENCY			4	
MISURA C.C. ¹ / D.C. ¹ MEASURE				
CONTORE / RUN HOUR METER			4	
SEQUENZA FASI ERRATA / WRONG PHASE SEQUENCE			4	
TEMPERATURA / TEMPERATURE				
USCITE OUTPUT	IMPULSI / PULSES		◆	
	RELE' ALLARMI / ALARM RELAYS		◆	
	RELE' ALLARMI + INGRESSI DIGITALI / ALARM RELAYS + DIGITAL INPUTS			
	ANALOGICA / ANALOGUE			
COMUNICAZIONE COMMUNICATION	RS232			
	RS485 MODBUS RTU		●	
	RS485 + MEMORIA / RS485 + MEMORY			
	PROFIBUS			
	LONWORKS			
	M-BUS			
	BACNET		●	
	ETHERNET		RS485 + IF2E011	
TRASMISSIONE RADIO 868MHz / 868MHz RADIO TRANSMISSION				

¹ Tensione, corrente, potenza, Ah positivi e negativi / ¹ Voltage, current, power, Ah positive and negative

◆ in alternativa On choice ● in alternativa On choice

CODICI DI ORDINAZIONE ORDERING CODE	USCITA OUTPUT	AL. AUSILIARIA AUX. SUPPLY	INGRESSO INPUT	
MFD4411	Impulsi energia Energy pulses	80...265Vca/ac 100...300V cc/dc	80...500V	1 e / and 5A
MFD4421	Impulsi energia + RS485 ModBus RTU Energy pulses + RS485 ModBus RTU			
MFD44B1	Impulsi energia + RS485 BACNET Energy pulses + RS485 BACNET			
MFD4412	Impulsi energia Energy pulses	20...60V cc/dc		
MFD4422	Impulsi energia + RS485 ModBus RTU Energy pulses + RS485 ModBus RTU			
MFD44B2	Impulsi energia + RS485 BACNET Energy pulses + RS485 BACNET			

LEGENDA:

- = Parametro Programmabile
- = Parametro Azzerabile

VISUALIZZAZIONE

Tipo display: cristallo liquido retroilluminato

Retroilluminazione selezionabile: 0 – 35 – 70 – 100%

Riduzione automatica della retroilluminazione (al valore selezionato) dopo 20 secondi circa di inattività della tastiera

Retroilluminazione 100% alla prima pressione sulla tastiera

Punti di lettura: 10'000 4 cifre (altezza cifre 12mm)

Unità ingegneristica: visualizzazione automatica in funzione dei rapporti TA e TV impostati

Risoluzione: automatica

Punto decimale: automatico

Aggiornamento display: 1 lettura/s

Conteggio energia: 8 cifre

La visualizzazione è suddivisa in 4 menù, accessibili con i relativi tasti funzione:



Le pagine di visualizzazione variano in funzione della misura programmata

PARAMETRI PROGRAMMABILI

Programmazione: tramite tastiera frontale touc-screen, 4 tasti

Accesso programmazione: protetto da password

Menù programmazione: suddiviso su due livelli

LIVELLO 1

- Pagina visualizzazione personalizzata
- Connessione
- Tempo integrazione corrente/potenza media
- Retroilluminazione display
- Avvio conteggio contaore
- Comunicazione RS485
- Funzione uscita relè (impulsi o allarme)

LIVELLO 2

- Modalità conteggio energia
- Rapporto TA e TV esterni

MODALITÀ CONTEGGIO ENERGIA

4 modalità selezionabili: sincrona, asincrona, tariffaria, contaimpulsi

LEGEND:

- = Programmable Parameter
- = Reset Parameter

DISPLAY

Type of display: backlighted liquid crystal

Selectable backlighting: 0 – 35 – 70 – 100%

Backlighting automatic reduction (to the selected value) after approximately 20 seconds of keyboard idle

100% backlighting after first pressure on the keyboard

Reading points: 10.000 4 digits (digit height 12mm)

Engineering unit: automatic display according to the loaded VT and CT ratios

Resolution: automatic

Decimal point: automatic

Display updating: 1 reading/s

Energy count: 8 digits

Display is subdivided into 4 menus which are accessible through the relevant function keys:



Display pages change according to the programmed measuring mode

PROGRAMMABLE PARAMETERS

Programming: through touch-screen front keyboard, 4 keys

Programming access: password-protected

Programming menu: subdivided on two levels

LEVEL 1

- Customized display page
- Connection
- Average power/current delay time
- Display backlighting
- Lapsed time count start
- RS485 communication
- Relay output function (pulses or alarm)

LEVEL 2

- Energy count mode
- External voltage or current transformer ratio

ENERGY COUNT MODE

4 selectable modes: synchronous, asynchronous, tariff, pulse counting

	Conteggio Energia Parziale Partial Energy Count	Energia 4 Tariffe Energy 4 Tariffs	Conteggio Impulsi Pulse Counter
SINCRONA Synchronous	Attivato da ingressi digitali Activated by digital inputs	—	—
ASINCRONA Asynchronous	Sempre attivo Always active	—	—
TARIFFARIA Tariff	—	Commutazione tariffa con ingressi digitali Tariff switching with digital inputs	—
CONTAIMPULSI Pulse counting	Sempre attivo Always active	—	Attivato da ingressi digitali Activated by digital inputs

PAGINE VISUALIZZAZIONE MODALITA'

SINCRONA - ASINCRONA - CONTAIMPULSI

PAGES DISPLAYING

SYNCHRONOUS - ASYNCHRONOUS - PULSE COUNTING

TENSIONE di fase e concatenata VOLTAGE phase and linked	CORRENTE di fase e di neutro CURRENT phase and neutral	POTENZA TRIFASE attiva, reattiva, apparente, distorcente¹ THREE-PHASE POWER active, reactive, apparent, distorting¹	FATTORE DI POTENZA di fase e trifase POWER FACTOR phase and three-phase
✗ TENSIONE MINIMA di fase MINIMUM VOLTAGE phase	CORRENTE MEDIA di fase CURRENT DEMAND phase	POTENZA FASE attiva, reattiva, apparente PHASE POWER active, reactive, apparent	ANGOLO DI FASE TENSIONE-CORRENTE di fase e trifase PHASE ANGLE CURRENT-VOLTAGE phase and three-phase
✗ TENSIONE MASSIMA di fase MAXIMUM VOLTAGE phase	✗ PICCO CORRENTE MEDIA di fase MAX. CURRENT DEMAND phase	POTENZA MEDIA attiva, reattiva, apparente POWER DEMAND active, reactive, apparent	FREQUENZA FREQUENCY
DISTORSIONE ARMONICA TENSIONE di fase o concatenata VOLTAGE HARMONIC DISTORTION phase or linked	MEDIA DELLE 3 CORRENTI AVERAGE CURRENT $\frac{I1 + I2 + I3}{3}$	✗ PICCO POTENZA MEDIA attiva, reattiva, apparente MAX. POWER DEMAND active, reactive, apparent	✗ CONTAORE RUN HOUR METER
ANALISI ARMONICA² di fase o concatenata H03/05/07/09 HARMONIC ANALYSIS² phase or linked	DISTORSIONE ARMONICA CORRENTE di fase CURRENT HARMONIC DISTORTION phase		ENERGIA ATTIVA TOTALE Positiva e Negativa TOTAL ACTIVE ENERGY Positive and Negative
FATTORE DI CRESTA CREST FACTOR	ANALISI ARMONICA² di fase H03/05/07/09 HARMONIC ANALYSIS² phase		ENERGIA REATTIVA TOTALE Positiva e Negativa TOTAL REACTIVE ENERGY Positive and Negative
ANGOLO DI FASE fra le tensioni PHASE ANGLE between voltages	FATTORE DI CRESTA CREST FACTOR		✗ ENERGIA ATTIVA PARZIALE Positiva e Negativa PARTIAL ACTIVE ENERGY Positive and Negative
	ANGOLO DI FASE fra le correnti PHASE ANGLE between currents		✗ ENERGIA REATTIVA PARZIALE Positiva e Negativa PARTIAL REACTIVE ENERGY Positive and Negative
			✗ CONTEGGIO IMPULSI Stato Ingresso Impulsi PULSE METERING State of Pulse Input

TARIFFARIA

TARIFF

TENSIONE di fase e concatenata VOLTAGE phase and linked	CORRENTE di fase e di neutro CURRENT phase and neutral	POTENZA TRIFASE attiva, reattiva, apparente, distorcente¹ THREE-PHASE POWER active, reactive, apparent, distorting¹	FATTORE DI POTENZA di fase e trifase POWER FACTOR phase and three-phase
✗ TENSIONE MINIMA di fase MINIMUM VOLTAGE phase	CORRENTE MEDIA di fase CURRENT DEMAND phase	POTENZA FASE attiva, reattiva, apparente PHASE POWER active, reactive, apparent	ANGOLO DI FASE TENSIONE-CORRENTE di fase e trifase PHASE ANGLE CURRENT-VOLTAGE phase and three-phase
✗ TENSIONE MASSIMA di fase MAXIMUM VOLTAGE phase	✗ PICCO CORRENTE MEDIA di fase MAX. CURRENT DEMAND phase	POTENZA MEDIA attiva, reattiva, apparente POWER DEMAND active, reactive, apparent	FREQUENZA FREQUENCY
DISTORSIONE ARMONICA TENSIONE di fase o concatenata VOLTAGE HARMONIC DISTORTION phase or linked	MEDIA DELLE 3 CORRENTI AVERAGE CURRENT $\frac{I1 + I2 + I3}{3}$	✗ PICCO POTENZA MEDIA attiva, reattiva, apparente tariffa 1/2/3/4 MAX. POWER DEMAND active, reactive, apparent tariff1/2/3/4	✗ CONTAORE RUN HOUR METER
ANALISI ARMONICA² di fase o concatenata H03/05/07/09 HARMONIC ANALYSIS² phase or linked	DISTORSIONE ARMONICA CORRENTE di fase CURRENT HARMONIC DISTORTION phase		ENERGIA ATTIVA POSITIVA POSITIVE ACTIVE ENERGY
FATTORE DI CRESTA CREST FACTOR	ANALISI ARMONICA² di fase H03/05/07/09 HARMONIC ANALYSIS² phase		ENERGIA REATTIVA POSITIVA POSITIVE REACTIVE ENERGY
ANGOLO DI FASE fra le tensioni PHASE ANGLE between voltages	FATTORE DI CRESTA CREST FACTOR		ENERGIA ATTIVA NEGATIVA NEGATIVE ACTIVE ENERGY
	ANGOLO DI FASE fra le correnti PHASE ANGLE between currents		ENERGIA REATTIVA NEGATIVA NEGATIVE REACTIVE ENERGY
			ENERGIA ATTIVA tariffa 1/2/3/4 ACTIVE ENERGY tariff1/2/3/4

POTENZA DISTORCENTE

¹Nei sistemi trifase, normalmente la relazione fra P,Q ed S è la seguente:

$$S = V \times I = \sqrt{P^2 + Q^2}$$

Questo vale in assenza di distorsione armonica.

Ove sia presente distorsione di corrente, la relazione deve essere corretta nel modo seguente:

$$S = V \times I = \sqrt{P^2 + Q^2 + D^2}$$

dove D assume il significato di potenza "distorcente".

ANALISI ARMONICA

²Il calcolo del contenuto spettrale del segnale tiene conto anche della possibile distribuzione di inter-armoniche che tipicamente si ritrova nelle forme d'onda ciclicamente interrotte.

In questi casi non vi sono armoniche alle frequenze multiple della fondamentale ma all'interno degli intervalli fra una armonica e la successiva:

es.: 50Hz (fondamentale)

inter-armoniche: 87,5Hz (50-100Hz) o 112,5Hz (100-150Hz)

Al fine di poter presentare i dati in modo standard, il contenuto spettrale nell'esempio viene attribuito, alla frequenza intermedia più vicina ovvero 100Hz (seconda armonica).

DISTORTING POWER

¹In normal 3-phase systems, usually the relationship between P,Q and S is as in the following:

$$S = V \times I = \sqrt{P^2 + Q^2}$$

This is true when no distortion is present in the currents. When the currents have some way a harmonic contents, the formula must be corrected in this way:

$$S = V \times I = \sqrt{P^2 + Q^2 + D^2}$$

where D has the meaning "deforming" power.

HARMONIC ANALYSE

²The calculation of the harmonic contents of the incoming signal keeps in account the possible presence of inter-harmonics that normally is found when the waveform is cyclically interrupted (burst fired).

In these cases, there aren't any harmonics at frequencies multiple of the fundamental but in the ranges between two consecutive values:

eg.: 50Hz (fundamental)

inter-harmonics: 87,5Hz (50-100Hz) or 112,5Hz (100-150Hz)

To show the results in a standard way, the harmonic contents, as in the example, are correctly attributed to the nearest central harmonic in the range 50...150Hz that is 100Hz (second harmonic).

PRECISIONE IN CONFORMITA'	CONFORMITY ACCURACY WITH	EN/IEC 61557-12	
Energia attiva	Active energy	Ea	cl.0,5
Energia reattiva	Reactive energy	Erv	cl.1
Tensione	Voltage	U	cl.0,5
Corrente	Current	I	cl.0,5
Potenza attiva	Active power	P	cl.0,5
Potenza reattiva	Reactive power	Qv	cl.1
Potenza apparente	Apparent power	Sv	cl.1
Frequenza	Frequency	f	± 0,1Hz
THD (fino a 50ª armonica) Single armoniche	THD (up to 50ª harmonic) Harmonics single	THDu / THDi	cl.1

Aggiornamento misura: 5 lettura/s

Measuring updateing: 5 reading/sec

INGRESSO

 Rete: monofase, rete trifase 3 e 4 fili

INPUT

 Network: Single-phase, three-phase network 3 and 4-wire

Simbolo Symbol	Linea Network	Carico Load	N°TA esterni External CT number	Schema Diagram	Inserzione Connection
1N1E	Monofase Single-phase	–	1	S.1000/410	–
3-1E	Trifase 3 fili 3-phase 3 wires	Equilibrato Balance	1	S.1000/411	–
3N1E	Trifase 4 fili 3-phase 4 wires	Equilibrato Balance	1	S.1000/412	–
3-2E	Trifase 3 fili 3-phase 3 wires	Squilibrito Unbalance	2	S.1000/413	Aron L1-L3
				S.1000/414	–
3-3E	Trifase 3 fili 3-phase 3 wires	Squilibrito Unbalance	3	S.1000/416	Collegamento TA con punto comune, 1 ritorno CT connection with common point, 1 return
				S.1000/415	–
3N3E	Trifase 3 fili 3-phase 3 wires	Squilibrito Unbalance	3	S.1000/417	Collegamento TA con punto comune, 1 ritorno CTCT connection with common point, 1 return

Inserzione su trasformatori di corrente esterni dedicati

Tensione trifase nominale Un: 400-100V (fase-fase)

Tensione trifase: 80...500V (fase-fase)

Tensione monofase: 50 - 290V

 Rapporto TV esterno: 1...10,0 (max. tensione primaria TV 1200V)

Corrente nominale In: 5A – 1A

Sovraccarico istantaneo: 20 In/0,5s

 Rapporto TA esterno: 1...9999 (max. corrente primaria 50kA/5A – 10kA/1A)

Frequenza nominale fn: 50Hz – 400Hz (selezione automatica)

Variatione ammessa: 45...65Hz (fn 50Hz) – 360...440Hz (fn 400Hz)

Tipo di misura: vero valore efficace

Contenuto armonico: fino a 50ª armonica (45...65Hz)

Connection with external dedicated current transformers

Three-phase voltage rating Un: 400-100V (phase-phase)

Three-phase voltage: 80...500V (phase-phase)

Single-phase voltage: 50 - 290V

 External VT ratio: 1...10,0 (max. VT primary voltage 1200V)

In rated current: 5A – 1A

Instantaneous overload: 20 In/0,5s

 External CT ratio: 1...9999 (max. primary current 50kA/5A – 10kA/1A)

Fn Rated frequency: 50Hz – 400Hz (automatic selection)

Admitted variation: 45...65Hz (fn 50Hz) – 360...440Hz (fn 400Hz)

Type of measurement: true root mean square

Harmonic contents: up to the 50ª harmonics (45...65Hz)

Fattore di cresta corrente: 2

Tempo di avviamento (conteggio energia): < 5s

Autoconsumo tensione: $\leq 0,2VA$ (fase-neutro alla tensione nominale)

Autoconsumo corrente: $\leq 1VA$ (per fase alla corrente massima 6A)

 **Tempo integrazione corrente/potenza media:** 5/8/10/15/20/30/60 min.

INGRESSI DIGITALI

2 ingressi digitali attivi, con differente utilizzo in modalità conteggio selezionata

Sincrona: attivazione conteggio energia parziale attiva e/o reattiva

Asincrona: ingressi digitali non utilizzati

Tariffaria: Commutazione tariffa 1 / 2 / 3 / 4

Contaimpuls: conteggio impulsi ingresso 1 e 2

3 terminali di ingresso con punto comune (morsetti 23-24-25)

Massima tensione ingresso: 27V

Massima frequenza impulsi ingresso: 15Hz

DIAGNOSTICA, CORREZIONE SEQUENZA FASI

Nel software del dispositivo è presente un algoritmo di diagnostica e di riparazione della sequenza di inserzione voltmetrica ed amperometrica. La funzione è attivabile a richiesta con password e consente di visualizzare e modificare via software la sequenza di cablaggio a patto che le seguenti condizioni siano rispettate:

- 1) Il conduttore di neutro (nella rete a 4 fili) sia correttamente posizionato al morsetto corrispondente (normalmente numero 11).
- 2) Non siano presenti incroci di conduttori fra TA differenti (es. sulla fase 1 del dispositivo vi sia un cavo proveniente dal TA 1 e sull'altro un cavo dal TA 2).
- 3) Il fattore di potenza sia compreso fra 1 e 0,5 Induttivo per ciascuna fase.

Vedi www.imeitaly.com "SUPPORTO TECNICO".

USCITA RELÈ

Funzione uscita: impulsi energia o contatto allarme

USCITA IMPULSI ENERGIA

Uscita impulsi compatibile con S0 EN/IEC 62053-31

Optorelè con contatto SPST-NO libero da potenziale

Portata contatti: 27Vcc/ca – 50mA

 **Energia associata:** attiva o reattiva

 **Peso impulso:** 1imp/10Wh(varh) – 100Wh(varh) – 1kWh(kvarh) – 10kWh(kvarh) – 100kWh(kvarh) – 1MWh(Mvarh) – 10MWh(Mvarh)

 **Durata impulso:** 50 – 100 – 200 – 300 – 400 – 500ms

ALLARME

Optorelè con contatto SPST-NO libero da potenziale

Portata contatti: 27Vcc/ca – 50mA

 **Grandezza associabile:**

tensione di fase L1-N / L2-N / L3-N

tensione concatenata L1-L2 / L2-L3 / L3-L1

corrente di fase I1 / I2 / I3

frequenza

potenza attiva trifase

potenza reattiva trifase

 **Soglia intervento**

 **Tipo allarme:** minima o massima

 **Contatto uscita relè:** norm. aperto o norm. chiuso

 **Isteresi:** 0...20%

 **Ritardo intervento:** 0...99s

 **Ritardo ripristino:** 0...99s

COMUNICAZIONE RS485 Modbus

Isolata galvanicamente da ingresso e ausiliaria

Standard: RS485 – 3 fili

Trasmisione: asincrona seriale

Protocollo: Modbus RTU – Modbus TCP (autoriconoscimento)

 **N° indirizzo:** 1...255

Numero bit: 8

Bit di stop: 8

Bit di parità: nessuna – pari – dispari

Current peak factor: 2

Starting time (energy count): < 5s

Voltage rated burden: $\leq 0,2VA$ (phase-neutral to the rated voltage)

Current rated burden: $\leq 1VA$ (for phase to the max. current 6A)

 **Current/average power delay time:** 5/8/10/15/20/30/60 min.

DIGITAL INPUTS

2 active digital inputs, with different use according to the selected count mode

Synchronous: active and/or reactive partial energy count activation

Asynchronous: unused digital inputs

Tariff: tariff switching 1 / 2 / 3 / 4

Pulse metering: pulse metering for input 1 and 2

3 input terminals with common point (terminals 23-24-25)

Max. input voltage: 27V

Max. input pulse frequency: 15Hz

PHASE SEQUENCE CORRECTION, DIAGNOSTIC

In the software of the device IME have added a specific functionality to detect and correct many problems concerning voltage and / or current connection.

This function can be activated through password and allows to display and modify the connection sequence provided that the following conditions are respected:

- 1) The neutral wire (in a 4-wire network) is connected to the right terminal (normally number 11).
- 2) No crossings between cables connected to CTs (e.g. avoid that on phase 1 of the meter -terminals 1 and 3 - are connected some way both to CT1 and CT2).
- 3) The power factor is between 1 and 0,5 - Inductive load - for each phase.

See www.imeitaly.com "TECHNICAL SUPPORT".

RELAY OUTPUT

Output function: energy pulses or alarm contact

ENERGY PULSE OUTPUT

Pulse output compatible with S0 EN/IEC 62053-31

Optorelay with potential-free SPST-NO contact

Contact range: 27Vdc/ac – 50mA

 **Associated energy:** active or reactive

 **Weight of pulse:** 1 pulse/10Wh(varh) – 100Wh(varh) – 1kWh(kvarh) – 10kWh(kvarh) – 100kWh(kvarh) – 1MWh(Mvarh) – 10MWh(Mvarh)

 **Pulse duration:** 50 – 100 – 200 – 300 – 400 – 500ms

ALARM

Optorelay with potential-free SPST-NO contact

Contact range: 27Vdc/ac – 50mA

 **Quantities that can be associated:**

phase voltage L1-N / L2-N / L3-N

interlinked voltage L1-L2 / L2-L3 / L3-L1

phase current I1 / I2 / I3

frequency

3-phase active power

3-phase reactive power

 **Intervention threshold**

 **Type alarm:** min. or max.

 **Relay output contact:** normally open or normarmally closed

 **Hysteresis:** 0...20%

 **Intervention delay:** 0...99s

 **Reset delay:** 0...99s

Modbus RS485 COMMUNICATION

Galvanically insulated from input and auxiliary supply

Standard: RS485 – 3 wires

Transmission: serial asynchronous

Protocol: Modbus RTU – Modbus TCP (autorecognition)

 **Number of address:** 1...255

Number of bits: 8

Stop bit: 8

Parity bit: none – even – odd

- Tempo di attesa alla risposta:** 3...100ms
- Velocità trasmissione:** 4'800 – 9'600 – 19'200 – 38'400 bit/s
- Formato word messaggio Modbus:** Big Endian, Little Endian, Swap

Esempio

Messaggio richiesta: **FF 03 03 01 00 02 80 51**

Risposta:

Big Endian = **FF 03 04 01 02 03 04 XX YY**
 Little Endian = **FF 03 04 04 03 02 01 XX YY**
 Swap = **FF 03 04 03 04 01 02 XX YY**

N° massimo di apparecchi collegabili in rete: 32 (fino a 255 con ripetitore RS485)

Distanza massima dal supervisore: 1200m

COMUNICAZIONE RS485 BACNET

Isolata galvanicamente da ingresso e ausiliaria

Standard: RS485 – 3 fili

Trasmisione: asincrona seriale

Protocollo: BACNET MS-TP

N° indirizzo: 0...127

Velocità trasmissione: 9'600 – 19'200 – 38'400 – 76'800 bit/s

Numero bit: 8

Bit di stop: 8

Bit di parità: nessuna – pari – dispari

Indirizzo di rete: 0...4000

N° max. di apparecchi collegabili in rete: 32 (fino a 255 con ripetitore RS485)

Distanza massima dal supervisore: 1200m

COMUNICAZIONE Ethernet (NT809)

Realizzabile solo con i mod. **MFD4421** e **MF44422** (comunicazione RS485) + interfaccia **IF2E011** o **IF2E111** (RS485/Ethernet)

ALIMENTAZIONE AUSILIARIA

Valore nominale Uaux ca: 80...265Vca - 48Vca

Frequenza nominale fn: 50 opp. 400Hz (selezione automatica)

Frequenza di funzionamento: 45...65Hz (fn 50Hz) opp. 360...440Hz (fn 400Hz)

Autoconsumo: ≤ 2,5VA (230Vca backlight 30%)

Valore nominale Uaux cc: 100...300Vcc - 20...60Vcc

Autoconsumo: ≤ 2,5W (24Vca backlight 30%)

Protezione contro l'inversione di polarità

Answer waiting time: 3...100ms

Transmission speed: 4'800 – 9'600 – 19'200 – 38'400 bit/second

Modbus word message format: Big Endian, Little Endian, Swap

Example

Request message: **FF 03 03 01 00 02 80 51**

Risposta:

Big Endian = **FF 03 04 01 02 03 04 XX YY**
 Little Endian = **FF 03 04 04 03 02 01 XX YY**
 Swap = **FF 03 04 03 04 01 02 XX YY**

Max. number of devices that can be network-connected: 32 (up to 255 with RS485 repeator)

Max. distance from the supervisor: 1200m

BACNET RS485 COMMUNICATION

Galvanically insulated from input and auxiliary supply

Standard: RS485 – 3 wires

Transmission: serial asynchronous

Protocol: BACNET MS-TP

Number address: 0...127

Trasmision speed: 9'600 – 19'200 – 38'400 – 76'800 bit/s

Number of bits: 8

Stop BIT: 8

Parity: none – even – odd

Network address: 0...4000

Max. number of devices that can be network-connected: 32 (up to 255 with RS485 repeator)

Max. distance from the supervisor: 1200m

Ethernet COMMUNICATION (NT809)

It can be carried out just with models **MFD4421** and **MF44422** (RS485 communication) + **IF2E011** or **IF2E111** (RS485/Ethernet) interface

AUXILIARY SUPPLY

Rated value Uaux ac: 80...265Vac - 48Vac

Rated frequency fn: 50 or 400Hz (automatic selection)

Working frequency: 45...65Hz (fn 50Hz) or 360...440Hz (fn 400Hz)

Rated burden: ≤ 2,5VA (230Vac backlight 30%)

Rated value Uaux dc: 100...300Vdc - 20...60Vdc

Rated burden: ≤ 2,5W (24Vdc backlight 30%)

Protected against incorrect polarity

PROVE TESTS

Circuiti considerati <i>Considered circuits</i>
Alimentazione / Ingressi voltmetrici <i>Supply / Voltmetric inputs</i>
Ingressi misura / Comunicazione RS485 <i>Measure inputs / RS485Communication</i>
Ingressi misura / Uscita impulsi <i>Measure inputs / Pulse output</i>
Tutti i circuiti e massa <i>All circuits and earth</i>

Tensione impulso 1,2/50µs 0,5J Voltage test 1,2/50µs 0,5J	Tensione alternata valore efficace 50Hz 1min Alternating voltage r.m.s value 50Hz 1min
6kV	3kV
6kV	3kV
6kV	3kV
	4kV

ISOLAMENTO

(EN/IEC 61010-1)

Categoria di installazione: III

Grado di inquinamento: 2

Tensione di riferimento per l'isolamento: 300V (Fase - neutro)

COMPATIBILITA' ELETTROMAGNETICA

Emissione in accordo con EN / IEC 61326-1 classe B

Immunità in accordo con EN / IEC 61326-1

CONDIZIONI AMBIENTALI

Temperatura di riferimento: 23°C ± 2°C

Campo di funzionamento specificato: - 5...55°C

Campo limite per l'immagazzinamento e trasporto: - 25...70°C

Adatto all'utilizzo in climi tropicali

Massima potenza dissipata¹: ≤ 5W

¹Per il dimensionamento termico dei quadri

INSULATION

(EN/IEC 61010-1)

Installation category: III

Pollution degree: 2

Insulation voltage rating: 300V (phase - neutral)

ELETTROMAGNETIC COMPATIBILITY

Emission according to EN 61326-1 class B

Immunity according to EN 61326-1

ENVIRONMENTAL CONDITIONS

Reference temperature: 23°C ± 2°C

Specified operating range: - 5...55°C

Limit range for storage and transport: - 25...70°C

Suitable for tropical climates

Max. power dissipation¹: ≤ 5W

¹For switchboard thermal calculation

CUSTODIA

Custodia: 4 moduli DIN 43880

Montaggio: a incastro su profilato 35mm

Tipo profilato: a cappello TH35-15 (EN60715)

Materiale custodia: policarbonato autoestinguente

Grado di protezione (EN60529): IP54 frontale, IP20 morsetti

Peso: 250 grammi

PORTATA MORSETTI

INGRESSO TENSIONE

ALIMENTAZIONE AUSILIARIA

USCITE

Con capocorda: min.0,05mm² / max. 4mm²

Cavo flessibile: min.0,05mm² / max. 2,5mm²

Coppia serraggio consigliata: 0,6Nm

INGRESSO CORRENTE

Con capocorda: min.0,05mm² / max. 6mm²

Cavo flessibile: min.0,05mm² / max. 4mm²

Coppia serraggio consigliata: 1Nm

HOUSING

Housing: 4 moduli DIN 43880

Mounting: snap-on 35mm rail

Rail type: top hat TH35-15 (EN60715)

Housing material: self-extinguishing polycarbonate

Protection degree (EN60529): IP54 front frame, IP20 terminals

Weight: 250 grams

TERMINAL CAPACITY

VOLTAGE INPUT

AUX. SUPPLY

OUTPUT

With lag: min.0,05mm² / max. 4mm²

Flexible cable: min.0,05mm² / max. 2,5mm²

Tightening torque advised: 0,6Nm

CURRENT INPUT

With lag: min.0,05mm² / max. 6mm²

Flexible cable: min.0,05mm² / max. 4mm²

Tightening torque advised: 1Nm

POSIZIONE TERMINALI TERMINAL POSITION

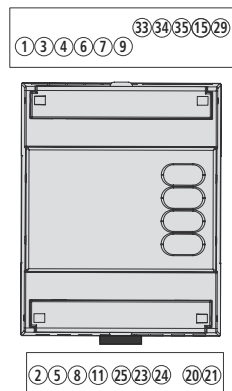

F : 0,5A gG

1n1E
Linea Monofase
Single phase network

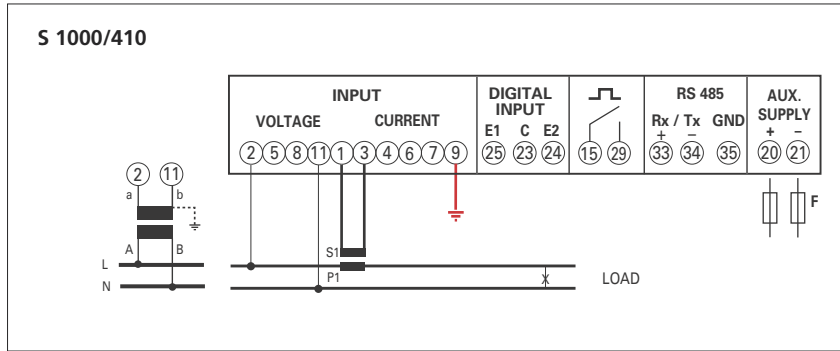

3-1E
Linea Trifase 3 Fili 1 Sistema
Three-phase 3-wires network 1 System

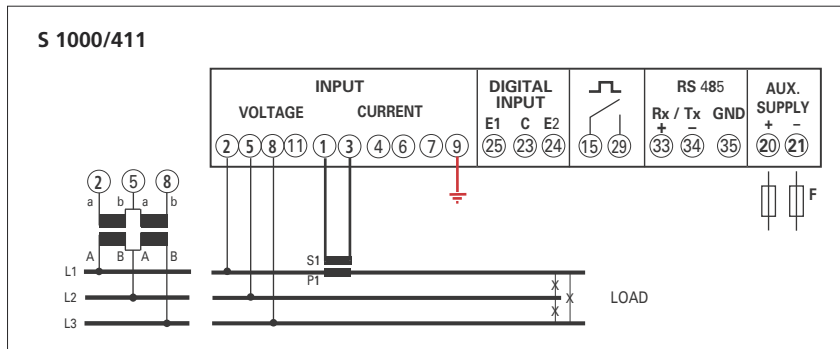

3N1E
Linea Trifase 4 Fili, 1 Sistema
Three-phase 3-wires network, 1 System

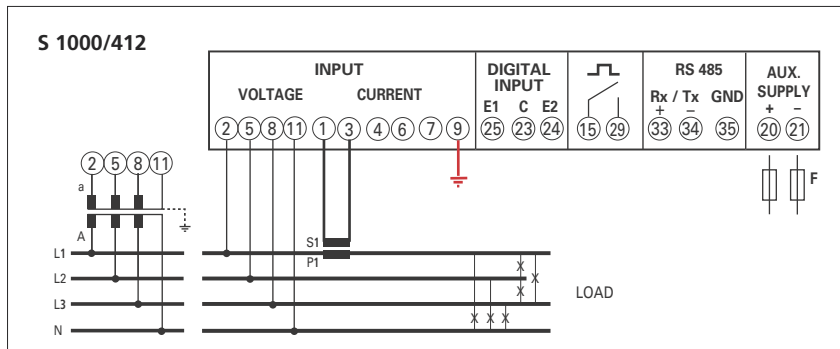

3-2E
Linea Trifase 3 fili, 2 Sistemi
Three-phase 3-wires network, 2 Systems

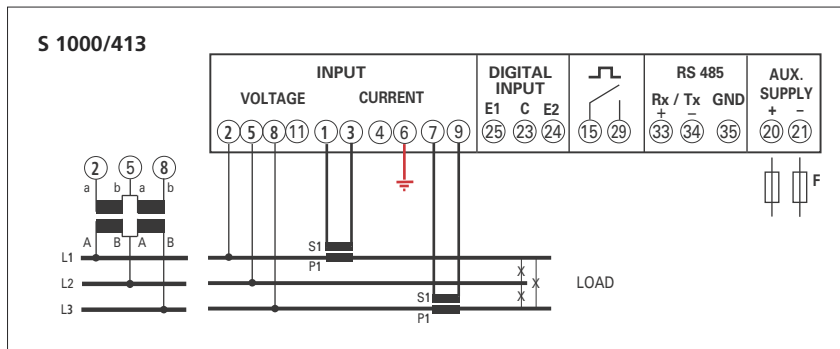

3-3E
Linea trifase 3 fili 3 Sistemi
Three-phase 3-wires network, 3 Systems

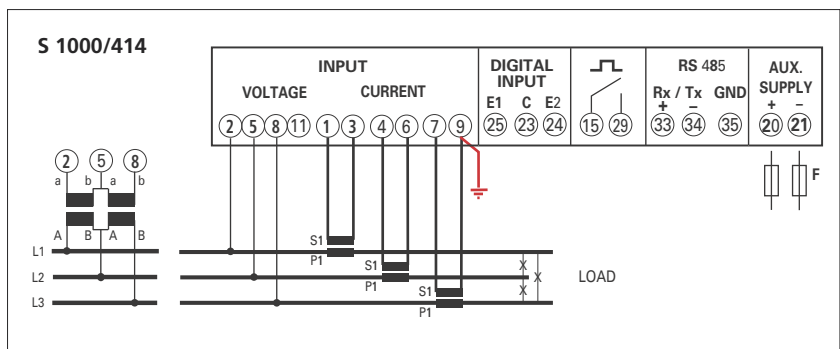

3N3E
Linea Trifase 4 fili, 3 Sistemi
Three-phase 4-wire network, 3 Systems

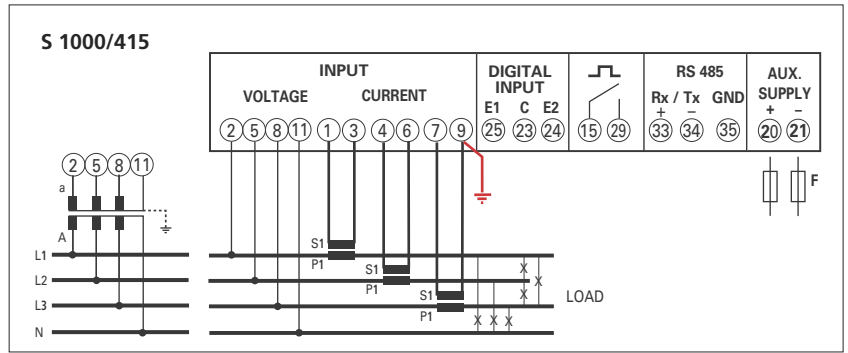

3-3E
Linea trifase 3 fili 3 Sistemi
Three-phase 3-wires network, 3 Systems

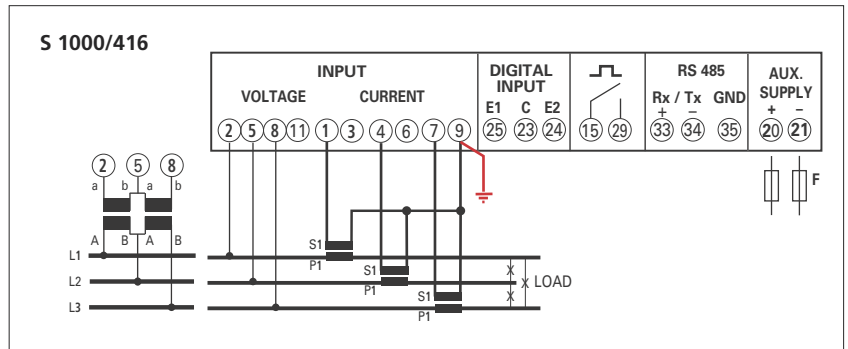

3N3E
Linea Trifase 4 fili, 3 Sistemi
Three-phase 4-wire network, 3 Systems

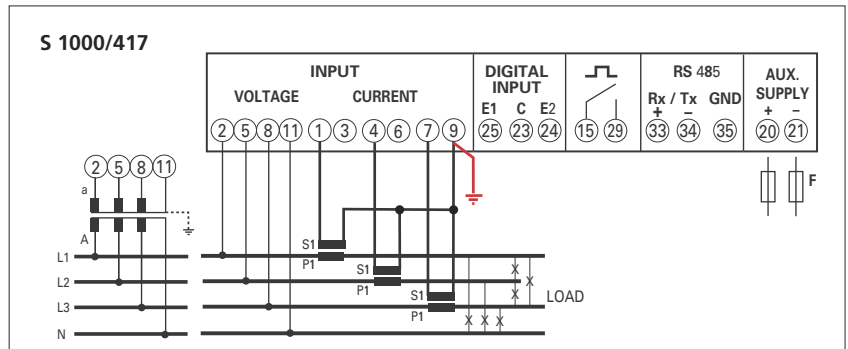

ATTENZIONE!

I collegamenti a terra riportati negli schemi di inserzione (evidenziati in rosso) sono obbligatori. Collegare alimentazione ausiliaria ai terminali 20 e 21.

ATTENTION!

The earth connections shown in the wiring diagrams (highlighted in red) are compulsory. Aux. supply must be connected to terminals 20 and 21.

DIMENSIONI DIMENSIONS

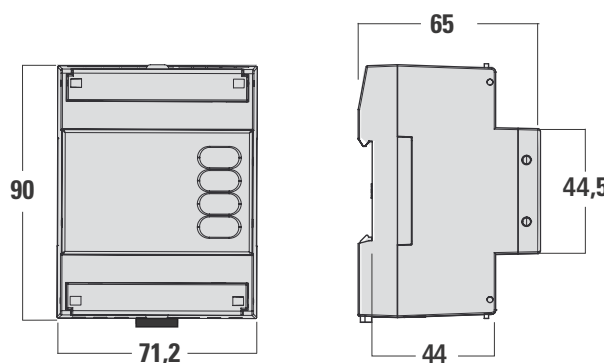

La I.M.E. S.p.A. si riserva in qualsiasi momento, di modificare le caratteristiche tecniche senza darne preavviso. / I.M.E. S.p.A. reserves the right, to modify the technical characteristics without notice.