

W50

Three-phase Electric Motor

Commercial Catalogue
IEC Market

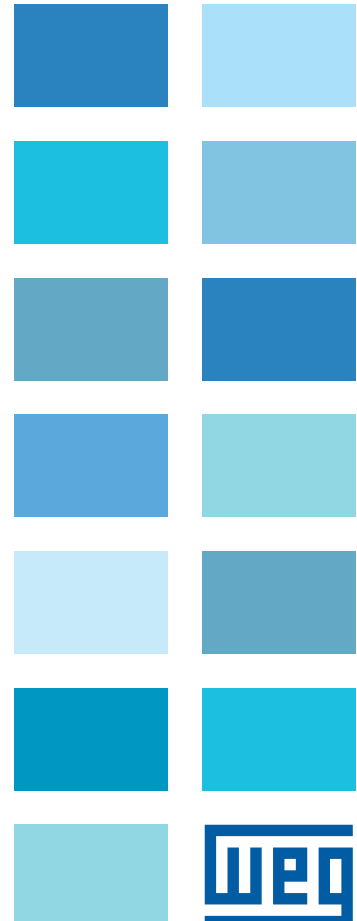
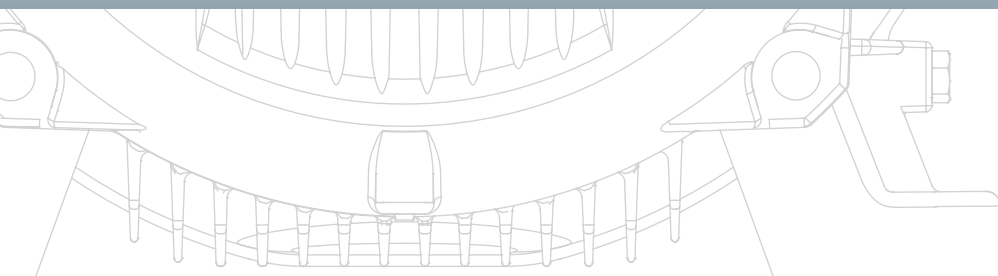
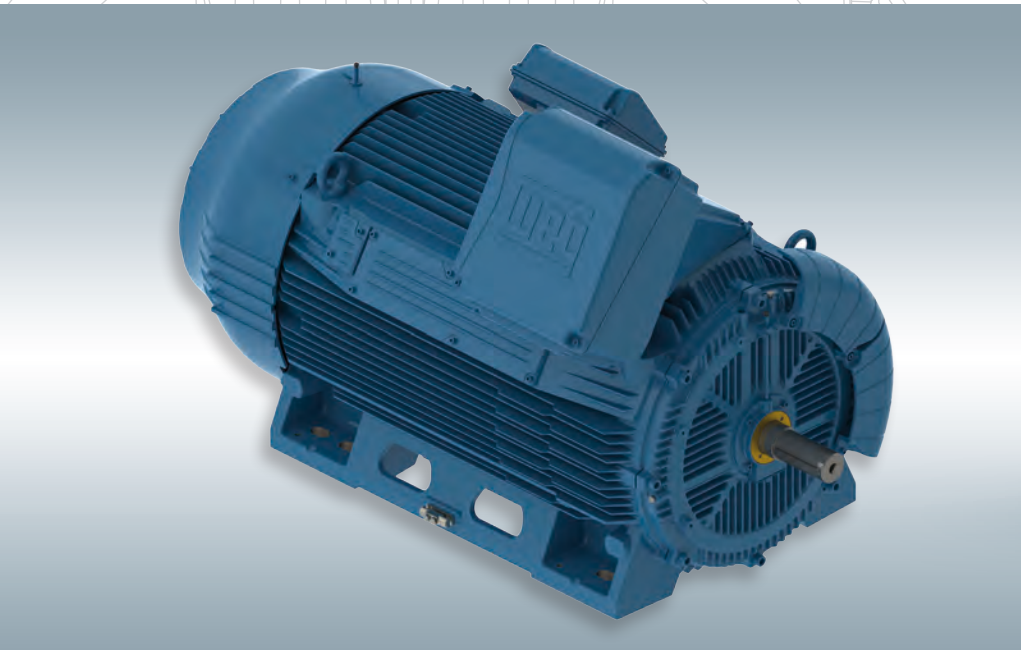
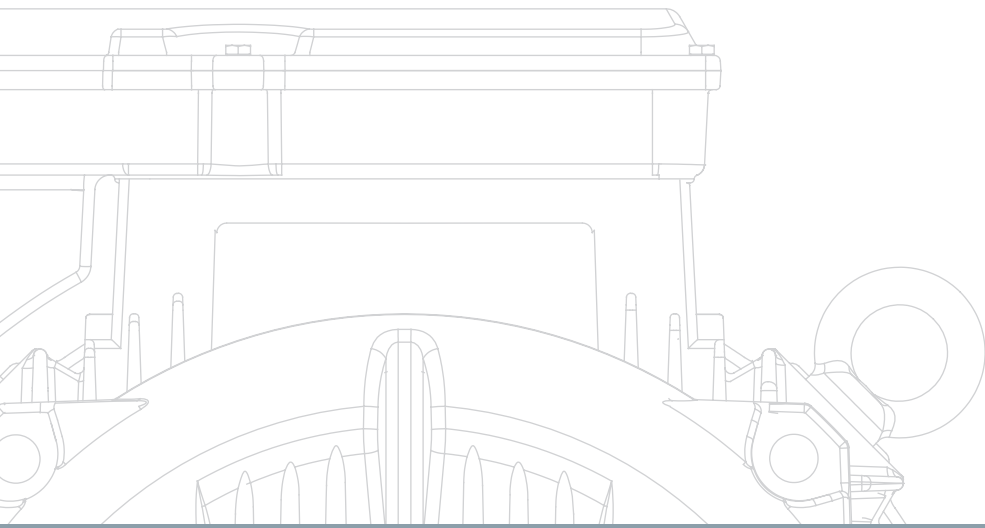

W50

WEG W50 motors offer not only **excellent performance**, but comply with the strictest **efficiency** and **safety** criteria in the most severe applications. The compact design provides **high performance**, while their robust frames ensure **low vibration levels**.

The new mechanical concept not only optimizes characteristics like mass and length, but also offers product **versatility** and **reduced maintenance**.



Standard Features

- Rated output: 75kW to 1250kW
- Number of poles: 2 to 12
- Frame sizes: 315H/G to 450J/H
- Frequency: 50 and 60 Hz
- Voltage: 380 to 6600V
- Service factor: 1,00
- Insulation class: F
- Degree of protection: IP55
- Mounting: B3
- Cooling method: TEFC – Totally enclosed fan cooled (IC411)
- Frame, endshields, fan cover and terminal box material: FC-200 cast iron
- Shaft material: AISI 4140
- Thermal protection:
 - Windings: Pt-100 3 wire, 2 per phase
 - Bearings: Pt-100 3 wire, 1 per bearing
- Grease lubricated ball bearings
- Bearing seal: Taconite labyrinth
- Vibration Level: Grade A according IEC 60034-14
- Lubrication: Mobil Polyrex EM Grease
- Painting plan: C5 (I and M) - "High" Durability according ISO 12944
- Color: RAL 5009 (Blue)
- Dual Voltage Space Heaters
- Automatic drain plug

Optional Features

- Other mounting configurations: B35, V1, V5, V6 etc.
- Degree of Protection: IP56, IP65, IP66
- Cooling method: TEBC – Totally enclosed blower cooled (IC 416)
- Surrounding muffler
- Service factor: 1.15
- Bearings:
 - Sleeve bearings
 - Insulated drive end bearing for inverter duty applications
 - Cylindrical roller bearing
 - Shaft grounding brush
 - Bearings designs for vertical mounting normal and high thrust applications
- Seal: INPRO/SEAL®
- Vibration level: Grade B according IEC 60034-14
- Bearing and winding thermal protection: thermistors or thermostats
- Cable glands
- Drip proof canopy for shaft down applications
- Internal tropicalized painting
- Encoder
- Suitable for VFD applications
- Main terminal box in welded steel
- Additional terminal box: For "Y" connection with access to the neutral terminal
- Non-contact / contact thermometer with gauge
- Stainless steel fasteners



W50: Robust, compact, efficient and reliable in the most severe operating conditions.

Features and benefits

Mechanical Design

- Compact and robust frame
- Low noise levels (82 dB(A) at 3600rpm)
- Optimum efficiencies due to low mechanical losses
- Innovative design of the DE endshield fins for maximum heat dissipation
- Uniform temperature distribution across the motor frame due to the exclusive internal ventilation system
- Easy access to accessories
- State of the art air deflector on the DE endshield ensuring lower bearing temperature

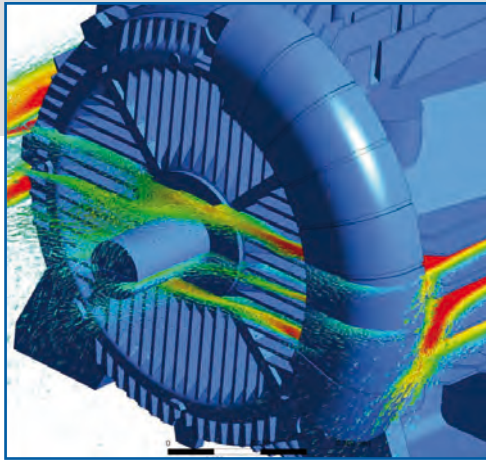

Electrical Performance

- Suitable for VFD applications
- High output/weight ratio
- Low starting current
- WISE® insulation system for low voltage motors
- VPI insulation system for medium voltage motors

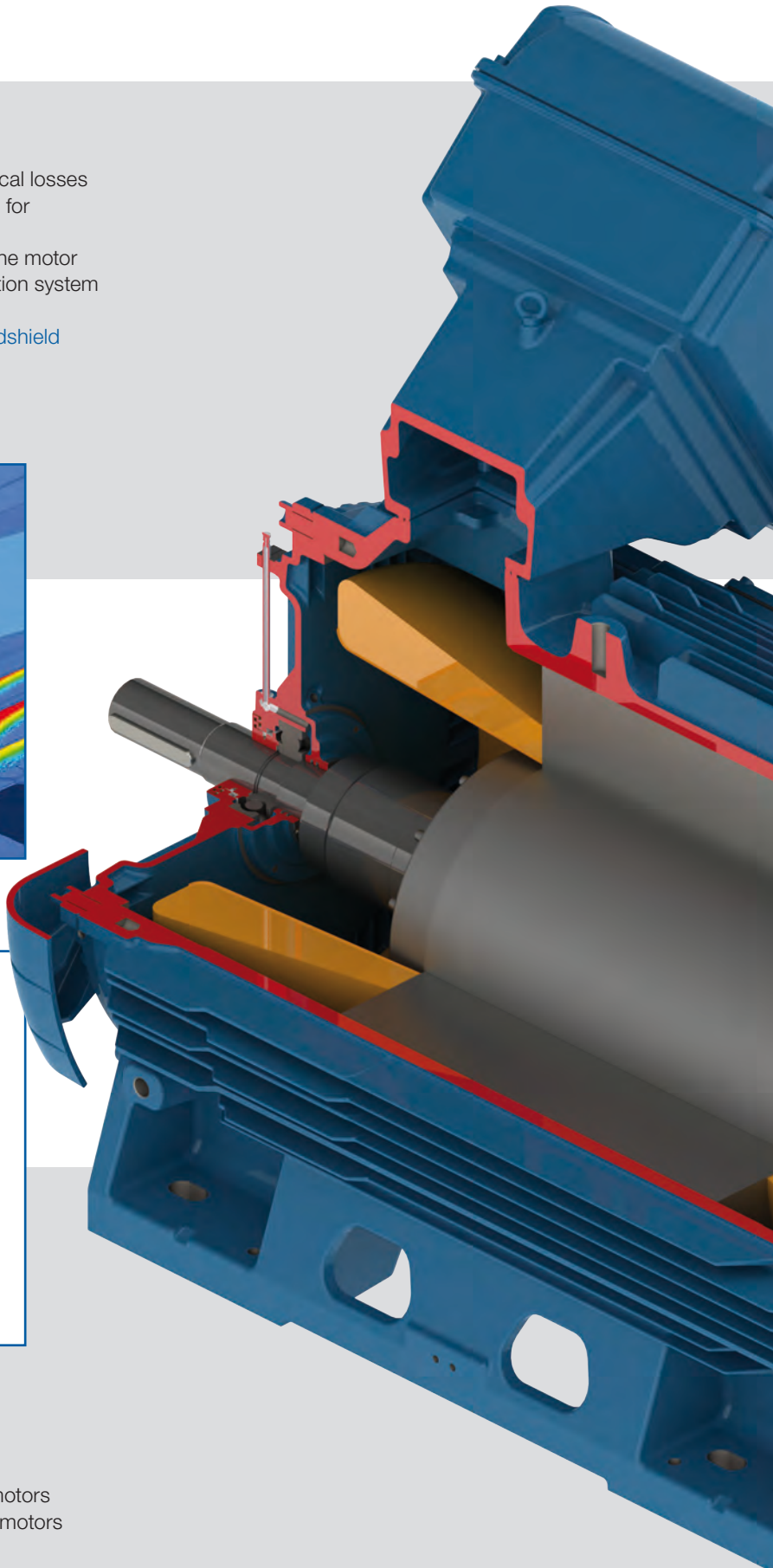

Versatility

- Modular forced ventilation kit
- Wide range of options and accessories
- Terminal box location on either left or right side

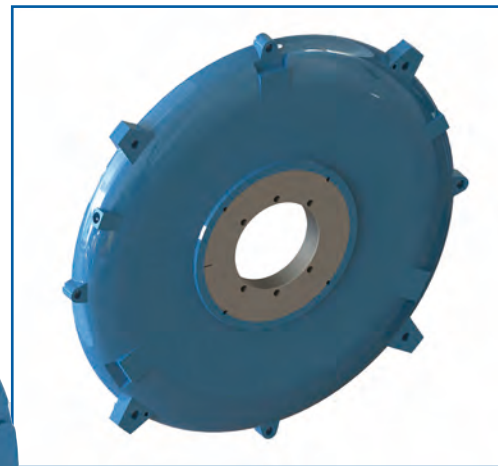
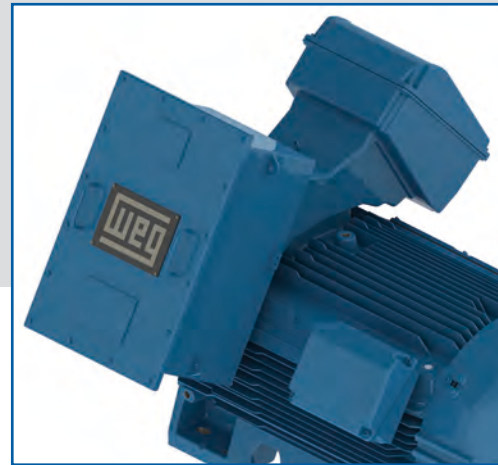

Reliability

- Insulated NDE endshield for all motors
- Wound stator winding and bearings with temperature sensors
- Low bearing temperatures ensure longer lubrication intervals and extended bearing lifetime
- Low vibration levels ensure longer motor lifetime

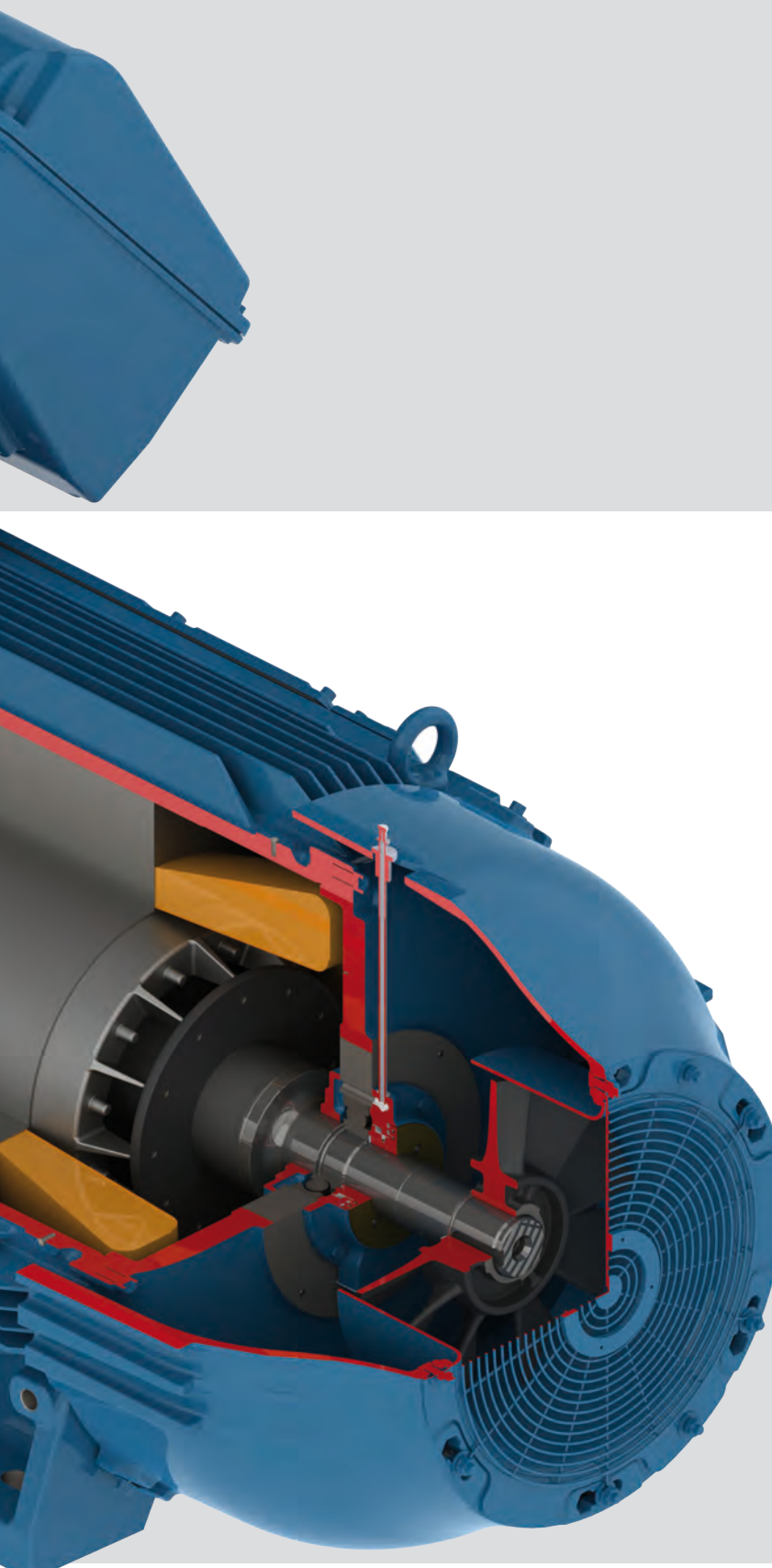

Dedicated W50 lines

The W50 motors also feature a number of definite purpose versions, developed to meet specific industry and application requirements, whilst maintaining the need to provide the best solution for the customer.

W50Xn

With safety being of paramount importance, WEG developed the W50 Non-Sparking (Ex nA) motors line to operate in hazardous areas. This type of protection is applied to electrical equipment which does not cause ignition of an explosive atmosphere under normal operating conditions.

- Suitable for operation in IEC hazardous areas classified as Zone 2, Group II, Temperature class T3
- Compliance with NEC standard requirements regarding hazardous areas, such as Class I, Division 2, Groups B, C and D, Temperature Class T3





W50 IEEE 841

The W50 IEEE841 motors are specially suited for Pulp & Paper mills, Steel mills, Petrochemical Plants and diverse demanding applications requiring severe duty long life motors.

- Internal anticorrosive painting
- Guaranteed foot flatness to within 0.005"
- T-type open drain made of stainless steel 304
- INPRO/SEAL® bearing seal

W50 API 541

The W50 API 541 line was specially developed in accordance with the requirements of the American Petroleum Institute, the World reference in the standardization of equipment for the oil industry.

- Certified for ambient temperatures up to 60°C
- Copper rotor
- Sleeve bearings
- Maximum Is/In of 6.5
- Stainless steel fasteners



WEG Worldwide Operations

ARGENTINA

WEG EQUIPAMIENTOS
ELECTRICOS
San Francisco - Cordoba
Phone: +54 3564 421 484
info-ar@weg.net
www.weg.net/ar

WEG PINTURAS - Pulverlux
Buenos Aires
Phone: +54 11 4299 8000
tintas@weg.net

AUSTRALIA

WEG AUSTRALIA
Victoria
Phone: +61 3 9765 4600
info-au@weg.net
www.weg.net/au

AUSTRIA

WATT DRIVE - WEG Group
Markt Piesting - Viena
Phone: +43 2633 404 0
watt@wattdrive.com
www.wattdrive.com

BELGIUM

WEG BENELUX
Nivelles - Belgium
Phone: +32 67 88 84 20
info-be@weg.net
www.weg.net/be

BRAZIL

WEG EQUIPAMENTOS ELÉTRICOS
Jaraguá do Sul - Santa Catarina
Phone: +55 47 3276-4002
info-br@weg.net
www.weg.net/br

CHILE

WEG CHILE
Santiago
Phone: +56 2 784 8900
info-cl@weg.net
www.weg.net/cl

CHINA

WEG NANTONG
Nantong - Jiangsu
Phone: +86 0513 8598 9333
info-cn@weg.net
www.weg.net/cn

COLOMBIA

WEG COLOMBIA
Bogotá
Phone: +57 1 416 0166
info-co@weg.net
www.weg.net/co

FRANCE

WEG FRANCE
Saint Quentin Fallavier - Lyon
Phone: +33 4 74 99 11 35
info-fr@weg.net
www.weg.net/fr

GERMANY

WEG GERMANY
Kerpen - North Rhine Westphalia
Phone: +49 2237 9291 0
info-de@weg.net
www.weg.net/de

GHANA

ZEST ELECTRIC GHANA
WEG Group
Accra
Phone: +233 30 27 664 90
info@zestghana.com.gh
www.zestghana.com.gh

INDIA

WEG ELECTRIC INDIA
Bangalore - Karnataka
Phone: +91 80 4128 2007
info-in@weg.net
www.weg.net/in

WEG INDUSTRIES INDIA
Hosur - Tamil Nadu
Phone: +91 4344 301 501
info-in@weg.net
www.weg.net/in

ITALY

WEG ITALIA
Cinisello Balsamo - Milano
Phone: +39 02 6129 3535
info-it@weg.net
www.weg.net/it

JAPAN

WEG ELECTRIC MOTORS
JAPAN
Yokohama City - Kanagawa
Phone: +81 45 550 3030
info-jp@weg.net
www.weg.net/jp

MEXICO

WEG MEXICO
Huehuetoca
Phone: +52 55 5321 4231
info-mx@weg.net
www.weg.net/mx

VOLTRAN - WEG Group
Tizayuca - Hidalgo
Phone: +52 77 5350 9354
www.voltran.com.mx

NETHERLANDS

WEG NETHERLANDS
Oldenzaal - Overijssel
Phone: +31 541 571 080
info-nl@weg.net
www.weg.net/nl

PERU

WEG PERU
Lima
Phone: +51 1 472 3204
info-pe@weg.net
www.weg.net/pe

PORTUGAL

WEG EURO
Maia - Porto
Phone: +351 22 9477705
info-pt@weg.net
www.weg.net/pt

RUSSIA and CIS

WEG ELECTRIC CIS
Saint Petersburg
Phone: +7 812 363 2172
info-ru@weg.net
www.weg.net/ru

SOUTH AFRICA

ZEST ELECTRIC MOTORS
WEG Group
Johannesburg
Phone: +27 11 723 6000
info@zest.co.za
www.zest.co.za

SPAIN

WEG IBERIA
Madrid
Phone: +34 91 655 30 08
info-es@weg.net
www.weg.net/es

SINGAPORE

WEG SINGAPORE
Singapore
Phone: +65 68589081
info-sg@weg.net
www.weg.net/sg

SCANDINAVIA

WEG SCANDINAVIA
Kungsbacka - Sweden
Phone: +46 300 73 400
info-se@weg.net
www.weg.net/se

UK

WEG ELECTRIC MOTORS U.K.
Redditch - Worcestershire
Phone: +44 1527 513 800
info-uk@weg.net
www.weg.net/uk

UNITED ARAB EMIRATES

WEG MIDDLE EAST
Dubai
Phone: +971 4 813 0800
info-ae@weg.net
www.weg.net/ae

USA

WEG ELECTRIC
Duluth - Georgia
Phone: +1 678 249 2000
info-us@weg.net
www.weg.net/us

ELECTRIC MACHINERY
WEG Group
Minneapolis - Minnesota
Phone: +1 612 378 8000
www.electricmachinery.com

VENEZUELA

WEG INDUSTRIAS VENEZUELA
Valencia - Carabobo
Phone: +58 241 821 0582
info-ve@weg.net
www.weg.net/ve

For those countries where there is not a WEG own operation, find our local distributor at www.weg.net.



Grupo WEG - Motors Business Unit
Jaraguá do Sul - SC - Brazil
Phone: +55 47 3276 4000
motores@weg.net
www.weg.net

