

Assembly workplace solutions

Contents

Introduction.....	145
TPS Controller	147
TPS Positioning Torque Arms.....	148
Torque arm SML T	149
Torque arm SMS T	150
Carbon arm SMC.....	151
Carbon arm SMC-TT	152
Linear arm SML MK II.....	153
Torque arm SMF.....	154
MicroTorque GHP	155
Torque arm accessories	156
Balancers.....	161

Protect your most valuable resource

Operator health is important. If your operators work with hand-held electric or pneumatic tools, the last thing you want is for their health to suffer. However light the tool, when an operator performs repetitive tasks daily, often with incorrect posture, the tool seems to grow heavier by the hour. Add torque reaction from the tightening process, and the result can be hand-arm-shoulder disorders that may lead to injury and even premature retirement.

Give your operators an extra arm! Atlas Copco torque arms are labour-saving extensions of Atlas Copco hand-held tools that ensure accurate tightening, and raise individual productivity in your plant. Available for torques of up to 1000 Nm, these ingenious constructions are the perfect way to lighten the load when performing repetitive tasks on lines or benches.

EASE THE STRAIN

Atlas Copco torque arms take the strain off your operators, and allow maximum freedom of movement and flexibility. Wide fields of reach mean that the operator has a large working area without stretching.

FAST PAYBACK

Investing in torque arms is not such a major decision. With their benefits in terms of increased productivity and improved employee health, payback time is short.

TO CONSIDER

- However light or low torque, daily use of tools for repetitive tasks can result in hand/arm/shoulder disorders.
- On average a female operator can take 2/3 of the same force as her male colleague.
- Is there enough space for a torque arm at the workplace?
- Finished product quality improvement.
- With the use of a torque arm the arm will absorb all the reaction force from the tool and prevent the tool from spinning around its axis. To ensure highest possible accuracy of the clamp force a torque arm should be used to prevent movement of the tool.



BASIC GUIDELINES FOR TORQUE ARMS

Tools used full days with a torque capacity shown in the table should always be used together with a torque arm in order to prevent work related injuries.

	Straight	Pistol	Angle
Ergonomical optimized*	> 4 Nm	> 7 Nm	> 30 Nm
Conventional tools	> 3 Nm	> 5 Nm	> 20 Nm

* Ergonomically optimized tools is electric tools with two step softstop, turbotight or fast clutch pneumatic tool on a hard joint.

TPS – Tool Positioning System

CONTROL THE SEQUENCE AND THE POSITION

With a TPS controller you are always sure that the operators tighten the joints in the correct sequence and the correct position. The TPS controller works together with the SML/SMS T-series positioning torque arms or the SMC POSI L/LA torque arms and tool controller. The torque arms are equipped with encoders, SMS T-series have 2 angle encoders and SML T-series have 1 linear encoder and 1 angle encoder. The SMC POSI L is equipped with 1 linear encoder to measure the distance the arm travels. SMC POSI LA is equipped with 2 encoders, to measure the distance the arm travel and the angle. The TPS works with digital I/Os for OK or NOK signals to the tool controller to determine the sequence and position of the tool, if the tool is out of position the tool will not start and when the tool is in position it will be able to start. After a correct tightening with OK signal from tool/controller the operator will receive an OK signal from the TPS and is able to start in the next position.

EASY PROGRAMMING

The TPS can use self learning programming, position the tool in the arm over the selected joint and confirm position, go to next joint with the tool/arm and do the same procedure. When all joints are selected validate the job sequence and the TPS is ready for its new job.

50 JOBS – 500 POSITIONS

The TPS can have up to 50 jobs and up to 500 positions (sequences). The TPS can send information to the tool controller to change Pset in the same job which means that it can be different torque settings in the same job and that the same joint can be tightened several times in the same job. When programming the TPS it can also be with different Psets for different jobs so that the operator always has the correct Pset from tool controller when the TPS job is selected.

FAST AND SMOOTH TO START TO INCREASE PRODUCTIVITY

A job can be started by the operator by pressing the start button on the TPS



control and if the TPS is set to Level in job start the operator only needs to push the start button once, when the job is finished with Level setting the same job starts automatically again. Jobs can also be started by a switch button, from tool controller or on timer from previous job.

STAND ALONE SYSTEM

The TPS is a stand alone system that works together with Power Focus, Micro Torque controllers and EBL RE driver. A pneumatic license and air tool package is available to make the TPS work with RE controlled air tools.

OPTIONS

All options are activated by a license code. The license code is ordered separately.

BARCODE READER LICENSE OPTION

Use a barcode reader to start a job and/or identify a job for the TPS to select the correct Pset.

RESULT REPORT FUNCTION OPTION

Save the results to a PC. The results can be saved in two ways, report on job or report on sequence and job.

PNEUMATIC TOOL LICENSE OPTION

The pneumatic tool license also includes the necessary valves and hoses for a correct set up of RE controlled air tools.

TPS CONTROLLER – CONTROL THE SEQUENCE AND THE POSITION

With a TPS controller you are always sure that the operator tightens the joints in the correct sequence and in the correct position.

- Up to 50 jobs and up to 500 positions.
- OK/NOK signal on position.
- The tool will not start when it is out of position.
- Batch count together with OK/NOK on position.
- Works together with Atlas Copco electric tools and RE controlled pneumatic tools.
- Possibility to save and upload set up through a PC.
- Easy and fast set up and programming.
- Error proofing solution.
- ESD approved.



HOW TO ORDER

1. TPS Controller
2. Select positioning torque arm by style (T-series linear or swivel, or SMC telescopic) and torque arm capacity
3. Cable TPS to tool controller
4. Power supply - optional. (Order power cord separately)
5. Select other options if applicable

TPS CONTROLLER

Model	Ordering No.
TPS Controller	8202 9004 10

CONTROLLER ACCESSORY

Model	Ordering No.
I/O Extension TPS	4390 2049 00

POWER SUPPLY/CORD

Model	Ordering No.
Power supply	
24VDC 30W	4222 1728 50
Power cord	
EU	4222 1801 13
US	4222 1802 13
UK	4222 1803 13
India	4222 1804 13
Switzerland	4222 1805 13
Italy	4222 1806 13
Australia	4222 1807 13
China	4222 1809 13

OPTIONS

Model	Ordering No.
Barcode license	4390 2045 00
Pneumatic license	4390 2046 00
Reporting license	4390 2047 00

CABLES

Model	Ordering No.
Cable TPS to controller Power Focus/Tensor	
3 m	4222 1715 03
10 m	4222 1715 10
Cable TPS to controller Power Focus 600	
3 m	4222 1852 03
10 m	4222 1852 10
Cable TPS to EBL RE driver	
1.5 m	4222 1733 01
3 m	4222 1733 03
Cable TPS to controller G4	
1.5 m	4222 1734 01
3 m	4222 1734 03
Cable TPS to controller MTF400	
1.5 m	4222 1735 01
3 m	4222 1735 03
TPS Open End cable	
3 m	4222 1743 03
10 m	4222 1743 10

TPS Positioning Torque Arms

SMC POSI L

SMC carbon arms with 1 encoder to measure the distance the arm travels. With this arm and encoder it is possible to verify the position due to the distance the arm travels. The encoder is mounted inside the arm to safe guard that nothing can interfere with the distance measurements. The SMC POSI L arm can work in both horizontal and vertical position and thus be roof or wall mounted. The accuracy of the encoder is 0.32 mm and the arm together with a TPS controller control the sequence and position.

- Carbon arm with position control up to 200 Nm.
- Encoder measures the distance the arm travels.
- Verify position due to distance.
- Can be mounted both in horizontal and vertical position for maximum flexibility.
- Accuracy of encoder 0.32 mm.
- Control the sequence and position together with TPS controller.

SMC POSI LA

SMC carbon arms with 2 encoders to measure the length the arm travels and the angle of the arm to determine the position of the arm/tool. With this SMC carbon arm it is possible to verify the position due to the length the arm travels together with an encoder that measures the angle of the arm. The length encoder is mounted inside the arm to safe guard that nothing can interfere with the length measurement and the angle encoder is mounted at the top of the arm. The SMC POSI LA can work in both horizontal and vertical position and thus be roof or wall mounted. The accuracy of the encoders is 0.32 mm and the arm together with a TPS controller will control the sequence and position.

- Carbon arm with 2 encoders to control position.
- Encoders measure the arm travel length and the angle of the arm to determine the position.
- Can be mounted both in horizontal and vertical position for maximum flexibility.
- Accuracy of encoder is 0.32 mm.
- Control the sequence and position together with the TPS controller.
- Arms available up to 200 Nm.

SML/SMS T-SERIES POSITIONING ARMS

The Atlas Copco T-series of arms are built to handle the most demanding industrial situation when you need to control the sequence and the position. The T-series arms are equipped with two encoders, SMS T-series have 2 angle encoders to determine the position and



SML T-series have 1 linear encoder and 1 angle encoder to determine the position. The arms are delivered with balancer, encoders and encoder cables ready to be plugged into the TPS controller.

- Control the sequence and position together with TPS controller.
- Excellent working area for work bench assembly stations.
- Available up to 100 Nm.

SMC CARBON ARMS WITH 1 ENCODER

Model	Ordering No.
SMC 12 1150 POSI L	4390 1510 77
SMC 12 1600 POSI L	4390 1511 87
SMC 12 2100 POSI L	4390 1512 87
SMC 25 1150 POSI L	4390 1514 77
SMC 25 1600 POSI L	4390 1515 87
SMC 25 2100 POSI L	4390 1516 87
SMC 25 2600 POSI L	4390 1517 87
SMC 50 1600 POSI L	4390 1518 77
SMC 50 2100 POSI L	4390 1519 87
SMC 50 2600 POSI L	4390 1520 87
SMC 100 1600 POSI L	4390 1522 87
SMC 100 2100 POSI L	4390 1523 77
SMC 100 2600 POSI L	4390 1524 87
SMC 200 1600 POSI L	4390 1526 87
SMC 200 2100 POSI L	4390 1527 87
SMC 200 2600 POSI L	4390 1528 87

SML / SMS T ARMS WITH 2 ENCODERS

Model	Ordering No.
SML T-5 Position	4390 2030 00
SML T-12 Position	4390 2031 00
SML T-25 Position	4390 2032 00
SML T-50 Position	4390 2034 00
SML T-100 Position	4390 2035 00
SMS T-5 Position	4390 2036 00
SMS T-12 Position	4390 2037 00
SMS T-25 Position	4390 2038 00
SMS T-50 Position	4390 2039 00
SMS T-100 Position	4390 2040 00

SMC CARBON ARMS WITH 2 ENCODERS

Model	Ordering No.
SMC 12 1150 POSI LA	4390 1510 79
SMC 12 1600 POSI LA	4390 1511 79
SMC 12 2100 POSI LA	4390 1512 79
SMC 25 1150 POSI LA	4390 1514 79
SMC 25 1600 POSI LA	4390 1515 79
SMC 25 2100 POSI LA	4390 1516 79
SMC 25 2600 POSI LA	4390 1517 79
SMC 50 1600 POSI LA	4390 1518 79
SMC 50 2100 POSI LA	4390 1519 79
SMC 50 2600 POSI LA	4390 1520 79
SMC 100 1600 POSI LA	4390 1522 79
SMC 100 2100 POSI LA	4390 1523 79
SMC 100 2600 POSI LA	4390 1524 79
SMC 200 1600 POSI LA	4390 1526 79
SMC 200 2100 POSI LA	4390 1527 79
SMC 200 2600 POSI LA	4390 1528 79

NOTE: Tool holder needs to be ordered separately. SML/SMS T-series are equipped with balancer.

Choose the appropriate balancer for SMC arms depending on tool weight and order the balancer kit for easy and fast assembly if the arm is roof mounted.

SML T – SERIES TORQUE ARMS

The Atlas Copco linear arms are built to handle the most demanding industrial situations. The robust design offers unmatched user friendliness. The linear arms are equipped with ball bearings for smooth operation, and an adjustable plate for maximum adjustment of minimum and maximum working area. The linear arms have balancer included that will absorb the weight of the arm and tool combination to reduce the weight for the operator. The arms minimize the reaction force of the tool to prevent hand-arm-shoulder disorders. With minimized reaction force of the tool, finished product quality is also higher since there is no movement of the tool and all torque is absorbed in the joint.

- Robust construction for long life and no force transferred to operator.
- Balancer included to remove the tool and arm weight from the operator.
- Available from 5 Nm up to 100 Nm.
- Minimizes reaction force to prevent hand-arm-shoulder disorders.
- Improves finished product quality with all torque absorbed in the joint and no movement of tool.



Model	Max tool weight		Max torque		Min width without tool holder mm	A Max reach without tool holder mm	B		C Height mm	Tool holder interface type	Ordering No.
	kg	lb	Nm	ft lb			Horizontal stroke mm	Vertical stroke mm			
SML T-5	0.8	1.7	5	3.7	158	530	205	310	732	A	4390 2000 00
SML T-12	1.5	3.3	12	8.8	198	648	255	465	888	A	4390 2001 00
SML T-25	2.2	4.8	25	18.4	167	732	290	615	1100	A	4390 2002 00
SML T-50	5	11	50	36.9	267	887	355	515	1116	B	4390 2004 00
SML T-100	6	13.2	100	73.8	255	914	395	515	1116	B	4390 2005 00

Tool holder is ordered separately.

Dimensions

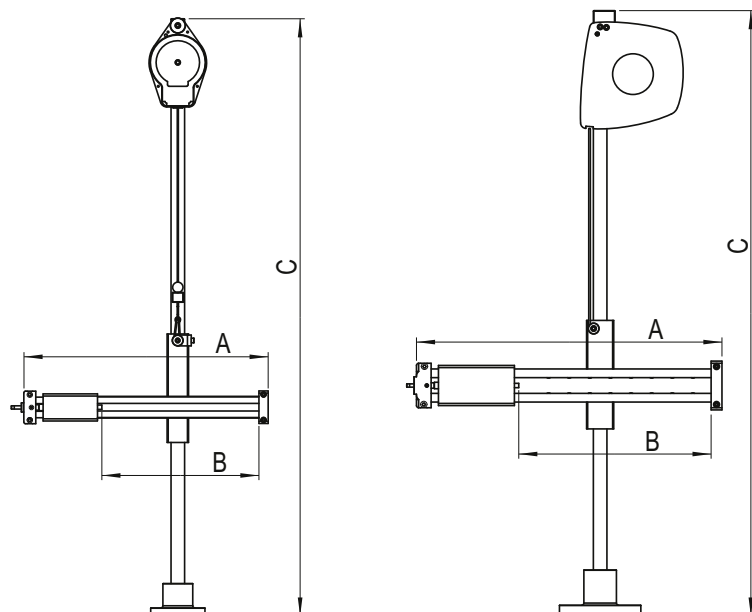

SMST – SERIES TORQUE ARMS

The Atlas Copco linear arms are built to handle the most demanding industrial situations. The robust design offers unmatched user friendliness and, due to the swivel function, a wide working area is covered with the SMS T-series. The swivel arms are equipped with ball bearings for smooth operation, and an adjustable plate for maximum adjustment of minimum and maximum working area. The swivel arms have a balancer included that will absorb the weight of the arm and tool combination to reduce the weight for the operator. The arms minimize reaction force of the tool to prevent hand-arm-shoulder disorders. With minimized reaction force of the tool, finished product quality is also higher since there is no movement of the tool and all torque is absorbed in the joint.

- Robust construction for long life and no force transferred to operator.
- Balancer included to remove the tool and arm weight from the operator.
- Available from 5 Nm up to 100 Nm.
- Minimizes reaction force to prevent hand-arm-shoulder disorders.
- Improves finished product quality with all torque absorbed in the joint and no movement of the tool.



Model	Max tool weight		Max torque		D Swivel rods width without tool holder mm	B+D Max reach without tool holder mm	C Vertical stroke mm	A Height mm	B Width mm	Tool holder interface type	Ordering No.
	kg	lb	Nm	ft lb							
SMS T-5	0.8	1.7	5	3.7	292	582	270	732	248	A	4390 2006 00
SMS T-12	1.5	3.3	12	8.8	342	682	425	888	298	A	4390 2007 00
SMS T-25	2.5	5.5	25	18.4	392	732	580	1132	296	A	4390 2008 00
SMS T-50	5	11	50	36.9	437	825	520	1147	336	B	4390 2009 00
SMS T-100	6	13.2	100	73.8	487	930	500	1147	391	B	4390 2010 00

Tool holder is ordered separately.

Dimensions

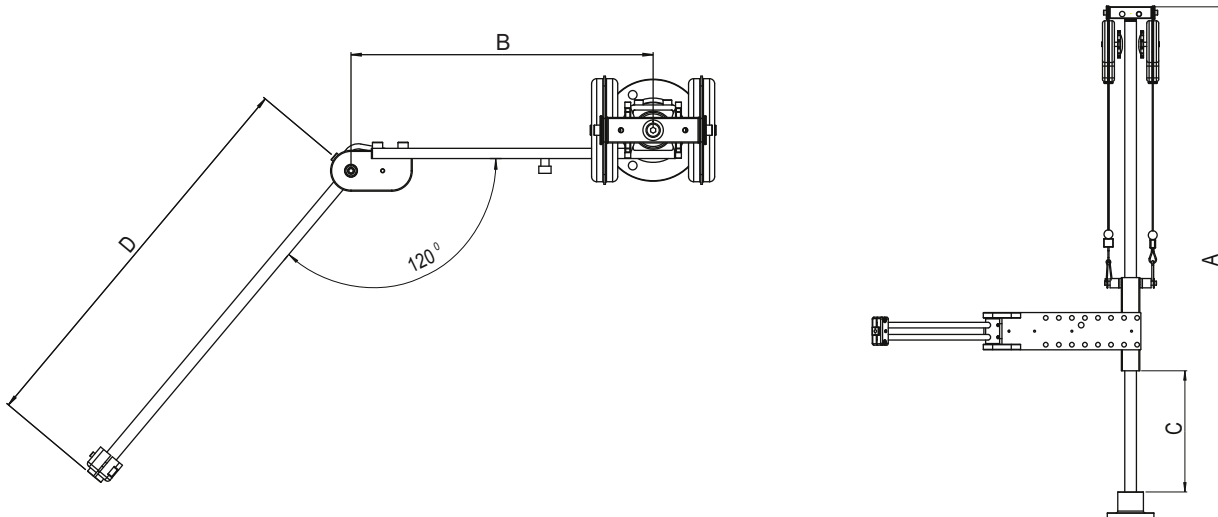

SMC – CARBON ARMS

The Atlas Copco carbon arms have a telescopic design for maximum flexibility in the workplace. The carbon arms are light weight with smooth movements to reduce the operator force to use the arms. Together with a balancer the carbon arms can either retract up or be used in a weightless position to improve operator comfort. The carbon arms minimize reaction force to prevent hand-arm-shoulder disorders. With minimized reaction force of the tool you will also improve finished product quality because there is no movement of the tool and all torque is absorbed in the joint.

- Telescopic design for maximum flexibility in the workplace.
- Light weight and smooth movements for operator comfort.
- Easy to use together with balancer to create weightless solution to improve ergonomics.



- Minimizes reaction force to prevent hand-arm-shoulder disorders.
- Minimizes pinching and can replace reaction bars.
- Improve finished product quality with all torque absorbed in the joint and no movement of the tool.

Model	Max torque		Min length mm	Max length mm	A Max tool holder swivel angle [deg]	Weight		Tool holder interface type	Ordering No.
	Nm	ft lb				kg	lb		
SMC 12 1150	12	8.9	516	1128	60	0.37	0.816	A	4390 1510 85
SMC 12 1600	12	8.9	666	1578	60	0.42	0.926	A	4390 1511 85
SMC 12 2100	12	8.9	835	2083	60	0.48	1.06	A	4390 1512 85
SMC 25 1150	25	18.4	524	1124	50	0.51	1.12	A	4390 1514 85
SMC 25 1600	25	18.4	674	1574	50	0.61	1.34	A	4390 1515 85
SMC 25 2100	25	18.4	841	2075	50	0.68	1.5	A	4390 1516 85
SMC 25 2600	25	18.4	1007	2573	50	0.77	1.7	A	4390 1517 85
SMC 50 1600	50	36.9	712	1624	40	0.95	2.09	B	4390 1518 85
SMC 50 2100	50	36.9	878	2125	40	1.05	2.31	B	4390 1519 85
SMC 50 2600	50	36.9	1045	2626	40	1.15	2.54	B	4390 1520 85
SMC 100 1600	100	73.8	722	1628	30	1.28	2.82	B	4390 1522 85
SMC 100 2100	100	73.8	889	2129	30	1.41	3.11	B	4390 1523 85
SMC 100 2600	100	73.8	1056	2630	30	1.53	3.37	B	4390 1524 85
SMC 200 1600	200	148	726	1628	20	1.98	4.37	-	4390 1526 85
SMC 200 2100	200	148	893	2129	20	2.18	4.81	-	4390 1527 85
SMC 200 2600	200	148	1060	2630	20	2.39	5.27	-	4390 1528 85
SMC 300 1600	300	221	744	1631	20	2.40	5.29	-	4390 1530 85
SMC 300 2100	300	221	911	2132	20	2.60	5.73	-	4390 1531 85
SMC 300 2600	300	221	1078	2633	20	2.81	6.20	-	4390 1532 85

Tool holder is ordered separately. Choose the appropriate balancer depending on tool weight. Order the balancer kit for easy and fast assembly.
NOTE: A: 17 mm square interface, B: 32 mm square interface. For SMC 200 the tool holders connect directly to the clevis of the arm.

Dimensions

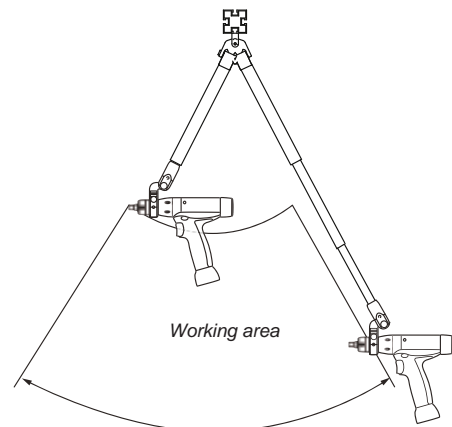
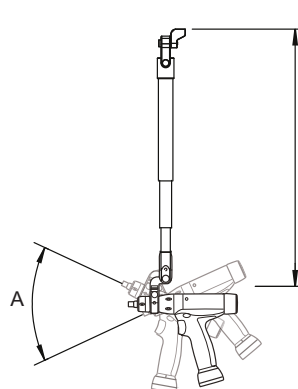

SMC-TT – CARBON ARMS

The SMC-TT torque arm range from Atlas Copco consists of three models varying from 10 to 25 Nm. The SMC-TT torque arms are designed to be used in combination with handheld straight and angle tools, including both electric and pneumatic. They are suited to be utilized for various rail and roof-mounted applications in all sorts of assembly environments. The product range has a modular setup with several available combinations and accessories to provide the most efficient and ergonomic workstation. The availability of a rigid top fixation allows the SMC-TT arm to be fastened to a roof attachment. The 10 Nm torque arm is available in one length version and the 25 Nm models are available in two length variants to achieve better reach.

- Easy to position and handle torque arms that allow for smooth movements to achieve operator comfort.
- Telescopic design for maximum flexibility with an extensive working range.
- Easy to use together with balancer to create weightless solution leading to improved operator ergonomics.
- Minimized strain to prevent wrist/arm/shoulder injuries due to repetitive use.
- Improved finished product quality with all torque absorbed in the joint and no movement of the tool.



Model	Max torque		Min length mm	Max length mm	A	B	C	Weight		Tool holder interface type	Ordering No.
	Nm	ft lb			Max tool holder swivel angle [deg]	Max tool holder swivel angle [deg]	Max tool holder swivel angle [deg]	kg	lb		
SMC-TT-10-850	10	7.4	713	1013	60	8	24	1.4	3.1	A	4390 1510 29
SMC-TT-25-1150	25	18.4	831	1131	60	8	24	3.5	7.8	A	4390 1510 31
SMC-TT-25-1150	25	18.4	1131	1731	60	8	24	4.0	8.7	A	4390 1510 32

Dimensions

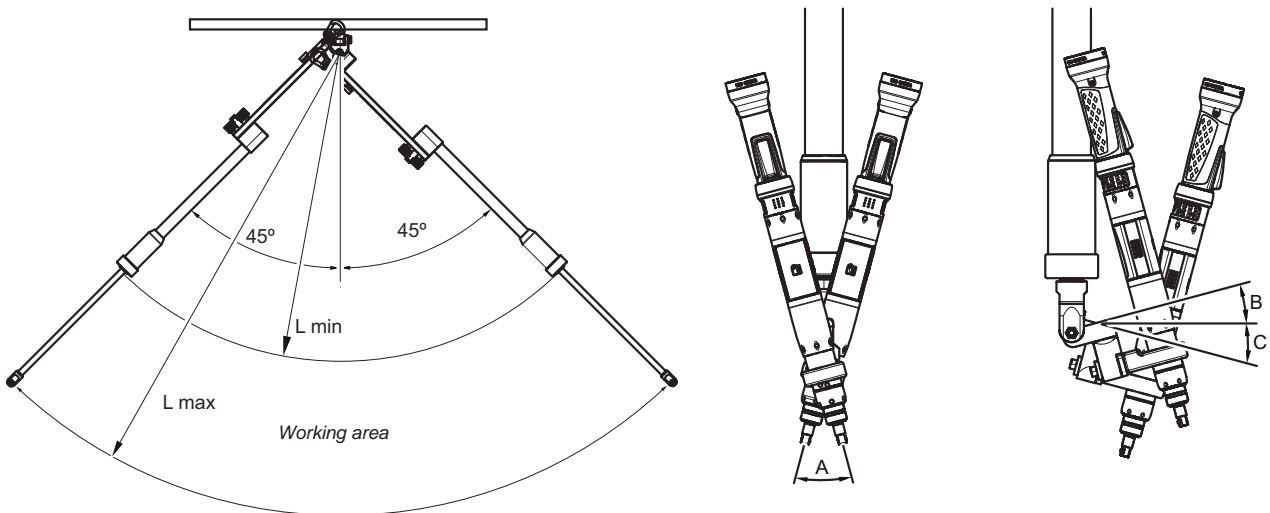

TORQUE ARM SML MK II

By mounting your assembly tool on a SML MK II torque arm you will immediately increase the productivity and reduce muscular stress from your operators. All arms are delivered with integrated balancer, 3-axis movement and the Atlas Copco interface for tool holders. The 3-axis movement allows the operator to ease the arm effortlessly around the workstation.

- 3-axis movement for maximum flexibility.
- Strong and durable desing.
- Integrated balancer to support tool and arm weight.
- High torque capacity, up to 1000 Nm.
- Same tool holder interface as SML T / SMS T / SMC for arms up to 150 Nm.



Model	Max tool weight		Max torque		D Horizontal stroke mm	C Vertical stroke mm	A Height mm	Tool holder interface type	Ordering No.
	kg	lb	Nm	ft lb					
SML 10 MK II	1	2.2	10	7.4	240	220	680	A	8202 9003 20
SML 40 MK II	2.3	5.1	40	29.5	280	290	834	B	8202 9003 21
SML 80 MK II	5.2	11.5	80	59	320	360	964	B	8202 9003 22
SML 150 MK II	7	15.4	150	110.7	360	430	1049	C	8202 9003 23
SML 300 MK II	14	30.9	300	221.4	400	500	1231	C	8202 9003 24
SML 500 MK II	10	22	500	369	440	570	1361	C	8202 9003 25
SML 1000 MK II	11.3	24.9	1000	738	480	640	1571	C	8202 9003 26

Tool holder is ordered separately.

Dimensions

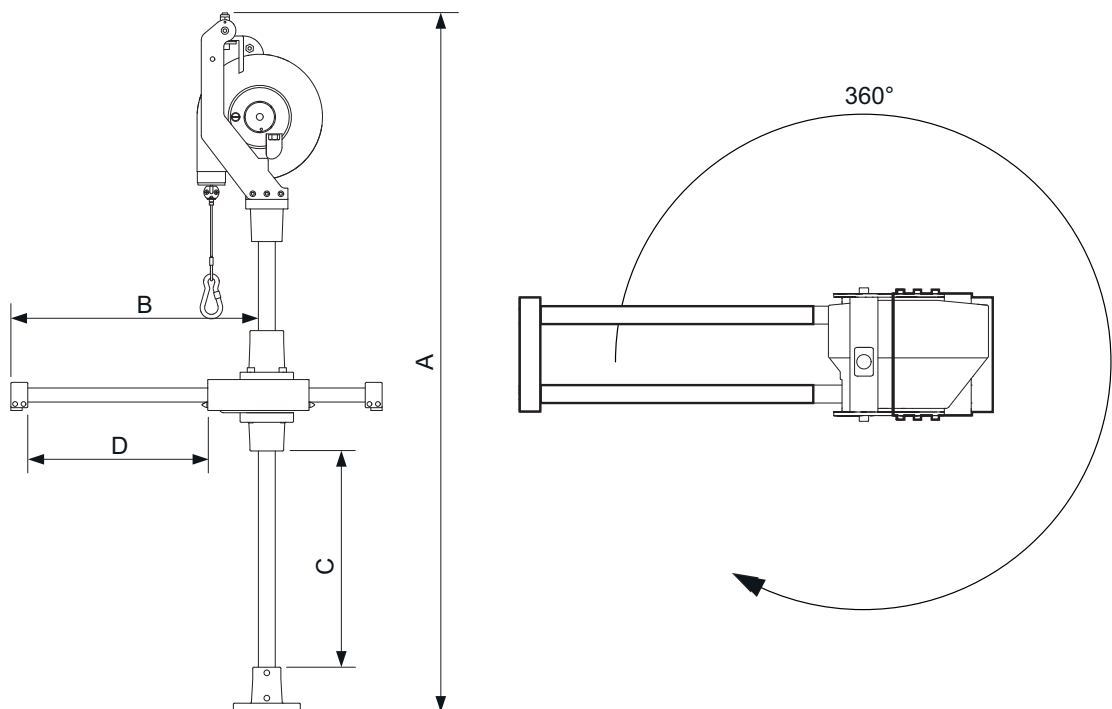

TORQUE ARM SMF

The SMF-25 torque arms are labor-saving extensions of the Atlas Copco hand-held tools. They are made of aluminum and are suitable for straight and pistol assembly tools up to 25 Nm. The parallel torque arm has a foldable and space-saving design that eliminates the weight and torque of the tool, thus improving operator ergonomics, providing accurate tightening and contributing to increased productivity.

The SMF-25 arm range has a bench stand with a working area of 710 mm and 870 mm allowing tool setups weighing up to 2 kg (4.4 lb). These arms can also be used with a wall mount, therefore making them suitable for either flat wall surfaces or structural framing systems in assembly environments. All related accessories and tool holders need to be ordered separately.

- Robust construction that diminishes the transferred force to operator and extends product longevity.
- Springs included to eliminate tool and arm weight from the operator.
- Reaction force minimized to prevent hand/arm/shoulder disorders.
- Improved product quality due to torque absorption in the joint and no movement of the tool.



Model	Max tool weight		Max torque		A Max reach without tool holder	B Horizontal stroke	C Vertical stroke	Tool holder interface type	Ordering No.
	kg	lb	Nm	ft lb	mm	mm	mm		
SMF-25-710	2.0	4.4	25	18.4	710	300	300	A	4390 2083 00
SMF-25-870	2.0	4.4	25	18.4	870	400	400	A	4390 2083 30

Dimensions

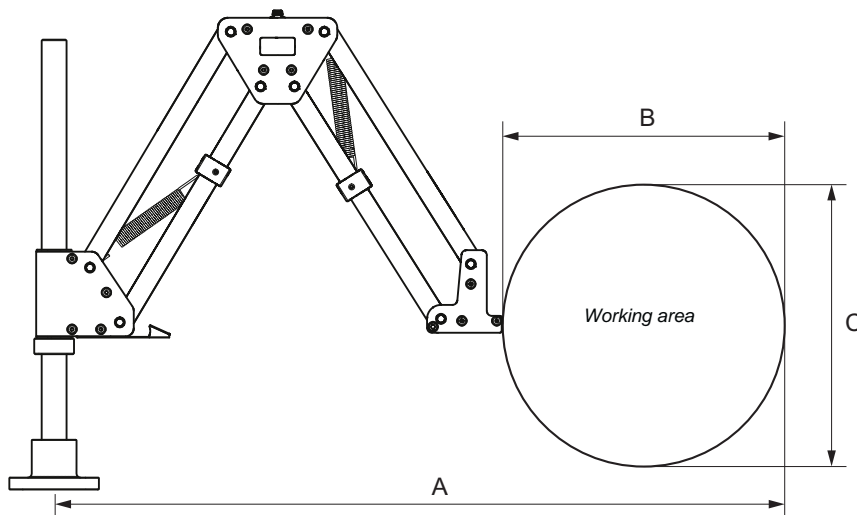

GHP – TORQUE ARM FOR MICROTORQUE RANGE

Atlas Copco GHP torque arm is an excellent means of assistance when using hand-held or fixtured straight microtorque screwdrivers.

Torque arm GHP Mini is recommended with screwdrivers below 100 Ncm, and GHP Small below 200 Ncm.

The GHP torque arms are exceptionally easy to position and handle. The design is intended for low torque applications and work tasks over a long period of time. Comes with appropriate balancing system to support the weight of the tool.



Model	Stroke mm	alfa	Ordering No.
GHP Mini	200	270°	8432 0830 02
GHP Small	400	270°	8432 0830 03
GHP Large	730	270°	8432 0830 04

Tool holder is ordered separately.

Dimensions

Model	Working range, mm	
	A	B
GHP Mini	280	150
GHP Small	460	250
GHP Large	500	250

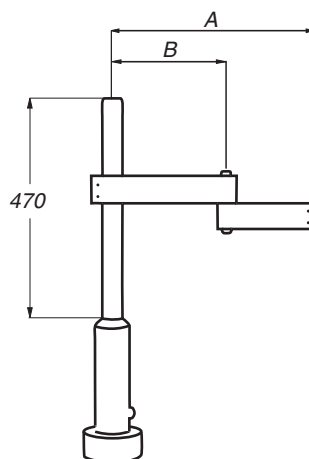

GHP Mini

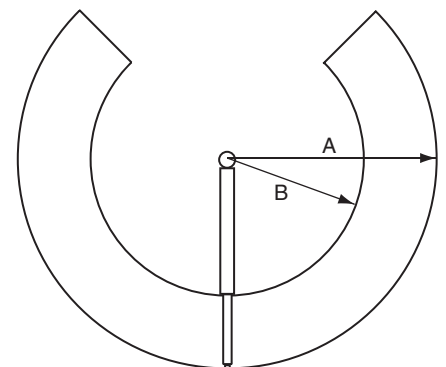

GHP Small/GHP Large

Torque Arm Accessories

Optional Accessories

TOOL HOLDER GUIDE

Atlas Copco tool holders are designed to optimize your workplace solution. Depending on tool, torque arm and application you can choose from a wide range of tool holders; universal holder, specific diameter holders, spline holders, mounting plates with spine or hole, pistol tool holders or angle tool holders. A tool specific tool holder is always better than a universal holder.



Universal tool holder



Tool holder, diameter



Mounting plate



Tool holder, Spline

HOW TO BUILD YOUR WORKPLACE SOLUTION

- 1) Tool
- 2) Torque arm
 - Torque range
 - Work area
 - Tool weight
- 3) Tool holder
 - Arm - Tool holder interface type (or mounting on arm clevis, as for SMC angle tool holders)
 - Tool interface: eg. Spline, Diameter or Angle
- 4) Accessories
- 5) For SMC - Balancer

TOOL HOLDERS FOR TORQUE ARMS WITH TOOL HOLDER INTERFACE TYPE A SMC 12/25 AND SMS/L T 5/12/25 AND SML MK II 10

Model	Tool dia. mm	Spline type	Arm interface type	Description	Ordering No.
Universal holder	26 - 49	-	A	Max tool torque 25 Nm	4390 1510 86
Holder, Spline 1	-	1	A		4390 1513 07
Holder, diameter 30.5	30 - 30.5	-	A		4390 1513 80
Holder, diameter 34	33.5 - 34	-	A		4390 1513 81
Holder diameter 36.5	36 - 36.5	-	A		4390 1513 82
Holder diameter 38	37.5 - 38	-	A		4390 1513 83
Holder diameter 44	43.5 - 44	-	A		4390 1513 84
Holder diameter 46	45.5 - 46	-	A	To be used with adapter	4390 1513 85
Special adapters to be used with dia 46 mm tool holder				LUM10 PR	4390 1734 09
				ELI	4390 1734 08
				LUM21 PR-P	4390 1735 44
				LUM12 SR	4390 1735 52
				LUM12 PR	4390 1735 53
				LUM22 PR	4390 1735 54
Holder diameter 56	55.5-56	-	A	To be used with adapter	4390 1513 86
Special adapters to be used with dia 56 mm tool holder				LUM21 SR	4390 1735 45
				LUM22 SR	4390 1735 51
Mounting plate, Spline 1	-	1	A		4390 2020 00
Mounting plate, Spline 2	-	2	A		4390 2020 01
Mounting plate, hole 24	24	-	A		4390 2020 02
Mounting plate, hole 26	26	-	A		4390 2020 03
Mounting plate, hole 28	28	-	A		4390 2020 04
Mounting plate, blank	-	-	A		4390 2020 05

TOOL HOLDERS FOR TORQUE ARMS WITH TOOL HOLDER INTERFACE TYPE B, SMC 50/100 AND SMS/L T 50/100 AND SML MK II 40/80

Model	Tool dia. mm	Spline type	Arm interface type	Description	Ordering No.
Universal holder	30 - 50	-	B	Max tool torque 50 Nm	4390 2064 80
Holder, Spline 1	-	1	B		4390 1513 08
Holder, Spline 2	-	2	B		4390 1513 09
Holder, Spline 3	-	3	B		4390 1513 10
Holder, hole 24	24	-	B		4390 1518 22
Mounting plate, Spline 1	-	1	B		4390 2021 00
Mounting plate, Spline 2	-	2	B		4390 2021 01
Mounting plate, Spline 3	-	3	B		4390 2021 02
Mounting plate, hole 24	24	-	B		4390 2021 03
Mounting plate, hole 26	26	-	B		4390 2021 04
Mounting plate, hole 28	28	-	B		4390 2021 05
Mounting plate, blank	-	-	B		4390 2021 06

Optional Accessories

SWIVELING TOOL HOLDERS FOR SMC CARBON ARMS

Model		Tool dia. mm	Ordering No.
For SMC 50			
Swiveling tool holder	50 – A	39	4390 2081 86
	50 – B	43	4390 2081 74
	50 – C	45	4390 2081 75
	50 – D	36.5	4390 2081 76
For SMC 100			
Swiveling tool holder	100 – A	39	4390 2081 56
	100 – B	43	4390 2081 57
	100 – C	45	4390 2081 58
	100 – E	40	4390 2081 55
For SMC 200			
Swiveling tool holder	200 – A	39	4390 2081 85
	200 – B	43	4390 2081 77
	200 – C	45	4390 2081 78



Tool holder, Swiveling

MOUNTING PLATES FOR SML MK II 150/300/500/1000 TORQUE ARMS, TOOL HOLDER INTERFACE TYPE C

Model	Tool dia. mm	Spline type	Arm interface type	Description	Ordering No.
Mounting plate, Spline 1	-	1	C		4390 1760 00
Mounting plate, Spline 2	-	2	C		4390 1761 00
Mounting plate, Spline 3	-	3	C		4390 1762 00
Mounting plate, Spline 4	-	4	C		4390 1763 00
Mounting plate, Spline 5	-	5	C		4390 1764 00
Mounting plate, Spline 6	-	6	C		4390 1765 00
Mounting plate, Spline 7	-	7	C		4390 1766 00
Mounting plate, QMX/ETX50	-	-	C		4390 1782 00
Mounting plate, QMX/ETX62	-	-	C		4390 1783 00
Mounting plate, QMX90/ETX90	-	-	C		4390 1785 00
Extension mounting plate	-	-	C		4390 1768 00



Mounting plate



Extension mounting plate

PISTOL TOOL HOLDERS FOR SMC CARBON ARMS

Model	Tool dia. mm	Spline type	Arm interface type	Description	Ordering No.
Pistol holder, hole 24	24	-	-	For SMC 50	4390 1518 18
Pistol holder, Spline 2	-	2	-	For SMC 100	4390 1522 18
Pistol holder, Spline 2	-	2	-	For SMC 200	4390 1526 18
Pistol holder, Spline 3	-	3	-	For SMC 200	4390 1513 11

Tool holder connects directly to the clevis of the arm.



Pistol holder

ANGLE TOOL HOLDERS FOR SMC CARBON ARMS, SMC 50

Model	Description	Ordering No.
Angle tool holder for	LTV38-R50-13, LTV38-R42-13	4390 2062 80
	LTV38-R50-HAD, LTV38-R42-HAD	4390 2062 81
	LTV38-R50-10, LTV38-R42-10	4390 2062 82
	LTV39-2 R30-10, LTV39-2 R37-10, LTV39-2 R48-10	4390 2062 83
	ETV ST61-40-10, ETV ST61-40-HAD,	4390 2062 84
	ETV STB62-40-10, ETV STB62-50-10	4390 2062 85
	ETV STB32-30-10, ETV ST61-30-10,	
	ETV STB62-30-10	
	LTV39-2 R48-13	4390 2062 86
	LTV29-2 R30-10	4390 2062 87

Tool holder connects directly to the clevis of the arm.



Angle tool holder

Torque Arm Accessories

Optional Accessories



Angle tool holder

ANGLE TOOL HOLDERS FOR SMC CARBON ARMS, SMC 100

Model	Description	Ordering No.
Angle tool holder	ETV ST81-100-13, ETV ST61-100-13, ETV STB62-100-13	4390 2061 80
	ETV STB62-70-13, ETV ST81-70-13-L150, ETV ST81-70-13, ETV ST61-70-13, ETV ST81-90-HAD, ETV ST61-90-HAD	4390 2061 82
	LTV39-2 R70-13, LTV39-2 R56-13	4390 2061 83
	LTV39-2 R85-13	4390 2061 84
	LTV38-R85-13	4390 2061 85
	LTV38 R85-HAD	4390 2061 86
	ETV ST81-50-10, ETV ST61-50-HAD, ETV ST61-50-10, LTV39-2 R56-10	4390 2061 87
	ETV ST101-100-HAD, ETV ST101-100-13, ETV ST101-100-INTEL	4390 2061 88
	LTV38 R70-13	4390 2061 89
	LTV38 R57-13	4390 2061 90

Tool holder connects directly to the clevis of the arm.

ANGLE TOOL HOLDERS FOR SMC CARBON ARMS, SMC 200

Model	Description	Ordering No.
Angle tool holder	ETV ST61-200, ETV ST81-200	4390 1513 87
	ETV ST101-180-13 / 13-F / 13-M / 13-M-F, ETV ST101-180-B13 / B13-F,	4390 2060 80
	ETV ST61-150-13 / B13 / 13-ATEX, ETV ST61-180-13 / B13 / 13-ATEX, ETV ST81-150-13 / B13, ETV ST81-180-13 / B13	4390 2060 81
	LTV48 R120-L13 / R150-L13 / R200-L13	4390 2060 84
	LTV69 R180-13, LTV69 N180-13	4390 2060 85
	LTV48 R120-HAD / R150-HAD / R200-HAD	4390 2060 86
	LTV48 R120-FS / R150-FS / R200-FS	
	ETV ST61-150-FS / 180-FS	4390 2060 87
	ETV ST61-120-HAD / 150-HAD / 180-HAD	
	ETV ST81-120-HAD / 150-HAD / 180-HAD	
	ETV ST81-150-FS / 180-FS	
	ETV ST101-180-FS / FS-F, ETV ST101-180-Intel / Intel-F	4390 2060 88
	ETV ST101-180-HAD / HAD-F	

Tool holder connects directly to the clevis of the arm.

TOOL HOLDERS FOR SMC CARBON ARMS, SMC 300

Model	Description	Ordering No.
Angle tool holder	ETV ST101-270	4390 2081 50
Pistol tool holder	ETP ST101-300-20-F (Tensor Revo)	4390 2081 51



Bench stand

OPTIONAL ACCESSORIES FOR SMC CARBON ARMS

Model	Description	Ordering No.
Bench stand	Bench stand with height 753 mm. Holder must be ordered separately	4390 1728 00
Holder for bench stand	Stand attachment 12-25 Nm	4390 1510 88
	Stand attachment 50-100 Nm	4390 1518 88
	SMC 200 should not be used with table stand	
Balancer kit	SMC Balancer adaptor kit for RIL 1C-5C and WP10	4390 2050 00
	SMC Balancer adaptor kit for WP05	4390 2078 80



Holder for bench stand

Optional Accessories

OPTIONAL ACCESSORIES FOR SMC-TT CARBON ARMS

Model	Description	Ordering No.
For SMC-TT-10		
Straight tool adapter – A	To attach tool holder for straight tools	4390 2022 04
Balancer adapter – A	To attach balancer RIL4-5C	4390 2022 01
Gravity center adapter – A	To adjust gravity center	4390 2022 02
Rigid top fixation – A		4390 2022 03
For SMC-TT-25		
Straight tool adapter – B	To attach tool holder for straight tools	4390 2022 08
Balancer adapter – B	To attach balancer RIL4-5C	4390 2022 05
Gravity center adapter – B	To adjust gravity center	4390 2022 06
Rigid top fixation – B		4390 2022 07

OPTIONAL ACCESSORIES FOR SMF ARMS

Model	Description	Ordering No.
Wall mount	For attachment on wall or rail	4390 2081 10

Installation Proposals for SML



OPTIONAL ACCESSORIES FOR SML/SMS T-SERIES, SML MK II AND SMF

Model	Description	Ordering No.
Pistol tool adapter – one axis	One axis swiveling adapter for tools up to 25 Nm	4390 2082 10
Pistol tool adapter – two axes	Two axes swiveling adapter for tools up to 25 Nm	4390 2082 30
Horizontal adapter (handle mount)		4390 1770 00
Vertical adapter (handle mount)		4390 1769 00
Start handle	(electric, 1 signal)	4390 1772 00
	(electric, 2 signal)	4390 1773 00
	(pneumatic)	4390 1771 00
Heavy duty start handles	(electric, 1 signal)	4390 1772 01
	(electric, 2 signal)	4390 1773 01
	(pneumatic)	4390 1771 01
Heavy duty handgrip (dead)		4390 1786 01
Handgrip (dead handle)		4390 1786 00
Remote start cable	3 m	4390 1774 00
	5 m	4390 1775 00
	10 m	4390 1776 00
Extension remote start cable	10 m	4390 1778 00
Y– piece connector (for 2 x electric handles)		4390 1777 00



Horizontal adapter

Start handle

NOTE: – For forward and reverse tool operation, a 2 signal handle is required (electric tools only).

Torque Arm Accessories

Optional Accessories for GHP MicroTorque

Description	Ordering No.
Adapter	
Adapter between GHP Mini and ETF 5, 10, 20	8432 0830 70
Adapter between GHP Mini and ETD M 03/05/10A	8432 0831 81
Adapter between GHP Small and ETF 50-200	8432 0830 72
Adapter between GHP Small and ETD M-40-250 L	8432 0830 73
Adapter between GHP Large and ETF 400, 500, 800	8432 0830 74
Universal adapter for GHP Small (LUM, EBL, DL, SL)	8432 0831 80
Handle	
Handle between GHP Mini and ETF 05, 10, 20	8432 0830 90
Handle between GHP Small and ETF 50, 100, 200	8432 0830 53
Handle between GHP Large and ETF 400, 500, 800	8432 0830 54
Swivling tool holder	
GHP Small and ETD M08-27 ABL V2	8432 0830 61
GHP Small and ETD M50-250 ABL V2	8432 0830 62



Swivling tool holder

TOOL HOLSTER FOR PISTOL GRIP AND STRAIGHT TOOLS

Model	Ordering No.
Tool holster small, max tool width 45 mm	4220 3584 82
Tool holster large , max tool width 98 mm	4220 3584 84
Holster assembly	4220 3584 80
Tool holster BCP	4220 4335 80



Tool holster small

MODULAR TOOL HOLDER FOR PISTOL TOOLS, ANGLE TOOLS AND GRINDERS

Model	Included parts	Ordering No.
Modular tool holder	A	4220 3584 83
Modular tool holder, rail kit	2 x A, B	4220 3584 84
Modular tool holder, stand kit	2 x A, B, C	4220 3584 85



Tool holster large

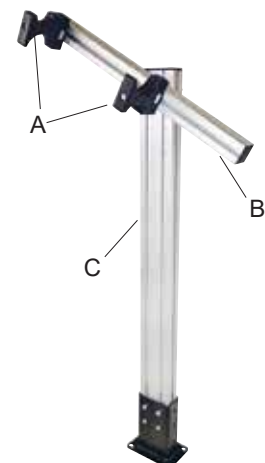

Modular tool holder

COLIBRI – COL

Balancers in the unique COL range hold the load and keep it weightless throughout the entire cable length.

PRODUCTIVITY

COL balancers always hold the tool in the correct position

ERGONOMIC

COL balancers reduce the stress level in the operator's muscles.

SAFETY

The load is not pulled back when released and the surroundings are protected from accidental hoisting of the load.

The cable locks in the event of spring failure (downward braking power).

In all models the braking function can be activated upwards by using the “bow and arrow” principle if you need to slacken the cable to change the tool.



Model	Capacity range		Cable length m	Weight		Dimensions			Ordering No.
	kg	lb		kg	lb	A mm	B mm	C mm	
COL 1 01	0.7-1.3	1.5-2.9	1.7	0.5	1.1	108	72	245	8202 0750 01
COL 1 02	1.0-2.0	2.2-4.4	1.7	0.5	1.1	108	72	245	8202 0750 19

NOTE: Comes with nylon cable.

Dimensions

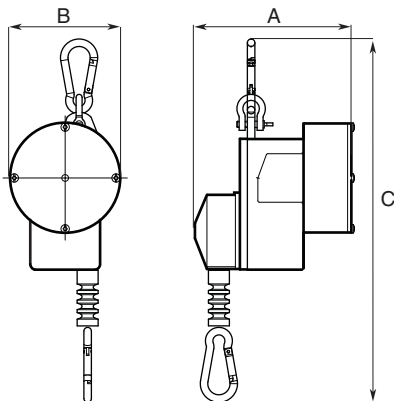

Optional Accessories

SAFETY CHAIN

	Ordering No.
COL 1	4391 4045 90

RIL BALANCER

RIL balancers always keep the tool in place, handy and easily accessible. RIL balancers are available as retractors or weightless positioning balancers.

Safety chain included with all RIL balancers.

RIL RETRACTORS

- Adjustable wire stop.
- High quality spring and construction.
- Load range 0 to 10 kg.



Dimensions

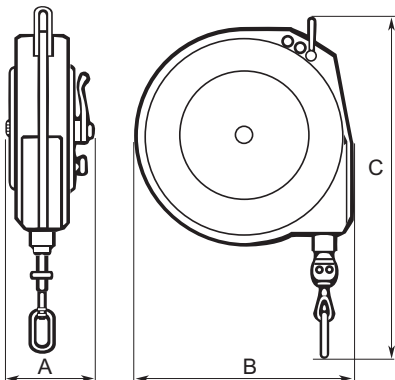

Model	Capacity range		Cable length m	Weight		Dimensions			Ordering No.
	kg	lb		kg	lb	A mm	B mm	C mm	
Retractors									
RIL 1C	0.0-0.5	0.0-1.7	1.5	0.6	1.3	51	106	238	8202 0700 02
RIL 2C	0.4-1.0	0.9-2.2	1.5	0.6	1.3	51	106	238	8202 0701 19
RIL 4C	1.0-2.0	2.2-4.4	1.5	0.6	1.3	51	106	238	8202 0702 18
RIL 5C	1.4-2.3	3.1-5.1	1.5	0.6	1.3	51	106	238	8202 0703 25
RIL 10C	2.0-5.0	4.4-11.0	2.4	2.7	6.0	84	190	369	8202 0704 16
RIL 10CS ^a	2.0-5.0	4.4-11.0	2.4	2.7	6.0	84	190	369	8202 0704 20
RIL 15C	5.0-7.0	11.0-15.4	2.4	3.2	7.1	84	190	369	8202 0705 15
RIL 15CS ^a	5.0-7.0	11.0-15.4	2.4	3.2	7.1	84	190	369	8202 0705 20
RIL 22C	6.0-10.0	13.2-22.0	2.4	3.2	7.1	84	190	369	8202 0706 14
RIL 22CS ^a	6.0-10.0	13.2-22.0	2.4	3.2	7.1	84	190	369	8202 0706 20

^a Balancer equipped with automatic safety drum lock in case of spring failure.

NOTE: RIL 1C, 2C, 4C and 5C comes with nylon cable. All other models are equipped with steel wire.

Accessories

SAFETY CHAIN

	Ordering No.
1C, 2C, 4C and 5C	4391 4045 90
10C, 15C and 22C	4391 4156 00

WP BALANCER

Weightless positioning balancers with a cone-shaped drum hold the load and keep it weightless throughout the entire cable length. The casing for WP 05/10 are in plastic, the WP 20 in aluminium and the WP 30 models are in abrasion resistant aluminium.

All models except for the WP 20 comes with a swiveling safety hook.

PRODUCTIVITY

WP balancers always hold the tool in the correct position and minimize worker fatigue.

ERGONOMIC

WP balancers reduce stress level in the operator's muscles.

SAFETY

The load is not pulled back when released and the environment is protected from accidental hoisting of the load.

- Steel cable with cable stop buffer.
- Safety chain.
- Quick and easy cable replacement.
- Available with extended cable lengths for roof mounting. (A) -models



Dimensions

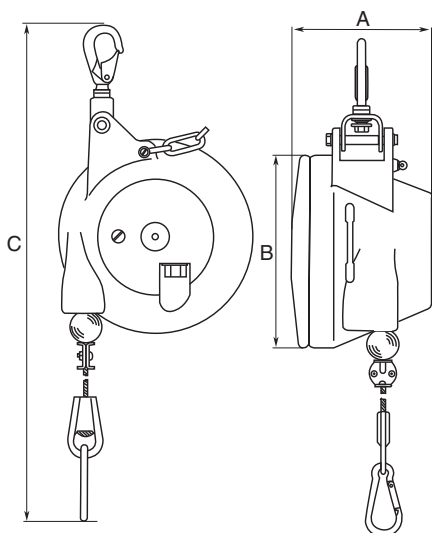

Model	Capacity range		Cable length		Weight		Dimension			Ordering No.
	kg	lb	m	ft	kg	lb	A mm	B mm	C mm	
WP 05 - Standard										
WP 05-1	0.4-1.2	0.9-2.6	2	6.5	1.3	2.9	71	141	460	8202 0778 00
WP 05-3	1.2-2.6	2.6-5.7	2	6.5	1.4	3.1	71	141	460	8202 0778 01
WP 05-4	2.6-3.8	5.7-8.4	2	6.5	1.5	3.3	71	141	460	8202 0778 02
WP 05-5	3.8-5.2	8.4-11.5	2	6.5	1.5	3.3	71	141	460	8202 0778 03
WP 05-6	5.2-6.5	11.5-14.3	2	6.5	1.5	3.3	71	141	460	8202 0778 04
WP 05 - Extended Cable - A										
WP 05-1-A	0.4-1.2	0.9-2.6	5.5	18	1.3	2.9	71	141	460	8202 0778 05
WP 05-3-A	1.2-2.6	2.6-5.7	5.5	18	1.4	3.1	71	141	460	8202 0778 06
WP 05-4-A	2.6-3.8	5.7-8.4	5.5	18	1.5	3.3	71	141	460	8202 0778 07
WP 05-5-A	3.8-5.2	8.4-11.5	5.5	18	1.5	3.3	71	141	460	8202 0778 08
WP 05-6-A	5.2-6.5	11.5-14.3	5.5	18	1.5	3.3	71	141	460	8202 0778 09
WP 10 - Standard										
WP 10-3	3-5	6.6-11	2	6.5	2.9	6.4	130	188	521	8202 0779 00
WP 10-4.5	4.5-7	10-15.4	2	6.5	3.1	6.8	130	188	521	8202 0779 01
WP 10-6	6-10	13-22	2	6.5	3.2	7.0	130	188	521	8202 0779 02
WP 10-9	9-14	20-31	2	6.5	3.4	7.5	130	188	521	8202 0779 03
WP 10-13	13-17	29-37	2	6.5	3.6	8.0	130	188	521	8202 0779 04
WP 10-16	16-21	35-46	2	6.5	3.8	8.4	130	188	521	8202 0779 05
WP 10 - Extended Cable - A										
WP 10-3-A	3-5	6.6-11	5.5	18	2.9	6.4	130	188	521	8202 0779 06
WP 10-4.5-A	4.5-7	10-15.4	5.5	18	3.1	6.8	130	188	521	8202 0779 07
WP 10-6-A	6-10	13-22	5.5	18	3.2	7.0	130	188	521	8202 0779 08
WP 10-9-A	9-14	20-31	5.5	18	3.4	7.5	130	188	521	8202 0779 09
WP 10-13-A	13-17	29-37	5.5	18	3.6	8.0	130	188	521	8202 0779 10
WP 10-16-A	16-21	35-46	5.5	18	3.8	8.4	130	188	521	8202 0779 11
WP 20 - Standard										
WP 20-15	15-25	33-55	2	6.5	7.8	17.2	152	218	521	8202 0780 00
WP 20-25	25-35	55-77	2	6.5	8.9	19.6	152	218	521	8202 0780 01
WP 20-35	35-45	77-99	2	6.5	9.5	21.0	152	218	521	8202 0780 02
WP 20-45	45-55	99-121	2	6.5	9.8	21.5	152	218	521	8202 0780 03
WP 30 - Standard										
WP 30-12	12-20	26-44	2	6.5	14.8	32.6	203	285	749	8202 0781 00
WP 30-20	20-30	44-66	2	6.5	15.2	33.5	203	285	749	8202 0781 01
WP 30-30	30-45	66-99	2	6.5	16.9	37.3	203	285	749	8202 0781 02
WP 30-45	45-60	99-132	2	6.5	17.3	38.1	203	285	749	8202 0781 03
WP 30-60	60-75	132-165	2	6.5	18.7	41.2	203	285	749	8202 0781 04
WP 30-75	75-90	165-198	2	6.5	19.7	43.4	203	285	749	8202 0781 05
WP 30-90	90-100	198-220	2	6.5	19.9	43.4	203	285	749	8202 0781 06
WP 40 - Standard										
WP 40-100	100-115	220-254	3	10	42.0	43.9	348	320	800	8202 0782 00
WP 40-115	115-130	254-287	3	10	44.0	97.0	348	320	800	8202 0782 01
WP 40-130	130-140	287-309	3	10	46.0	101	348	320	800	8202 0782 02
WP 40-140	140-150	309-331	3	10	48.0	106	348	320	800	8202 0782 03