

Reich

KUPPLUNGEN

ARCUSAFLEX

Highly torsionally flexible
rubber disc coupling
for internal combustion engine drives



Contents

	page
General	3
Types	4
Technical details - standard version with single element	6
Technical details - standard version with 2 elements operating in tandem	7
Technical details - silicone version	8
Materials / Selection of the proper coupling size	9
Dimensional details of ARCUSAFLEX flywheel couplings Type AC-T...F2 with taper bush	10
Dimensional details of ARCUSAFLEX flywheel couplings Type AC...F2 with bolted hub	11
Dimensional details of ARCUSAFLEX flywheel couplings Type AC...F2K with bolted hub for radial element change	12
Dimensional details of ARCUSAFLEX shaft couplings Type AC-T...T and type AC...TK	13
Dimensional details of ARCUSAFLEX flywheel couplings Type AC...D.F2 with 2 elements operating in tandem	14
Dimensional details of ARCUSAFLEX flywheel couplings Type AC...D.F2K with 2 elements operating in tandem and for radial element change	15
Mounting instruction for ARCUSAFLEX flywheel couplings Type AC-T...F2 with taper bush	16
Mounting instruction for ARCUSAFLEX flywheel couplings Tightening torques for ARCUSAFLEX couplings	17
Mounting instruction for ARCUSAFLEX flywheel couplings Alignment / Permissible shaft displacement	18
Requested Data for Coupling Selection / Torsional Vibration Calculation	19

February 2006 Edition

This ARCUSAFLEX edition supercedes all previous catalogues of this coupling type. All dimensions in millimeters. We reserve the right to change dimensions and/or design details without prior notice.

Proprietary notice pursuant to ISO 16016 to be observed:

The reproduction, distribution and utilization of this document as well as the communication of its contents to others without explicit authorization is prohibited. Offenders will be held liable for the payment of damages. All rights reserved in the event of the grant of a patent, utility model or design. © REICH-KUPPLUNGEN

General



ARCUSAFLEX coupling design AC

The ARCUSAFLEX coupling is a highly flexible flywheel coupling with an axial plug-in facility. It provides a torsionally soft connection between an internal combustion engine and a driven machine.

The highly flexible torque transmission characteristic is achieved by a disc-shaped rubber element that is subjected to a torsional load and enables both, the absorption of high torsional vibrations and the compensation of major misalignments. For an optimum adaptation to the conditions of application three different kinds of vulcanisates are available: For application temperatures up to 80°C a natural/synthetic caoutchouc mixture as a standard version, up to 100°C a more heat resistant mixture and for higher application temperatures up to 130°C a silicone mixture.

The inside diameter of the rubber disc element is vulcanized directly to a taper hub or bolt-on sleeve. The toothed profile on the circumference of the element provides in service a virtually backlash-free, positive plug-in connection to the coupling flange.

The ARCUSAFLEX flywheel coupling series covers a torque range from 200 - 110000 Nm (corresponding to approx. 6500 kW at 1000 rpm). Element versions of different torsional stiffnesses are available for optimizing the torsional vibration range. The flange connection dimensions of ARCUSAFLEX couplings comply predominantly with the SAE J 620 and DIN 6281 standards. Other flange dimensions or overall lengths can be provided on request.

Shaft-to-shaft connections when required can be met by ARCUSAFLEX shaft couplings which consist of ARCUSAFLEX flywheel couplings of the standard design equipped with a second hub.

Type approvals by a number of leading classification societies are available. If required, couplings complete with fail safe devices can also be supplied.

ARCUSAFLEX couplings comply to explosion protection according to ATEX 95. They are certified according to the directive 94/9/EC and may be used in hazardous locations (categories M2, 2 + 3).

Main features of the highly flexible ARCUSAFLEX couplings

- Very high torsional flexibility with a linear torsional deflection characteristic
- High torsional vibration and shock load absorbing capability
- Backlash-free torque transmission
- Ease of assembly thanks to the plug-in type design with ample axial float
- Compensation of major misalignments
- Torque limitation protecting the drive against overload
-  ATEX 95

Types

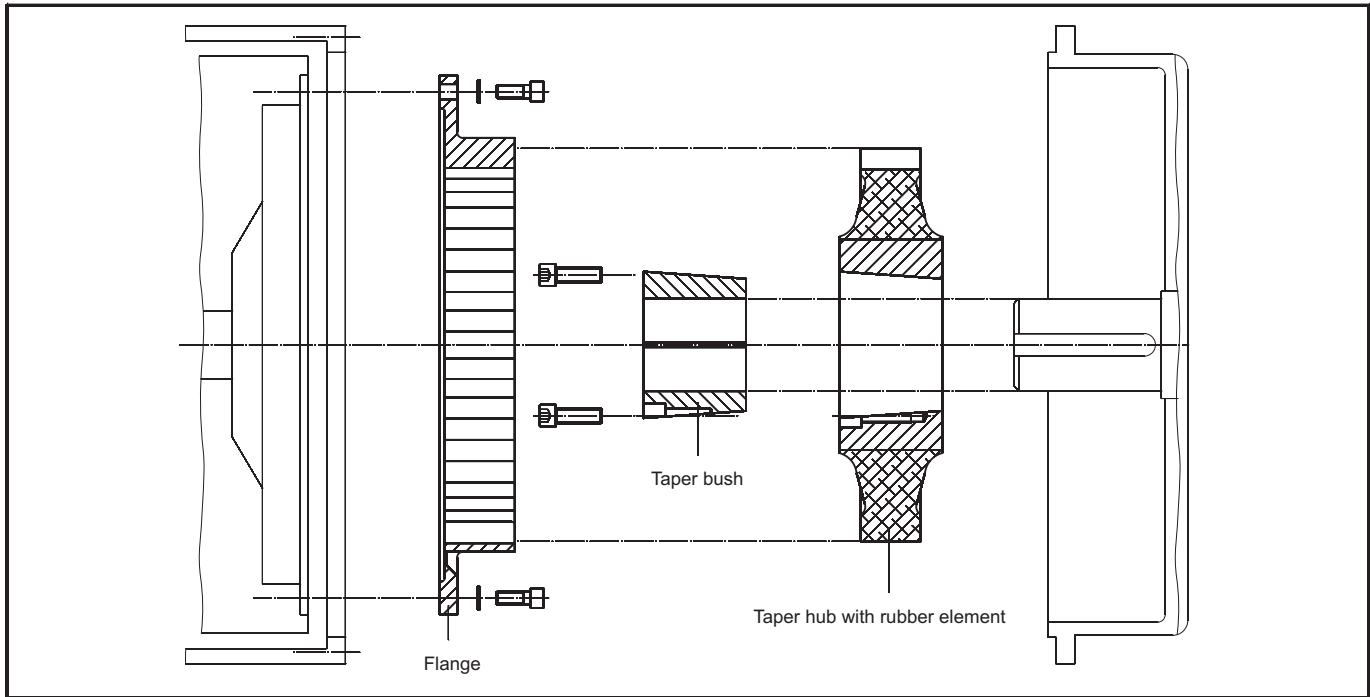

ARCUSAFLEX type AC-T with taper bush

The ARCUSAFLEX flywheel coupling type AC-T...F2 is equipped with a taper bush for shaft mounting. The rubber disc element is vulcanized directly to the taper hub. After completion of the assembly, a shrink-fit-like connection, free from backlash is established between the coupling hub with rubber disc element and the shaft.

Thanks to the use of commercially available taper bushes with a number of different bore dimensions, the need for finishing the bore and keyway of the coupling hub is omitted for the ARCUSAFLEX coupling type AC-T. The torque, which can be transmitted, depends on the particular taper bush.

Advantage: Ease of assembly and disassembly with no need for special tools!

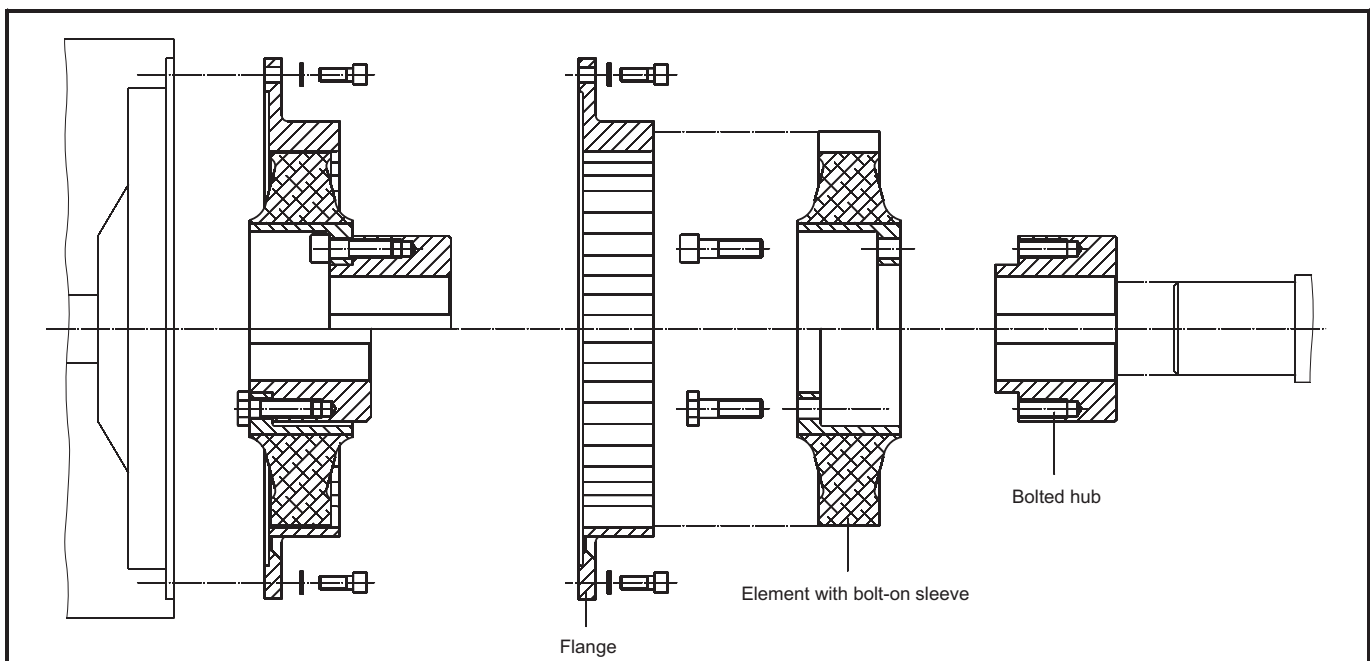

ARCUSAFLEX type AC...F2 with bolted hub

The ARCUSAFLEX flywheel coupling type AC...F2 has the rubber disc element vulcanized to a bolt-on sleeve which in turn is bolted to a hub or similar component.

Advantage: Depending on the arrangement of the rubber disc element, two different mounting lengths can be achieved using one and the same coupling hub.

Types

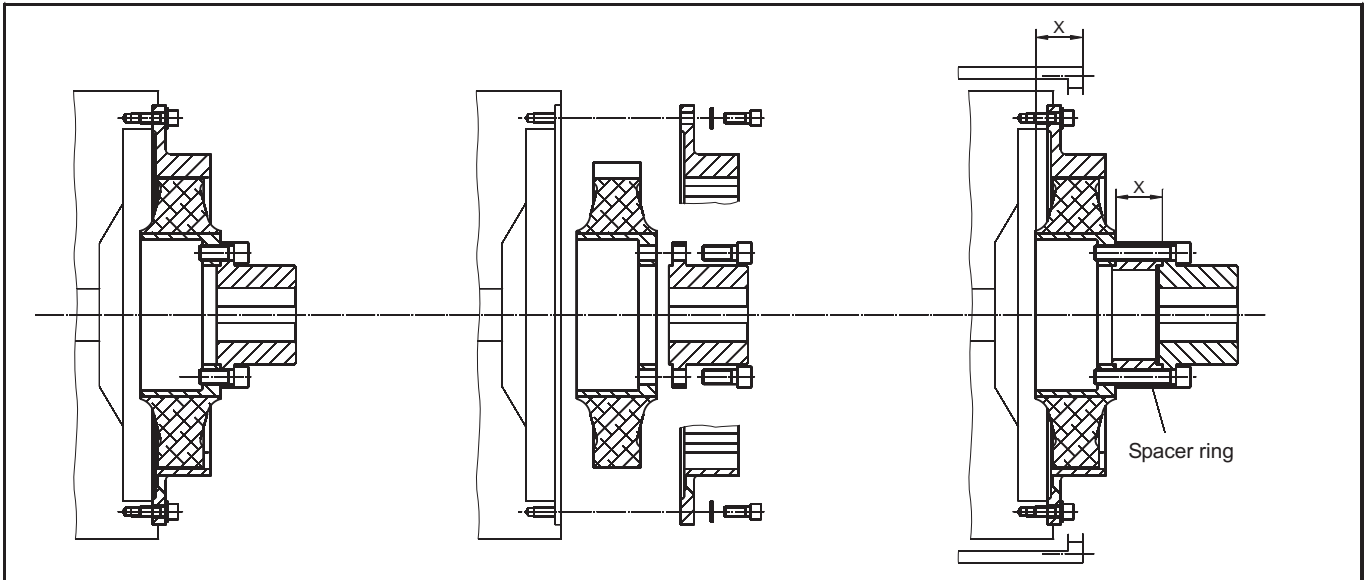

ARCUSAFLEX type AC...F2K for radial element change

Type AC...F2K permits changing the detached element without having to move the coupled machines. Where the flywheel or flywheel housing protrudes excessively from the element, a spacer ring corresponding to oversize X is required for radial removal.

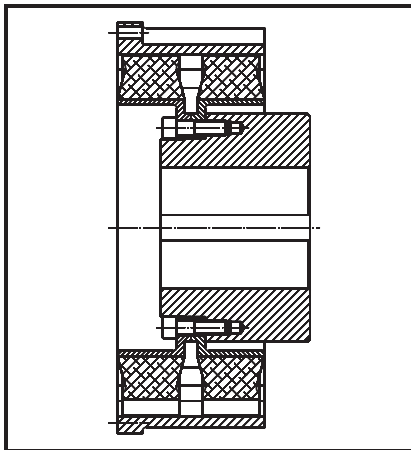

ARCUSAFLEX flywheel coupling type AC...D F2 with 2 elements operating in tandem

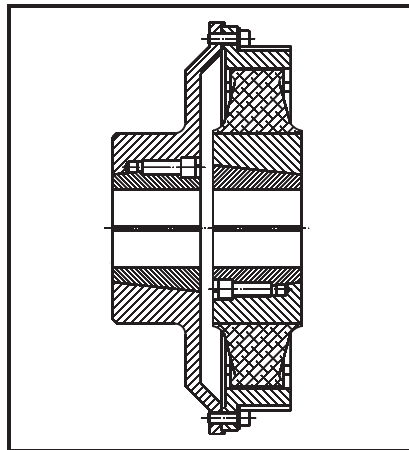

ARCUSAFLEX shaft coupling type AC-T...T

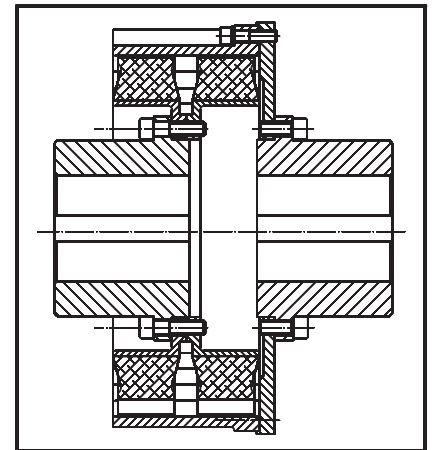

ARCUSAFLEX shaft coupling type AC...D TK with 2 elements operating in tandem

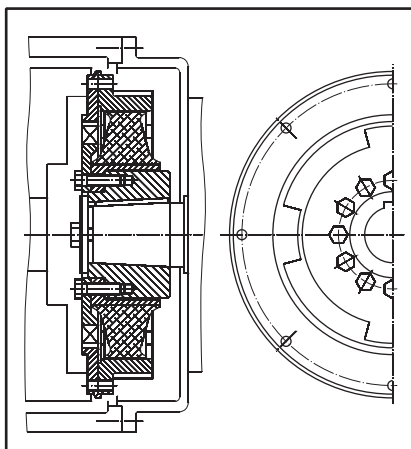

ARCUSAFLEX flywheel coupling type AC...DS
with fail safe device, to be mounted between an internal combustion engine and a marine gearbox.

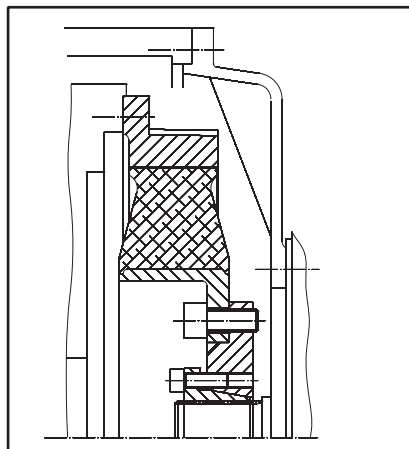

ARCUSAFLEX flywheel coupling with splined clamping hub, to be mounted between an internal combustion engine and a pump drive.

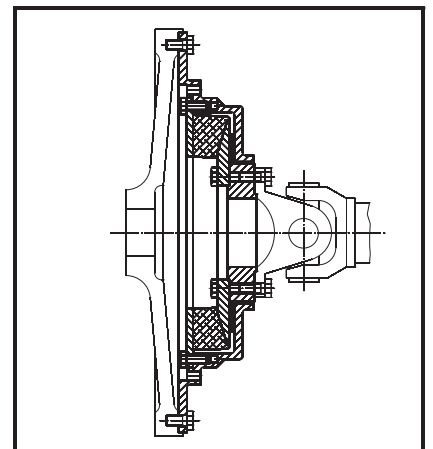

ARCUSAFLEX flywheel coupling design AC-VSK...
with integral bearing, to be mounted to internal combustion engines as an U-joint coupling in conjunction with a cardan shaft. Extra folder is available.

Technical details

Standard version with 1 element - Natural/synthetic caoutchouc mixture NR/SBR

ARCUSAFLEX coupling size	Element version	Nominal torque	Maximum torque	Fatigue torque *)	Dynamic torsional stiffness	Flange size	Max. speed
		T _{KN} [Nm]	T _{Kmax} [Nm]	T _{KW} (10 Hz) [Nm]	C _{T dyn} [Nm/rad]	SAE J 620	n _{max} [rpm]
AC 2,3	WN	330	750	165	1100	6.5 - 8 10	4200 3600
	NN	360	900	180	1700		
	SN	400	1000	200	2500		
	UN	450	1000	225	3500		
AC 2,6	WN	500	1250	250	2100	8 10 11.5	4200 3600 3500
	NN	600	1800	300	3100		
	SN	700	2100	350	4500		
	UN	800	2100	400	6300		
AC 3	WN	800	2000	400	3600	10 11.5	3600 3500
	NN	900	2700	450	5000		
	SN	1000	3000	500	7500		
	UN	1150	3000	575	10500		
AC 4 / 4.1	WN	1200	3000	600	8000	10 11.5 14	3600 3500 3000
	NN	1350	3600	650	10000		
	SN	1550	4200	750	13500		
	UN	1800	4200	900	19000		
AC 4,9	WN	1400	3500	700	10000	11.5 14	3200 3000
	NN	1800	4500	900	15000		
	SN	2300	5500	1150	24000		
	UN	2700	5500	1350	34000		
AC 5 / 5.1	WN	1800	4500	900	8500	11.5 14	3200 3000
	NN	2000	5400	1000	13000		
	SN	2500	7500	1250	22000		
	UN	2900	7500	1450	31000		
AC 6 / 6.1	WN	3100	7700	1500	16000	14 18	3000 2300
	NN	3450	10000	1700	30000		
	SN	4200	12600	2100	45000		
	UN	4800	12600	2400	63000		
AC 6,5	WN	4000	10000	2000	25000	14	3000
	NN	4500	13500	2250	40000		
	SN	5500	16500	2750	72000		
	UN	6200	16500	3100	100000		
AC 7	WN	4600	10000	2300	35000	14 18	2600 2300
	NN	5200	15600	2600	56000		
	SN	6300	18900	3100	100000		
	UN	7400	18900	3700	140000		
AC 8	WN	6200	14000	3100	38000	18 21	2300 2000
	NN	7000	21000	3500	75000		
	SN	7800	23400	3900	110000		
	UN	9200	23400	4600	160000		
AC 9	WN	8000	18000	4200	55000	18 21	2300 2000
	NN	9000	27000	4800	100000		
	SN	10000	30000	5500	190000		
	UN	12000	30000	6000	300000		
AC 10	WN	11000	28000	5500	75000	18 21	2300 2000
	NN	12500	37000	6250	120000		
	SN	14000	42000	7000	210000		
	UN	16000	42000	8000	320000		
AC 11	WN	16000	40000	8000	150000	21 24	2000 1800
	NN	18000	54000	9000	250000		
	SN	20000	60000	10000	450000		
	UN	23000	60000	11500	650000		
AC 12	WN	25000	75000	12500	250000	similar to DIN 6288	1500
	NN	28000	84000	14000	400000		
	SN	31500	94000	15000	700000		
	UN	36000	94000	18000	1000000		
AC 13	WN	40000	120000	20000	375000	on request	1500
	NN	45000	135000	21250	600000		
	SN	50000	150000	22500	1050000		
	UN	55000	150000	25000	1400000		

Element versions: WN = 55° Shore A; NN = 65° Shore A; SN = 75° Shore A; UN = 85° Shore A

Due to the physical characteristics of the rubber materials the measurable rubber hardness is subject to a dispersion, which is defined according to DIN 53505 with ± 5° Shore A. Because of in-house manufacturing this dispersion of the shore hardness can be minimized.

*) Continuous fatigue torque under reversing stresses ± T_{KW} at f = 10 Hz; for other frequencies f_x apply T_{KW} · √(10/f_x)

Technical details

Standard version with 2 elements - Natural/synthetic caoutchouc mixture NR/SBR

ARCUSAFLEX coupling size	Element version	Nominal torque	Maximum torque	Fatigue torque *)	Dynamic torsional stiffness	Flange size to SAE J 620	Max. speed
		T_{KN} [Nm]	T_{Kmax} [Nm]	T_{KW} (10 Hz) [Nm]	$C_{T dyn}$ [Nm/rad]		n_{max} [rpm]
AC 8D	WN	12400	28000	6200	76000	18 21	2300 2000
	NN	14000	42000	7000	150000		
	SN	15600	46800	7800	220000		
	UN	18400	46800	9200	320000		
AC 9D	WN	16000	36000	8400	110000	18 21 24	2000 2000 1800
	NN	18000	54000	9600	200000		
	SN	20000	60000	11000	380000		
	UN	24000	60000	12000	600000		
AC 10 D	WN	22000	56000	11000	150000	21 24	2000 1800
	NN	25000	74000	12500	240000		
	SN	28000	84000	14000	420000		
	UN	32000	84000	16000	640000		
AC 11 D	WN	32000	80000	16000	300000	21 24	2000 1800
	NN	36000	108000	18000	500000		
	SN	40000	120000	20000	900000		
	UN	46000	120000	23000	1300000		
AC 12 D	WN	50000	150000	25000	500000	similar to DIN 6288	1300
	NN	56000	168000	28000	800000		
	SN	63000	189000	30000	1400000		
	UN	72000	189000	36000	2000000		
AC 13 D	WN	80000	240000	40000	750000	on request	1300
	NN	90000	270000	42500	1200000		
	SN	100000	300000	45000	2100000		
	UN	110000	300000	50000	2800000		

Element versions: WN = 55° Shore A; NN = 65° Shore A; SN = 75° Shore A; UN = 85° Shore A

Due to the physical characteristics of the rubber materials the measurable rubber hardness is subject to a dispersion, which is defined according to DIN 53505 with $\pm 5^\circ$ Shore A. Because of in-house manufacturing this dispersion of the shore hardness can be minimized.

*) Continuous fatigue torque under reversing stresses $\pm T_{KW}$ at $f = 10$ Hz; for other frequencies f_x apply $T_{KW} \cdot \sqrt{\frac{10}{f_x}}$

Resonance factor V_R and relative damping Ψ

Element version	V_R	Ψ
WN	7.85	0.80
NN	5.46	1.15
SN	5.03	1.25
UN	4.83	1.30

Technical note :

The technical data applies only to the complete coupling or the corresponding coupling elements. It is the customer's/user's responsibility to ensure there are no inadmissible loads acting on all the components. Especially existing SAE bolt connections have to be checked regarding the transmittable torque, if necessary other measures, e.g. additional reinforcement by pins, may be required. It is also the customer's/user's responsibility to make sure the dimensioning of the shaft and keyed or other connection is correct. With the type AC-T...F2 the transmittable torque is dependant among others on the torque capacity of the taper bush.

REICH-KUPPLUNGEN have an extensive programme of couplings to cover nearly every drive configuration. Furthermore customized solutions can be developed and be manufactured also in small series or as prototypes. Calculation programmes are available for coupling selection and sizing. - Please challenge us!

Technical details

Silicone Version

ARCUSAFLEX coupling size	Element version	Nominal torque	Maximum torque	Maximum torque	Fatigue torque *)	Dynamic torsional stiffness $C_{T \text{ dyn}}$ [Nm/rad]				
		T_{KN} [Nm]	T_{Kmax1} [Nm]	T_{Kmax2} [Nm]	T_{KW} (10 Hz) [Nm]	0.10 T_{KN}	0.25 T_{KN}	0.50 T_{KN}	0.75 T_{KN}	1.00 T_{KN}
AC 2,3	WX	300	450	600	130	600	800	900	1300	1700
AC 2,6	WX	450	675	900	200	1000	1400	1700	2400	3100
AC 3	WX	750	1125	1500	320	1900	2400	3000	4200	5400
AC 4 / 4.1	WX	1150	1725	2300	480	4200	5300	6600	9300	12000
AC 4,9	WX	1600	2400	3200	640	4400	5500	6900	9600	12500
AC 5 / 5.1	WX	1800	2700	3600	720	4500	5600	7000	9800	12700
AC 6 / 6.1	WX	3000	4500	6000	1200	10600	13000	16000	23000	30000
AC 6,5	WX	3800	5700	7600	1500	15000	18000	23000	33000	41000
AC 7	WX	4500	6750	9000	1800	18600	23000	29000	41000	53000
AC 8	WX	6100	9150	12200	2400	26000	33000	41000	58000	75000
AC 8D	WX	12200	18300	24400	4800	52000	66000	82000	116000	150000
AC 9	WX	7500	11250	15000	3300	29000	36500	45700	64000	83000
AC 9D	WX	15000	22500	30000	6600	58000	73000	91400	128000	166000
AC 10	WX	10000	15000	20000	4000	40000	49000	61000	87000	113000
AC 10D	WX	20000	30000	40000	8000	80000	98000	122000	174000	226000
AC 11	WX	15000	22500	30000	6000	79000	100000	123000	172000	225000
AC 11D	WX	30000	45000	60000	12000	158000	200000	246000	344000	450000
AC 12	WX	22500	33750	45000	9000	225000	263000	316000	376000	480000
AC 12D	WX	45000	67500	90000	18000	450000	526000	632000	752000	960000

Element version: WX = 60 ± 5° Shore A

*) Continuous fatigue torque under reversing stresses ± T_{KW} at $f = 10$ Hz; for other frequencies f_x apply $T_{KW} \cdot \sqrt{\frac{10}{f_x}}$

Additional information for selection of couplings with silicone elements:

1.6 - 2.0 $T_{AN} \leq T_{KN}$ T_{AN} = nominal torque of the drive

T_{Kmax1} is the highest permissible maximum torque of the application taking for example into account starting, stopping and running through the resonance speed.

T_{Kmax2} is the highest permissible peak torque, which can occur with a limited number of application related conditions, e.g. short-circuit, synchronization failure, emergency stop.

Resonance factor V_R and relative damping Ψ

Element version	V_R	Ψ
WX	5.46	1.15

Materials of the ARCUSAFLEX flywheel couplings

- Coupling flanges: AC 2,3 – AC 10 D high grade aluminium casting
AC 6,5 ; AC 11 - AC 13 D of spheroidal cast iron grade GGG 50
- Rubber disc element:
 - Standard version natural/synthetic caoutchouc mixture for ambient temperatures from –40°C up to +80°C
 - More heat resistant natural/synthetic caoutchouc mixture for ambient temperatures from –25°C up to +100°C
 - Silicone mixture for ambient temperatures from –60°C up to 130°C
- Type AC-T: Taper hub and taper bush of grey cast iron grade GG 25
- Type AC with bolted hub: Bolt-on sleeve of spheroidal cast iron grade GGG 40 / bolted hub of steel (min. yield strength 360 MPa)

Selection of the proper coupling size

The coupling size to be used in conjunction with internal combustion engines is dimensioned and selected with a view to torsional vibration. For a preliminary selection use the engine torque T_{AN} , a general safety factor of $S = 1.3 - 1.5$ should be applied for ARCUSAFLEX couplings with flexible rubber disc elements of natural/synthetic caoutchouc.

The following requirements should be satisfied for a proper selection of the coupling size:

1. The **nominal torque capacity** T_{KN} of the coupling should be at least equal to the max. engine torque T_{AN} at any operating temperature while taking the temperature factor S_t into account.

$$T_{KN} \geq T_{AN} \cdot S_t$$

Calculation of the nominal engine torque:

$$T_{AN} [\text{Nm}] = 9550 \cdot \frac{P[\text{kW}]}{n[\text{rpm}]}$$

The temperature factor S_t allows for a decreasing load carrying capability of the coupling at elevated ambient temperatures. In this connection $S_t = S_{t1}$ is valid for the standard version and $S_t = S_{t2}$ is valid for the silicone version.

	60°C	70°C	80°C	90°C	100°C	110°C	120°C	130°C
S_{t1}	1.25	1.4	1.6	on request	-	-	-	-
S_{t2}	1.5	1.5	1.5	1.7	1.9	2.1	2.3	2.5

2. The **maximum torque capacity** T_{Kmax} of the coupling should be at least equal to the highest torque T_{max} at any operating temperature while taking the temperature factor S_t into account.

$$T_{Kmax} \geq T_{max} \cdot S_t$$

3. The permissible **continuous fatigue torque under reversing stresses** T_{KW} of the coupling should be at least equal to the highest fatigue torque under reversing stresses T_W encountered throughout the operating speed range while taking the temperature and frequency into account. The frequency factor S_f allows for the frequency dependence of the permissible continuous fatigue torque under reversing stresses $T_{KW(10\text{ Hz})}$ for other frequencies f_x .

$$T_{KW(10\text{ Hz})} \geq T_W \cdot S_t \cdot S_f$$

$$S_f = \sqrt{\frac{f_x}{10}}$$

The dimensioning of the coupling should be checked for permissible coupling loads by means of a torsional vibration analysis which will be conducted by us on request. When using ARCUSAFLEX couplings in drives with great torque transmission variations, an additional safety factor should be applied for torque transmission to the driven machine. Lists specifying couplings assigned to different ratings and torsional vibration conditions are available for all common internal combustion engines operating at constant speeds to facilitate your selection of an operationally safe coupling.

The coupling can be equipped with an additional balancing mass on the primary or secondary side, if this is required due to the torsional vibration conditions or for control reasons.

Further information for the torsional vibration calculation and for use of the ARCUSAFLEX rubber disc coupling are available upon request.

ARCUSAFLEX flywheel couplings

Type AC-T...F2 with taper bush

Flange connecting dimensions to SAE J 620 d and mounting dimensions to DIN 6281

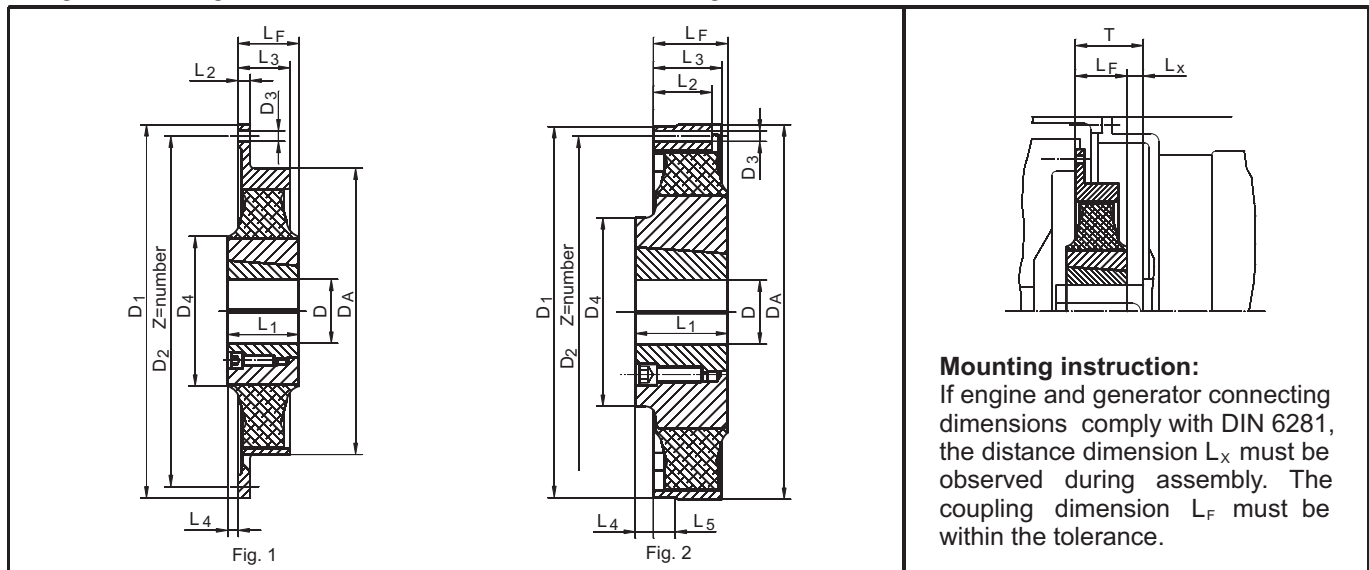

ARCUSAFLEX coupling size	Fig.	Flange connection SAE J 620						Taper-bush No.	DIN 6281							J ₁ outside [kgm ²]	J ₂ inside [kgm ²]	Total weight [kg]		
		SAE size	D ₁	D ₂	D ₃	Z	D _A		D ₄	L ₁	L ₂	L ₃	L ₄	L ₅	L _F				T	L _x
AC-T 2,3.*)-F2	-	6.5	215.9	200.0	8.5	6	2012	222	-	32	6	41	-	8	52±2	-	-	0.008	0.008	3.6
	2	7.5	241.3	222.3	8.5	8	2012	222	-	32	33	33	-	8	43±3	-	-	0.008	0.008	3.5
	1	8	263.5	244.5	10.5	6	2012	222	-	32	8	33	-	-	43±3	81.0	38	0.011	0.008	3.7
	1	10	314.3	295.3	10.5	8	2012	222	-	32	8	33	-	-	43±3	73.0	40	0.020	0.008	4.2
AC-T 2,6.*)-F2	2	8	263.5	244.5	10.5	6	2517	263	150	45	33	38	3	10	42±4	81.0	41	0.011	0.019	5.9
	1	10	314.3	295.3	10.5	8	2517	263	150	45	10	38	3	-	42±4	73.0	31	0.017	0.019	6.2
	1	11.5	352.4	333.4	10.5	8	2517	263	150	45	10	38	3	-	42±4	58.6	16	0.024	0.019	6.5
AC-T 3.*)-F2	1	10	314.3	295.3	10.5	8	2517	290	150	64	16	52	6	-	58±7	73.0	14	0.026	0.026	8.5
	1	11.5	352.4	333.4	10.5	8	2517	290	150	64	16	52	6	-	58±7	58.6	0	0.036	0.026	8.8
AC-T 4.*)-F2	2	10	314.3	295.3	10.5	8	3030	320	175	76	56	56	8	8	68±6	73.0	4	0.042	0.059	13.7
	1	11.5	352.4	333.4	10.5	8	3030	320	175	76	16	60	8	-	68±6	106.6	39	0.062	0.059	14.1
	1	14	466.7	438.2	13.0	8	3030	320	175	76	16	60	8	-	68±6	92.4	25	0.181	0.059	16.9
AC-T 4,9.*)-F2	1	11.5	352.4	333.4	10.5	8	3535	320	180	89	16	77	-	-	92±7	106.6	14	0.080	0.097	16.8
	1	14	466.7	438.2	13.0	8	3535	320	180	89	16	77	-	-	92±7	92.4	0	0.125	0.097	17.9
AC-T 5.*)-F2	2	11.5	352.4	333.4	10.5	8	3535	354	210	89	54	65	13	20	76±5	106.6	30	0.065	0.131	21.0
	1	14	466.7	438.2	13.0	8	3535	354	210	89	15	65	13	-	76±5	92.4	17	0.179	0.131	24.2
AC-T 6.*)-F2	1	14	466.7	438.2	13.0	8	4040	420	240	102	18	80	10	-	92±7	92.4	0	0.220	0.334	37.0
	1	16	517.5	489.0	13.0	8	4040	420	240	102	18	80	10	-	92±7	82.7	0	0.320	0.334	37.5
	1	18	571.5	542.9	17.0	6	4040	420	240	102	18	80	10	-	92±7	82.7	0	0.470	0.334	40.6
AC-T 6,5.*)-F2	1	14	466.7	438.2	13.0	8	4535	420	-	90	18	90	-	-	92±4	92.4	0	0.688	0.432	52.6
AC-T 7.*)-F2	2	14	466.7	438.2	13.0	8	4545	465	235	115	85	85	28	27	87±10	92.4	5	0.312	0.761	62.8
	1	16	517.5	489.0	13.0	8	4545	465	235	115	27	85	28	-	87±10	82.7	0	0.411	0.761	64.2
	1	18	571.5	542.9	17.0	6	4545	465	235	115	18	85	28	-	87±10	82.7	0	0.519	0.761	67.5
AC-T 8.*)-F2	1	18	571.5	542.9	17.0	12	5040	514	-	102	18	84	0	-	102±7	-	-	0.478	1.058	61.4
	1	21	673.1	641.4	17.0	12	5040	514	-	102	18	84	0	-	102±7	-	-	0.948	1.058	66.2
AC-T 9.*)-F2	1	18	571.5	542.9	17.0	12	5040	560	-	102	35	92	0	-	102±4	-	-	0.846	1.605	80.5
	1	21	673.1	641.4	17.0	12	5040	560	-	102	20	92	0	-	102±4	-	-	1.422	1.605	87.0

*) For the element versions, see "Technical details"

Available taper bushes:

No.	Metric bores with keyway acc. to DIN 6885/1																		
2012	14	16	17	19	20	22	24	25	28	30	32	35	38	40	42	45	48		
2517	16	18	19	20	22	24	25	28	30	32	35	38	40	42	45	48	50	55	60
3030	25	28	30	32	35	38	40	42	45	48	50	55	60	65	70	75			
3535	35	38	40	42	45	48	50	55	60	65	70	75	80	85	90				
4040	40	42	45	48	50	55	60	65	70	75	80	85	90	95	100				
4535	55	60	65	70	75	80	85	90	95	100	105	110							
4545	55	60	65	70	75	80	85	90	95	100	105	110							
5040	70	75	80	85	90	95	100	105	110	115	120	125							

Taper bushes with imperial size bores can also be supplied.

Ordering example: Coupling designation: **AC-T4. NN. F2. 14. 3030. 65**
 ARCUSAFLEX coupling size _____
 Element version acc. to "Technical details" _____
 Size of flange connection to SAE J 620 _____
 Nominal size of taper bush _____
 Bore diameter _____

ARCUSAFLEX flywheel couplings

Type AC...F2 with bolted hub

Flange connecting dimensions to SAE J 620 d

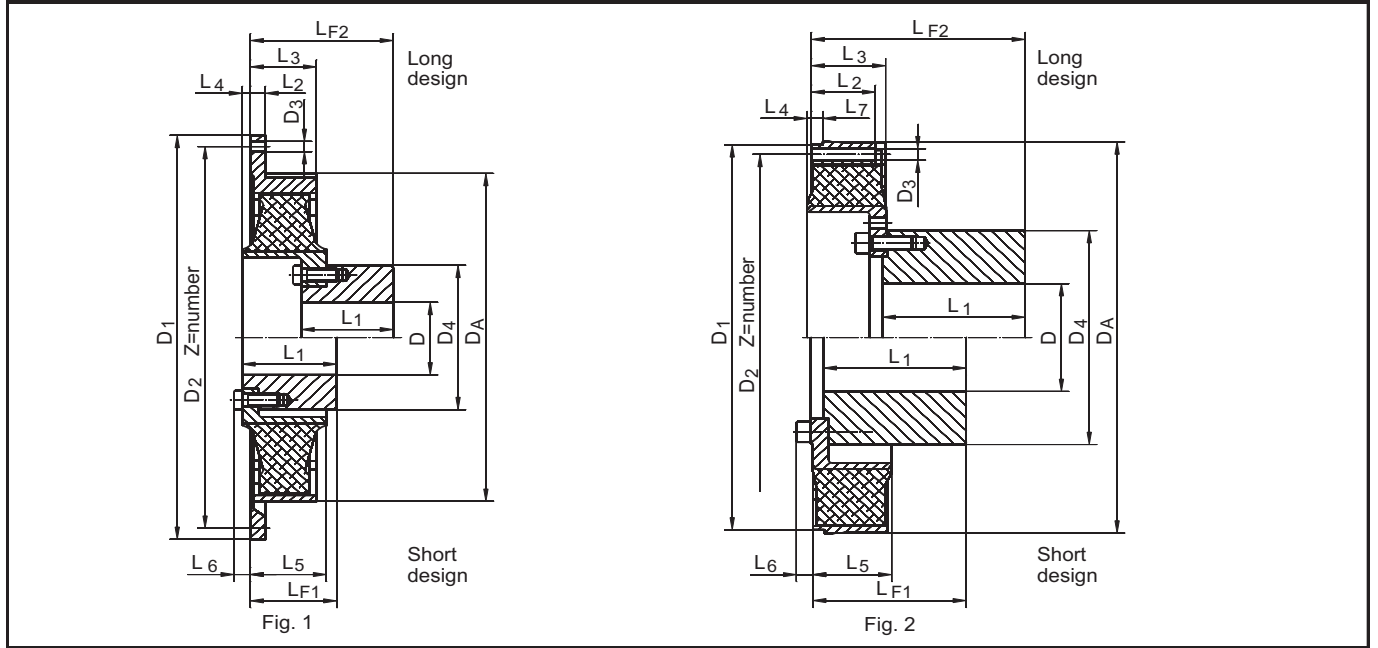

ARCUSAFLEX coupling size	Fig.	Flange connection SAE J 620						D _A	D		D ₄	L ₁	L ₂	L ₃	L ₄	L ₅	L ₆	L ₇	L _{F1} short	L _{F2} long	J ₁ outside [kgm²]	J ₂ inside [kgm²]	Total weight [kg]
		SAE size	D ₁	D ₂	D ₃	Z	min		max														
AC 2,3.*)F2	-	6.5	215.9	200.0	8.5	6	222	unbored, precentered	60	98	54	6	41	-	52	-	8	-	103	0.008	0.010	5.8	
	2	7.5	241.3	222.3	8.5	8	222		60	98	54	33	33	-	43	-	8	-	94	0.011	0.010	6.1	
	1	8	263.5	244.5	10.5	6	222		60	98	54	8	33	-	43	-	-	-	94	0.011	0.010	6.4	
	1	10	314.3	295.3	10.5	8	222		60	98	54	8	33	-	43	-	-	-	94	0.017	0.010	6.9	
AC 2,6.*)F2	2	8	263.5	244.5	10.5	6	263		65	118	65	33	38	3	42	11	10	73	104	0.011	0.022	6.6	
	1	10	314.3	295.3	10.5	8	263		65	118	65	10	38	3	42	11	-	73 ¹⁾	104	0.017	0.022	6.9	
	1	11.5	352.4	333.4	10.5	8	263		65	118	65	10	38	3	42	11	-	73	104	0.024	0.022	7.2	
AC 3.*)F2	1	10	314.3	295.3	10.5	8	290		65	118	68	16	52	6	59	13	-	73 ¹⁾	121	0.026	0.026	9.2	
	1	11.5	352.4	333.4	10.5	8	290		60	118	70	16	52	6	59	13	-	59 ¹⁾	107	0.036	0.027	10.3	
AC 4.*)F2	2	10	314.3	295.3	10.5	8	320		80	140	101	56	56	8	68	16	8	106	166	0.042	0.065	18.2	
	1	11.5	352.4	333.4	10.5	8	320		80	140	101	16	60	8	68	16	-	106 ¹⁾	166	0.062	0.065	18.9	
	1	14	466.7	438.2	13.0	8	320		80	140	87	16	60	8	68	16	-	92 ¹⁾	152	0.181	0.061	20.3	
AC 4,9.*)F2	1	11.5	352.4	333.4	10.5	8	320		90	160	100	16	77	-	79	7	-	106 ¹⁾	165	0.080	0.105	19.4	
	1	14	466.7	438.2	13.0	8	320		90	160	90	16	77	-	79	7	-	92 ¹⁾	151	0.125	0.105	20.5	
AC 5.*)F2	2	11.5	352.4	333.4	10.5	8	354		90	160	110	54	65	13	76	23	20	106 ¹⁾	175	0.065	0.134	24.7	
	1	14	466.7	438.2	13.0	8	354		90	160	105	15	65	13	76	23	-	92 ¹⁾	161	0.179	0.132	27.3	
AC 6.*)F2	1	14	466.7	438.2	13.0	8	420		100	185	102	18	80	10	92	20	-	92 ¹⁾	174	0.220	0.321	36.3	
	1	16	517.5	489.0	13.0	8	420		100	185	102	18	80	10	92	20	-	92	174	0.320	0.321	38.2	
	1	18	571.5	542.9	17.0	6	420		100	185	102	18	80	10	92	20	-	92	174	0.470	0.321	40.5	
AC 6,5.*)F2	1	14	466.7	438.2	13.0	8	420		120	222	125	16	90	-	92	35	-	92 ¹⁾	164	0.688	0.404	48.5	
	2	14	466.7	438.2	13.0	8	465		120	222	125	85	85	2	88	33	27	92 ¹⁾	164	0.312	0.578	55.8	
AC 7.*)F2	1	16	517.5	489.0	13.0	8	465		120	222	125	27	85	2	88	33	-	92	164	0.411	0.578	57.1	
	1	18	571.5	542.9	17.0	6	465		120	222	125	18	85	2	88	33	-	92	164	0.519	0.578	60.5	
AC 8.*)F2	1	18	571.5	542.9	17.0	12	514		165	250	142	18	84	0	86	10	-	159	225	0.478	0.925	55.3	
	1	21	673.1	641.4	17.0	12	514		165	250	142	18	84	0	86	10	-	159	255	0.948	0.925	60.1	
AC 9.*)F2	1	18	571.5	542.9	17.0	12	560		75	150	240	140	35	92	0	103	9	-	131	237	0.846	1.232	69.0
	1	21	673.1	641.4	17.0	12	560		75	150	240	140	20	92	0	103	9	-	131	237	1.422	1.232	78.4
AC 10.*)F2	2	18	571.5	542.9	17.0	12	580		90	200	316	200	104	104	0	107	23	15	215	300	0.770	2.365	109.0
	1	21	673.1	641.4	17.0	12	580		90	200	316	200	26	104	0	107	23	-	215	300	1.222	2.365	113.0
AC 11.*)F2	2	21	673.1	641.4	17.0	12	682		90	220	380	210	85	111	0	107	24	15	232	312	3.800	5.311	205.0
	1	24	733.4	692.2	21.0	12	682		90	220	380	210	20	111	0	107	24	-	232	312	5.286	5.311	214.0

*) For the element versions, see "Technical details"

1) Mounting lengths for flange connecting dimensions to SAE J 620 and/or DIN 6281

The option of mounting the coupling element internally or externally provides two different overall lengths with one and the same coupling hub.

Other flange and length dimensions on request.

ARCUSAFLEX flywheel couplings

Type AC-...F2K with bolted hub for radial element change

Flange connecting dimensions to SAE J 620 d

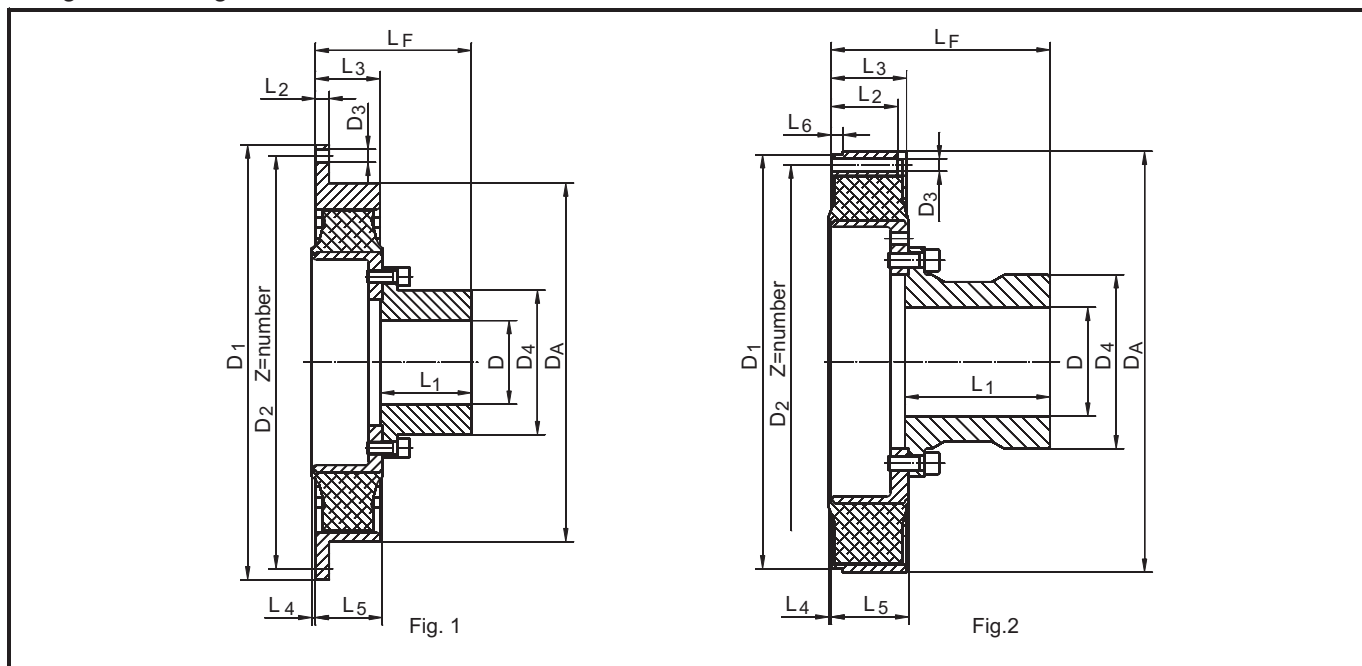

ARCUSAFLEX coupling size	Fig.	Flange connection SAE J 620						D min.	D max.	D ₄	L ₁	L ₂	L ₃	L ₄	L ₅	L ₆	L _F	J ₁ outside [kgm ²]	J ₂ inside [kgm ²]	Total weight [kg]
		SAE size	D ₁	D ₂	D ₃	Z	D _A													
AC 2,6*).F2K	2	8	263.5	244.5	10.5	6	263	unbored, precentered	55	78	65	33	38	3	42	10	104	0.011	0.017	5.0
	1	10	314.3	295.3	10.5	8	263		55	78	65	10	38	3	42	-	104	0.017	0.017	5.3
	1	11.5	352.4	333.4	10.5	8	263		55	78	65	10	38	3	42	-	104	0.024	0.017	5.6
AC 3*).F2K	-	10	314.3	295.3	10.5	8	290		55	78	65	16	52	6	59	-	121	0.026	0.027	8.1
	-	11.5	352.4	333.4	10.5	8	290		55	78	65	16	52	6	59	-	121	0.036	0.027	8.4
AC 4.1*).F2K	2	10	314.3	295.3	10.5	8	320		75	112	95	56	56	-	59	8	152	0.042	0.064	11.2
	1	11.5	352.4	333.4	10.5	8	320		75	112	95	16	60	-	59	-	152	0.062	0.064	11.9
	1	14	466.7	438.2	13.0	8	320		75	112	95	16	60	-	59	-	152	0.181	0.064	14.7
AC 4,9*).F2K	1	11.5	352.4	333.4	10.5	8	320		85	127	95	16	77	-	79	-	172	0.080	0.085	15.8
	1	14	466.7	438.2	13.0	8	320		85	127	95	16	77	-	79	-	172	0.125	0.085	16.9
AC 5.1*).F2K	2	11.5	352.4	333.4	10.5	8	354		85	127	95	54	65	-	68	20	161	0.065	0.107	16.0
	1	14	466.7	438.2	13.0	8	354		85	127	95	15	65	-	68	-	161	0.179	0.107	18.7
AC 6.1*).F2K	1	14	466.7	438.2	13.0	8	420		110	165	95	18	80	-	82	-	174	0.220	0.243	25.1
	1	16	517.5	489.0	13.0	8	420		110	165	95	18	80	-	82	-	174	0.320	0.243	27.0
	1	18	571.5	542.9	17.0	6	420		110	165	95	18	80	-	82	-	174	0.470	0.243	29.1
AC 6,5*).F2K	1	14	466.7	438.2	13.0	8	420		130	190	119	18	90	-	92	-	209	0.688	0.542	46.5
AC 7*).F2K	2	14	466.7	438.2	13.0	8	465		130	190	119	85	85	2	88	27	204	0.312	0.542	40.5
	1	16	517.5	489.0	13.0	8	465		130	190	119	27	85	2	88	-	204	0.411	0.542	41.9
	1	18	571.5	542.9	17.0	6	465	130	190	119	18	85	2	88	-	204	0.519	0.542	45.2	
AC 8*).F2K	1	18	571.5	542.9	17.0	12	514	155	227	162	18	84	0	86	-	245	0.478	0.942	59.1	
	1	21	673.1	641.4	17.0	12	514	155	227	162	18	84	0	86	-	245	0.948	0.942	63.9	
AC 9*).F2K	1	18	571.5	542.9	17.0	12	560	75	165	240	140	35	92	0	103	-	237	0.846	1.232	67.5
	1	21	673.1	641.4	17.0	12	560	75	165	240	140	20	92	0	103	-	237	1.422	1.232	78.4
AC 10*).F2K	2	18	571.5	542.9	17.0	12	580	90	165	240	200	104	104	0	107	15	302	0.770	1.652	80.0
	1	21	673.1	641.4	17.0	12	580	90	165	240	200	26	104	0	107	-	302	1.222	1.652	84.0
AC 11*).F2K	2	21	673.1	641.4	17.0	12	682	90	200	300	210	85	111	0	107	15	312	3.800	3.623	154.0
	1	24	733.4	692.2	21.0	12	682	90	200	300	210	20	111	0	107	-	312	5.286	3.623	164.0
AC 12*).F2K	1	-	860.0	820.0	20.0	32	780	90	260	390	255	26	135	0	137	-	389	10.700	12.040	329.0
	1	-	920.0	880.0	20.0	32	870	90	260	390	255	27	136	0	137	-	389	15.400	12.040	352.0
	1	-	995.0	950.0	22.0	32	870	90	260	390	255	27	136	0	137	-	389	20.500	12.040	374.0

*) For the element versions, see "Technical details"

Other flange and length dimensions on request.

Ordering example: Coupling designation: **AC 9. NN. F2K. 18. 237**
 ARCUSAFLEX coupling size
 Element version acc. to "Technical details"
 Version for the element change
 Size of flange connection to SAE J 620 (AC12: D₁)
 Mounting length L_F in mm

ARCUSAFLEX shaft couplings

Type AC-T...T and type AC...TK

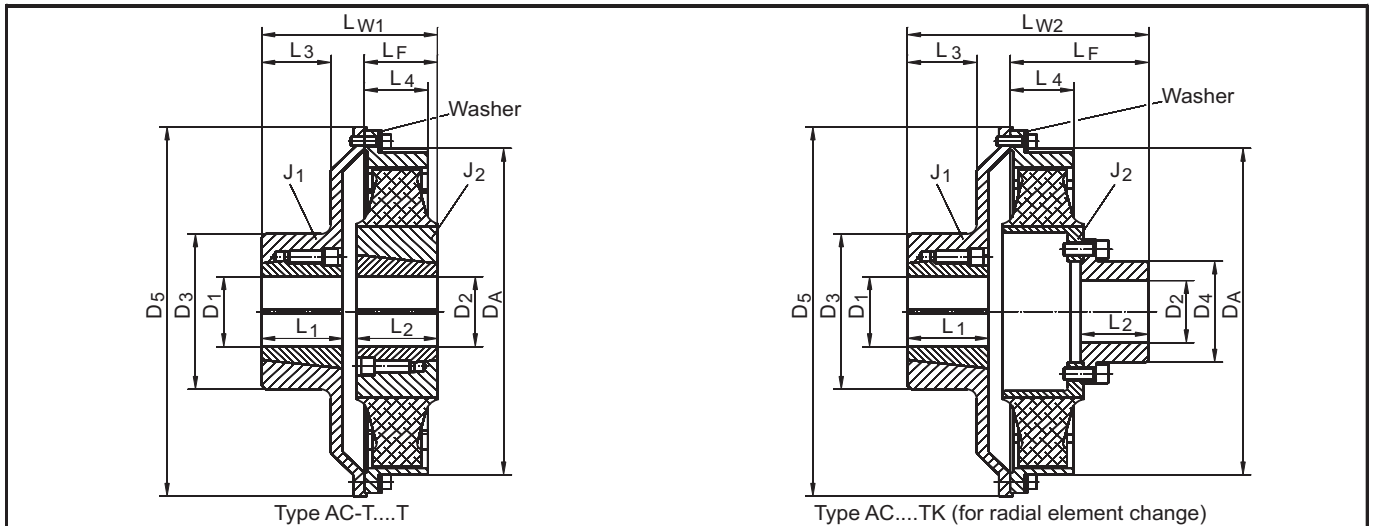

ARCUSAFLEX coupling size	Taper bush		Taper bush		D ₃	D ₄	D ₅	D _A	L ₁	L ₂	L ₃	L ₄	L _F	L _{w1}	L _{w2}	J ₁ [kgm ²]	J ₂ [kgm ²]	Total weight [kg]
	No.	D ₁ max.	No.	D ₂ max.														
AC-T 2,3...T	2012	48	2012	48	102	-	225	222	32	32	23	41	52	84	-	0.026	0.008	7.4
AC-T 2,6...T	2517	60	2517	60	105	-	325	263	45	45	42	38	42	115	-	0.121	0.019	15.9
AC-T 3...T	2517	60	2517	60	105	-	325	290	45	45	42	52	58	131	-	0.133	0.026	18.2
AC 3...TK	2517	60	-	55	105	78	325	290	45	65	42	52	121	-	194	0.133	0.027	17.8
AC-T 4...T	3030	75	3030	75	140	-	360	320	76	76	64	60	68	166	-	0.229	0.059	29.4
AC 4.1...TK	3030	75	-	75	140	112	360	320	76	95	64	60	152	-	250	0.229	0.064	27.2
AC-T 4,9...T	3535	90	3535	90	170	-	360	320	89	89	74	77	92	209	-	0.290	0.097	37.8
AC 4,9...TK	3535	90	-	85	170	127	360	320	89	95	74	77	172	-	289	0.290	0.085	36.8
AC-T 5...T	3535	90	3535	90	170	-	360	354	89	89	74	65	76	193	-	0.275	0.131	42.4
AC 5.1...TK	3535	90	-	85	170	127	360	354	89	95	74	65	161	-	278	0.275	0.107	37.0
AC-T 6...T	4545	110	4040	100	220	-	475	420	115	102	98	80	92	221	-	0.957	0.334	80.8
AC 6.1...TK	4545	110	-	110	220	165	475	420	115	95	98	80	174	-	308	0.957	0.243	68.9
AC-T 6,5...T	4545	110	4535	110	220	-	475	420	115	90	98	90	92	226	-	1.425	0.432	96.4
AC 6,5...TK	4545	110	-	-	220	190	475	420	115	95	98	90	209	-	343	1.425	0.542	90.3
AC-T 7...T	4545	110	4535	110	220	-	475	465	115	90	98	85	87	221	-	1.049	0.696	97.5
AC 7...TK 4545	4545	110	-	130	220	190	475	465	115	119	98	85	204	-	338	1.049	0.542	80.7

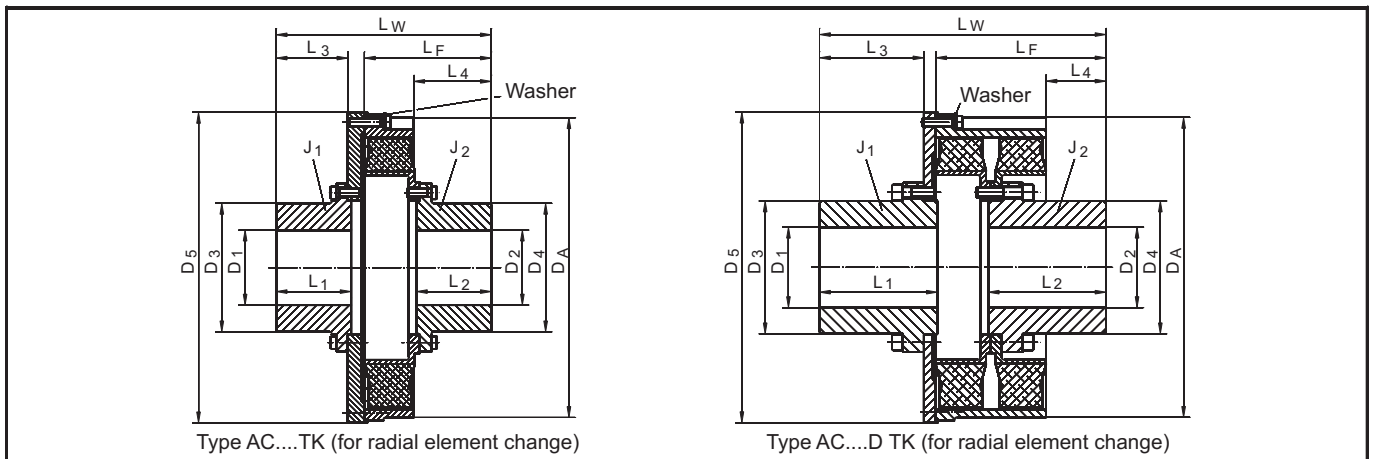

ARCUSAFLEX coupling size	D ₁ max.	D ₂ max.	D ₃	D ₄	D ₅	D _A	L ₁	L ₂	L ₃	L ₄	L _F	L _w	J ₁ [kgm ²]	J ₂ [kgm ²]	Total weight [kg]
AC 7 ... TK	130	130	190	190	475	465	119	119	117	119	204	346	1.335	0.558	95.7
AC 8 ... TK	150	150	230	230	580	514	162	162	159	166	245	437	2.567	0.950	133.0
AC 8D ... TK	150	150	230	230	580	525	226	226	201	142	314	543	3.349	1.767	198.0
AC 9 ... TK	150	150	240	240	580	560	140	140	134	145	237	393	3.300	1.232	140.0
AC 9D ... TK	160	160	248	248	580	560	220	220	195	113	318	535	4.660	2.515	235.0
AC 10 ... TK	160	160	240	240	600	580	200	200	195	202	306	531	3.465	1.652	167.0
AC 11 ... TK	200	200	300	300	682	682	210	210	205	209	320	562	10.370	3.623	296.0
AC 12 ... TK	260	260	390	390	870	772	255	255	252	259	389	667	27.200	12.040	498.0

Other sizes and types on request / For the element versions, see "Technical details"

ARCUSAFLEX flywheel couplings

with 2 elements operating in tandem

Type AC...D.F2 with bolted hub and flange connecting dimensions to SAE J 620 d

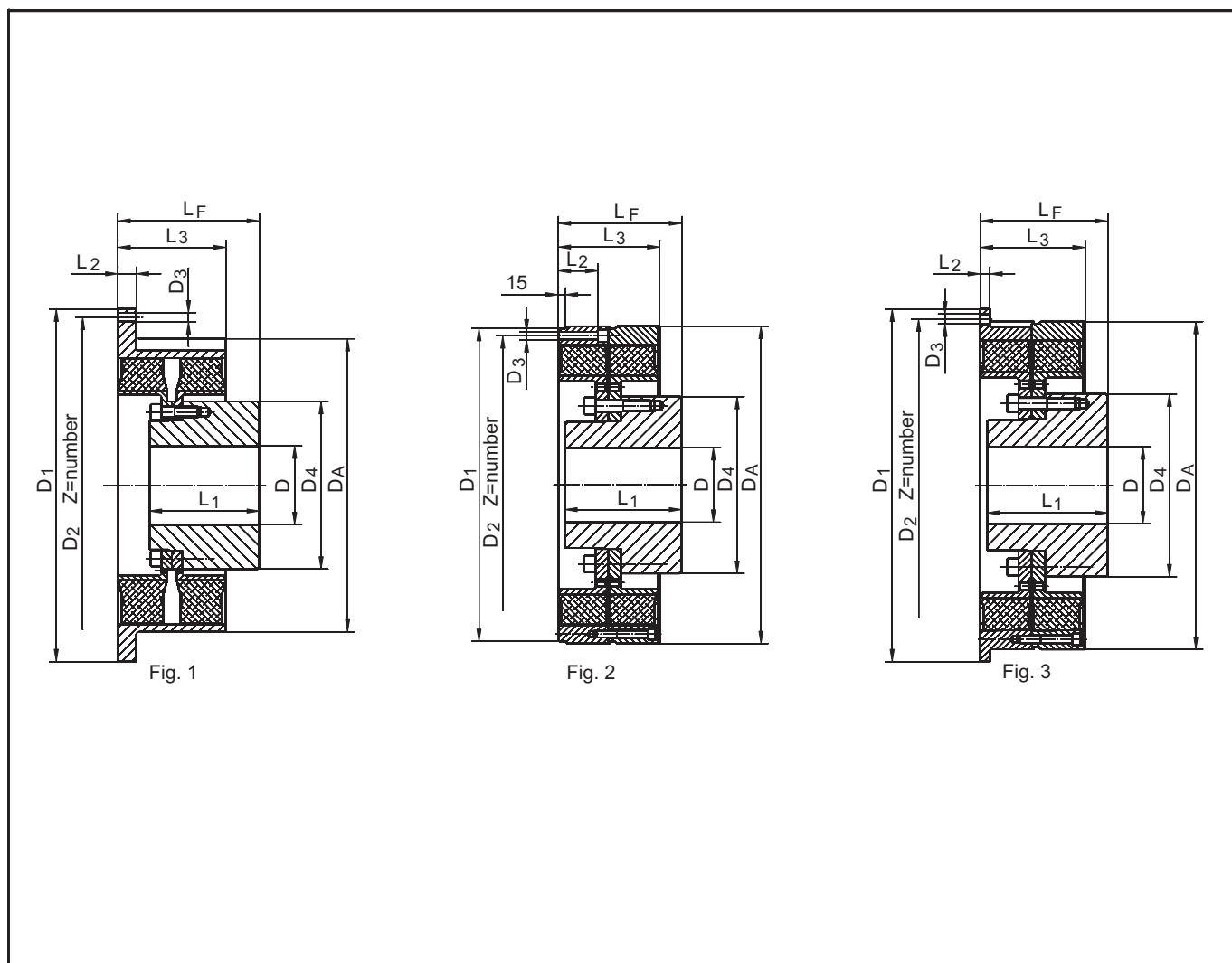

ARCUSAFLEX coupling size	Fig.	Flange connection SAE J 620						D _A	D		D ₄	L ₁	L ₂	L ₃	L _F	J ₁ outside [kgm ²]	J ₂ inside [kgm ²]	Total weight [kg]
		SAE size	D ₁	D ₂	D ₃	Z	min.		max.									
AC 8D.*)F2	1	18	571.5	542.9	17.0	12	525	-	165	250	174	25	172	255	1.007	1.554	85.4	
	1	21	673.1	641.4	17.0	12	525	-	165	250	174	18	172	255	1.477	1.554	90.2	
AC 9D.*)F2	1	18	571.5	542.9	17.0	12	560	75	170	316	210	35	205	270	1.660	2.801	140.6	
	1	21	673.1	641.4	17.0	12	560	75	170	316	210	25	205	270	2.168	2.801	146.5	
AC 10D.*)F2	1	24	733.4	692.2	21.0	12	560	75	170	316	210	35	205	270	3.375	2.801	151.2	
	1	21	673.1	641.4	17.0	24	585	90	200	316	250	26	210	350	1.996	3.840	168.0	
AC 11D.*)F2	1	24	733.4	692.2	21.0	12	585	90	200	316	250	26	210	350	2.575	3.840	173.0	
	2	21	673.1	641.4	17.0	12	682	90	220	380	250	85	218	265	7.600	6.966	266.0	
AC 11D.*)F2	3	24	733.4	692.2	21.0	12	682	90	220	380	250	20	218	265	9.086	6.966	275.0	

*)For the element versions, see "Technical details"

Other flange and length dimensions on request.

Ordering example: Coupling designation: **AC 9D. NN.F2. 18. 270**
 ARCUSAFLEX coupling size
 Element version acc. to "Technical details"
 Size of flange connection to SAE J 620
 Mounting length L_F in mm

ARCUSAFLEX flywheel couplings

with 2 elements operating in tandem

Type AC...D.F2K with bolted hub for radial element change and flange connecting dimensions to SAE J 620 d

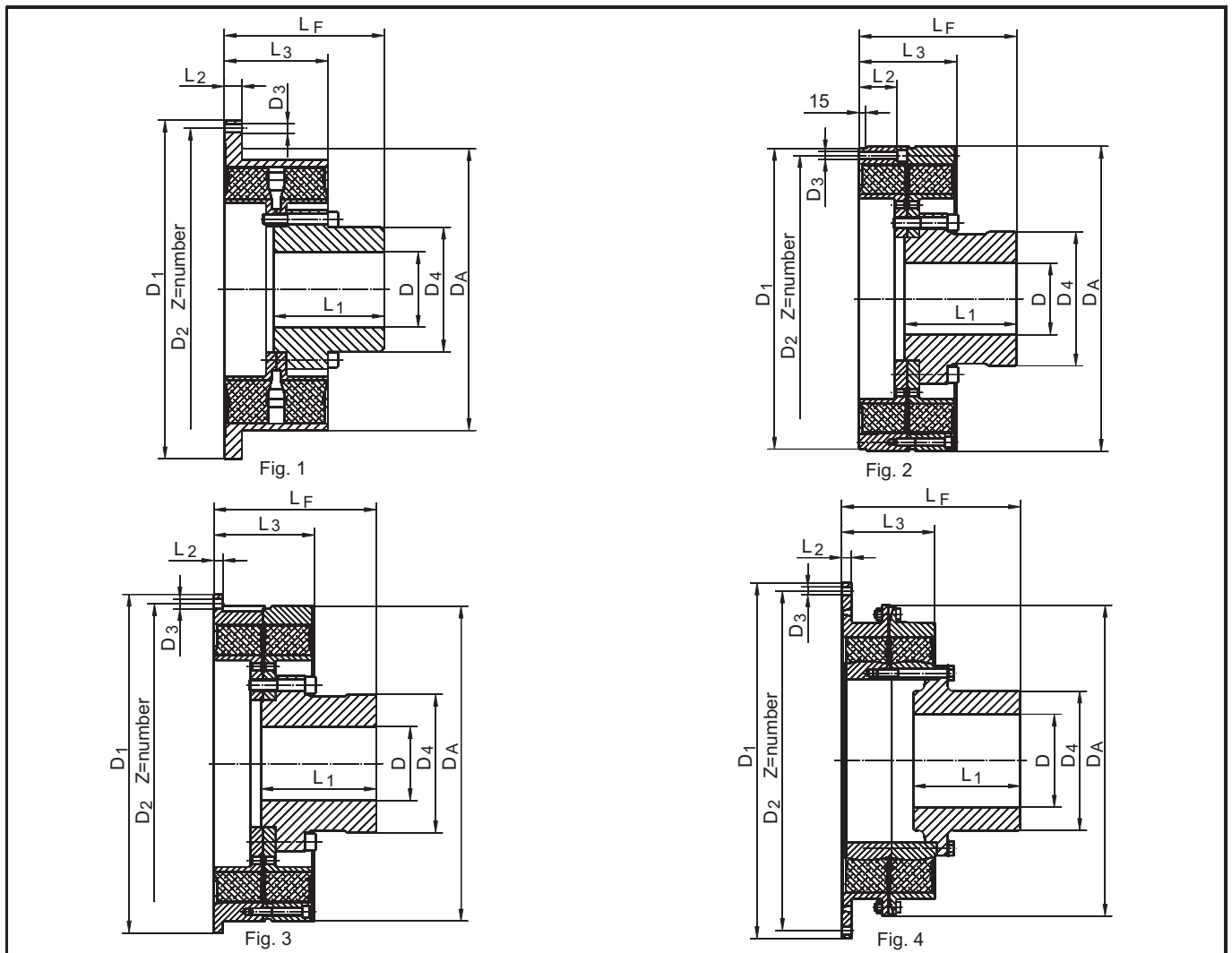

ARCUSAFLEX coupling size	Fig.	Flange connection SAE J 620						D _A	D		D ₄	L ₁	L ₂	L ₃	L _F	J ₁ outside [kgm ²]	J ₂ inside [kgm ²]	Total weight [kg]
		SAE size	D ₁	D ₂	D ₃	Z	min.		max.									
AC 8D.*)F2K	1	18	571.5	542.9	17.0	12	525	-	150	227	226	25	172	307	1.007	1.780	104.0	
	1	21	673.1	641.4	17.0	12	525	-	150	227	226	18	172	307	1.477	1.780	109.0	
AC 9D.*)F2K	1	18	571.5	542.9	17.0	12	560	75	160	248	220	35	205	318	1.660	2.515	131.0	
	1	21	673.1	641.4	17.0	12	560	75	160	248	220	25	205	318	2.168	2.515	135.5	
	1	24	733.4	692.2	21.0	12	560	75	160	248	220	35	205	318	3.375	2.515	145.0	
AC 10D.*)F2K	1	21	673.1	641.4	17.0	24	585	90	160	240	250	26	210	350	1.996	3.176	146.0	
	1	24	733.4	692.2	21.0	12	585	90	160	240	250	26	210	350	2.575	3.176	151.0	
AC 11D.*)F2K	2	21	673.1	641.4	17.0	12	682	90	200	300	250	85	218	352	7.600	6.516	260.0	
	3	24	733.4	692.2	21.0	12	682	90	200	300	250	20	218	352	9.086	6.516	270.0	
AC 12D.*)F2K	4	-	860.0	820.0	21.0	32	870	90	260	390	300	19	258	496	22.300	20.000	540.0	
	4	-	920.0	880.0	20.0	32	870	90	260	390	300	27	266	500	26.200	20.000	555.0	
	4	-	995.0	950.0	22.0	32	870	90	260	390	300	27	266	500	31.200	20.000	601.0	

*) For the element versions, see "Technical details"
Other flange and length dimensions on request.

Ordering example: Coupling designation: **AC 10D. NN. F2K. 21. 350**
 ARCUSAFLEX coupling size
 Element version acc. to "Technical details"
 Version for the element change
 Size of flange connection to SAE J 620 (AC12D: D₁)
 Mounting length L_F in mm

Mounting instruction for ARCUSAFLEX flywheel couplings Type AC-T...F2 with taper bush

How to mount the taper bush

1. The outer taper of the taper bush and the bore with the inner taper of the element hub shall show bright metal and must be free of grease prior to mounting. Preservatives must be removed completely.
2. Insert the taper bush into the element hub and line up all connecting bores. Make sure that half threaded holes coincide with half plain holes (Fig. 1).
3. Screw in lightly greased or oiled assembly screws. Do not tighten the screws yet (Fig. 2).
4. Slide the element hub with inserted taper bush onto the cleaned shaft with keyway and put it into the mounting position L_x (Fig. 3).
5. Tighten the screws uniformly up to the tightening torque M_{A1} specified in table 1 using a torque wrench.
6. The screws can be retightened again by tapping against the taper bush with a hammer using an intermediate plate. Repeat, if necessary.

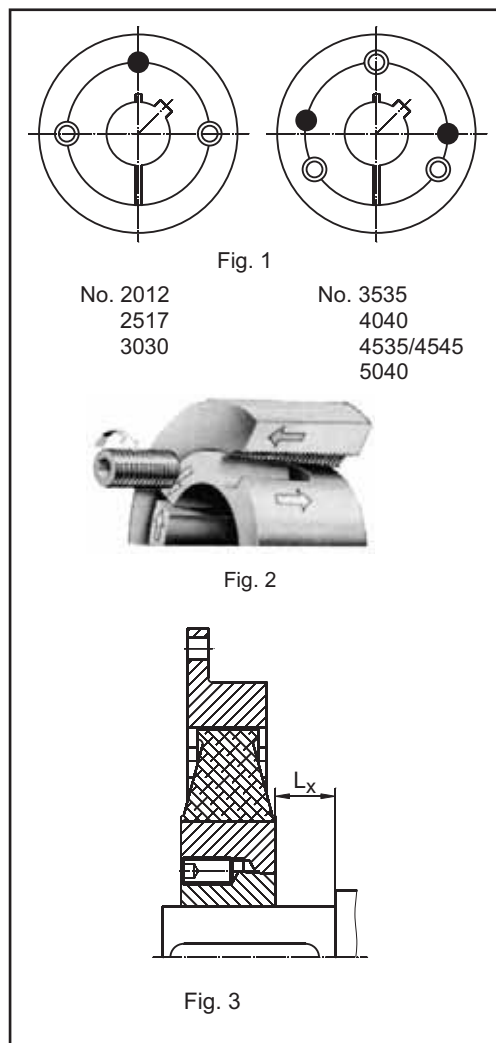

Tightening torques for mounting the taper bush

Table 1

Coupling size	AC-T 2,3	AC-T 2,6 AC-T 3	AC-T 4	AC-T4,9 AC-T 5	AC-T 6	AC-T 6,5 AC-T 7	AC-T 8 AC-T 9
Taper bush No.	2012	2517	3030	3535	4040	4535 4545	5040
B.S.W. screw size *)	$\frac{7}{16} \times 22$	$\frac{1}{2} \times 25$	$\frac{5}{8} \times 32$	$\frac{1}{2} \times 38$	$\frac{5}{8} \times 45$	$\frac{3}{4} \times 50$	$\frac{7}{8} \times 57$
Tightening torque M_{A1} [Nm]	31	49	92	115	172	195	271
Width across flats SW [mm]	6	6	8	10	12	14	14

*) Nr.2012/2517/3030 set screw
Nr.3535/4040/4535/4545/5040 cap screw

How to remove the element hub with taper bush

1. Loosen and remove all screws. Depending on the taper bush size, screw either 1 or 2 greased screws into the half pulling-off thread(s) of the taper bush (Fig. 4).
2. Tighten the screws uniformly until the taper bush is loose in the element hub.
3. As soon as the taper bush is loose, the element hub can be pulled off the shaft together with the taper bush.

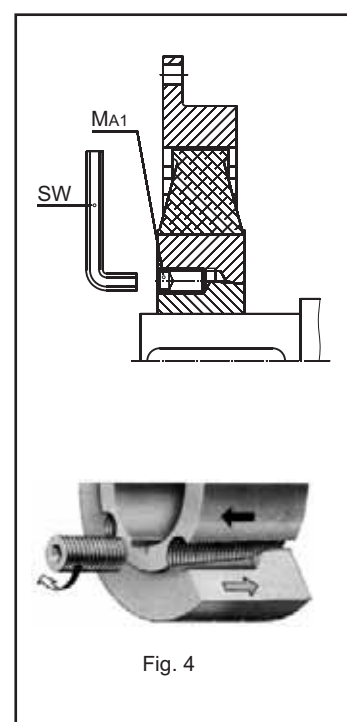

Tightening torques for ARCUSAFLEX flywheel couplings

All bolts and screws must be tightened to the specified torques during assembly in order to ensure a reliable torque transmission. Prior to putting the machinery into operation, all bolts and screws of the coupling must be checked for proper fit and tightness. The indicated torques apply to an total friction factor of $\mu = 0.14$. For further questions please ask REICH-KUPPLUNGEN.

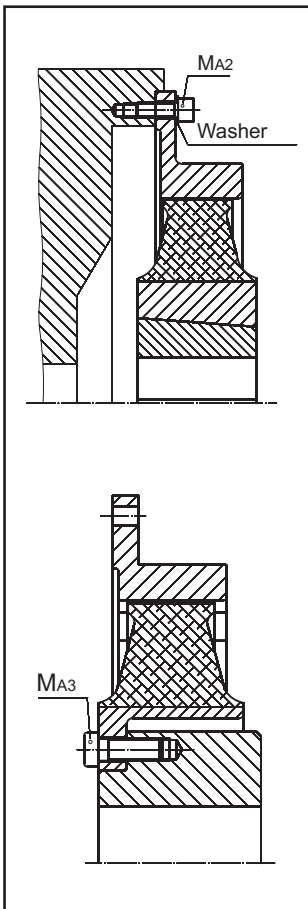

Table 2

Tightening torques for the bolted flange connection to the engine flywheel (grade 8.8)

SAE flywheel flange	6 1/2	7 1/2	8	10	11 1/2	14	16	18	21	24
Metric bolts	M8		M10			M12		M16		M20
Tightening torque M_{A2} [Nm]	25		50			85		210		420
Imperial size bolts	5/16 - 18		3/8 - 16			1/2 - 13		5/8 - 11		3/4 - 10
Tightening torque M_{A2} [Nm]	24		42			102		203		340

Note: The aluminium flanges of the coupling sizes AC 2,3 - AC 10D have to be mounted **only with washers**. We recommend to use washers as big as possible, but minimum dimensions according to DIN 433. If needed bolts of grade 10.9 with suitable washers and the corresponding tightening torque can be used, please consult us.

Table 3

Tightening torques for the bolted hub connection
Types AC...F2 and AC...F2.K (grade 8.8)

Coupling size	AC 2,3	AC 2,6 AC 3 AC 4/4.1	AC 4,9 AC 5/5.1	AC 6/6.1 AC 6,5	AC 7 AC 8 / AC 8D AC 9 / AC 9D	AC 10 / AC 10D AC 11 / AC 11D AC 12	AC 12D		
Bolt size (metric)	M8	M12	M16	M16	M16	M20	M20	M24	M24(10.9)
Tightening torque M_{A3} [Nm]	25	85	210	210	210	420	420	710	1000

ARCUSAFLEX shaft couplings

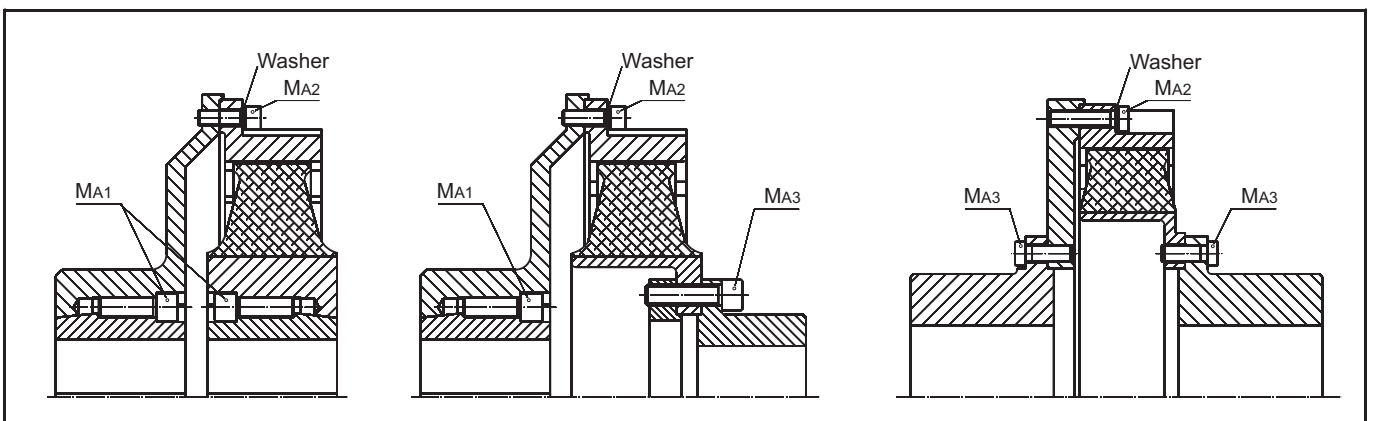

Coupling size	AC 2,3	AC 2,6 AC 3 AC 4 / 4.1	AC 4,9 AC 5 / 5.1	AC 6 / 6.1 AC 6,5 AC 7	AC 8 / AC 8D AC 9 / AC9D	AC 10 AC 11 AC12		
Bolt size (metric)	M8	M10	M10	M12	M16	M20	M20	M24
Tightening torque M_{A2} [Nm]	25	50	50	85	210	420	420	710

For the tightening torques M_{A1} see the mounting instruction for taper bushes table 1.
For the tightening torques M_{A3} see table 3.

Alignment

Careful alignment of the coupling is an essential requirement for detached, non-flanged machinery in order to ensure proper functioning of the coupling and to avoid premature wear of the rubber element.

Flywheel couplings shall be aligned from the shaft-side coupling half to either one of the machined surfaces of the engine flywheel or engine housing. Where shaft couplings are used, the angular and radial displacements between the two coupling halves are determined by applying the usual dial indicator method. The alignment requirements of the other application components have to be considered additionally.

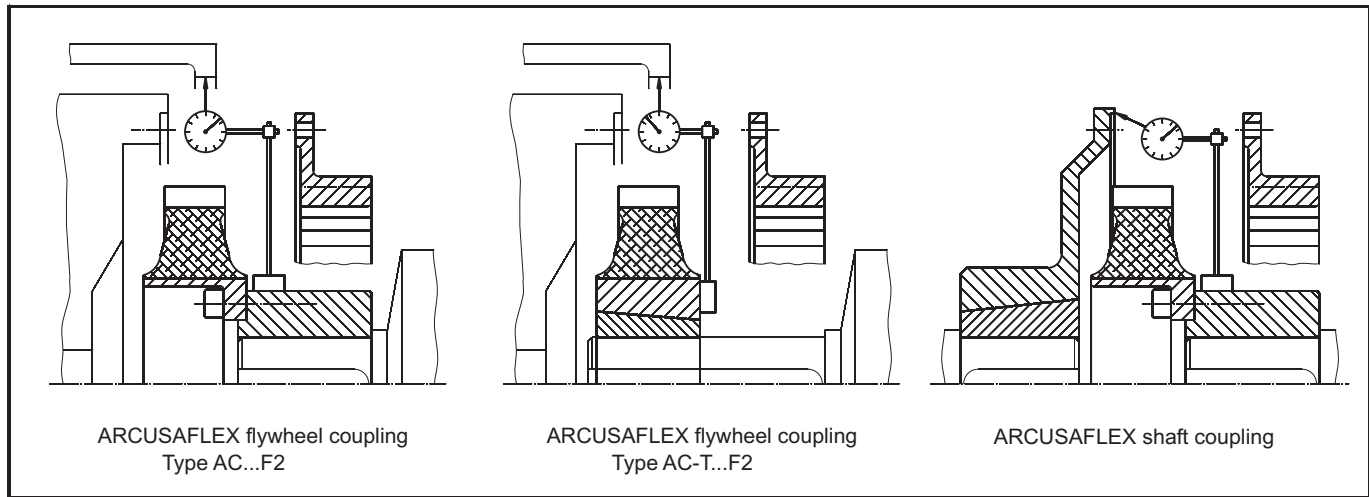

Permissible shaft displacement

The permissibility of major shaft displacements depends on a number of factors such as coupling size, shore hardness of the rubber element, operating speed and torque load of the coupling. The following reference values refer to an operating speed of ≈ 1500 rpm.

Precise alignment prevents premature wear of the rubber element.

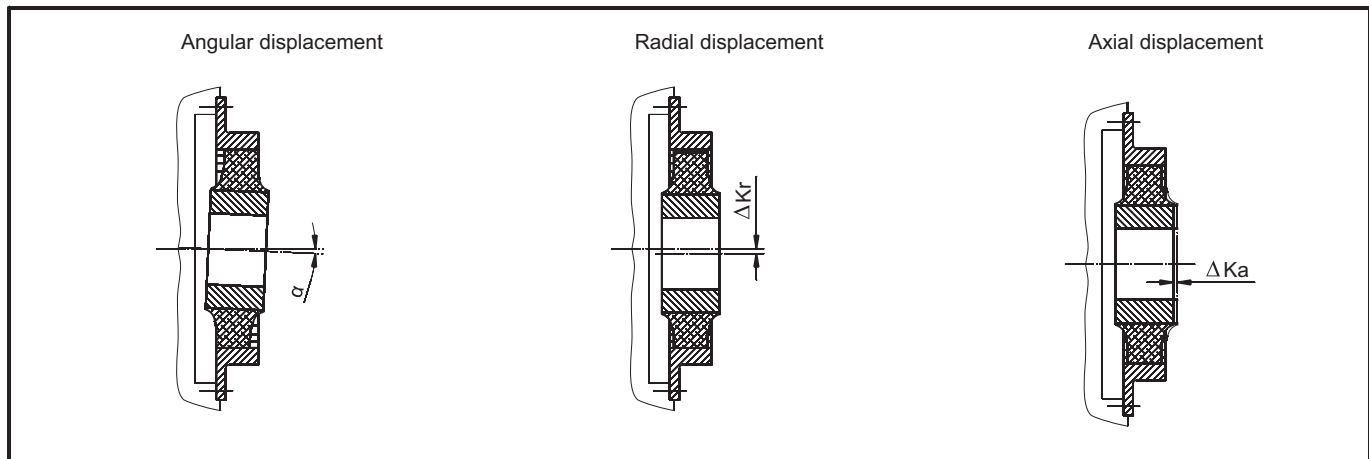

ARCUSAFLEX-coupling size	2,3	2,6	3	4 4.1	4,9	5 5.1	6 6.1	6,5	7	8 8D	9 9D	10 10D	11 11D	12 12D
Permissible radial displacement ΔKr [mm]	1.2	1.2	1.2	1.2	1.2	1.2	1.3	1.3	1.3	1.4	1.5	1.5	1.5	1.5
Permissible angular displacement α [°]	0.5°	0.5°	0.5°	0.5°	0.5°	0.5°	0.4°	0.4°	0.4°	0.4°	0.4°	0.3°	0.3°	0.3°
Permissible axial displacement ΔKa [mm]*	± 3	± 4	± 7	± 6	± 7	± 5	± 7	± 4	± 10	± 7	± 4	± 3	± 4	± 3

Larger displacements of short duration, as may occur when starting and stopping the diesel engine, are permissible. These maximum displacements must not occur simultaneously.

*) At types AC...F2K and AC...TK the axial fitting length L_F of the coupling should always offer a plus tolerance within the possible tolerance range in order to reach max. axial movability of the dismantled coupling element.

Safety precautions

It is the customer's and user's responsibility to provide proper guards over rotating machinery and to observe the national and international safety rules and laws. Check all bolted connections for proper fit preferably after the test run.

Requested Data Coupling Selection / Torsional Vibration Calculation

acc. to the 2-mass-system (DIN 740 part 2)

The dimensioning of the coupling should be supported by a torsional vibration analysis particularly with a view to the acting fatigue torque under reversing stresses. We are able to conduct this analysis according to the 2 or n-mass system when all required technical details are given.

ENGINE-SIDE:

1. Engine type
2. Engine power
3. Engine speed
4. In-line / V-engine
5. Number of cylinder
6. Total displacement
7. Moments of inertia (engine + flywheel)
8. Harmonic components of tangential effort
9. Necessary rules needed for the selection of the coupling
10. Drawing of the housing/flywheel with marking of their positions

P [kW]	
n [r.p.m.]	
R / V (angle)	
z	
V _H [ccm]	
J [kgm ²]	

DRIVEN-SIDE:

1. Kind of application (alternator, pump, compressor, etc.)
2. Type
3. Moments of inertia
4. Shaft diameter
5. Shaft length
6. Drawing of the driven machine

J [kgm ²]	
d [mm]	
l [mm]	

If the driven machine shall be flanged to the engine using an intermediate housing we kindly ask you to advise us the dimensions and details indicated on the following diagram enabling us to optimize the mounting position of the coupling.

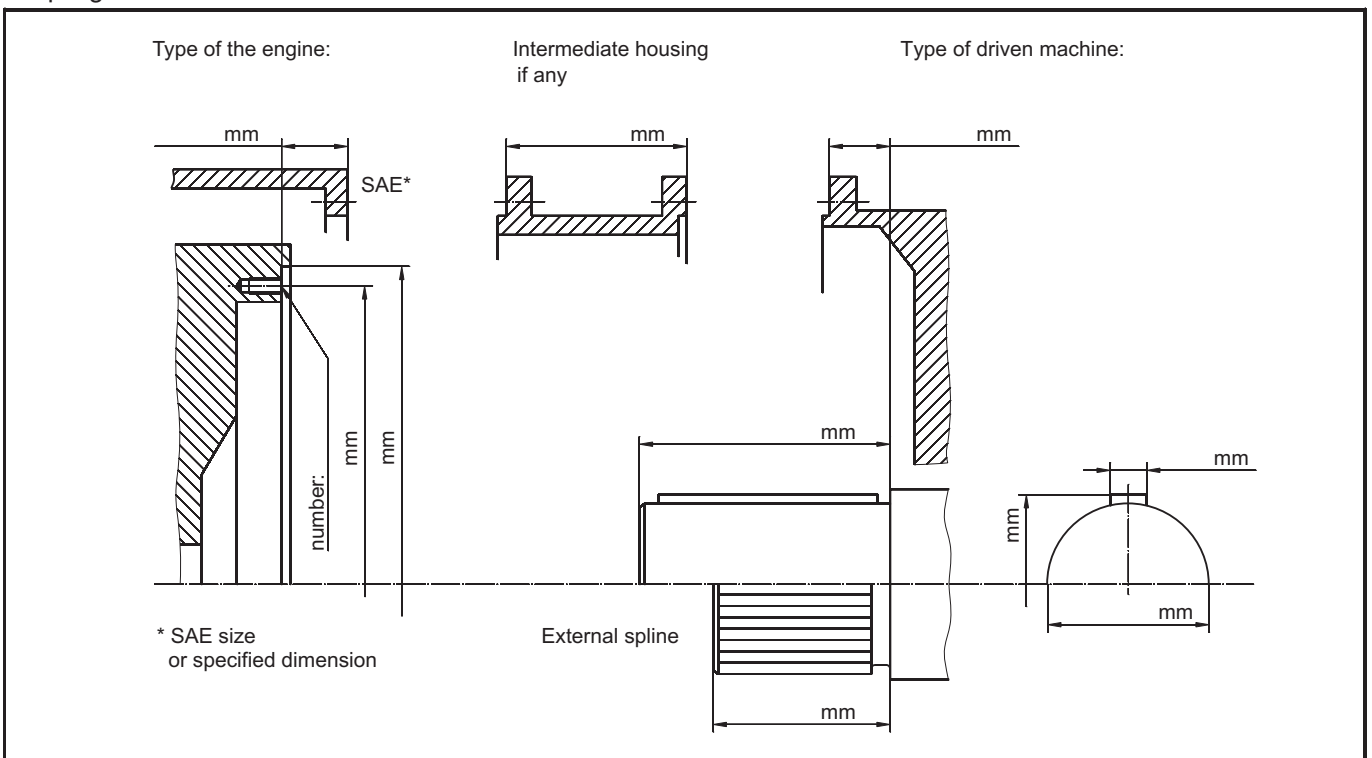

The coupling should always be properly ventilated in the intermediate housing (e.g. through ventilation holes in the housing).



**Maschinenfabrik
Dipl.-Ing. Herwarth Reich GmbH**

P.O.Box 10 20 66
D-44720 Bochum
Vierhausstr. 53
D-44807 Bochum
Phone: +49 2 34 9 59 16 0
Fax: +49 2 34 9 59 16 16
E-Mail: mail@reich-kupplungen.de
Internet: www.reich-kupplungen.de

REICH-KUPPLUNGEN • REICH-KUPPLUNGEN • REICH-KUPPLUNGEN • REICH-KUPPLUNGEN • REICH-KUPPLUNGEN

