

bondura® Multi Tool 140
pin and conical sleeve removal
Ø140mm - Ø195mm

bondura®

user manual - for disassembly

art. 103806 rev. 16.03.2016 A

- 1/ bondura® 6.6**
 - 1.1 conical sleeve removal / demontering av konhylse
 - 1.2 pin removal / demontering av pin
- 2/ bondura® 6.1**
 - 2.1 conical sleeve removal / demontering av konhylse
 - 2.2 pin removal / demontering av pin
- 3/ bondura® 6.2**
 - 3.1 conical sleeve removal / demontering av konhylse
 - 3.2 pin removal / demontering av pin
- 4/ additional / tillegg**
 - 4.1 Ø70mm - Ø135mm

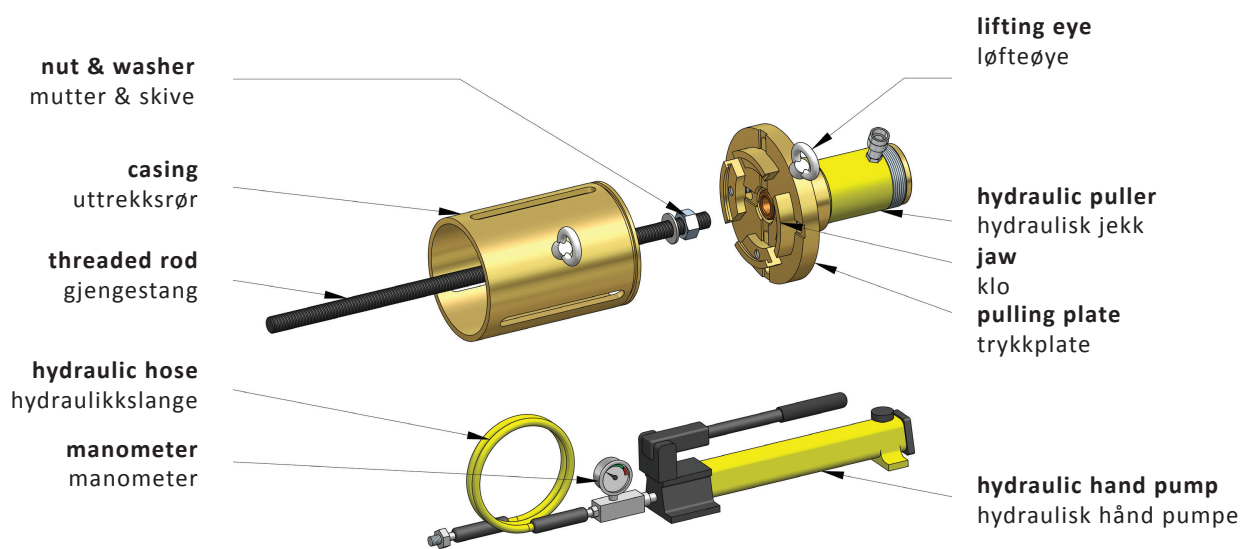

1/ bondura® 6.6

1.1 conical sleeve removal / demontering av konhylse

1.1.1/  To make it as easy as possible to disassemble, the equipment must be offloaded.

 For å gjøre demonteringen enklest mulig, må utstyret avlastes.

1.1.2/  Remove screws and plates.

 Demonter skruer og plater.

1.1.3/  The hydraulic puller is fitted to the pulling plate with the piston pointed towards the pin.

 Jekken monteres til trykkplaten med stampelet pekende mot pin.

1.1.4/  Assemble the tool as shown. The jaws should be fixed to the flange on the conical sleeve. Connect the hydraulic pump and hose. Pull out the conical sleeve.

 Monter verktøyet som vist. Avtrekksklørne skal skyves inn bak avtrekksflensen på konhylsen. Koble til hydraulisk pumpe og slange. Trekk ut konhylse.

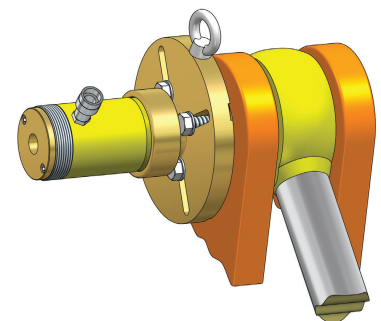
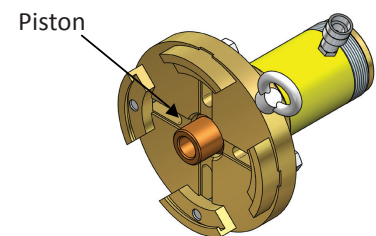
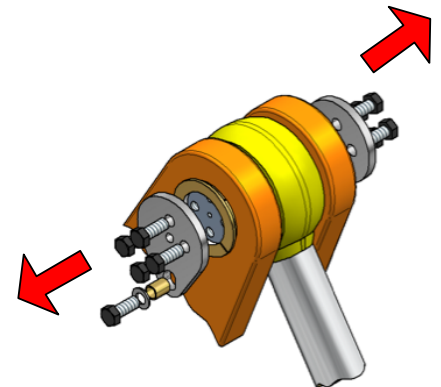



1/ bondura® 6.6

1.2 pin removal / demontering av pin

1.2.1/  The hydraulic puller is fitted to the pulling plate with piston pointed away from the pin.

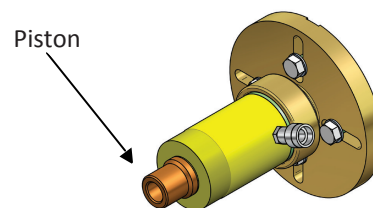
 Jekken monteres til trykkplaten med stempelet pekende fra pin.



1.2.2/  Attach the threaded rod to the pin's center hole, and assemble the tool as shown. Connect the hydraulic pump and hose. Pull out the pin.

 Fest gjengestangen i senterhullet på pin, og monter verktøyet som vist. Koble til hydraulisk pumpe og slange. Trekk ut pin.

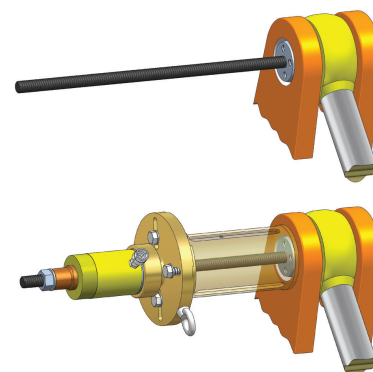

2/ bondura® 6.1

2.1 conical sleeve removal / demontering av konhylse

2.1.1/  To make it as easy as possible to disassemble, the equipment must be offloaded.

 For å gjøre demonteringen enklest mulig, må utstyret avlastes.

2.1.2/  Remove screws and plate.

 Demonter skruer og plate.

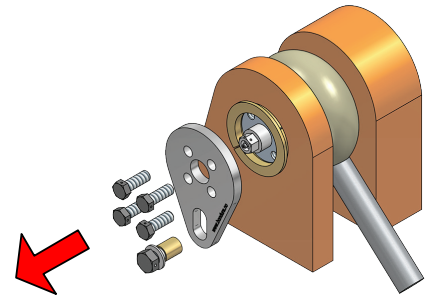

2.1.3/  Loosen the axle.

 Løsne akslingen.

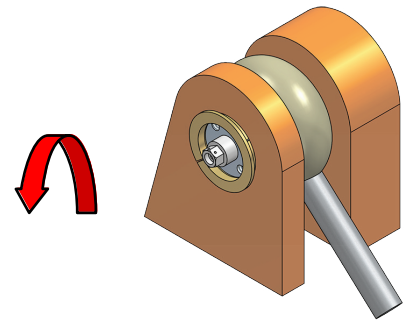

2.1.4/  Use a rubber mallet and hit on the axle to loosen the inner conical sleeve. Remove the axle.

 Bruk en gummi-klubbe og slå på akslingen for å løsne den indre konhylsen. Ta akslingen helt ut.

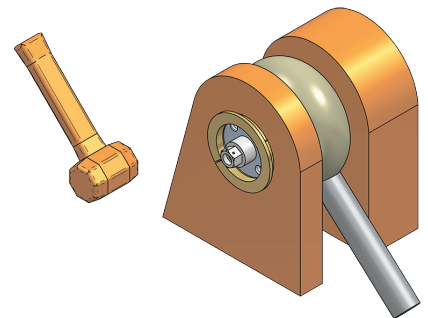

2.1.5/  The hydraulic puller is fitted to the pulling plate with the piston pointed towards the pin.

 Jekken monteres til trykkplaten med stempelet pekende mot pin.

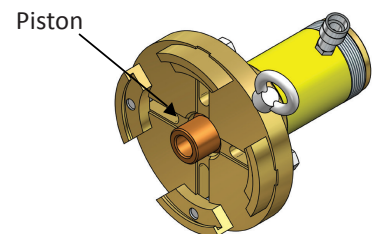

2.1.6/  Assemble the tool as shown. The jaws should be fixed to the flange on the conical sleeve. Connect the hydraulic pump and hose. Pull out the conical sleeve.

 Monter verktøyet som vist. Avtrekksklørne skal skyves inn bak avtrekksflensen på konhylsen. Koble til hydraulisk pumpe og slange. Trekk ut konhylse.

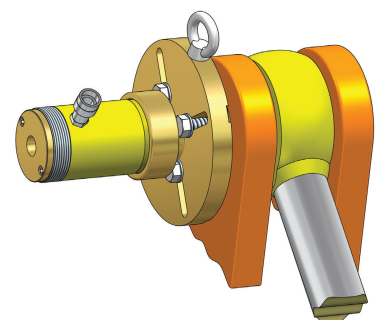



2/ bondura® 6.1

2.2 pin removal / demontering av pin

2.2.1/  The hydraulic puller is fitted to the pulling plate with piston pointed away from the pin.

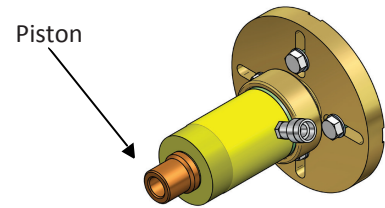
 Jekken monteres til trykkplaten med stempelet pekende fra pin.



2.2.2/  Attach the threaded rod to the pin's center hole, and assemble the tool as shown. Connect the hydraulic pump and hose. Pull out the pin.

 Fest gjengestangen i senterhullet på pin, og monter verktøyet som vist. Koble til hydraulisk pumpe og slange. Trekk ut pin.

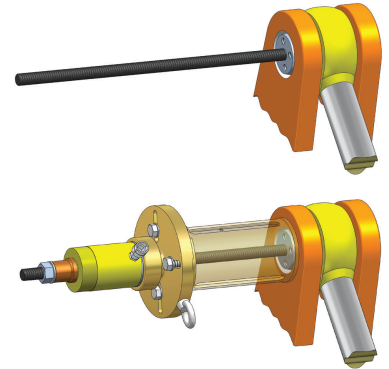

2.2.3/  Screw the axle back to the nut, and pull out the nut and inner conical sleeve.

 Skru akslingen tilbake på mutteren, og trekk ut mutter og indre konhylse.

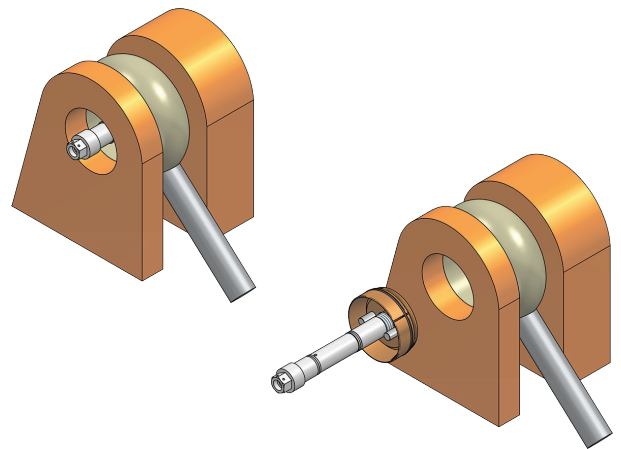

3/ bondura® 6.2

3.1 conical sleeve removal / demontering av konhylse

3.1.1/  To make it as easy as possible to disassemble, the equipment must be offloaded.

 For å gjøre demonteringen enklest mulig, må utstyret avlastes.

3.1.2/  Loosen the nut.

 Løsne mutter.

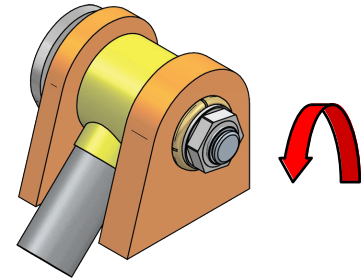

3.1.3/  Remove screws and plate.

 Demonter skruer og plate.

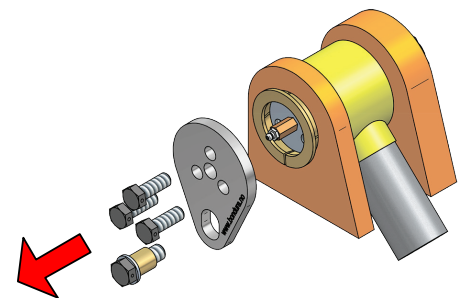

3.1.4/  The hydraulic puller is fitted to the pulling plate with the piston pointed towards the pin.

 Jekken monteres til trykkplaten med stampelet pekende mot pin.

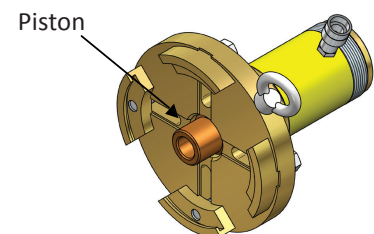

3.1.5/  Assemble the tool as shown. The jaws should be fixed to the flange on the conical sleeve. Connect the hydraulic pump and hose. Pull out the conical sleeve.

 Monter verktøyet som vist. Avtrekksklørne skal skyves inn bak avtrekksflensen på konhylsen. Koble til hydraulisk pumpe og slange. Trekk ut konhylsen.

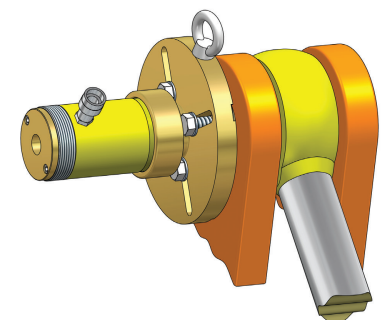



3/ bondura® 6.2

3.2 pin removal / demontering av pin

3.2.1/  The hydraulic puller is fitted to the pulling plate with piston pointed away from the pin.

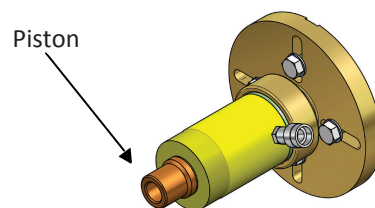
 Jekken monteres til trykkplaten med stempelet pekende fra pin.



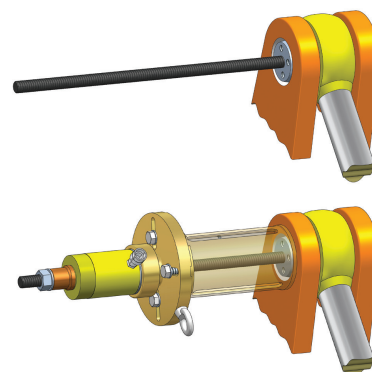

3.2.2/  Attach the threaded rod to the pin's center hole, and assemble the tool as shown. Connect the hydraulic pump and hose. Pull out the pin.

 Fest gjengestangen i senterhullet på pin, og monter verktøyet som vist. Koble til hydraulisk pumpe og slange. Trekk ut pin.



4/ additional / tillegg Ø70mm - Ø135mm

- 4.1/  Conical sleeve removal
Assemble the jaws for Ø70mm - Ø135mm to the pulling plate, and remove the conical sleeves as described in chapter 1.1, 2.1 and 3.1.

-  Demontering av konhylse
Monter avtrekksklørne for Ø70mm - Ø135mm på trykkplaten, og demonter konhylsene som beskrevet i kapittel 1.1, 2.1 og 3.1.

- 4.2/  Pin Ø70mm - Ø135mm removal
Attach the adapter plate to the pin as shown. Screw the adapter plate holder to the adapter plate. Fit the threaded rod and pull out the pin as described in chapter 1.2, 2.2 and 3.2.

-  Demontering av bolt Ø70mm - Ø135mm
Fest adapterplate på pin som vist. Skru adapterplateholderen på adapterplaten. Monter gjengestangen og trekk ut pin som beskrevet i kapittel 1.2, 2.2 og 3.2.



Jaw for Ø70-Ø135

Adapter plate

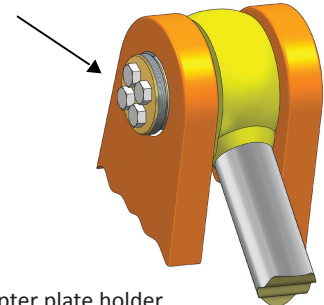

Adapter plate holder

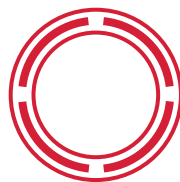
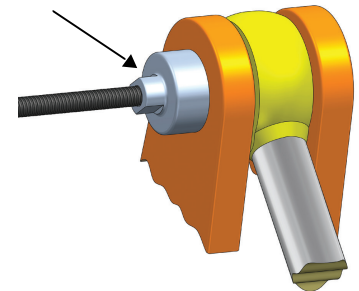

bondura[®]
technology

bondura[®] technology AS
Vardheivegen 56b
4340 Bryne
Norway

support tel +47 51 77 20 20
post@bondura.no
bondura.no