

# CeSTek

## Special modules for mobile robots













**WE DELIVER EFFICIENT SOLUTIONS,  
TO HELP REDUCE MANUAL LABOR.**



**Let the robot do the LIFT - PULL - PUSH**



**INDEX**

Introduction .....	2
Omron Solution Partner - Special Modules Matrix .....	3
CesTek Special modules for Mobile Robots	
 Dox & Accessories.....	4
 Cart & Pallet Stand .....	5
 Pallet - Lift Station.....	6
 Spacers & Accessories .....	7
 Lifters .....	8-9
 Conveyors .....	10-11
 CoPal .....	12
 ArmAnDo.....	13
 WMR .....	14
 MOMA.....	15



**FOR A NUMBER OF YEARS,  
CESTEK AUTOMATION HAS SPECIALIZED IN  
PRODUCING ACCESSORIES FOR OMRONS  
MOBILE ROBOTS.**

**The modules, mounted on a mobile robot,  
increase the efficiency and capacity of your  
production.**

**Whether you are a mobile robot integrator or  
manufacturer, we sell the modules separately,  
so if you already have Omron robots in your  
production, you can simply buy the modules  
you want.**

**If you, as a manufacturer, are about to start  
implementing mobile robots in an existing  
production, then we can also help - we have  
the experience and are always ready for a  
dialogue about the considerations and issues  
you have, in connection with the integration  
of one or more mobile robots in an existing  
environment.**

# A mobile robot solution for your needs...

**OMRON**

SOLUTION PARTNER

## COMPABILITY MATRIX - CESTEK SPECIAL DESIGNED MODULES

Available/recommended add ons

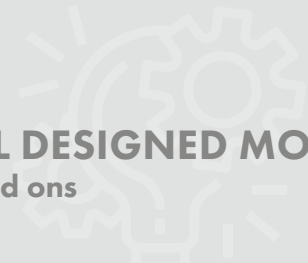



Omron Robot	Transport of	Lift	Conveyor	Spacer	Cart 500	Cart Coupling	Pallet Stand
<b>LD-60/90</b>	Boxes- Trays - Sacks	REX 100	CNV61R CNV62R	•	•	DOX 100*	
<b>LD-250</b>	Boxes - Trays - Sacks - Half Pallet	REX 250 C REX 250 M	CNV61R250	•	•	DOX 250	
<b>MD-650/900</b>	EUR-Pallet	REX 650* HDX 30-2	CNV61R650*		•	DOX 1000*	•
<b>HD-1500</b>	US-Pallet 2 x EUR-Pallets	REX 1250 HDX 35C HDX 30-2	CNV61R1500				•

\* not shown in catalog



### DOX 250

Type: CesTek trolley coupling  
SKU: 20110000

-  LD-250
-  500 kg
-  Datasheet

Add-on for autonomous mobile robots, moving loads of up to 500 kg. Ensures an easy and reliable connection of mobile robot and cart. Made of solid materials that can withstand an industrial environment. Can easily dock in and out of a cart with your mobile robot, to take the cart and drop it off at a desired location.

We supply both the unit for the robot and the number of top units for carts you need. The trolley coupling is delivered incl. control box and drawings of interface.



### DOX universal top

-  LD-250

Type: Unit for cart  
SKU: 20110002

Unit for cart, used with DOX 250 on your own cart.

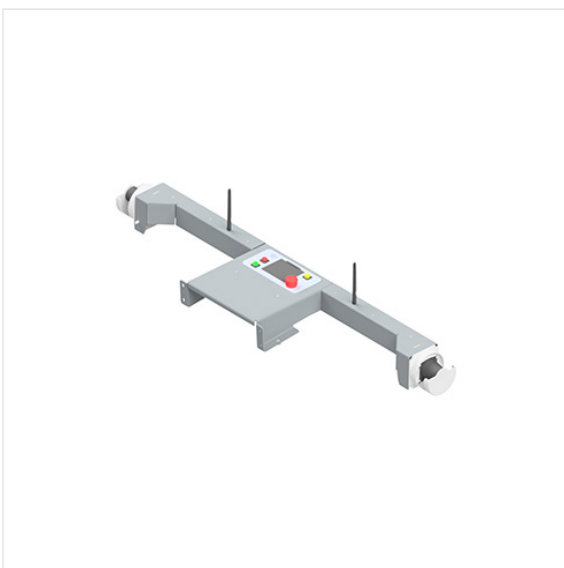

### Sidelaser Boom

-  LD-250

Type: Boom for sidelaser mounting  
SKU: 20110003

Boom for sidelaser mounting on LD-250 used with CesTek trolley coupling.



### CART 500

Type: Cart transport for LD-250  
SKU: 20106000

Transport of boxes, pallets, sacks etc. up to 500 kg.  
Used with DOX 250, which hooks up with the cart and drives it to the designated station.

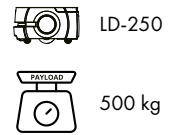

### Pallet Stand

Type: Generic Pallet Stand  
SKU: ST 20201000 /WD 20201500

CesTek Generic Pallet Stand is compatible with HD-1500 or \*MD-650 - equipped with HDX 30-2 pallet lift.  
The pallet stand can also be serviced with a truck or electric pallet lifter.  
The stands can be setup for both EUR pallets or US pallets. With bolt holes for floor fixation. Pallet platform height 340 mm.

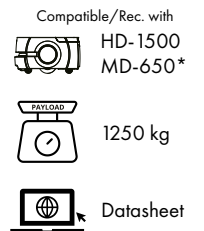

 Click to see video



**NEW**  
Coming soon



**ELV 1000**



Type: Lift Station  
SKU: 20150000

Lift station, designed to exchange pallets with a autonomous mobile robot MD-650 equipped with HDX 30-2 lift. The robot docks in to the lift station, which elevates/lower the pallet from/to the floor.

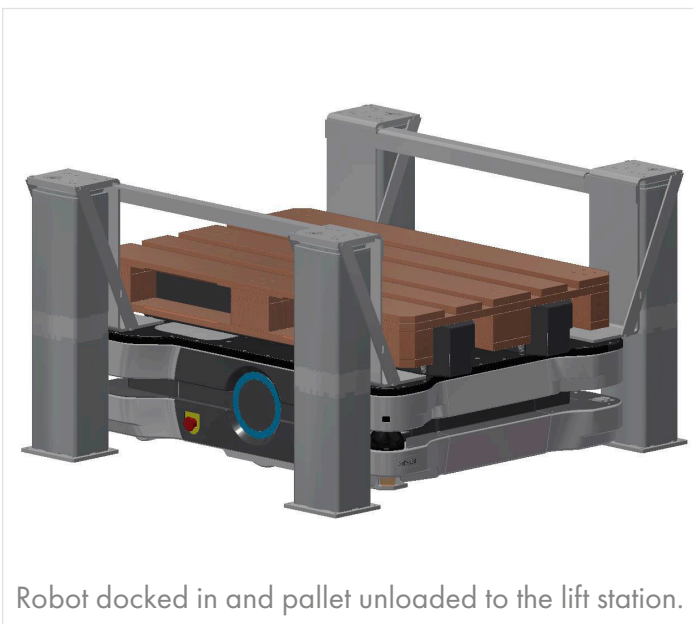

Robot docked in and pallet unloaded to the lift station.

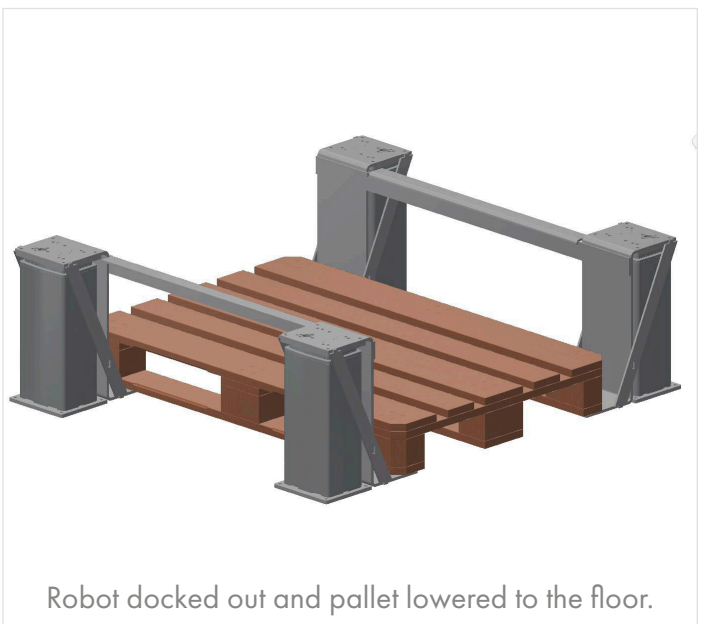

Robot docked out and pallet lowered to the floor.



### Spacer

 LD-60/90

Type: Spacer for LD-60/90  
SKU: 423022-0002

- Powder coated aluminium
- 24 V IO controller
- Available in variable height, minimum 150mm

#### Options:

Extra emergency stop  
PLC for advanced control and data processing  
Side Laser Kit

#### Options:

Extra emergency stop  
PLC for advanced control  
and data processing  
Sidelaser Kit

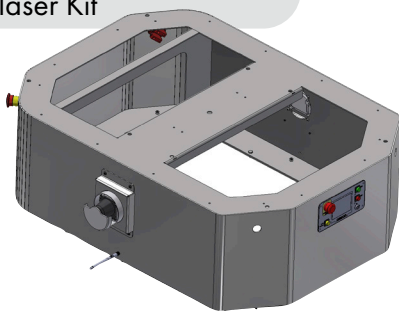

### Spacer

 LD-250

Type: Spacer for LD-250  
SKU: 423022-0003

Designed to match the body of the LD250 at 100%. Standard height 420 mm. Has mounting plates for sidelasers, extra emergency stop buttons and blue light in front. Easy access hatch, for service inside the spacer.

- Powder coated aluminium
- 24 V IO controller
- Available in variable height, minimum 150mm



### L-Shape

Type: Accuracy guide for mobile robot  
SKU: 423021-0010

Mounted under conveyors etc. for optimized accuracy of Omron Mobile robots.

- Caps license needed
- Powder Coated Aluminum

Compatible with our floor conveyors CNV61F, CNV62F and Cart 500



**REX 100**

LIFTING HEIGHT 420 mm

 LD-60/90

PAYLOAD 100 kg

 Datasheet

Type: Lift  
SKU: 20082000+ 20082205 (Bellow Cover)

Add-on for autonomous mobile robots, and/or as a stationary workplace - lifting equipment or other loads of up to 100 kg.

Dimensions L 632 mm x W 452 mm  
Height 120 mm  
Lifted height 420 mm in 60 seconds.  
Transport of boxes, trays, sacks etc.



**REX 250 C**

LIFTING HEIGHT 490 mm

 LD-250

PAYLOAD 200 kg

 Datasheet

Type: Lift  
SKU: 20220000

Add-on for autonomous mobile robots, and/or as a stationary workplace - lifting pallets and other loads of up to 200 kg.

Dimensions L 943 mm x W 690 mm  
Height 170 mm  
Lifted height 440 mm  
Transport boxes, trays, sacks, half pallets, etc.

Can be combined with our top conveyor CNV61R 



**REX 250 M**

LIFTING HEIGHT 1060 mm

 LD-250

PAYLOAD 100 kg

 Datasheet

Type: Lift with extra height  
SKU: 20085000

Add-on for autonomous mobile robots, and/or as a stationary workplace - lifting equipment or other loads up to 100 kg.

Dimensions L 943 mm x W 690 mm  
Height 180 mm  
Lifted height 1060 mm  
Transport boxes, trays, sacks etc.

Can be combined with our top conveyor CNV61R 



Improved life cycle  
500.000 lifts



### REX 1250 LL

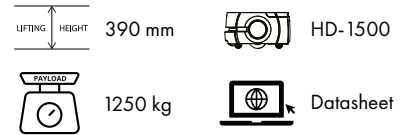

Type: Lift  
SKU: 20091600+20090030 (Bellow Cover)

Add-on for autonomous mobile robots, and/or as a stationary workplace - lifting pallets and other loads of up to 1250 kg.

Dimensions L 1260 mm x W 820 mm  
Height 130 mm  
Lifted height 390 mm  
Transport: boxes, trays, pallets, sacks etc.

Can be combined with our top conveyor CNV61R250 [↗](#)



### HDX 35C

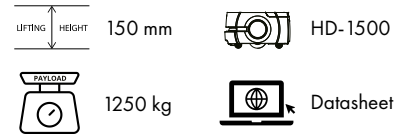

Type: Low lift  
SKU: 20072000

Add-on for autonomous mobile robots, and/or as a stationary workplace - lifting pallets and other loads of up to 1200 kg.

Dimensions L 1324 mm x W 884 mm  
Height 90 mm  
Lifted height 150 mm  
Transport boxes, trays, sacks, pallets, etc.

Can be combined with our top conveyor CNV61R250 [↗](#)

NEW  
**HDX 40E**  
with increased  
payload **1500 kg**  
AVAILABLE



### HDX 30-2

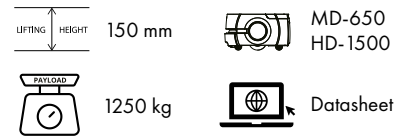

Type: Lift  
SKU: 20050005

Add-on for autonomous mobile robots. Lifting pallets of up to 1250 kg from a pallet stand. Drives it to the destination and delivers it on another pallet stand.

Dimensions L 1200 mm x W 161 mm (each leg)  
Height 90 mm  
Lifted height 150 mm

Recommended with our Pallet Stand 20106100 [↗](#)  
or Lift station ELV 1000 [↗](#)



**CNV61R60**

Type: Top Conveyor - Single  
SKU: 423022-0000

- CesTek Spacer
- Conveyor with aluminium Chassis
- Steel Rollers

**Option:**  
PUR-coated rollers

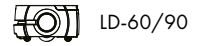

LD-60/90



Datasheet



**CNV62R60**

Type: Top Conveyor - Double  
SKU: 423022-0001

- CesTek Spacer
- Conveyor with aluminium Chassis
- Steel Rollers

**Option:**  
PUR-coated rollers



LD-60/90



Datasheet

**Options:**  
PUR-coated rollers  
Lifting unit (instead of spacer)  
Sidelasers  
420/820 mm conveyor



**CNV61R250**

Type: Top Conveyor - Single  
SKU: 423022-0005

Cestek top single conveyor with drum motor, spacer and electrical equipment. Designed to receive and unload boxes from conveyor. Conveyor has sensors for box detection built in.

- CesTek Spacer (H 150-800 mm)
- Conveyor with aluminium Chassis
- Steel Rollers W 620, pitch 90 mm
- Std. height 800 mm to roller top

Dimensions L 1050 mm x W 720 mm



LD-250



Built-in  
Sensor



**CNV61F**

Type: Floor Conveyor - Single  
SKU: 423023-0000

- Steel frame
- Steel rollers
- Standard conveyor width 420 mm
- Electric: 24VDC Drum motor with speed control or 230 V Conveyor control

Compatible/Rec. with

LD-60/90

50 kg

Datasheet

**Options:**  
Optional width  
PUR-coated rollers  
System control for subsequent conveyors



**CNV62F**

Type: Floor Conveyor - Double  
SKU: 423023-0001

- Steel frame
- Steel rollers
- Standard conveyor width 420 mm (per lane)
- Electric: 24VDC Drum motor with speed control or 230 V Conveyor control

Compatible/Rec. with

LD-60/90

50 kg

Datasheet

**Options:**  
Optional width  
PUR-coated rollers  
System control for subsequent conveyors

**Options:**  
PUR-coated rollers  
Sidelasers  
Lifting unit  
Pallet stand  
Weight measurements



**CNV61R1500**

Type: Top Conveyor - Single  
SKU: 423022-0006

CesTek single Conveyor for HD 1500, drum motor, spacer and electrical equipment. Conveyor has sensors for pallet detection built in.

Transport of EUR, US and half pallets

Dimensions: L 1324 mm x W 884 mm x H 190 mm  
Weight 150 kg

Compatible/Rec. with

HD-1500





1500 kg

Built-in Sensor



**CoPal**

Type: Enterprise  
SKU: 30010012

	90-180 cm Lift Column		TM-12
	12"		12 kg

When your company wants to automate palletizing with one complete purchase. In collaboration with Omron, we deliver the complete solution for palletizing.



With the Enterprise-package you get:

- All from CoPal Pro
- TM12 cobot from Omron
- Standard tool for cardboard boxes



**CoPal**

Type: Pro  
SKU: 30010011

	90-180 cm Lift Column		Compatible/Rec. with TM-Series
	12"		

A flexible plug & play solution for your own cobot.

With the Pro-package you get:

- All from CoPal Basic
- Complete electrical panel
- PLC-based solution
- HMI which makes it easy to configure the setup
- Intuitive operator control



**CoPal**

Type: Basic  
SKU: 30010010

	90-180 cm Lift Column
---	--------------------------

Basic element for those of you who supply robots and controls yourself.

Basic-package includes:

- CoPal frame
- All metal parts and our custom designed lifting column\* (90-180 cm.)
- Fuse, cable, freight and full documentation

\*enables your robot to palletize up to 180 cm in height



### ArmAnDo

Type: Compact Multifunctional Turntable with Conveyor and cobot base (ex. cobot)

With the Standard-package you get:

- Cobot base (robot not incl.)
- Integrated conveyor
- 360° Safety Scanners
- Accuracy - 0,01 mm
- Repeatability - 0,02
- Rotation speed - 0,83 r/m
- Easy access HMI - Floorstanding
- L1600 x W1200 x H800 mm



Datasheet



Multi-Functions



12"



Safety Scanner

Recommended add-ons



TM-Series



90-180 cm Lift Coloumn



LD-Series

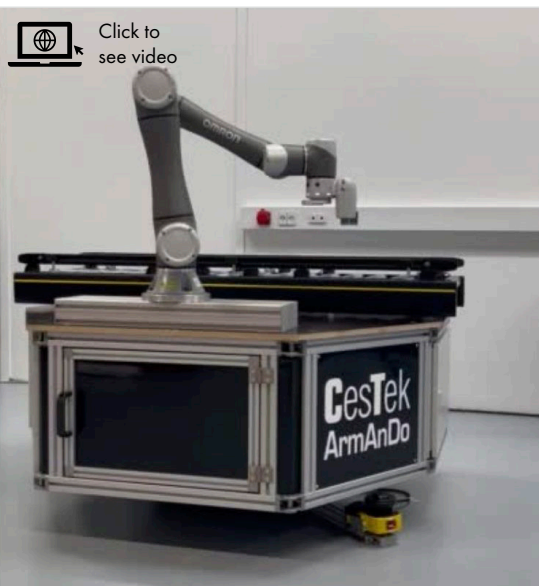
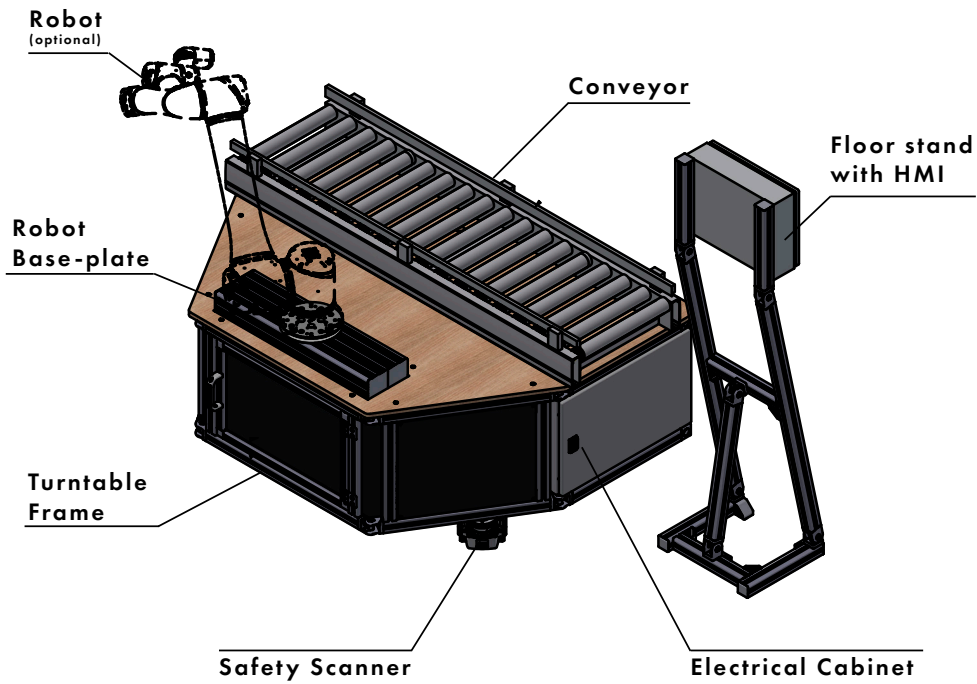

 Click to see video





## WMR

 LD-60/90

Type: Warehouse Management Robot

We deliver an integrated solution that includes both software and robots, so that it fits your specific needs. We adapt the solution to the number of racks and the size of the boxes needed in your warehouse.

The solution can handle many of the physical and routine tasks, so that your employees get rid of the tedious work tasks and thus you achieve a better working environment.

By choosing our solution, you will be able to process several orders with the same staff and at the same time achieve a faster delivery because the unproductive time for the employees is minimized, as they do not have to go so many times between storage locations and packing tables.

A mobile robot solution like this gives you an opportunity to automate part of your warehouse without having to invest in a fully automatic solution.

In short, you achieve:

- Increased order flow with the same staffing
- Better working environment
- Minimized picking time



 Click to see video



## MOMA

Type: Mobile Manipulator  
SKU: 423022-0004



TM-12



LD-250

CesTek Mobile Manipulator, ex. gripper

MOMA is overall a Omron LD-250 with a reinforced CesTek Spacer and a TM-12 on top.

MOMA is designed to bring higher autonomy to production machines, it enables loading and unloading of parts without human intervention. Additionally, the automation of parts handling between different production operations such as measuring, marking or packaging, can be accomplished.

The Kit contains:

- 1x LD-250
- 1x Battery LD-250
- 1x CesTek Spacer for LD-250
- 1x TM 12

### Option:

Sidelasers



# CesTek

---

**CesTek A/S**

**Bogensevej 9  
DK-4200 Slagelse**

**Hattingvej 7C  
DK-8700 Horsens**

**T: +45 30499050  
info@cestek.dk**

**[www.cestek.dk](http://www.cestek.dk)**



Scan to view online pdf