

DESTACO FOOD AND PACKAGING SOLUTIONS

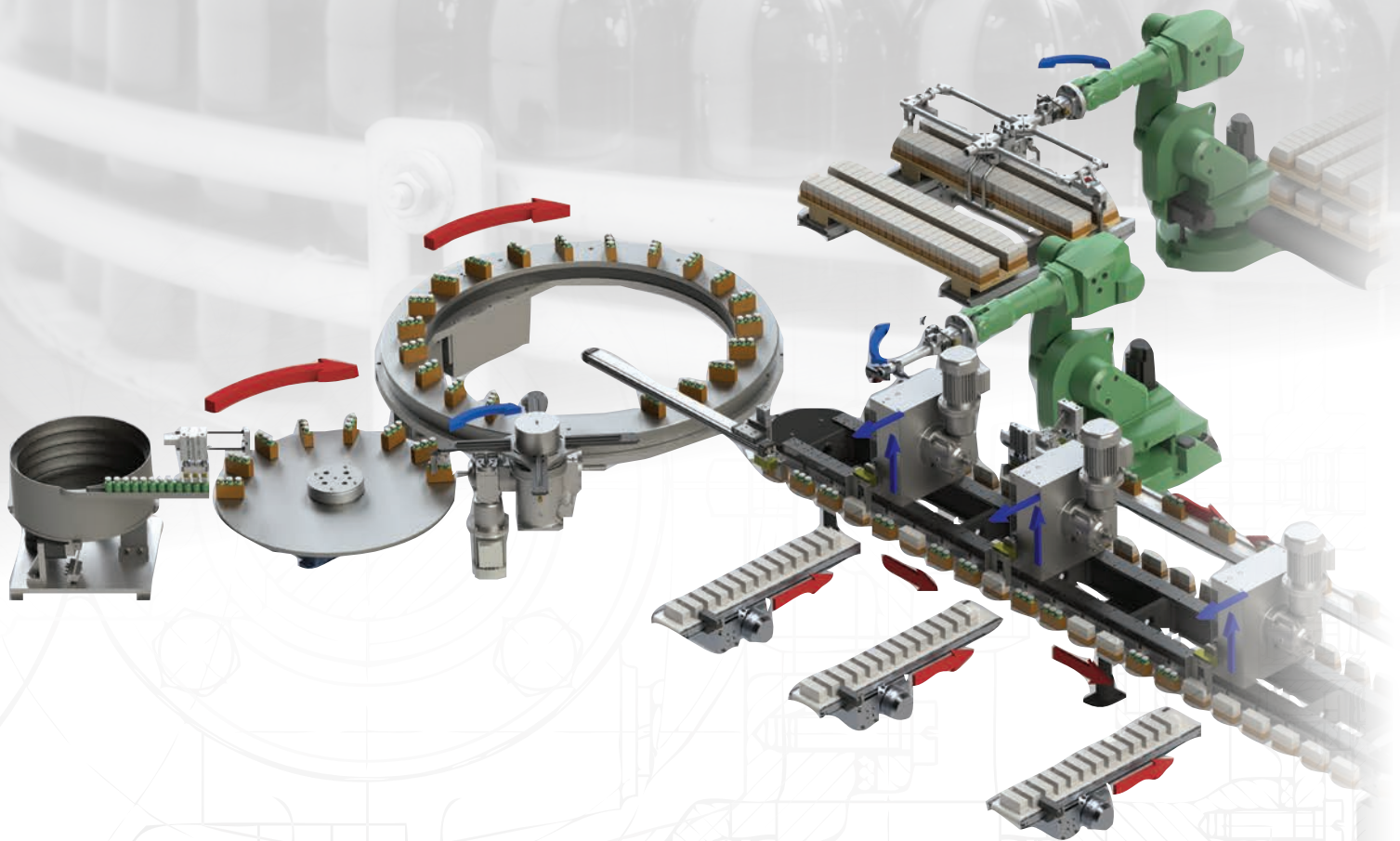

End Effectors	Grippers	Indexers
Manual Clamps	Power Clamps	Remote Handling



destaco.com

Built on a Strong Foundation



Grippers, Rotaries and Linear Slides

Indexers, Positioners, and Conveyors

End Effectors and Vacuum Products

Manual and Pneumatic Clamps



Power Clamping and Locating

Remote Handling and Containment

DESTACO, a Dover company, is a global leader in the design and manufacture of high-performance automation, workholding and remote-handling solutions. The company serves customers in a variety of end-markets, including the automotive, life sciences, consumer packaged goods, aerospace, industrial and nuclear sectors.

Built on a legacy of more than 100 years, DESTACO offers a comprehensive portfolio of products designed to engineer precise movement, placement and control solutions that drive productivity and uptime for manufacturers around the world. The DESTACO family of products consists of industry-leading brands such as DESTACO Manual Clamps, Power Clamps, and End Effectors; CAMCO™ and Ferguson™ Indexers; Robohand™ Grippers; and CRL™ Manipulators and Transfer Ports.

DESTACO is based in Auburn Hills, Michigan, U.S.A. The company has more than 800 employees with 13 locations, in 9 countries, across the Americas, Europe and Asia.

DESTACO is part of Dover Corporation, a diversified global manufacturer with annual revenues of \$7 billion. The company delivers innovative equipment and components, specialty systems and support services through four major operating segments: Energy, Engineered Systems, Fluids, and Refrigeration & Food Equipment. Headquartered in Downers Grove, IL, (NYSE: DOV)

More information is available at destaco.com and dovercorporation.com

Focusing all our Resources

New Product Development

DESTACO has dedicated resources to design and build the next generation of products and solutions

Customer and Technical Service

DESTACO has industry leading global support to address any product and application concerns you may have

Design Tools

DESTACO provides an extensive CAD library, sizing software, and online tools to support our global customers



Our Insight Working for You

Application Engineering

We utilize our expertise and complete portfolio of products to create solution that fit our customers' needs and applications

Custom Solutions

if our off-the-shelf solutions don't fit, we will partner with our customers to develop products that will



Food and Packaging Solutions

DESTACO offers a wide array of products and solutions specifically designed for the food processing and packaging industry.

These solutions provide efficiency and reliability for reducing downtime and waste during the handling of product in a sanitary automated environment.

Whatever the demands of your food production environment, DESTACO can provide an efficient solution to reducing your labor costs and increasing productivity.

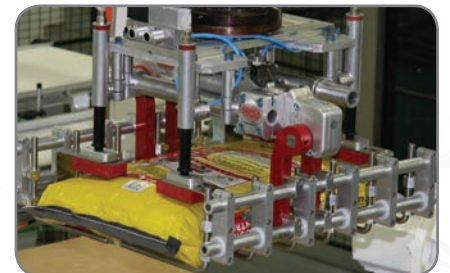

COMPLETE HIGH SPEED PRECISION SOLUTIONS

DESTACO, with CAMCO and Robohand products, offers a comprehensive array of standard and custom automation solutions for high speed, precision indexing and pick-and-place applications for the food processing and packaging market.

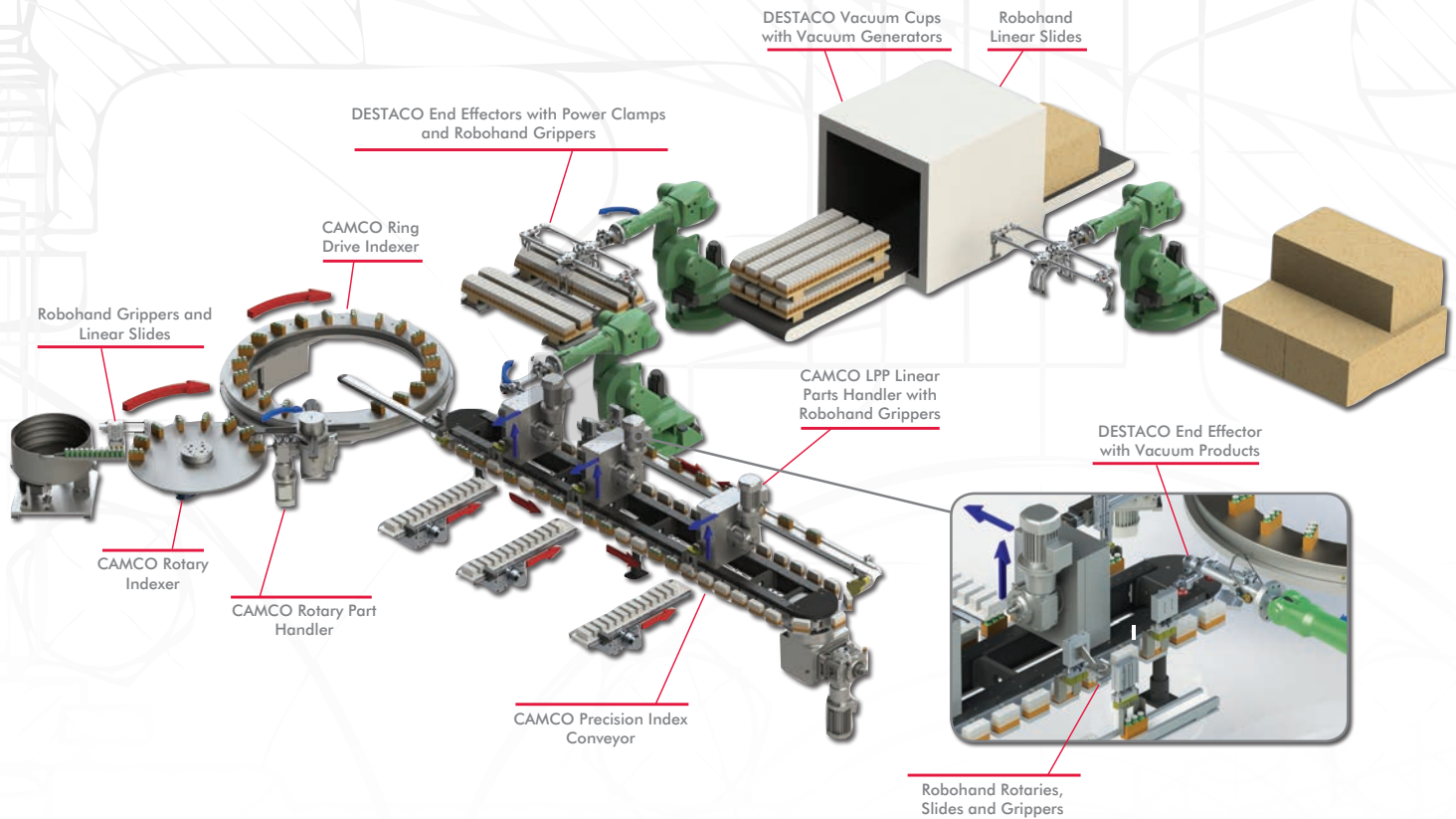

With many years of experience working with OEM machine builders, we can make our product fit your unique application. We will partner with you to design the right product for your application – from altering an existing product to building a completely new product, we have the experience and expertise to help your project succeed.

Using our expertise to develop custom solutions for unique applications, DESTACO helps you save time and resources, allowing you to focus on your core business and gain a competitive advantage in the marketplace.

- Proven quality from the experts
- Reduce risk by using our experienced engineers
- Easy reordering with unique part numbers
- Simplify your supply chain
- Three levels of customization from simple alterations to complex custom products

CAMCO Servo-Mechanical Rotary Positioners

These rotary drives come in medium and heavy duty versions ideal for rotary dial applications and feature a large center through-hole for fixtures and utilities.

- Zero backlash for precision indexing
- Maintenance-free mechanical and servo-based indexers
- Rotary index drives offers robust superior load capabilities
- Offered with several motor manufactures and optional output overload clutches

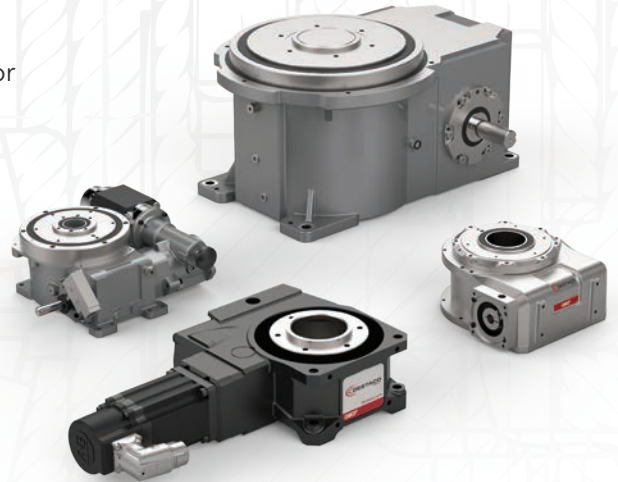

CAMCO RNG Series Ring Index Drives

The main feature of the ring drive is the large center opening which minimizes your machine footprint. This allows a customer to mount equipment inside of the through-hole.

- Standard and custom high precision, hardened cams available
- 60 Station capacity, Ideal for pick, place, and position applications
- Sealed 4-point contact output bearing for superior accuracy and load capability
- Superior accuracy at the working radius when compared to a traditional indexer

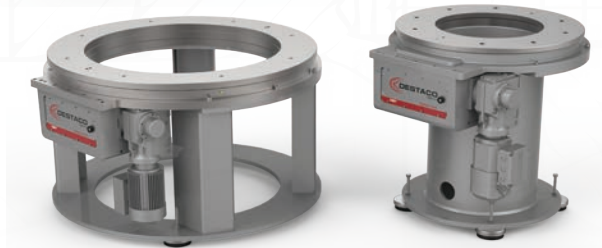

CAMCO Part Handlers

CAMCO Linear and rotary parts handlers offer a low maintenance, cost-effective solution for Automated production systems with small parts transfer such as consumer products, electronics, and medical device assembly and test.

- Designed for high-precision, high capacity applications
- Rugged, precision cam mechanism for maintenance-free operation
- Standard or custom strokes and timing can be designed per request
- LPP series offers easy integration with other DESTACO products for complete automation solutions

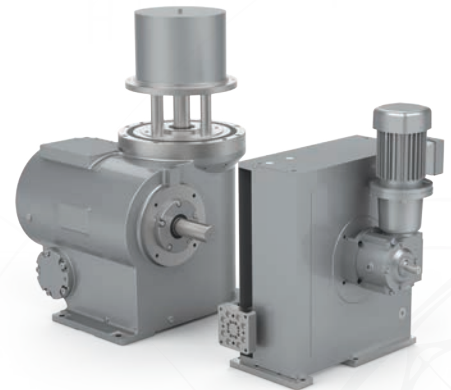

CAMCO Modular Conveyors

Table-Top and Heavy-Duty conveyors are ideal for multi-station assembly of more complicated products. The iQue™ intelligent conveyor adds a greater level of flexibility with infinite possibilities.

- Precision positioning for assembly and manufacturing
- Combines excellent accuracy and high load capacities
- Can be configured in a carousel or over-under style
- Standard modules for flexible lengths, heights or shapes

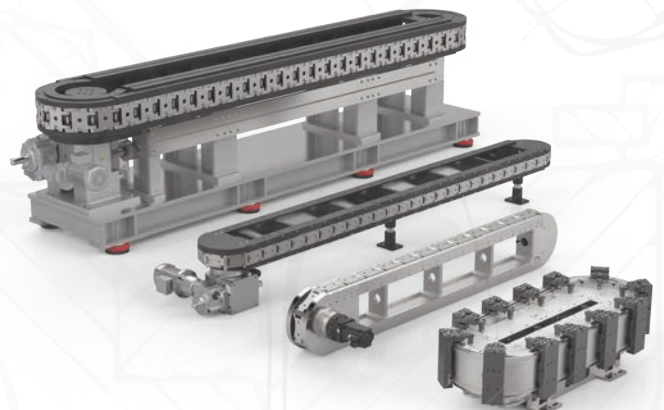

Electric Parallel Grippers

DESTACO's Robohand zero-maintenance electric grippers deliver faster installation, lower maintenance costs, increased reliability over traditional pneumatic grippers. Gripper open and closed operation is controlled using a discrete output from an industry standard controller such as a PLC.

- Light switch operation - no tuning or programming required
- Zero maintenance required for standard environments
- Units are internally lubricated and sealed

Pneumatic Grippers, Rotaries and Slides

DESTACO has Robohand products designed for use in the food and packaging market. This is highly configurable automation product line that adapt to industry and application changes

- DirectConnect Mounting system allows grippers, rotaries and slides to be mounted quickly and easily without adaptor plates
- Rollers are made of oil and cut-resistant neoprene and nitrile material

Specialty Grippers

The FUA Series is designed for direct product contact in the food zone. It features an electro-polished exterior with no recessed or inaccessible zones, preventing retention of contaminants and simplifying cleanings.

- Design according to food industry standard: EN1672-2
- Stainless Steel design provides resistance to chemical cleaning procedures
- Sealed design to resist high pressure wash down

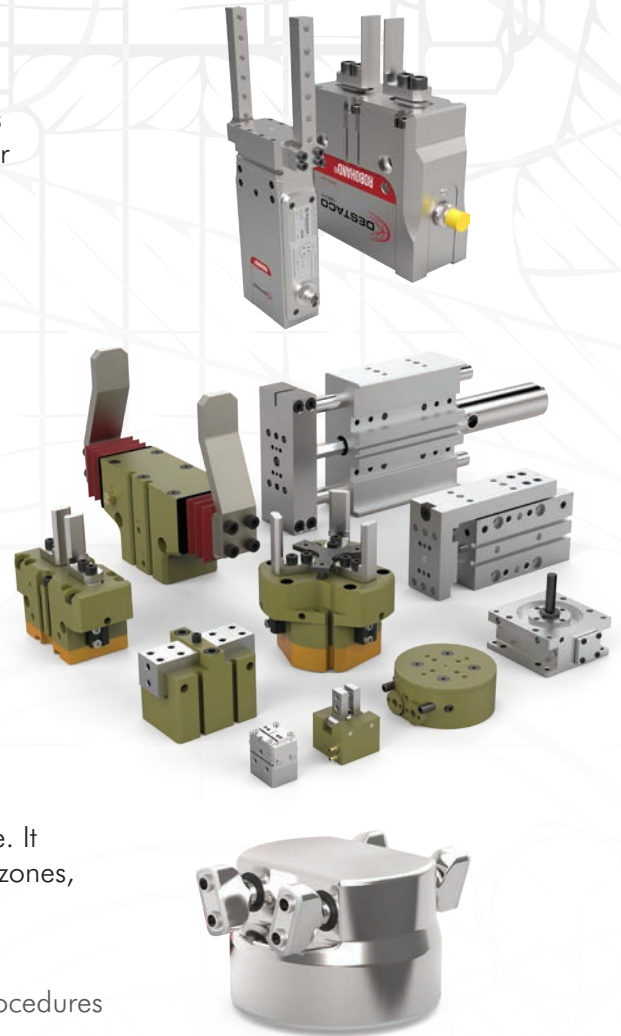

Electric Parallel Grippers	
Rating	RPE-100 DPE-200 DPE-400
10	☉ ☉
100	☉ ☉
1000	☉ ☉
10000	☉ ☉
100000	☉ ☉

Pneumatic 2-Jaw and 3-Jaw Grippers	
Rating	RPMC RPLC DPDS DPDL DPG DPP RDH RTH DCT
10	☉ ☉ ☉ ☉ ☉ ☉ ☉ ☉ ☉
100	☉ ☉ ☉ ☉ ☉ ☉ ☉ ☉ ☉
1000	☉ ☉ ☉ ☉ ☉ ☉ ☉ ☉ ☉
10000	☉ ☉ ☉ ☉ ☉ ☉ ☉ ☉ ☉
100000	☉ ☉ ☉ ☉ ☉ ☉ ☉ ☉ ☉

Rotary Actuators	
Rating	DRG DRF RR
10	
100	☉ ☉
1000	☉ ☉
10000	☉ ☉
100000	☉ ☉

Linear Slides	
Rating	DLB DLT DLM
10	
100	
1000	☉ ☉ ☉
10000	☉ ☉ ☉
100000	☉ ☉ ☉

- ☉ Standard Clean Room
- ☉ With use of Scavage Port

Note: All products tested using Krytox™ Grease. Please contact factory for individual test results and additional clean room requirements.

DESTACO Palletizing Solutions

DESTACO DBG Series bag gripping end effectors offer a fast and reliable end-of-line, pick-and-place palletizing solution. The DBG bag gripper has a simplified, lightweight design using standard off-the-shelf components for a maintenance-free operation.

- Simplified design - no complicated linkages
- Field adjustable finger positions and opening angle
- Pneumatic fully enclosed actuator
- Integrated open/closed position sensing

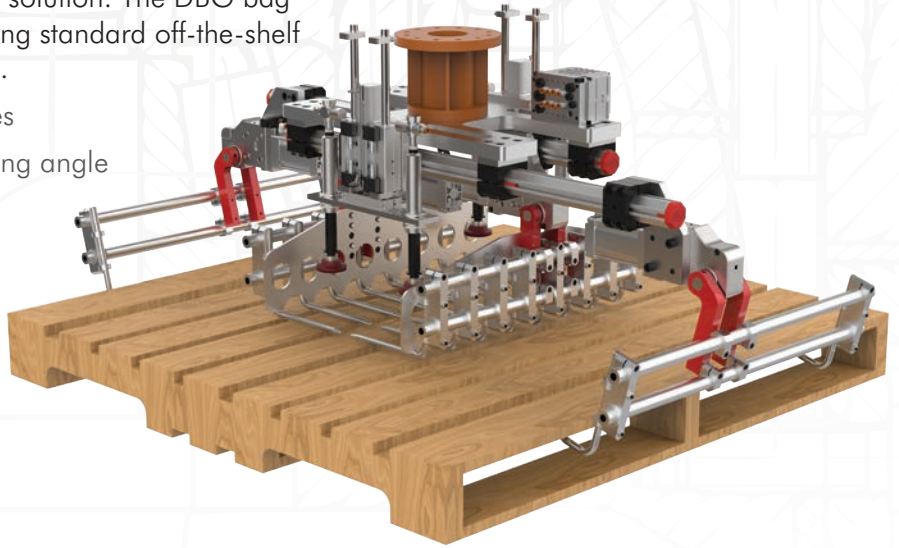
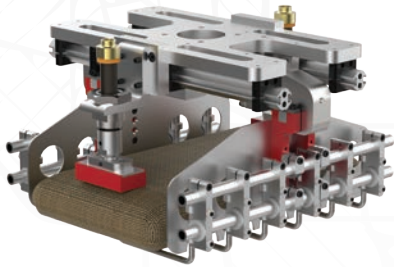

Micro Round End Effector Solutions

A family within the traditional round tooling system, micro tooling components are made from lightweight aluminum with thin wall tubing. This system is designed to handle small, lightweight parts, plastic injection mold unloading, and unusual shaped objects.

- Unlimited configuration possibilities to handle different sized parts
- Can be used with other DESTACO automation products
- Optional quick disconnect air ports provides a simple connection point for air supply when changing between different tooling configurations



Stainless Steel Workholding Clamping Solutions

DESTACO offers toggle clamp models fabricated with corrosion, chemical and heat resistant stainless steel. These clamp models are used in many applications where corrosion is a problem

- Smooth surfaces without burrs
- Rivets made of stainless steel
- Stainless steel spindles with hex heads

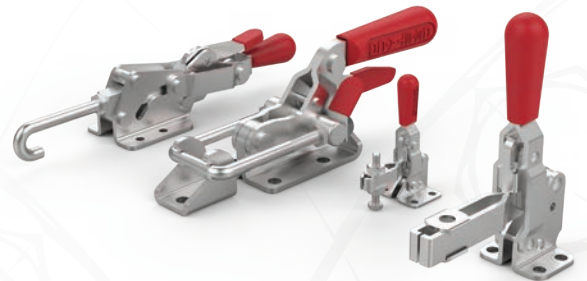



GLOBAL LOCATIONS

NORTH AMERICA

Corporate Headquarters

Auburn Hills, Michigan
Toll Free: 1.888.DESTACO
Marketing: marketing@destaco.com

Global Technology Center

Auburn Hills, Michigan
Tel: 1.248.836.6700
Customer Service: customerservice@destaco.com

Mt. Juliet, Tennessee
Tel: 1.888.DESTACO
Customer Service: customerservice@destaco.com

Wheeling, Illinois
Tel: 1.800.645.5207
Customer Service: camco@destaco.com

Red Wing, Minnesota (Central Research Laboratories)
Tel: 651.385.2142
Customer Service: sales@centres.com

ASIA

Bangkok, Thailand
Tel: +66-2-326-0812
Customer Service: info@destaco.com

Shanghai, China
Tel: +86-21-6081-2888
Customer Service: china@destaco.com

Bangalore, India
Tel: +91-80-41123421-426
Customer Service: india@destaco.com

EUROPE

Oberursel, Germany
Tel: +49-6171-705-0
Customer Service: europe@destaco.com

Sainte Florine, France
Tel: +33-4-73545001
Customer Service: france@destaco.com

Wolverhampton, United Kingdom
Tel: +44-1902-797980
Customer Service: uk@destaco.com

Sant Boi de Llobregat, Spain
Tel: +34-936361680
Customer Service: spain@destaco.com

Uithoorn, Netherlands
Tel: +31-297285332
Customer Service: benelux@destaco.com