

# morbidelli n100

CNC nesting machining centres for drilling and routing

CNC - machining centres



REV. N. 02 - 08.2019



SCM GROUP SPA  
via Casale 450 - 47826 Villa Verucchio, Rimini - Italy  
tel. +39 0541 674111 - fax +39 0541 674274  
morbidelli@scmgroup.com  
www.scmwood.com



00L0365755D



# morbidelli n100

CNC nesting machining centres for drilling and routing

## FOR COMPANIES DEMANDING FLEXIBILITY AND HIGH PERFORMANCE

Machining centre designed and engineered for machining wood, plastics and non-ferrous metals. Due to the unique design and PRO-SPACE safety systems, it requires less floor space and can be operated from all sides for material handling of smaller components.



# morbidelli n100

exclusive features

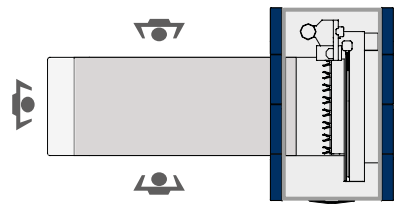

## MINIMUM OVERALL DIMENSIONS AND MAXIMUM FLEXIBILITY: "PRO-SPACE" PROTECTIONS

Loading zone completely free to reduce the space occupied to the minimum.  
The absence of perimeter protections facilitates the work table access on all the sides of the machine.

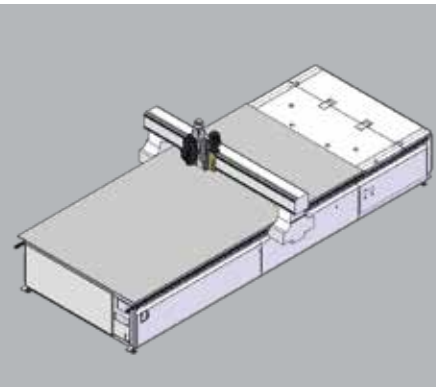

## TOTAL LACK OF VIBRATIONS: MOBILE GANTRY STRUCTURE

Performance without comparison with the mobile gantry structure that allows for high machining speeds whilst guaranteeing the best end products quality.

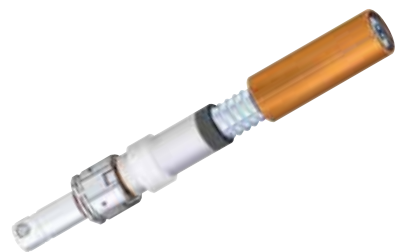

## THE PERFECT DRILLING: RO.AX SPINDLE

Zero play during machining with the new RO.AX technology (Rotoaxial spindle technology), the most efficient spindle on the market with rotation speeds up to 8000 rpm. The sturdiness of drilling heads is proven by the reduced maintenance costs: five times less than that imposed by the majority of other machine manufacturers.

**Maestro**  
CNC

Expand your creativity



scm

## UNIQUE CREATIVITY: MAESTRO CNC

CAD/CAM programming software to design all the production processes.  
Developed in Windows® environment it ensures easy programming with an advanced, simple and intuitive sketching environment that features all the tools necessary to design the parts, their layout on the work table, tools management and the relative machining operations. All the procedures are contained in a perfectly integrated and high performance software.





# morbidelli n100

machining unit

Optimal precision and flexibility in all conditions of use with the 3 or 4-axis routing unit up to 15 kW power. The electrospindle can be equipped with a liquid cooling group that allows to maintain constant the operating temperature.



## NO LIMITS TO MACHINING: INTERPOLATING VECTOR AXIS

360° rotation and automatic positioning on X-Y axes of all angular heads with the interpolating Vector axis digitally managed by the NC.



Efficiency and rigidity during the machining thanks to the drilling heads with up to 18 independent spindles. Easy grooves machining on the sides of the furniture thanks to the integrated blade unit.



## THE PERFECT DRILLING: RO.AX SPINDLE

Zero play during machining with the new RO.AX technology (Rotoaxial spindle technology), the most efficient spindle on the market with rotation speeds up to 8000 rpm.

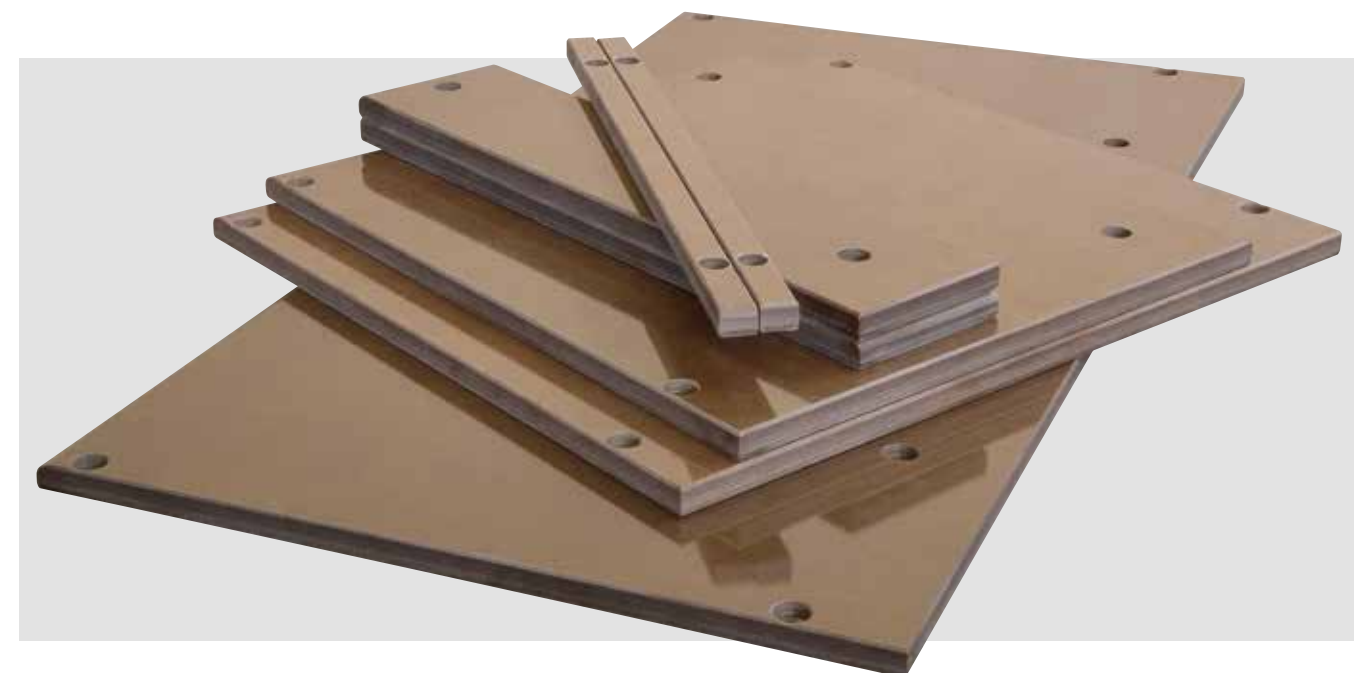
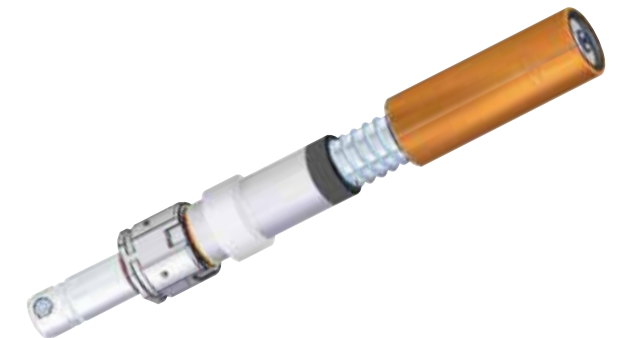

# morbidelli n100

tool changers and machine management



Maximum versatility thanks to the TR side tool changer that greatly reduces the tool changing times.



One position "Pick-up" tool changer with pneumatic positioning fitted on the mobile cross beam. Ideal set-up for large sized angular heads.



**Console with integrated PC "eye-M"**  
Industrial PC with multi-touch colour display, 21,5" screen size, Full HD, positioned on a support base with displacement wheels, for an easy handling of the mobile console along the machine perimeter.

# morbidelli n100

work table

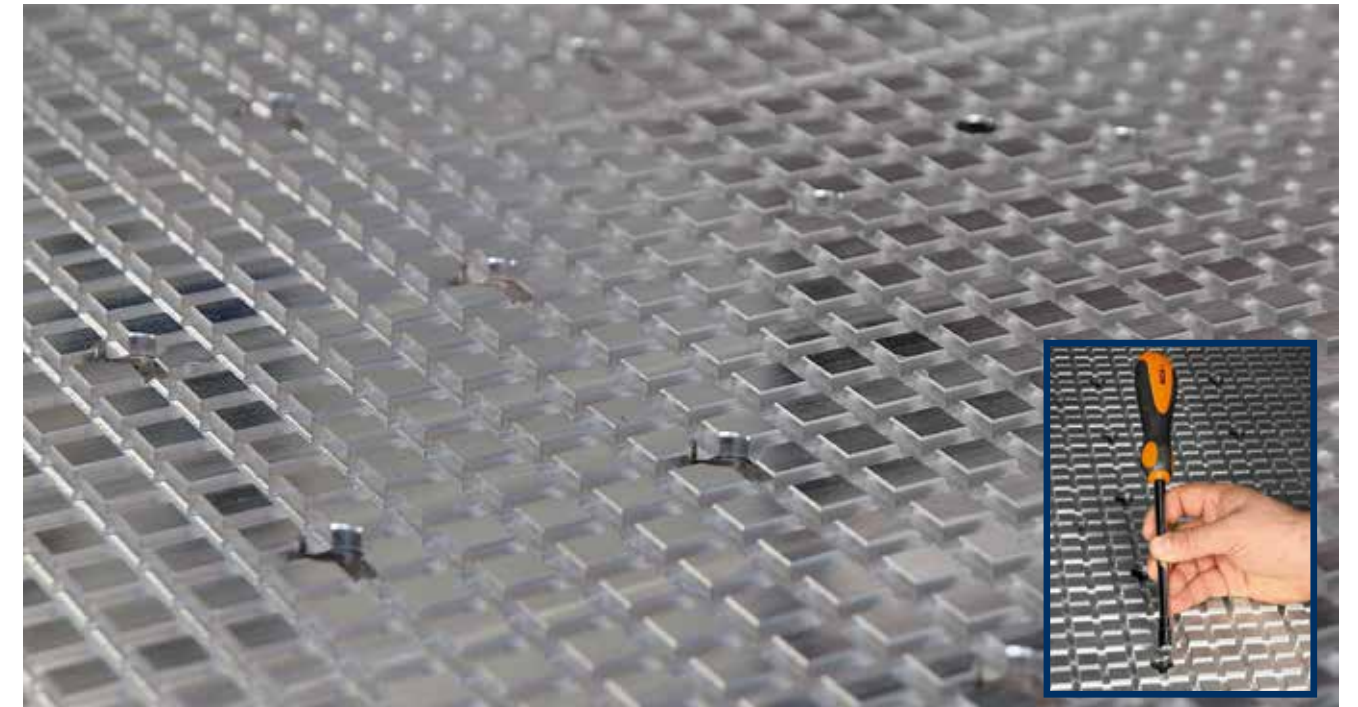

## DESIGNED FOR EFFICIENCY AND SAVING: "H.E." (High Efficiency) WORK TABLE

Sturdy and practical work table, resistant over time thanks to its laminate aluminum structure. Easy and quick setting with the magnetic locking system of the vacuum: in a few seconds the vacuum is activated only in the positioning area of the piece to be machined.



Wide choice of MPS vacuum pods and MODULSET to lock the pieces on the work table depending on the machining operations to be carried out.

## MAXIMUM EFFICIENCY IN ALL MACHINING SITUATIONS: PRESSURE ROLLERS

Perfect holding down of small components or in conditions of reduced vacuum holding, thanks to the pressure rollers. By pressing close to the working area, the rollers are also ideal for the machining of overlapped panels. In case of machining where their use is not foreseen, the rollers are excluded maintaining unchanged the machine performance.





# morbidelli n100

loading/unloading automation



**Clean work environment** with the chips conveying device positioned between the work table and the unloading belt.



**No dust** with the upper extraction system for the work table cleaning.

The perfect solution to easily assist the operator's work  
Nesting cell with loading lifting table and unloading belt (also available with the loading version only or the unloading one).



**Panel cleaning system** which provides an optimum holding down: air micro-jets clean the infeed panel. Automatic lifting of tool changer.



**Perfect alignment** of the loaded panels thanks to the aligning device for infeed work pieces.



**Unloading belt** with photocell detection system.



**100% productivity** with the pusher that moves the processed work pieces on the unloading belt.



**Precise and rapid panels positioning** on the work table with the vacuum pods system.



**Lifting table** for the management of panels stacks with height up to 700 mm.



# morbidelli n100

loading/unloading automation

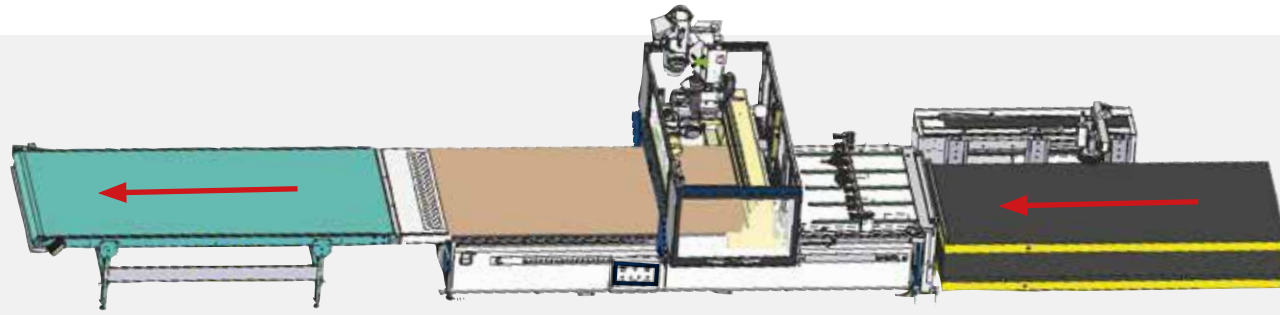

The modular project of the whole system allows to install the whole cell both with the working flow towards the right side and the left side.

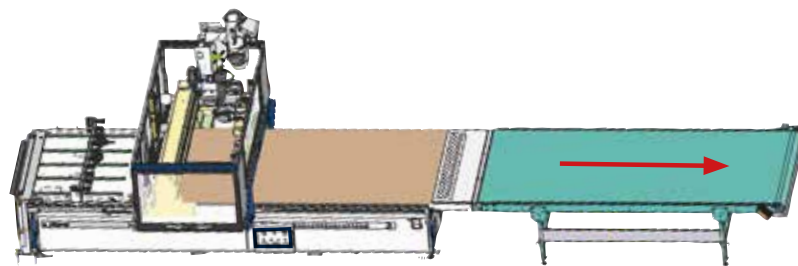
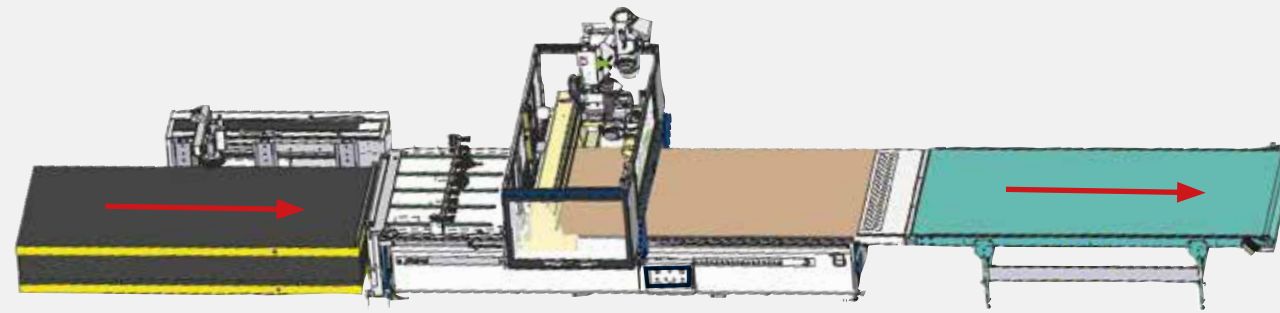

**Partial compositions**  
It is possible to configure the cell with loading only, or with unloading system, with or without belt.

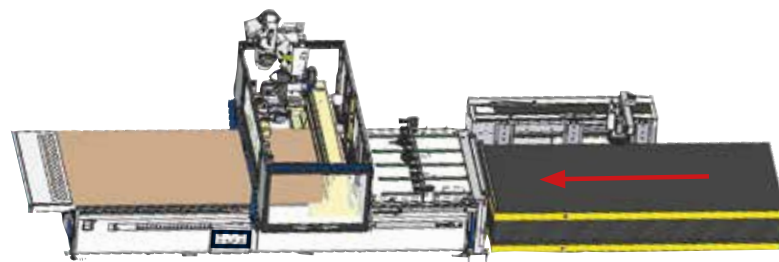

**Manual label printer**  
The operator manually applies the label on the work pieces coming out of the machine.



	Base	01/04/2010
	800 X 720 X 480	15:35:43
PIECE:	Left side	
COLOUR:	BIANCO	THICKN. 18
SIZE:	Dx: 739.0	Dy: 489.0
Edge side 1-3:	 MELA05SS18.05B0.5	
Edge side 2-4:	 MELA05SS18.05B0.5	
CNC Code:	 LSide0 DX739 DY489	



# morbidelli n100

devices for other materials



A range of dedicated heads for the machining of non-wood and advanced materials, such as plexiglas, plastics, alucobond, aluminum, polyurethane foams and honeycomb cardboard.

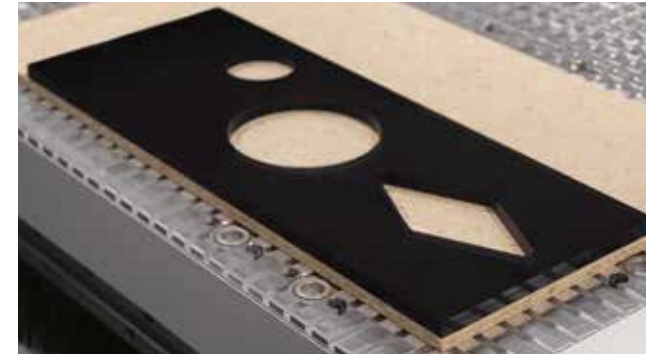

## DEVICES FOR PARTICULAR APPLICATIONS

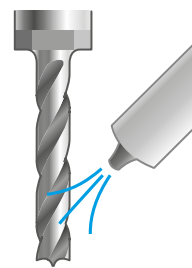

**Air blower on electrospindle**  
For generic applications.

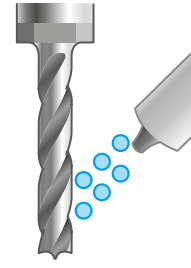

**Ionized air blower on electrospindle**  
It is suitable to eliminate the electrostatic charges due to the cut material, making easier the shavings suction (advisable for plastic materials machining).

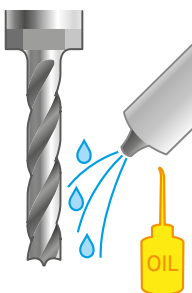

**Air blower with microlubrication**  
Air blower with very little oil quantity for the tool lubrication and cooling when used on coated panels.



**Guides protections, X-Y axes**  
By means of dedicated cleaning and protection system, it allows the machining also on abrasive materials (this device is compulsory for machining on plasterboard material).





# morbidelli n100

other devices

## “ALL” AT YOUR FINGERTIPS: TECPAD CONTROL

Management of machine controls with the 7” colour remote control with touch-screen function that facilitates and speed up the setting operations.



## Bar-code reader

Quick and simple scanning of the label associated to the panel by means the bar-code reader.



## Tool length detection device

Positioned on the machine base side, it allows to automatically detect the length of the tool.



## Possibility of extensive customisation

With angular heads having 1, 2 and 4 outlets with HSK taper couplings for angled routing, drilling and blade grooving, with plays elimination system or fixed mechanical couplings.

# morbidelli n100

## STAND-ALONE

### OVERALL DIMENSIONS AND LAYOUT

		A	B	C
morbidelli n100 12	mm	2190	2552 (3552*)	4565 (5570*)
morbidelli n100 15	mm	2190	2852 (3852*)	5765 (6770*)
morbidelli n100 18	mm	2190	3152 (4152*)	5765 (6770*)
morbidelli n100 22-31	mm	2190	3472 (4472*)	5215 (6215*)
morbidelli n100 22-43	mm	2190	3472 (4472*)	6402 (7400*)

\* It includes the operating area

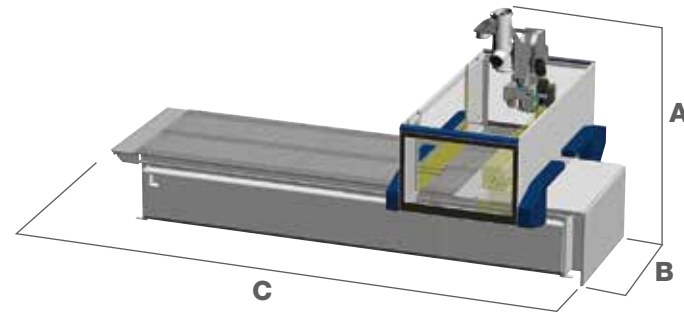

## LOADING AUTOMATION

### OVERALL DIMENSIONS AND LAYOUT

		A	B	C
morbidelli n100 12	mm	2190	2552 (3552*)	7096 (8096*)
morbidelli n100 15	mm	2190	2852 (3852*)	9495 (10495*)
morbidelli n100 18	mm	2190	3152 (4152*)	9495 (10495*)
morbidelli n100 22-31	mm	2190	3472 (4472*)	8340 (9340*)
morbidelli n100 22-43	mm	2190	3472 (4472*)	10725 (11725*)

\* It includes the operating area

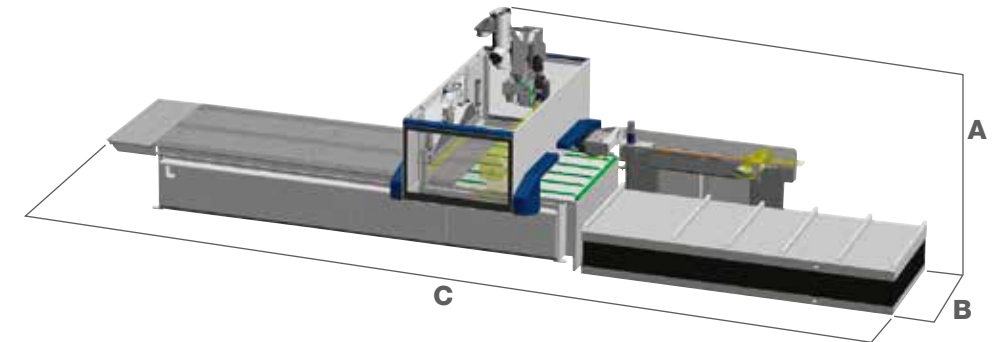

## LOADING/UNLOADING AUTOMATION

### OVERALL DIMENSIONS AND LAYOUT

		A	B	C
morbidelli n100 12	mm	2385	2552 (3552*)	9760 (10260*)
morbidelli n100 15	mm	2385	2852 (3852*)	13375 (13875*)
morbidelli n100 18	mm	2385	3152 (4152*)	13375 (13875*)
morbidelli n100 22-31	mm	2385	3472 (4472*)	11610 (12110*)
morbidelli n100 22-43	mm	2385	3472 (4472*)	15215 (15715*)

\* It includes the operating area

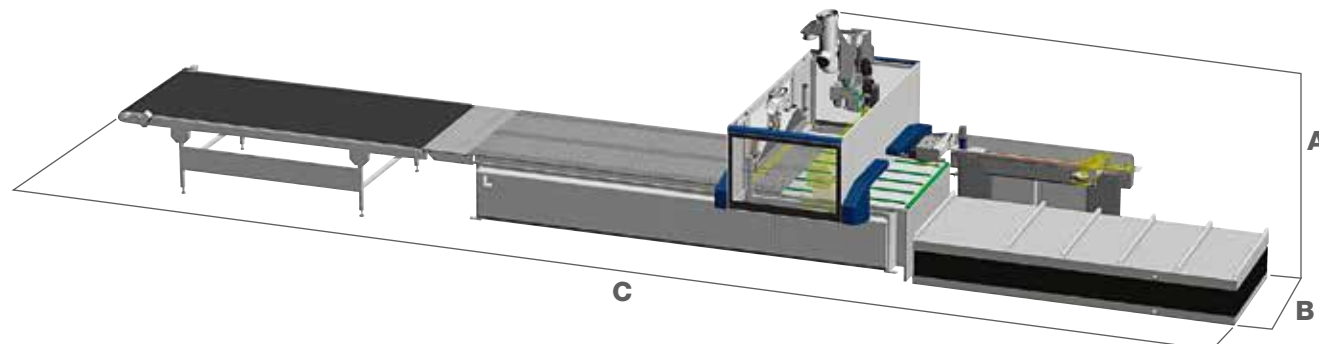

## UNLOADING AUTOMATION

### OVERALL DIMENSIONS AND LAYOUT

		A	B	C
morbidelli n100 12	mm	2385	2552 (3552*)	7250 (7750*)
morbidelli n100 15	mm	2385	2852 (3852*)	9650 (10150*)
morbidelli n100 18	mm	2385	3152 (4152*)	9650 (10150*)
morbidelli n100 22-31	mm	2385	3472 (4472*)	8500 (9000*)
morbidelli n100 22-43	mm	2385	3472 (4472*)	10875 (11375*)

\* It includes the operating area

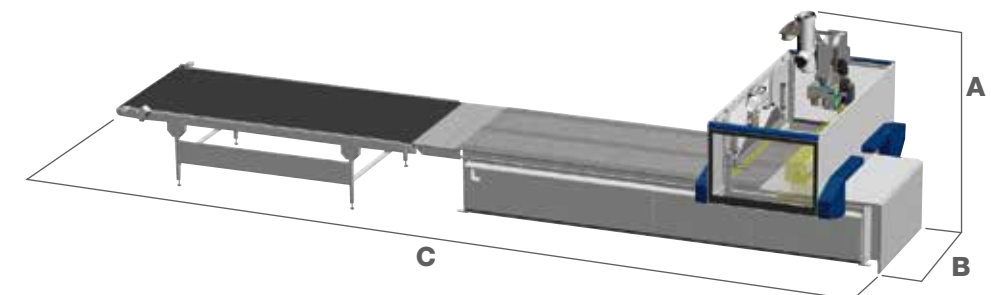



# M Maestro Digital Systems

SMART SOFTWARE AND DIGITAL SERVICES TO ENHANCE PRODUCTIVITY OF WOODWORKING AND FURNITURE INDUSTRIES.

SCM accompanies woodworking companies throughout their whole process combining machines with matching software solutions and digital services, with a constant strive to enhance company productivity.

The software solutions powered by SCM are developed to optimize machine usage as well as the entire process, providing integration with the different software existing in the company.

design > programming and data generation

Maestro office

Office

Factory

Maestro active

cutting > routing drilling

## SOFTWARE

Simple, smart and open Maestro software are tailored on the machine technology as well as on the entire process. All Maestro software share a common mission:

**easy to use**, so that any operator can easily and confidently learn and use the software

**smart**, with algorithms and computing modules aiming at the best possible result

**open in order to integrate** existing software, and provide customer the coverage of all his process.

## DIGITAL SERVICES

Transforming the way it delivers services to its customers through digital technologies and particularly, the IoT platform that collects and analyses data coming from the machine, **SCM created a world of services enabled by Maestro connect**.

Meaning that connecting an SCM machine through Maestro connect will let customer subscribe a program of fast-evolving services and access a wide range of benefits that even go beyond the machine experience and will support and assist you through the whole life-cycle of your machine.

1  
Machine monitoring, KPIs, early warning

2  
Maintenance equipment

3  
Predictive maintenance

4  
Report and historical data export to MES

5  
Warranty extension

6  
Augmented remote support

7  
Smart learning, SELF-HEALING, video tutorials

8  
Asset management with e-shop SCM Spare Parts

Maestro connect IoT Platform







## Maestro cnc

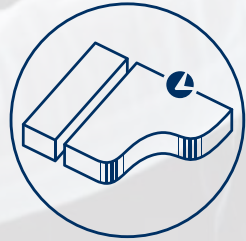

In the office, before the production, the design and programming system Maestro cnc ensures that routing, drilling or sawing can quickly and easily be programmed thanks to 3D graphics of work pieces and machining and clamping aids as well as a smart App and macros library to program any machine operation with a mouse click. Another click away and CNC programs are automatically generated.

### SOFTWARE

#### Office



## Maestro active cnc

Maestro active is the new operator interface software which has been unified across all SCM technologies. A single operator can easily and confidently run multiple machines due to controller and interface consistency: regardless the machine, Maestro active maintains the same look&feel, with many identical icons and navigation buttons, thus ensuring the same approach to interaction.

### EASE OF USE

The new interface has been specifically designed and optimized for immediate use via touch screen. Graphics have been redesigned for simple and comfortable navigation, with tablet-like icons on touch screen controller.

### “ZERO” ERRORS

Improved productivity thanks to integrated help and recovery procedures that reduce the possibility of error from the operator's side.

### SOFTWARE

#### Factory

## Maestro cnc

### THE SOFTWARE THAT SIMPLIFIES THE WORK

CAD/CAM programming software to design all the production processes. Developed in Windows® environment it ensures easy programming with an advanced, simple and intuitive sketching environment that features all the tools necessary to design the parts, their layout on the work table, tools management and the relative machining operations. All the procedures are contained in a perfectly integrated and high performance software.

#### ADDITIONAL FUNCTIONS



##### Maestro 3d - Unique in the creation of 3D objects

The module integrated in the Maestro suite is designed to program three dimensional objects on 5-axis machining centres.



##### Maestro apps - Unique know-how

Maestro apps is a library of programming functions that are always available and easy to use, developed by SCM for the production of parts for doors, windows, stairs, furniture and furnishings.



##### Maestro msl connector - Total integration

Connector for third-parties with design software.

#### SPECIALISED MACHINING



##### Maestro cabinet - Unique in the creation of furniture

This application is designed for the home and office furniture sector to design furniture and program cabinet production step by step.



##### Maestro nest - Unique nesting process

The module integrated in the Maestro suite provides all the functions necessary to manage the “nesting” process: from a simple “rectangular” piece to the most varied and complex “free form” geometrical shapes.



##### Maestro label - Unique labeling process

Integrated module to manage label's models, which develops labels by inserting texts, images, parameters and the main barcode formats.

## Maestro active cnc

### A REVOLUTIONARY APPROACH TO INTERACT WITH YOUR SCM MACHINE

#### FULL CONTROL OF PRODUCTION PERFORMANCES

The creation of customizable reports by operator, shift, program, forecast period (and much more) allows to monitor, optimize and improve the production performance.

#### FULL MACHINE AWARENESS AND KNOWLEDGE MANAGEMENT SYSTEM

Maestro active allows to record the times related to setup, maintenance, training and other events, tracing all the activities in a database. The operator's know-how is also stored and made available to other people inside the organization thanks to the possibility to comment and document all production events or notifications.

#### ORGANIZE YOUR PRODUCTION

Maestro active allows to create different users with different roles and authorizations (e.g.: operator, maintainer, administrator, ...). Any user can only execute the functions whose permissions have been assigned to him. It is also possible to define the work shifts on the machine and then detect activities, productivity and events that occurred in each shift.

#### TOTAL QUALITY OF THE FINISHED PRODUCT

With Maestro active the quality of the finished piece is no longer put at risk by worn tools. The new Maestro Active Tool Life Determination system sends notification messages as the tool reaches its end of life and recommends its replacement at the most appropriate time.

#### TOOLS? NO PROBLEM!

Maestro active guides the operator during the magazine tooling phase, taking into account the programs to be executed.



# A WORLD OF SERVICES FOR GREATER EFFICIENCY

## Maestro connect

### CONNECT YOUR MACHINE AND GAIN ACCESS TO A WORLD OF SERVICES

Connecting your machine through Maestro connect will let you subscribe a program of fastevolving services. You will access a wide range of benefits that even go beyond the machine experience and will support and assist you through the whole life-cycle of your machine.

### FASTER SERVICE INTERVENTION AND PROBLEM RESOLUTION

Maestro connect provides real time data and Health Records of the Machine also to SCM Service drastically reducing its troubleshooting time.

### WORKING ALWAYS IN PERFECT CONDITIONS

Maestro Connect can provide a full kit of sophisticated sensor devices to detect and warn the operator in case of alarming conditions of the machine.

## DIGITAL SERVICES

### SMART MAINTENANCE: DOWN TIME REDUCTION

Maestro connect reduces maintenance downtime thanks to:

- Automatic maintenance notifications and scheduling, to prevent failures and work in the best conditions of use
- Direct connection to SCM Service thanks to an automatic ticket opening function

### SMART MACHINE: ANYTIME, ANYWHERE AWARENESS

Connecting your SCM machine also means having your machine always at hand. Immediate instant notifications in case of alarms or downtimes allow customers to immediately take an action thus optimizing his productivity.

### SMART MANAGEMENT: PRODUCTION PERFORMANCE OPTIMIZATION

Reports and KPIs allow further analysis thus increasing Customer Knowledge about his performance and results.

### SMART PARTS: FAST PARTS REPLENISHMENT

Repairs are scheduled proactively since the system provides Spare Parts suggestions and a direct Integration with Smart Parts e-shop.

### SMART LEARNING: EXECUTE WORK AND RECEIVE PROBLEM SOLVING SUPPORT

Maestro connect provides an intuitive Problem Solving Management System to help the operator to self solve any issue..

### SMARTTECH: FASTER AUGMENTED SUPPORT

Maestro connect allows augmented reality support by means of Smarttech: the head-wearable computers with wireless connectivity that will bring the interaction between customer and SCM service to a higher level.

### SMART WARRANTY: YOUR MACHINE ALWAYS IN PERFECT CONDITIONS

Together with scheduled maintenance contracts, you can take care of your asset by doubling the warranty from 1 year to 2 years\* for complete peace of mind!

\* please read the complete contract to understand terms and conditions.

# morbidelli n100

## MORBIDELLI NI00

## TECHNICAL DATA

MORBIDELLI NI00		12	15	18	22-31	22-43
<b>AXES</b>						
Vectorial speed X-Y axes	m/min	35	35	35	35	35
Z axis stroke	mm	250	250	250	250	250
Z axis panel passage	mm	150	150	150	150	150
<b>ROUTING UNIT</b>						
Motor power (max.)	kW (hp)	15 (21)	15 (21)	15 (21)	15 (21)	15 (21)
Rotation speed (max.)	rpm	24000	24000	24000	24000	24000
Available tools on tool changer (max.)	places	12	15	17	20	20
<b>DRILLING UNIT</b>						
Independent vertical spindles (max.)	n.	12	12	12	12	12
Independent horizontal spindles (max.)	n.	6	6	6	6	6
Rotation speed (max.)	rpm	8000	8000	8000	8000	8000
Integrated blade in X, diameter	mm	125	125	125	125	125
Integrated blade rotation speed (max.)	rpm	10000	10000	10000	10000	10000
<b>INSTALLATION</b>						
Exhaust air consumption *	m <sup>3</sup> /h	3400/5300	3400/5300	3400/5300	3400/5300	3400/5300
Exhaust air speed	m/sec	30	30	30	30	30
Exhaust outlet diameter	mm	200/250	200/250	200/250	200/250	200/250
Vacuum management 50 Hz	no. pumps (up to)	4	4	4	4	4
Vacuum management	m <sup>3</sup> /h	250	250	250	250	250

\* stand alone/with pusher



### THE USE OF POWER ONLY WHEN IT IS REQUIRED

SavEnergy allows making things operate only when they are really necessary. It means the machine automatically enters "stand-by" mode when there are no panels to be machined.

Maximum noise levels measured according to the operating conditions established by EN 848-3:2012  
Acoustic pressure in process (routing) 83 dbA (measured according to EN ISO 11202:2010, uncertainty K = 4 dB)  
Acoustic power in process (routing) 102 dbA measured according to EN ISO 3746:2010, uncertainty K = 4 dB)

Even if there is a correlation between above mentioned "conventional" noise emission values and average levels of personal exposure over eight hours of operators, these last also depend on the real operating conditions, duration of exposure, acoustic conditions of the working environment and presence of further noise sources, this means the number of machines and other adjacent processes.

**COMPANY WITH  
QUALITY SYSTEM  
CERTIFIED BY DNV GL  
= ISO 9001 =**

*The technical data can vary according to the requested machine composition. In this catalogue, machines are shown with options. The company reserves the right to modify technical specifications without prior notice; the modifications do not influence the safety foreseen by the CE Norms.*



# PROMPT AND EXPERT TECHNICAL SUPPORT THROUGH A NETWORK OF 1000 TECHNICIANS AND AN INVENTORY OF 36,000 SPARE PARTS.

HIGHLY SPECIALISED TECHNICIANS, EFFICIENT MANAGEMENT AND 6 SPARE PARTS BRANCHES AROUND THE WORLD GUARANTEE A CLOSE, SAFE AND EFFECTIVE TECHNICAL SUPPORT.

## SERVICE

SCM provides a service that goes beyond the purchase, to guarantee the long term performance of your technological production system and peace of mind for your business.

### A COMPLETE RANGE OF AFTER-SALES SERVICES

- installation and start-up of machines, cells, lines and systems
- tailored training programs
- telephone support to reduce times and costs when machines are not working
- preventive maintenance programs to guarantee long term performance
- complete renovation of machines and plants to renew the added value of the investments
- custom upgrading to update machines and plants and meet new production requirements

## SPARE PARTS

SCM Group can count on 140 spare parts professionals worldwide to meet any request with real time shipments.



### 36,000 SPARE PARTS

Our spare parts inventory, with a value of 12 million euros, covers every single machine



### SPARE PARTS GUARANTEED

We guarantee also hard to find parts, with 3,5 million euros invested in "critical" spare parts.



### IMMEDIATE AVAILABILITY

Over 90% of orders received are carried out the same day thanks to the huge inventory available.



### 6 BRANCHES AROUND THE WORLD

The spare parts service can count on worldwide support (Rimini, Singapore, Shenzhen, Moscow, Atlanta, São Bento do Sul)



### 500 SHIPMENTS A DAY

# THE STRONGEST WOOD TECHNOLOGIES ARE IN OUR DNA

## SCM. A HERITAGE OF SKILLS IN A UNIQUE BRAND

Over 65 years of success gives SCM the centre stage in woodworking technology. This heritage results from bringing together the best know-how in machining and systems for wood-based manufacturing. SCM is present all over the world, brought to you by the widest distribution network in the industry.

65 years history

3 main production sites in Italy

300.000 square metres of production space

20.000 machines manufactured per year

90% export

20 foreign branches

400 agents and dealers

500 support technicians

500 registered patents

In SCM's DNA also strength and solidity of a great Group. The SCM Group is a world leader, manufacturing industrial equipment and components for machining the widest range of materials.

## SCM GROUP, A HIGHLY SKILLED TEAM EXPERT IN INDUSTRIAL MACHINES AND COMPONENTS

### INDUSTRIAL MACHINERY

Stand-alone machines, integrated systems and services dedicated to processing a wide range of materials.



WOODWORKING TECHNOLOGIES



TECHNOLOGIES FOR PROCESSING COMPOSITE MATERIALS, ALUMINIUM, PLASTIC, GLASS, STONE, METAL

### INDUSTRIAL COMPONENTS

Technological components for the Group's machines and systems, for those of third-parties and the machinery industry.



SPINDLES AND TECHNOLOGICAL COMPONENTS



ELECTRIC PANELS



METALWORK



CAST IRON

