

# MULTIPOWER

The modern powerintensifier with pneumatic travel stroke and automatically activated pneumohydraulic powerstroke.

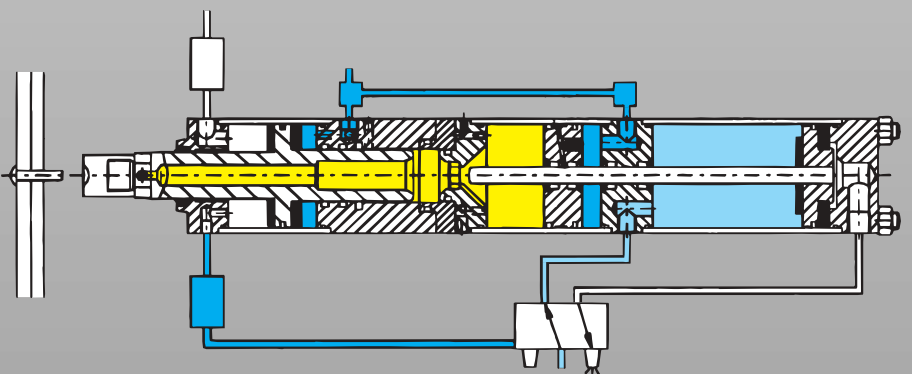

**Forces:** 3 – 1000 kN  
(0,3 – 100 t)



# MULTIPOWER

## Advantages:

- Operates only with air, without hydraulic power units
- High travel stroke force, because of pressure applied to the working- and adjustment piston
- Fast, air-operated approach stroke and return stroke
- Automatic change-over from approach stroke to power stroke
- High stroke frequency, depending on the stroke length
- Absolute air / oil separation for trouble-free operation
- Compact cylinder design, which can be used in any mounting position
- **No spring inside of the cylinder which will be compressed and released during each operation cycle. Springs applied with high stroke frequencies have a limited life expectation and will destroy the cylinder when breaking.**

## and therefore:

- No counter force onto the intensifier piston during the power stroke
- Function of the cylinder already with 2 bars
- Continuous pressure onto the intensifier piston during the return stroke, pressure and speed adjustable
- Highest life expectation of the cylinder. Hydraulic and pneumatic seals from leading manufacturers
- Minimal air consumption through MULTIPOWER standard controls
- Return stroke of intensifier piston achieved only with 2 bars air pressure

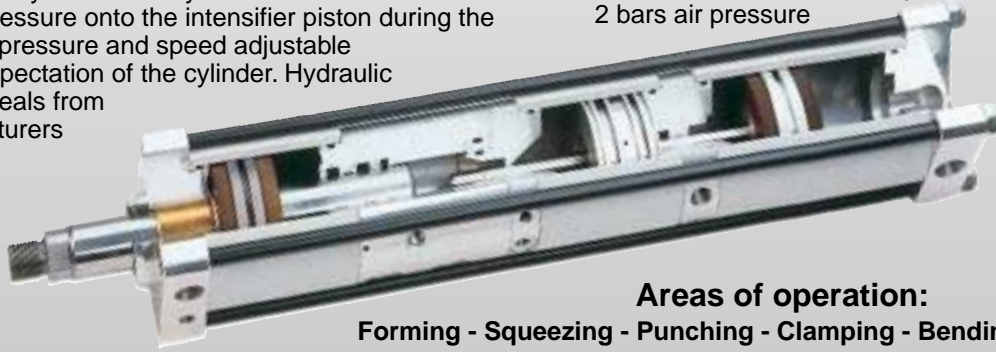

## Areas of operation:

Forming - Squeezing - Punching - Clamping - Bending - Spot-welding

## Sequence of operations:

Connection point 4-V1 pressure admitted, connection point 2-V1 vented, working piston and the adjustment piston extend with low force and with high speed. Due to the impact pressure via 2.1-V1 valve V2 is held in its initial position. Valve V1, supplied from customer, here not displayed.

The working piston hits resistance and the impact pressure is released via throttle D2. Valve V2 switches over. The intensifier piston passes through the high pressure seal and divides the hydraulic connection between adjustment piston and working piston.

Pressure or power intensification takes place. Compared to the intensifier piston, the working piston moves out with increased force, reduced speed, and reduced stroke length (power stroke).

Connection point 2-V1 is pressure admitted. Connection point 4-V1 is vented. Due to the applied pressure on 2.1-V1, valve V2 switches over and connection point 4-V2 is pressure admitted. Working piston and intensifier piston move fast towards their initial position at the same time. As soon as the intensifier piston opens the hydraulic connection between the working piston and the adjustment piston, the adjustment piston is oil pressure admitted and moves together with the working piston back to their initial position.

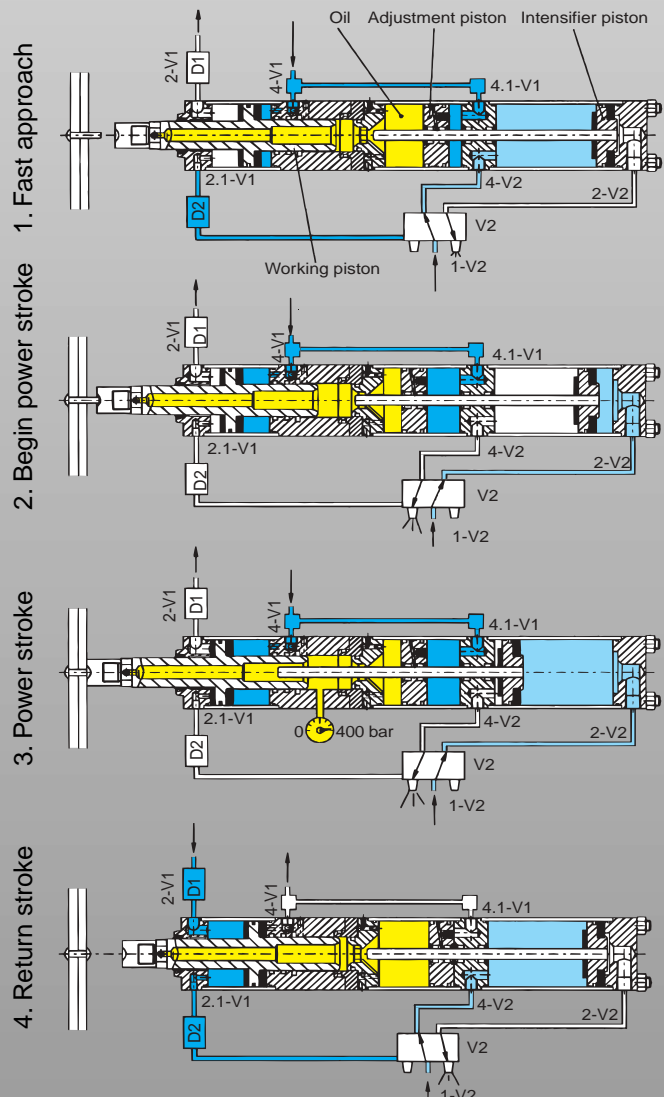

Diagram, valid for all types and sizes

- Versions
- 10-bar-version
  - 8-bar-version
  - 6-bar-version

signifies:

100 % of the rated force (F power stroke) at:

- 10-bar-air pressure
- 8-bar-air pressure
- 6-bar-air pressure

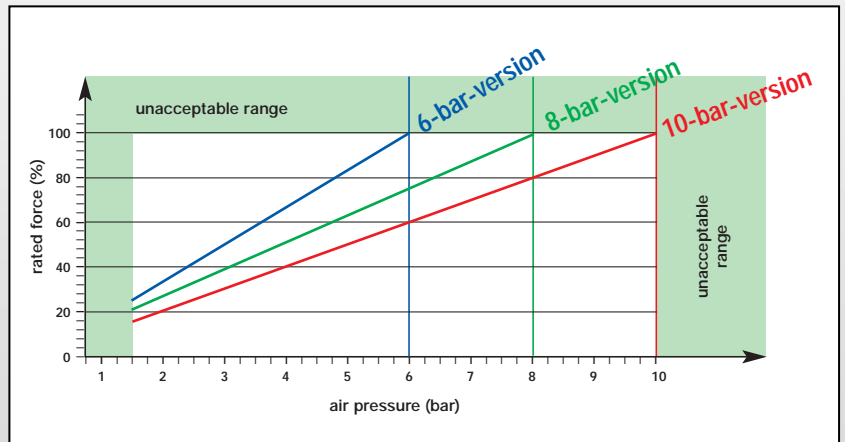

## Declaration of forces for MULTIPOWER type G:

	cylinder-size	not dependent on stroke length	power stroke length 0 – 12 mm	power stroke length 13 – 24 mm	power stroke length 25 – 44 mm
<b>10-bar version</b>	<b>at 10 bar air pressure</b>				
		<b>F<sub>approach stroke</sub></b> kN	<b>F<sub>return stroke</sub></b> kN	<b>F<sub>power stroke</sub></b> kN	<b>F<sub>power stroke</sub></b> kN
	G 20	2,65	2,52	21,1	20,8
	G 40	3,75	3,34	41,2	41,2
	G 60	4,82	4,24	59,9	(*) 62,9
	G 80	6,67	5,63	78,9	82,5
	G 150	10,43	9,27	151,8	160,2
	G 300	17,08	15,87	319,7	292,5
G 500	21,62	20,09	498,5	471,8	
G 750	32,29	27,13	736,6		
G 1000	41,70	37,09	975,1		
<b>8-bar version</b>	<b>at 8 bar air pressure</b>				
		<b>F<sub>approach stroke</sub></b> kN	<b>F<sub>return stroke</sub></b> kN	<b>F<sub>power stroke</sub></b> kN	<b>F<sub>power stroke</sub></b> kN
	G 20	2,12	2,02	20,2	20,9
	G 40	3,00	2,67	(**) 43,1	39,7
	G 60	3,86	3,39	63,6	(**) 62,7
	G 80	5,34	4,51	80,3	83,1
	G 150	8,34	7,42	147,0	157,6
	G 300	13,67	12,70	324,4	290,8
G 500	17,30	16,07	492,7	459,0	
G 750	25,84	21,70	734,8		
G 1000	33,36	29,67	949,2		
<b>6-bar version</b>	<b>at 6 bar air pressure</b>				
		<b>F<sub>approach stroke</sub></b> kN	<b>F<sub>return stroke</sub></b> kN	<b>F<sub>power stroke</sub></b> kN	<b>F<sub>power stroke</sub></b> kN
	G 20	1,59	1,51	18,6	20,6
	G 40	2,25	2,00	41,7	36,9
	G 60	2,89	2,54	(***) 61,4	59,6
	G 80	4,00	3,38	80,0	74,0
	G 150	6,26	5,56	137,0	149,8
	G 300	10,25	9,52	290,0	279,9
G 500	12,97	12,05	470,2	487,5	
G 750	19,38	16,28	709,4		
G 1000	25,02	22,25	1008,9		

According to the diagram the force in the power stroke, the approach stroke and the return stroke is linear to the input air pressure.

Example:

cylinder, 10 bar version, size G 150 with a power stroke length of 10 mm

at 10 bar air pressure: 151,8 kN force

at 1 bar air pressure: 15,18 kN force

at 6 bar air pressure: 91,1 kN force

that means:

\*) at a maximum air pressure of 9,5 bar

\*\*) at a maximum air pressure of 7,5 bar

\*\*\*) at a maximum air pressure of 5,5 bar

# MULTIPOWER

# Type G

Force in the power stroke: up to 1000 kN

Total stroke limitation: not possible

Power stroke limitation: possible

Total stroke: up to 400 mm (16")

Power stroke in retract stroke: not possible

## Power stroke 1 – 12 mm

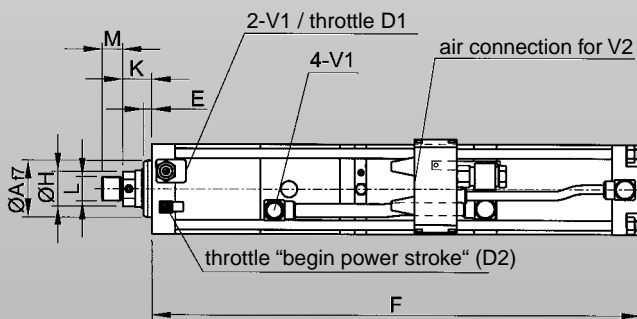
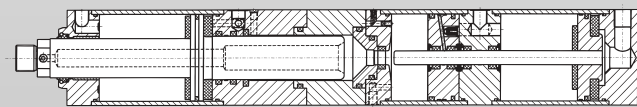

Measurements of MULTIPOWER head piece:  
G 20 up to G 300    G 500    up to G 750

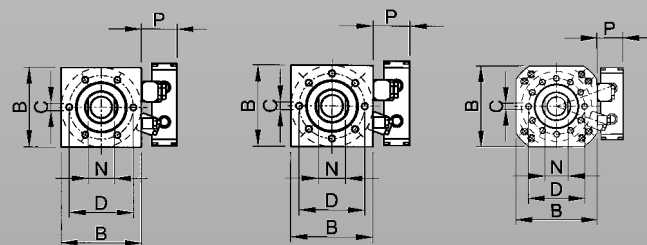

## Power stroke 13 – 80 mm

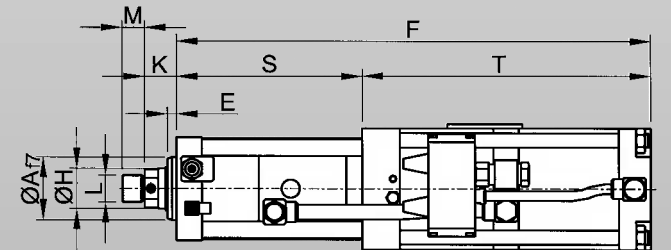
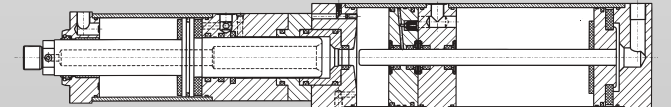
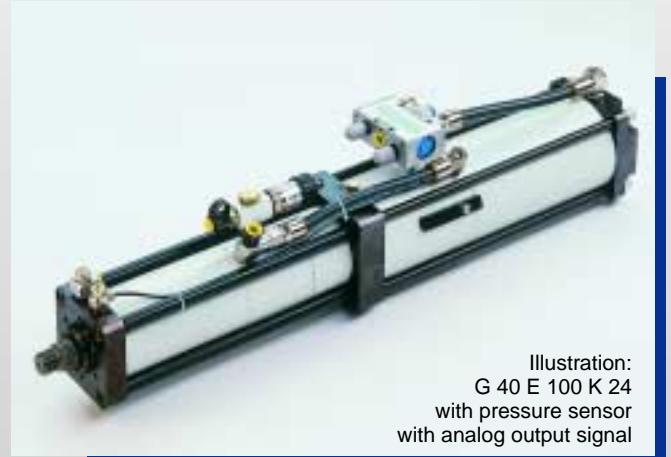

Measurements of MULTIPOWER head piece:  
G 20 up to G 300    G 500

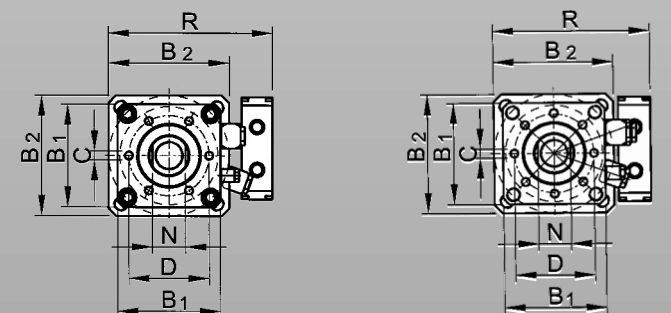

size force in kN	Af7	B	C	D	E	ØH	K	L	M	N	P	power stroke 13 – 28 mm			power stroke 30 – 44 mm		
												B1	B2	R	B1	B2	R
G 20	40	70	6 x M8 x 12	54	10	20	26	M16x1,5	15	17	45	75	85	130	75	110	170
G 40	50	85	6 x M8 x 15	64	10	30	28,5	M22x2	20	24	45	95	110	170	95	135	195
G 60	60	100	6 x M10 x 16	78	10	35	28,5	M24x2	20	30	60	105	135	195	105	170	255
G 80	70	110	6 x M10 x 16	88	10	45	35	M30x2	25	36	60	115	135	195	115	170	255
G 150	75	135	6 x M16 x 25	100	15	50	36	M30x2	25	41	60	140	170	255	140	190	275
G 300	100	175	6 x M20 x 30	132	13	56	42	M39x2	35	50	85	190	190	275	190	270	355
G 500	115	200	8 x M20 x 30	150	25	63	52	M42x2	40	55	85	datas on request					
G 750	150	270	12 x M24 x 40	200	25	100	60	M64x2	60	85	85						
G 1000	150	320	12 x M24 x 40	200	25	100	60	M64x2	60	85	85						

The length of the cylinders (measurements F, S and T) are depending on the stroke length. Please ask for our detailed data sheets.

# MULTIPOWER

# Type U

Force in the power stroke: up to 1000 kN

Total stroke: up to 500 mm (20")

Total stroke limitation: possible  
 Power stroke limitation: not possible  
 Power stroke in retract stroke: possible



Illustration:  
U 80 E 50 K 6

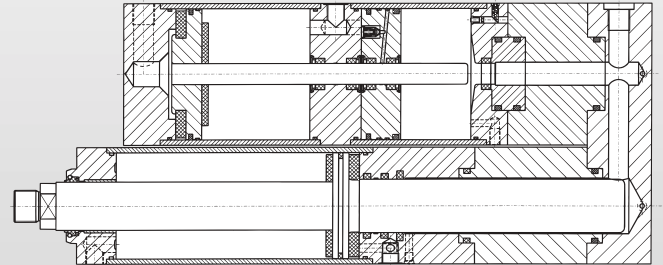

## Power stroke 1 – 12 mm

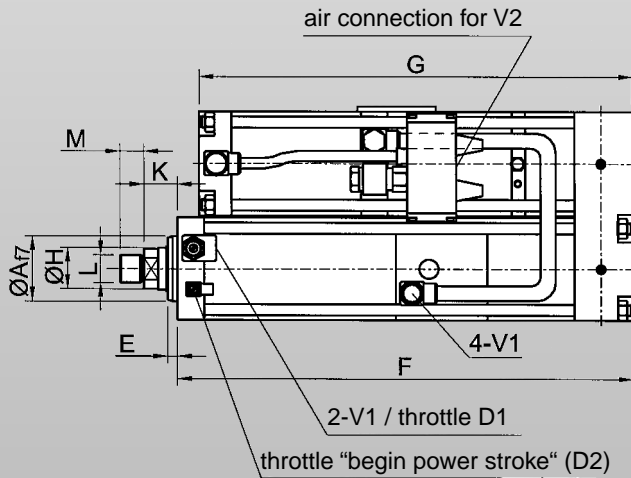

## Power stroke 13 – 80 mm

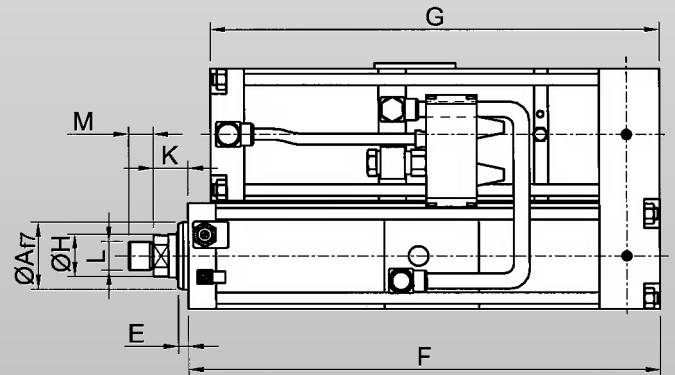

## Measurements of MULTIPOWER head piece: U 20 up to U 300 U 500

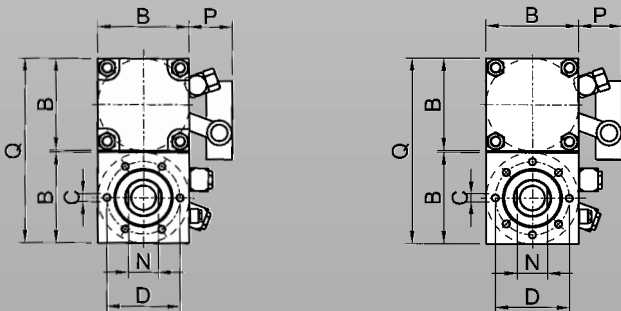

## Measurements of MULTIPOWER head piece: U 10 up to U 300 U 500

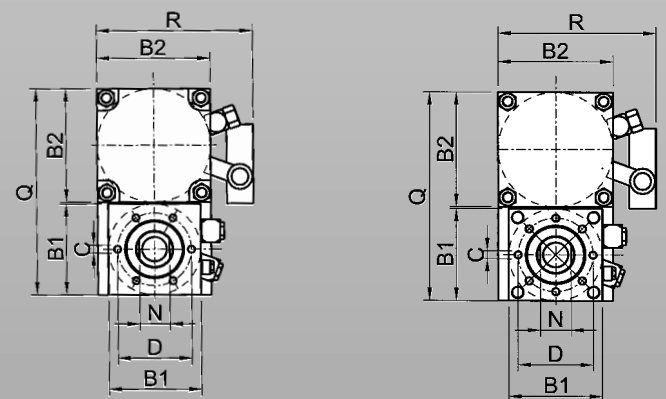

size force in kN	Af7	B	C	D	E	ØH	K	L	M	N	Power stroke 1–12 mm		Power stroke 13 – 28 mm				Power stroke 30 – 44 mm			
											Q	P	B1	B2	Q	R	B1	B2	Q	R
U 10	30	(*)	6 x M6 x 11	40	10	16	24	M12x1,5	15	14			50	70	122	115	50	85	137	130
U 20	40	70	6 x M8 x 12	54	10	20	26	M16x1,5	15	17	142	45	70	85	162	130	70	110	187	170
U 40	50	85	6 x M8 x 15	64	10	30	28,5	M22x2	20	24	172	45	85	110	197	170	85	135	222	195
U 60	60	100	6 x M10 x 16	78	10	35	28,5	M24x2	20	30	202	60	100	135	237	195	100	175	278	260
U 80	70	110	6 x M16 x 16	88	10	45	35	M30x2	25	36	222	60	110	135	248	195	110	175	288	260
U 150	75	135	6 x M16 x 25	100	15	50	36	M30x2	25	41	274	60	135	175	314	260	135	200	339	285
U 300	100	175	6 x M20 x 30	132	13	56	42	M39x2	35	50	354	85	175	200	379	285				
U 500	115	200	8 x M20 x 30	150	25	63	52	M42x2	40	55	404	85								
U 750	150	270	12 x M24 x 40	200	25	100	60	M64x2	60	85										
U 1000	150	320	12 x M24 x 40	200	25	100	60	M64x2	60	85										

datas on request

\*) At the cylinder U 10 the measurements B1, B2, Q and R are valid for a power stroke range from 1 to 28 mm.

The length of the cylinders (measurements F and G) are depending on the stroke length. Please ask for our detailed data sheets.

# MULTIPOWER

## Type E / Z

Force in the power stroke: up to 1000 kN

Total stroke limitation: possible

Power stroke: up to 500 mm (20")

Power stroke limitation: possible

Power stroke in retract stroke: possible

### Type E

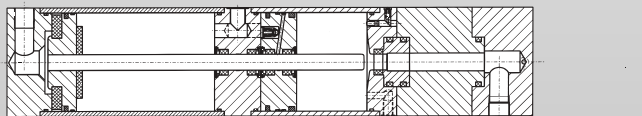

Connection between the working part and the intensifier part with a hydraulic hose (standard length 600 mm) or with solid tubes.

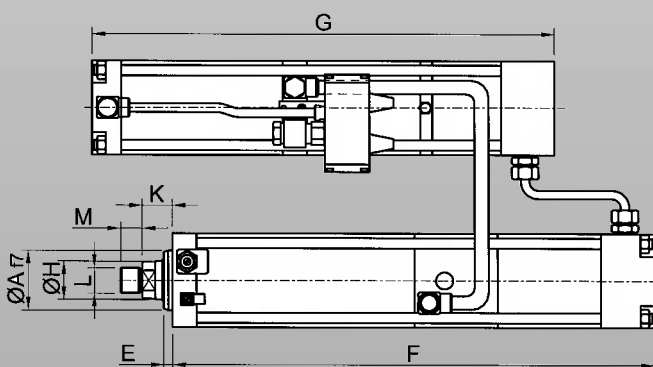
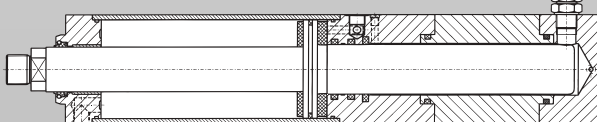

### Type Z

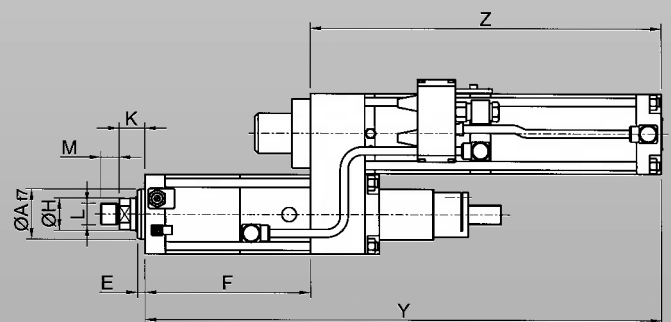
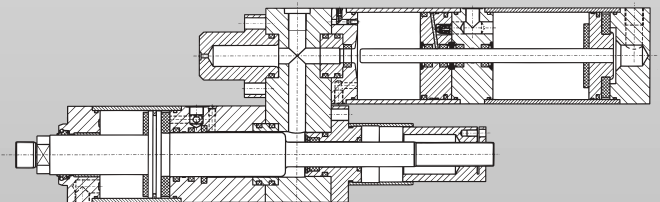
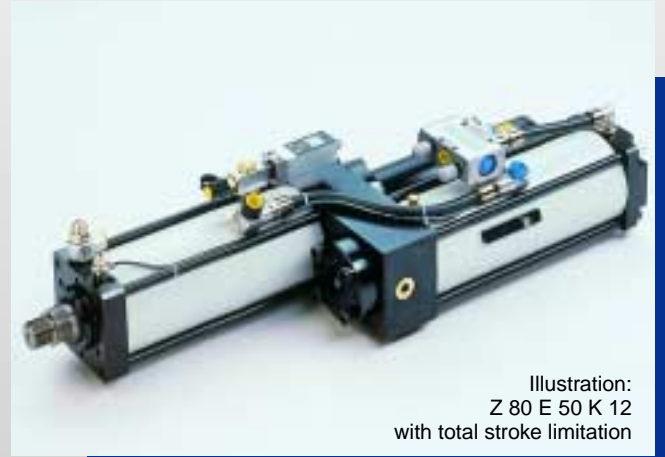

The measurements of the MULTIPOWER head piece are according to the mentioned data's of version G or U.

size force in kN	Af7	E	ØH	K	L	M
E 20	40	10	20	26	M16x1,5	15
E 40	50	10	30	28,5	M22x2	20
E 60	60	10	35	28,5	M24x2	20
E 80	70	10	45	35	M30x2	25
E 150	75	15	50	36	M30x2	25
E 300	100	13	56	42	M39x2	35
E 500	115	25	63	52	M42x2	40
E 750	150	25	100	60	M64x2	60
E 1000	150	25	100	60	M64x2	60

size force in kN	Af7	E	ØH	K	L	M
Z 20	40	10	20	26	M16x1,5	15
Z 40	50	10	30	28,5	M22x2	20
Z 60	60	10	35	28,5	M24x2	20
Z 80	70	10	45	35	M30x2	25
Z 150	75	15	50	36	M30x2	25
Z 300	100	13	56	42	M39x2	35
Z 500	115	25	63	52	M42x2	40
Z 750	150	25	100	60	M64x2	60
Z 1000	150	25	100	60	M64x2	60

The length of the cylinders (measurements F, G, F, Y and Z) are depending on the stroke length. Please ask for our detailed data sheets.

**Please note:**

All mentioned cylinders, controls and presses are under a continued process of development and improvement. Therefore all data's and measurements are subject to technical modifications without notice.

# MULTIPOWER

## CONTROLS (Example connection scheme)

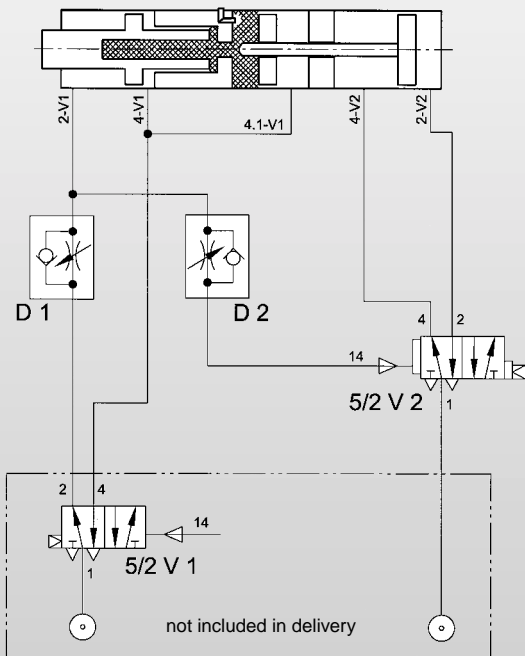

### Legend:

D1 - throttle adjustment approach stroke

D2 - throttle begin power stroke

V1 - 5/2 way valve (not included in delivery)

V2 - 5/2 way valve mounted onto the cylinder and completely connected

### Advantages:

- Force of approach stroke, power stroke and return stroke is adjustable through pressure regulators
- Control of the force in the power stroke is independent to the force of the approach stroke and return stroke
- Speed of approach and return stroke adjustable through throttles
- Force during the power stroke is linear to the input air pressure at connection point 1-V2

### Additional control possibilities:

- Power stroke when stroke length reached
- Power stroke or return stroke after time is reached
- Control with magnetic valves (electrical) for highest stroke frequencies

## PRESS FRAMES / MACHINE FRAMES

The complete design and manufacturing of the press frames including a finite element method calculation is done according to your requirements and specifications especially to control the maximum allowed bending behaviour of the frame. The manufacturing and assembly of the frames is done in house so that all customer requirements can be realised.

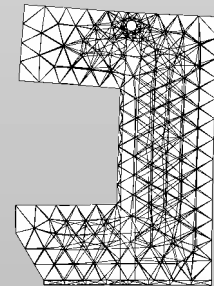

### Specifications

#### ● C-frames,

With or without column guided press plate

as welding construction

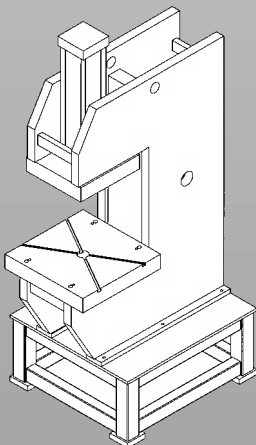

as solid construction

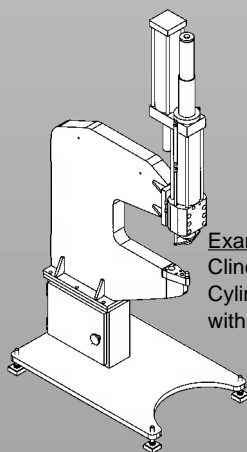

Example:  
Clinch press type CB 080  
Cylinder type: Z 80,  
with total stroke limitation

#### ● 2 and 4 column frames

With or without column guided press plate

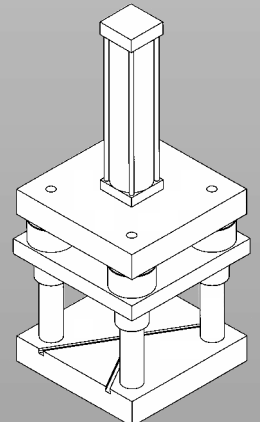
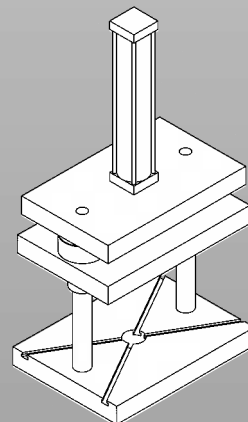

## PRESS SAFETY CONTROLS

For all our presses we can offer a certified 2 hand safety control system according to EU regulations 98/37/EG, attachment IV A9. These certified electrical and pneumatic 2 hand safety controls are available for our C-frames as well as the column frames.

# MULTIPOWER

## OPTIONAL EQUIPMENT AND ATTACHMENTS:

- Tool fixture type W and coupling flange type KF
- Tool fixture with anti rotation device type WV
- Oil level control with optional electrical, pneumatic or acoustic output signal.
- Electronic pressure switch, 0-400 bar with display and optional with distribution piece that the high pressure connector is still available for other controls
- Oil Pressure sensor 0-400 bars with analogue output signal 0-10 volts for a force measurement
- External length measurement system for all MULTIPOWER types possible
- Internal length measurement system for type U, E and Z possible  
Control of the actual position of the working piston is possible over the complete stroke length.  
The measurement range can be selected to the wanted position with a touch of a button on the internal length measurement system.
- **Quality control:**  
Different process controllers are available for a graphical display and documentation of the force-stroke length diagram of every stroke.  
Units are programmed for the attached sensors and completely assembled if wanted.



- Control of the working piston through proximity switches mounted adjustable on the tension rods of the MULTIPOWER cylinders. Signal through an integrated magnetic unit on the working piston. Sensors are available optional for steel cylinder tubes or for stainless steel cylinder tubes.
- Control of the transducer piston with a pressure resistant proximity switch

## BRANDT SYSTEM AB

Hängpilsgatan 5  
426 77 VÄSTRA FRÖLUNDA  
031 - 291090 • 031 - 682449  
E-post: [jonas@brandt-system.se](mailto:jonas@brandt-system.se)