

ETV 400

compact and powerful, the medium seperated lever solenoid valve

Durable, maintenance-free and flexible – that is the ETV 400.

With the use of high-performance plastics, the ETV 400 stands for a high-quality and technically superior valve series. It is perfectly suited for applications in the food sector or in medical technology, as well as for the use of aggressive media such as acids, alkalis and special inks.



ADVANTAGES



Clean and robust

Minimal dead space completely without dirt pockets. The structure is insensitive to solid particles and splash water.



Thermal decoupling

No heat transfer between coil and medium. The medium is hardly heated by the electromagnet.



Flexible and efficient

Possibility of variation due to different coils and high energy efficiency due to user-specific design.



Simply mounted

Easy handling and quick, tool-free assembly thanks to proven AVS Römer push-in technology.



Highest chemical resistance

The separation of magnet system and medium via a separating membrane ensures maximum chemical resistance.



Tailored to your requirements

Variants of the standard products or customized products as the perfect solution for your application.



The AVS Römer MAGMA valve principle

The separating membrane isolates the solenoid system and the medium. When the solenoid coil is actuated, the magnetic force acts on the solenoid armature. The lever connected to it opens the valve seat. The membrane attached to the lever also serves as a valve seal and separates the interior of the valve spatially and thermally from the solenoid system.

The high-quality valve series with coaxial flow or angle flow, in 2/2- and 3/2-way design, is particularly suitable for:

- Food and beverage industry
- Medical and pharmaceutical industry
- Water treatment
- Chemical industry
- Printing industry

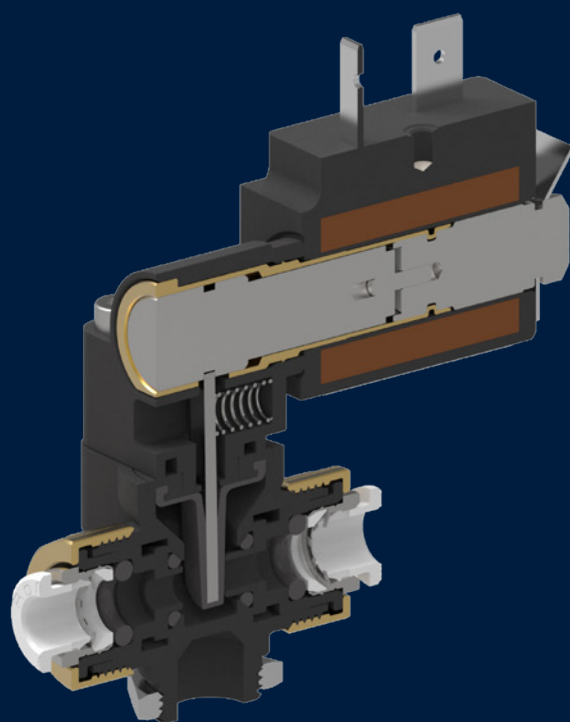

TECHNICAL SPECIFICATIONS

Type	coaxial or angle flow in 2/2- and 3/2-way version	Voltage	24 V DC (further variants available)
Operating temperature	up to 130 °C	Protection class	IP 65, with cable socket dust-tight and protected
Operating pressure	up to 16 bar	Approval	NSF certified, FDA compliant materials
Nominal diameter	1.5 to 4 mm		
Nominal power	8 watt (further variants available)		

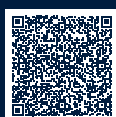

AVS Römer GmbH & Co. KG

Reismühle 3 • 94481 Grafenau • Phone: +49 8552 4076 300
info@avs-roemer.de • www.avs-roemer.de

V2022.04

