

14.08.2024

C70-2

Art. No. 3457

This converter is suitable for the integration into ultrasonic welding machines as well as for special applications.



Specifications

Technical Specifications

Operating Frequency	70 kHz
Amplitude Amplification	Amplified
Cable Length	4.5 m
HF Connection	Lemo 0
Mounting	Directly on the housing

Standards

Safety	- CE
IP Class	IP 20
Standards	- EN 55011 Class A / Group 1 - EN 61000-6-2 - EN 61000-6-4

Dimensions and Weight

Dimensions Detail	Ø 16 mm
-------------------	---------

Weight	0.1 kg
--------	--------

Compatibility / Accessoires

Compatibility	<ul style="list-style-type: none">- HG70-1- HG70-1 without converter
---------------	---

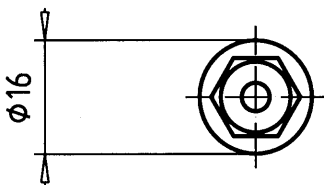
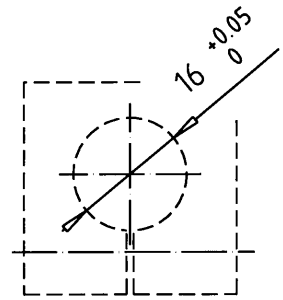
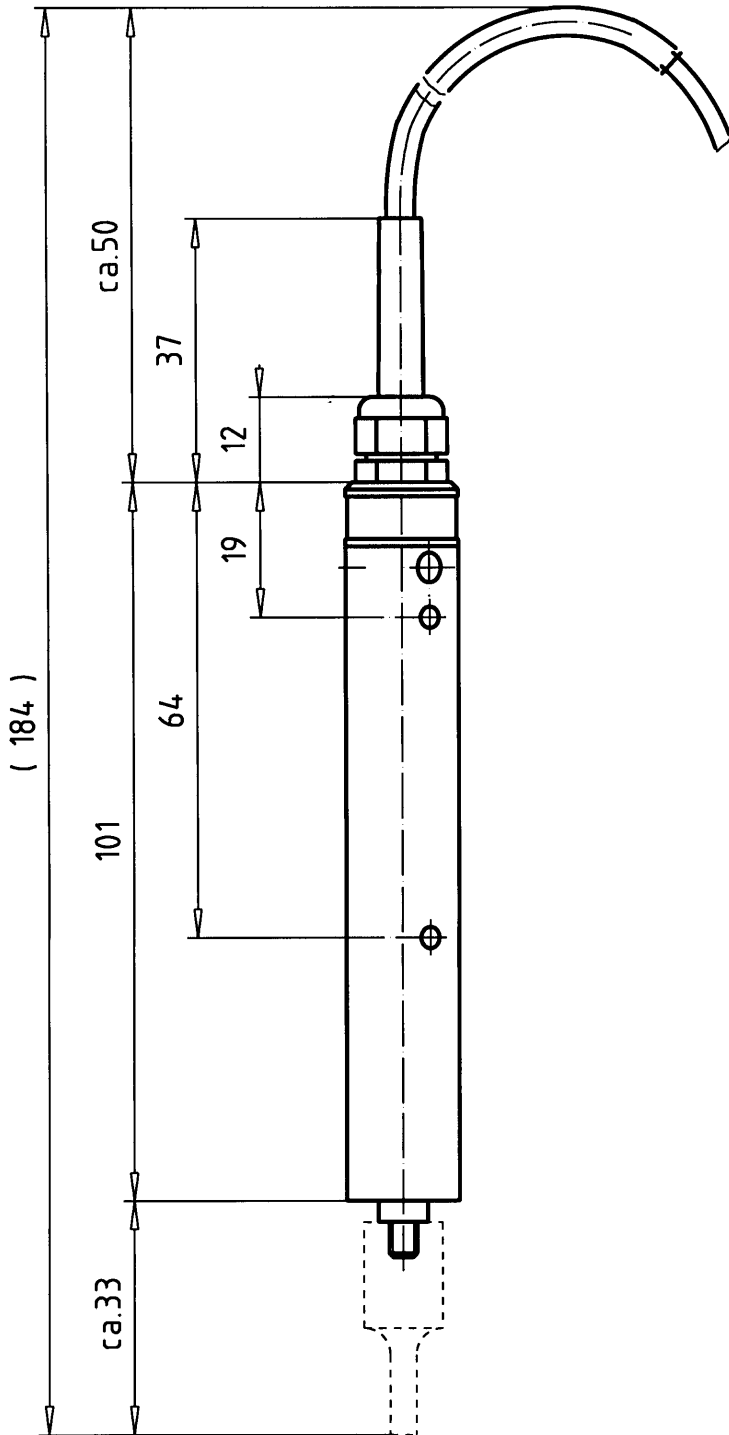

RINCO ULTRASONICS AG		
8590 Romanshorn		
C70-2/5		
d00001412		
DIN A4	1:1	1.03.96 AB