

TYPICAL APPLICATIONS

- Medical equipment - pumps, blowers and electric scooters and wheelchairs
- Automatic door and window openers
- Computer-controlled embroidery machines
- Scanners
- Packaging equipment and printing products
- HVAC equipment (air handling)
- Robotic tape storage and retrieval
- Semiconductor handling and insertion machines
- Actuators

FEATURES

- Inside rotor construction for quick acceleration
- 8 pole motor standard, 4 pole motors optional for high speed applications
- Compact size – lengths from 1.3 to 5.5 inches
- Diameter – 1.2 to 4.15 inches
- Continuous torques from 2.4 to 519 oz-in
- High energy neodymium magnets
- Safe, arcless operation
- High speed capability – up to 20,000 rpm
- High torque per dollar ratio

BENEFITS

- Operation at any single speed - not limited to AC frequency
- Motor life is not limited to brush or commutator life
- An essentially linear speed / torque curve
- Efficient operation without losses associated with brushes and commutation or armature induction
- Precise, variable speed control
- Extremely quiet operation
- Long-life operation

ENCODERS

High resolution, high reliability, and state-of-the-art technology in a small package:

- Bidirectional incremental code
- Up to 1024 cycles standard
- Up to 3 channels: A, B, and index
- TTL / CMOS compatible
- Hewlett Packard HEDS-5500 encoder standard, other configurations and resolutions available

SILENCER BRUSHLESS MOTOR DRIVES

Optimized for use with Silencer Brushless DC motors, these drives provide:

- Multiple operating modes - commutation, velocity, torque, 2 and 4 quadrant
- Feedback using Hall effect sensor or encoder
- Efficient PWM speed control
- CE approved for European applications
- Low cost

Note: This catalog contains basic marketing information and general part descriptions of Moog Components Group product lines. With respect to the U.S. export regulations, the products described herein are controlled by the U.S. Commerce Department or the U.S. State Department. Contact Moog Components Group for additional detail on the export controls that are applicable to your part.

Silencer® Series Brushless DC Motors

Commercial and Industrial

BN12, 17, 23, 28, 34 and 42

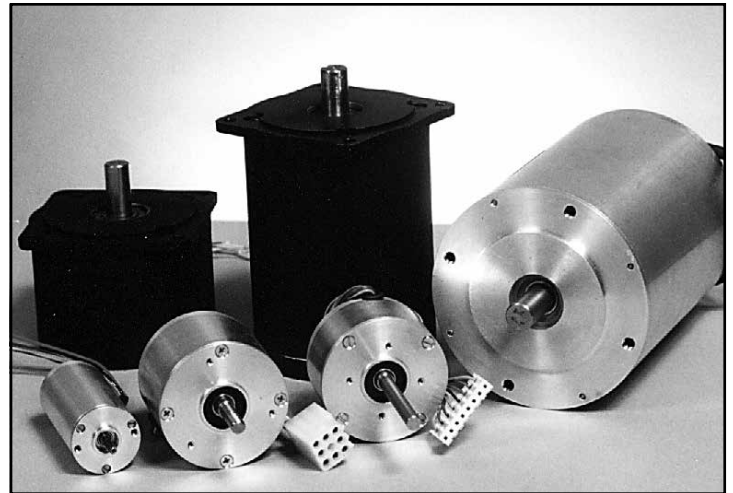

Quiet, Brushless Motors

Silencer® Brushless motors provide smooth, efficient operation and increased speed ranges. Utilizing bonded neo magnets, our BN series motors provide excellent value with their low cost and high torque. Each frame of the BN motors is available in four different lengths with a variety of electrical options to meet a wide range of commercial and industrial operating specifications.

Reliable, Low-Cost Operation

The compact BN motors are well-suited for applications demanding low audible noise and long life. An aluminum housing protects the unit in rugged applications and environments. Typical options include electronic drives, encoders and gearheads, as well as Hall effect, resolver and sensorless feedback.

Our engineering department is available for consultation to help you tailor a brushless motor for your specific application.

SPECIFICATION AND NUMBERING SYSTEM

Part Numbering System Guide

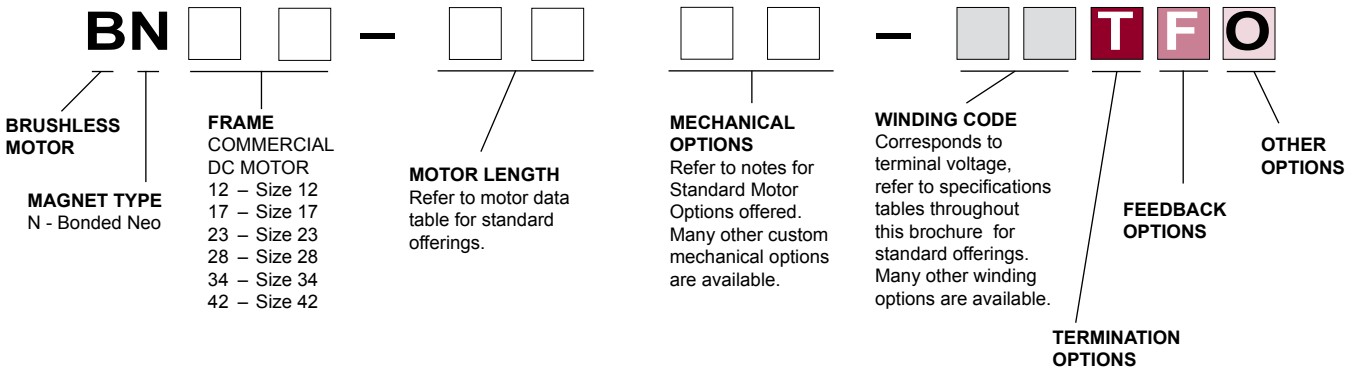

Conversion Table

FROM	TO	MULTIPLY BY
Length		
inches	cm	2.540
feet	cm	30.48
cm	inches	.3937
cm	feet	3.281 x 10 ⁻²
Mass		
oz	g	28.35
lb	g	453.6
g	oz	3.527 x 10 ⁻²
lb	oz	16.0
g	lb	2.205 x 10 ⁻³
oz	lb	6.250 x 10 ⁻²
Torque		
oz-in	Nm	141.61 ⁻¹
oz-in	g-cm	72.01
lb-ft	g-cm	1.383 x 10 ⁴
g-cm	oz-in	1.389 x 10 ⁻²
lb-ft	oz-in	192.0
g-cm	lb-ft	7.233 x 10 ⁻⁵
oz-in	lb-ft	5.208 x 10 ⁻³
Rotation		
rpm	degrees/sec	6.0
rad/sec	degrees/sec	57.30
degrees/sec	rpm	.1667
rad/sec	rpm	9.549
degrees/sec	rad/sec	1.745 x 10 ⁻²
rpm	rad/sec	.1047
Moment Of Inertia		
oz-in ²	g-cm ²	182.9
lb-ft ²	g-cm ²	4.214 x 10 ⁵
g-cm ²	oz-in ²	5.467 x 10 ⁻³
lb-ft ²	oz-in ²	2.304 x 10 ³
g-cm ²	lb-ft ²	2.373 x 10 ⁻⁶
oz-in ²	lb-ft ²	4.340 x 10 ⁻⁴
oz-in-sec ²	g-cm ²	7.062 x 10 ⁴

Timing Diagram for Hall Switches

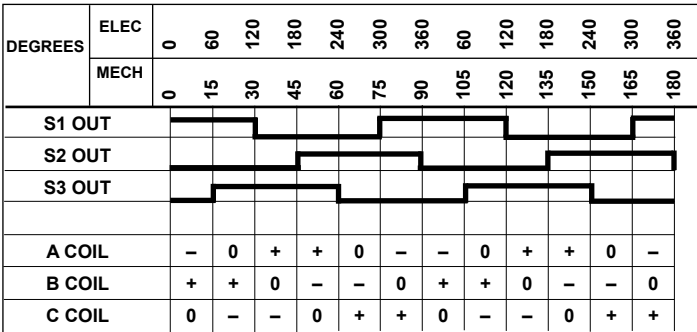

Hall Effect Switches

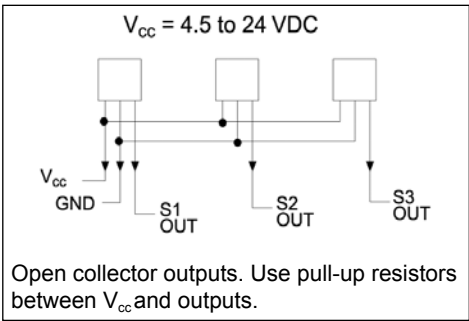

IMPORTANT

The operational life and performance of any motor is dependent upon individual operating parameters, environment, temperature and other factors. Your specific application results may vary. Please consult the factory to discuss your requirements.

Bearing Load Rating (lbs)

Motor Size	Dynamic	Static
BN-12	295	110
BN-17	331	134
BN-23	743	304
BN-28	1022	422
BN-34	1532	683
BN-42	1340	725

BN12 Specifications

BN12 SPECIFICATIONS - Continuous Stall Torque 2.4 - 8.6 oz-in (0.0170 - 0.0607 Nm) Peak Torque 13 - 77 oz-in (0.0918 - 0.5437 Nm)

Part Number*	BN12-13AF- <input type="checkbox"/> <input type="checkbox"/> <input type="checkbox"/> <input type="checkbox"/> <input type="checkbox"/>			BN12-18AF- <input type="checkbox"/> <input type="checkbox"/> <input type="checkbox"/> <input type="checkbox"/> <input type="checkbox"/>			BN12-23AF- <input type="checkbox"/> <input type="checkbox"/> <input type="checkbox"/> <input type="checkbox"/> <input type="checkbox"/>			BN12-28AF- <input type="checkbox"/> <input type="checkbox"/> <input type="checkbox"/> <input type="checkbox"/> <input type="checkbox"/>					
	01	02	03	01	02	03	01	02	03	01	02	03			
Winding Code**															
	L = Length	inches			1.30			1.80			2.30			2.80	
	millimeters			33.02			45.72			58.42			71.12		
Terminal Voltage	volts DC	12.0	24.0	36.0	12.0	24.0	36.0	12.0	24.0	36.0	12.0	24.0	36.0		
Peak Torque	oz-in	13.0	13.0	14.0	37.0	37.0	39.0	58.0	58.0	61.0	77.0	77.0	72.0		
	Nm	0.0918	0.0918	0.0989	0.2613	0.2613	0.2754	0.4096	0.4096	0.4308	0.5437	0.5437	0.5084		
Continuous Stall Torque	oz-in	2.4	2.4	2.4	4.9	5.0	5.0	6.9	6.9	6.9	8.3	8.6	8.6		
	Nm	0.0169	0.0169	0.0169	0.0346	0.0353	0.0353	0.0487	0.0487	0.0487	0.0586	0.0607	0.0607		
Rated Speed	RPM	13027.0	12736.0	13753.0	11928.0	11448.0	12320.0	10604.0	10601.0	11489.0	11036.0	10253.0	9529.0		
	rad/sec	1364	1334	1440	1249	1199	1290	1110	1110	1203	1156	1074	998		
Rated Torque	oz-in	1.8	1.8	1.8	3.5	3.6	3.5	5.0	5.0	4.7	5.4	5.9	6.2		
	Nm	0.0127	0.0127	0.0127	0.0247	0.0254	0.0247	0.0353	0.0353	0.0332	0.0381	0.0417	0.0438		
Rated Current	Amps	2.26	1.13	0.77	3.49	1.76	1.20	4.32	2.16	1.46	4.81	2.46	1.61		
Rated Power	watts	17.3	17.0	18.3	30.9	30.5	31.9	39.2	39.2	39.9	44.1	44.7	43.7		
Torque Sensitivity	oz-in/amp	1.02	2.06	2.95	1.24	2.56	3.64	1.42	2.84	4.01	1.41	2.99	4.75		
	Nm/amp	0.0072	0.0145	0.0208	0.0088	0.0181	0.0257	0.0100	0.0201	0.0283	0.0100	0.0211	0.0335		
Back EMF	volts/KRPM	0.75	1.53	2.18	0.92	1.89	2.69	1.05	2.10	2.96	1.04	2.21	3.51		
	volts/rad/sec	0.0072	0.0145	0.0208	0.0088	0.0181	0.0257	0.0100	0.0201	0.0283	0.0100	0.0211	0.0335		
Terminal Resistance	ohms	0.953	3.89	7.85	0.403	1.67	3.36	0.294	1.18	2.36	0.219	0.934	2.36		
Terminal Inductance	mH	0.254	1.100	2.210	0.181	0.742	1.460	0.172	0.692	1.374	0.128	0.447	1.220		
Motor Constant	oz-in/sq.rt.watt	1.04	1.04	1.05	1.95	1.98	1.99	2.62	2.61	2.61	3.01	3.09	3.09		
	Nm/sq.rt.watt	0.00738	0.00738	0.00744	0.01379	0.01399	0.01402	0.01849	0.01846	0.01843	0.02128	0.02185	0.02183		
Rotor Inertia	oz-in-sec ² x10 ⁻³	0.040	0.040	0.040	0.080	0.080	0.080	0.120	0.120	0.120	0.16	0.16	0.16		
	g-cm ²	2.82	2.82	2.82	5.65	5.65	5.65	8.47	8.47	8.47	11.3	11.3	11.3		
Weight	oz	3.6	3.6	3.6	5.5	5.5	5.5	7.3	7.3	7.3	9.1	9.2	9.2		
	g	102.2	102.2	102.2	156.2	156.2	156.2	207.3	207.3	207.3	258.4	261.3	261.3		
# of Poles		8.0	8.0	8.0	8.0	8.0	8.0	8.0	8.0	8.0	8.0	8.0	8.0		
Timing		120°	120°	120°	120°	120°	120°	120°	120°	120°	120°	120°	120°		
Mech. Time Constant	ms	5.2	5.2	5.1	3.0	2.9	2.9	2.5	2.5	2.5	2.5	2.4	2.4		
Electrical Time Constant	ms	0.14	0.14	0.14	0.24	0.25	0.25	0.29	0.29	0.29	0.29	0.31	0.31		
Thermal Resistivity	deg. C/watt	10.7	10.3	11.2	9.5	8.9	9.3	8.3	8.3	8.3	7.7	7.3	7.4		
Speed/Torque Gradient	rpm/oz-in	1245.8	1234.2	1220.6	353.3	345.2	343.2	197.2	197.9	198.8	149.3	141.3	141.6		

- Notes:
- Motor mounted to a 4 x 4 x 1/4 inches aluminum plate, still air.
 - Maximum winding temperature of 155°C.
 - Typical electrical specifications at 25°C.
 - Motor Terminal Voltages are representative only; motors may be operated at voltages other than those listed in the table. For assistance please contact our applications engineer.
 - For MS (military style) connector, please specify connector housing and terminal.
 - Data for informational purposes only. Should not be considered a binding performance agreement. For specific applications, please contact the factory.

*Many other custom mechanical options are available – consult factory.
**Many other winding options are available – consult factory.

Select your options below and place their code in its corresponding block as shown on page 5.

- | | | |
|--------------------------------------|---|--|
| <input type="checkbox"/> TERMINATION | <input type="checkbox"/> FEEDBACK OPTIONS | <input type="checkbox"/> OTHER OPTIONS |
| L – Leads (std) | H – Hall Effect (std) | D – Drive |
| C – Connector | R – Resolver | E – Encoder |
| M – MS connector | S – Sensorless | G – Gearhead |

BN12 Typical Outline

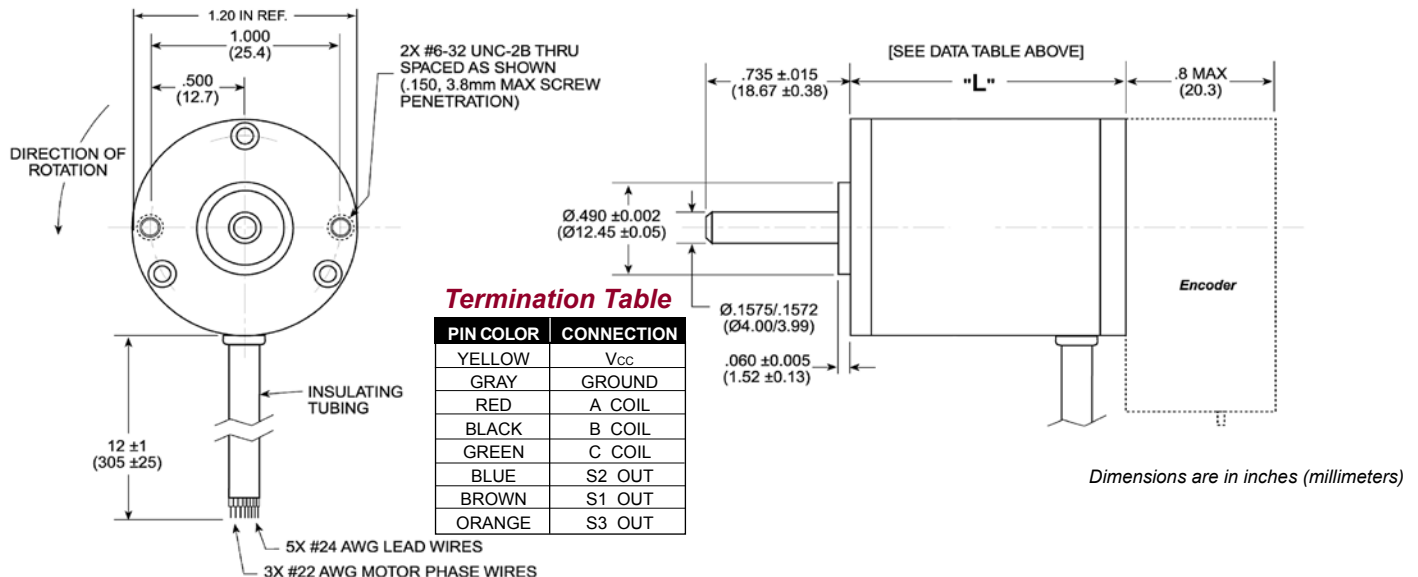

BN12 Performance Curves

BN12 Performance Curves

BN12-13AF-01: Continuous & Intermittent Operation at 12 Volt DC

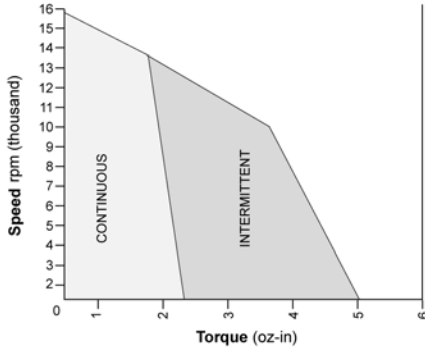

BN12-13AF-02: Continuous & Intermittent Operation at 24 Volt DC

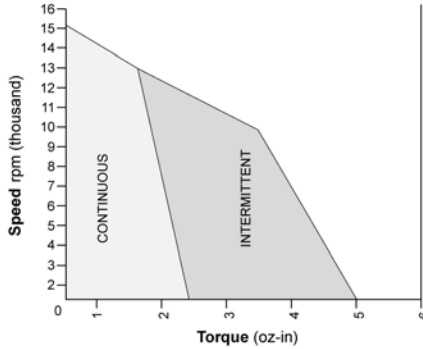

BN12-13AF-03: Continuous & Intermittent Operation at 36 Volt DC

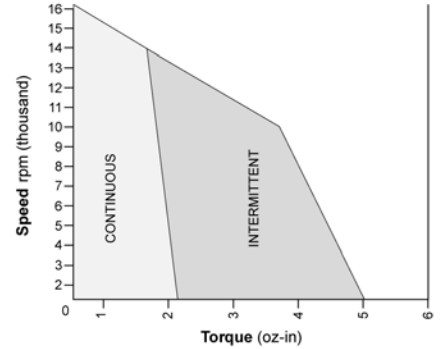

BN12-18AF-01: Continuous & Intermittent Operation at 12 Volt DC

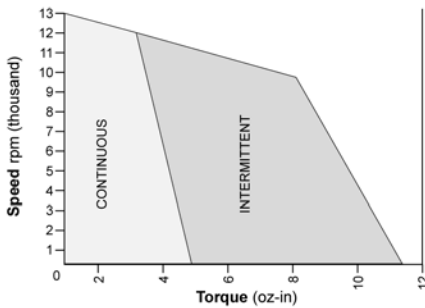

BN12-18AF-02: Continuous & Intermittent Operation at 24 Volt DC

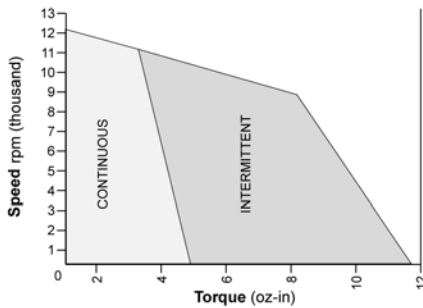

BN12-18AF-03: Continuous & Intermittent Operation at 36 Volt DC

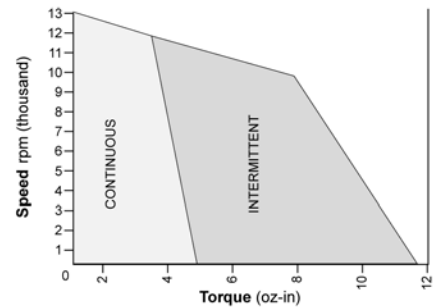

BN12-23AF-01: Continuous & Intermittent Operation at 12 Volt DC

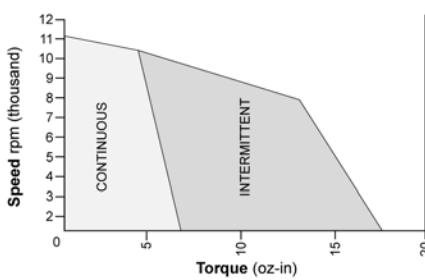

BN12-23AF-02: Continuous & Intermittent Operation at 24 Volt DC

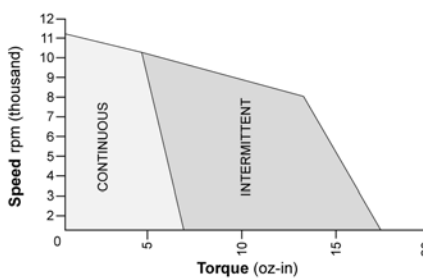

BN12-23AF-03: Continuous & Intermittent Operation at 36 Volt DC

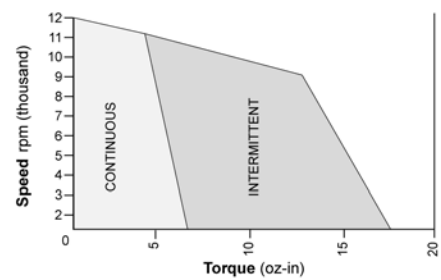

BN12-28AF-01: Continuous & Intermittent Operation at 12 Volt DC

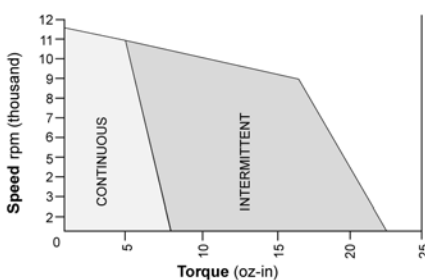

BN12-28AF-02: Continuous & Intermittent Operation at 24 Volt DC

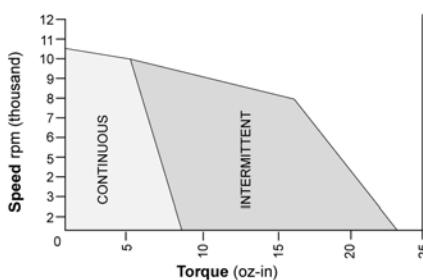

BN12-28AF-03: Continuous & Intermittent Operation at 36 Volt DC

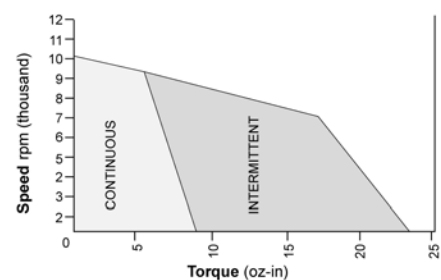

Note: Intermittent operation is based on a 20% duty cycle of one minute on, four minutes off.
Please contact the factory regarding the duty cycle of your application.

BN12 EU Specifications

Inside Rotor
Brushless Motors

BN12 EU SPECIFICATIONS -

Continuous Stall Torque 2.4 - 8.6 oz-in (0.0170 - 0.0587 Nm)
Peak Torque 13 - 77 oz-in (0.0918 - 0.544 Nm)

Part Number*		BN12-13EU- <input type="checkbox"/> <input type="checkbox"/> <input type="checkbox"/> <input type="checkbox"/>			BN12-18EU- <input type="checkbox"/> <input type="checkbox"/> <input type="checkbox"/> <input type="checkbox"/>			BN12-23EU- <input type="checkbox"/> <input type="checkbox"/> <input type="checkbox"/> <input type="checkbox"/>			BN12-28EU- <input type="checkbox"/> <input type="checkbox"/> <input type="checkbox"/> <input type="checkbox"/>		
Winding Code**		01	02	03	01	02	03	01	02	03	01	02	03
L = Length	inches	1.30			1.80			2.30			2.80		
	millimeters	33.02			45.72			58.42			71.12		
Terminal Voltage	volts DC	12	24	36	12	24	36	12	24	36	12	24	36
Peak Torque	oz-in	13	13	14	37	37	39	58	58	61	77	77	72
	Nm	0.0918	0.0918	0.0989	0.262	0.262	0.276	0.410	0.410	0.431	0.544	0.544	0.509
Continuous Stall Torque	oz-in	2.4	2.4	2.4	4.9	5.0	5.0	6.9	6.9	6.9	8.3	8.6	8.6
	Nm	0.0170	0.0170	0.0170	0.0346	0.0354	0.0354	0.0488	0.0488	0.0488	0.0587	0.0587	0.0587
Rated Speed	RPM	13027	12736	13753	11928	11448	12320	10604	10601	11489	11036	10253	9529
	rad/sec	1364	1333	1440	1249	1198	1290	1110	1110	1203	1155	1073	997
Rated Torque	oz-in	1.80	1.80	1.80	3.50	3.60	3.50	5.00	5.00	4.70	5.40	5.90	6.20
	Nm	0.0127	0.0127	0.0127	0.0248	0.0255	0.0248	0.0354	0.0354	0.0332	0.0382	0.0417	0.0438
Rated Current	Amps	2.26	1.13	0.77	3.49	1.76	1.20	4.32	2.16	1.46	4.81	2.46	1.61
Rated Power	watts	17.3	17.0	18.3	30.9	30.5	31.9	39.2	39.2	39.9	44.1	44.7	43.7
Torque Sensitivity	oz-in/amp	1.02	2.06	2.95	1.24	2.56	3.64	1.42	2.84	4.01	1.41	2.99	4.75
	Nm/amp	0.0072	0.0146	0.0209	0.0088	0.0180	0.0257	0.0101	0.0201	0.0284	0.0100	0.0212	0.0336
Back EMF	volts/KRPM	0.75	1.53	2.18	0.92	1.89	2.69	1.05	2.10	2.96	1.04	2.21	3.51
	volts/rad/sec	0.0072	0.0146	0.0209	0.0088	0.0180	0.0257	0.0101	0.0201	0.0284	0.0100	0.0212	0.0336
Terminal Resistance	ohms	0.953	3.89	7.85	0.403	1.67	3.36	0.294	1.18	2.36	0.219	0.934	2.36
Terminal Inductance	mH	0.254	1.100	2.210	0.181	0.742	1.460	0.172	0.692	1.374	0.128	0.447	1.220
Motor Constant	oz-in/sq.rt.watt	1.0	1.1	1.1	2.0	2.0	2.0	2.6	2.6	2.6	3.0	3.1	3.1
	Nm/sq.rt.watt	0.0071	0.0078	0.0078	0.0142	0.0142	0.0142	0.0184	0.0184	0.0184	0.0212	0.0219	0.0219
Rotor Inertia	oz-in-sec ²	4.0E-05	4.0E-05	4.0E-05	8.0E-05	8.0E-05	8.0E-05	1.2E-04	1.2E-04	1.2E-04	1.6E-04	1.6E-04	1.6E-04
	g-cm ²	2.83	2.83	2.83	5.65	5.65	5.65	8.48	8.48	8.48	11.3	11.3	11.3
Weight	oz	3.6	3.6	3.6	5.5	5.5	5.5	7.3	7.3	7.3	9.1	9.2	9.2
	g	102	102	102	156	156	156	207	207	207	258	261	261

Notes:

- Motor mounted to a 4 x 4 x 1/4 inches aluminum plate, still air.
- Maximum winding temperature of 155°C.
- Typical electrical specifications at 25°C.
- Motor Terminal Voltages are representative only; motors may be operated at voltages other than those listed in the table. For assistance please contact our applications engineer.
- For MS (military style) connector, please specify connector housing and terminal.
- Data for informational purposes only. Should not be considered a binding performance agreement. For specific applications, please contact the factory.

*Many other custom mechanical options are available – consult factory.

**Many other winding options are available – consult factory.

Select your options below and place their code in its corresponding block as shown on page 5.

- | | | |
|---|--|---|
| <input type="checkbox"/> TERMINATION | <input type="checkbox"/> FEEDBACK OPTIONS | <input type="checkbox"/> OTHER OPTIONS |
| L – Leads (std) | H – Hall Effect (std) | D – Drive |
| C – Connector | R – Resolver | E – Encoder |
| M – MS connector | S – Sensorless | G – Gearhead |

BN12 EU Typical Outline

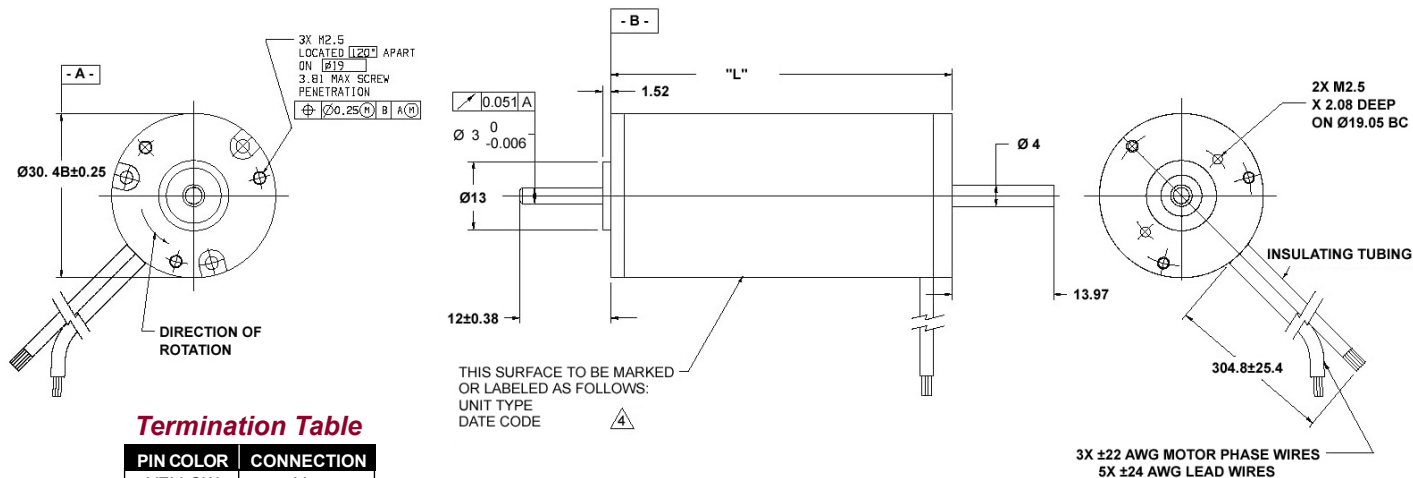

Termination Table

PIN COLOR	CONNECTION
YELLOW	V _{CC}
GRAY	GROUND
RED	A COIL
BLACK	B COIL
GREEN	C COIL
BLUE	S2 OUT
BROWN	S1 OUT
ORANGE	S3 OUT

Dimensions are in millimeters

BN12 EU Performance Curves

BN12 EU Performance Curves

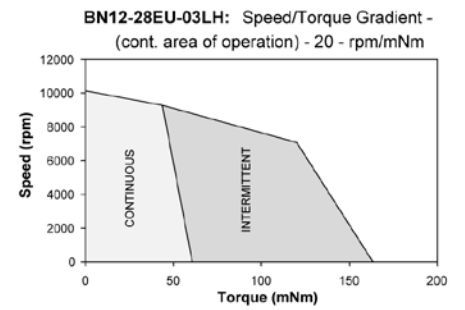
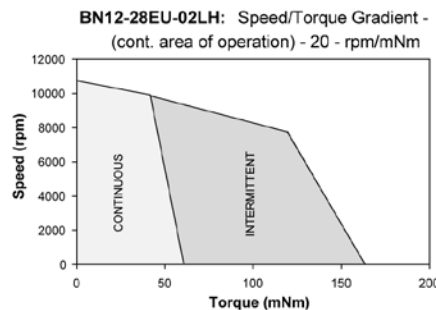
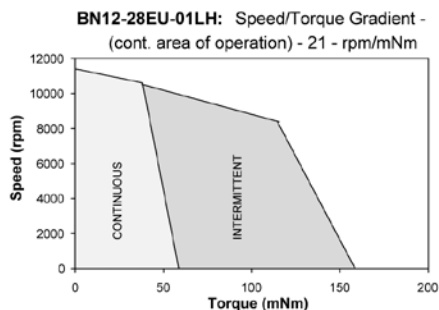
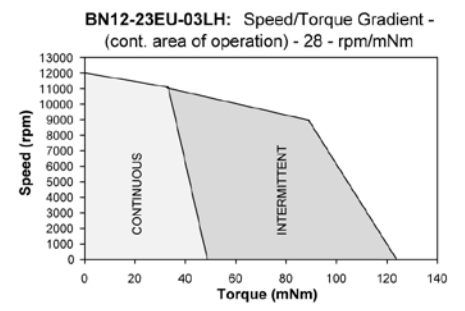
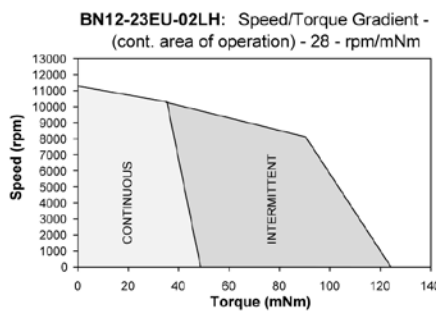
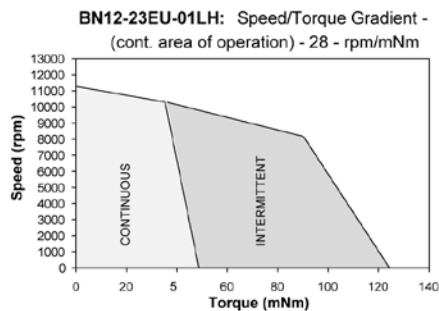
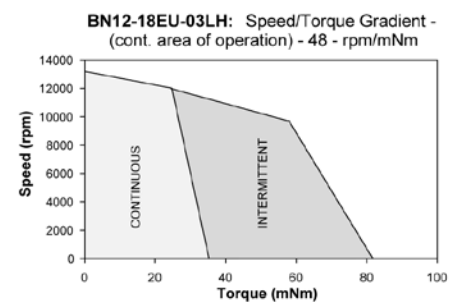
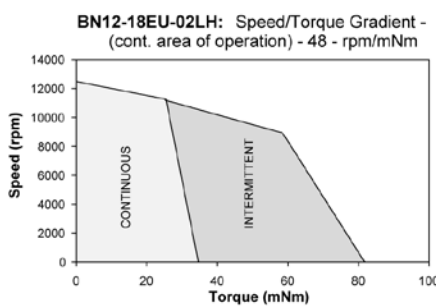
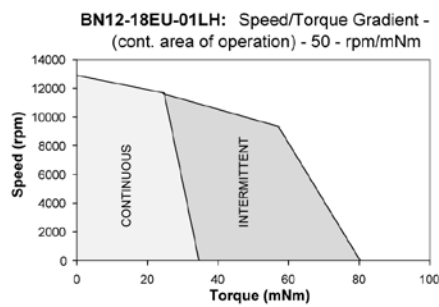
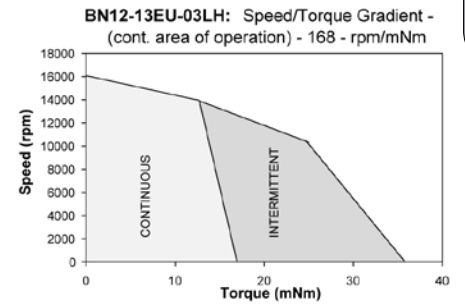
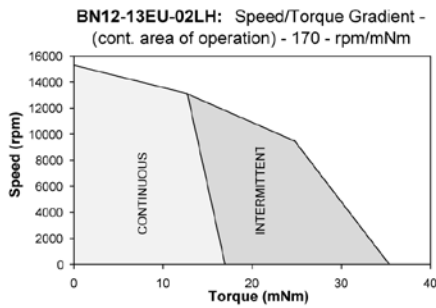
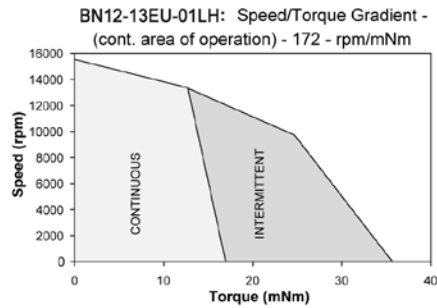

Note: Intermittent operation is based on a 20% duty cycle of one minute on, four minutes off. Please contact the factory regarding the duty cycle of your application.

BN12 IP65 Specifications

Inside Rotor
Brushless Motors

BN12 IP65 SPECIFICATIONS - Continuous Stall Torque 2.4 - 8.6 oz-in (0.0170 - 0.0607 Nm)
Peak Torque 13 - 77 oz-in (0.0918 - 0.5437 Nm)

Part Number*		BN12-13IP- <input type="checkbox"/> <input type="checkbox"/> <input checked="" type="checkbox"/> <input checked="" type="checkbox"/> <input checked="" type="checkbox"/> <input checked="" type="checkbox"/>			BN12-18IP- <input type="checkbox"/> <input type="checkbox"/> <input checked="" type="checkbox"/> <input checked="" type="checkbox"/> <input checked="" type="checkbox"/> <input checked="" type="checkbox"/>			BN12-23IP- <input type="checkbox"/> <input type="checkbox"/> <input checked="" type="checkbox"/> <input checked="" type="checkbox"/> <input checked="" type="checkbox"/> <input checked="" type="checkbox"/>			BN12-28IP- <input type="checkbox"/> <input type="checkbox"/> <input checked="" type="checkbox"/> <input checked="" type="checkbox"/> <input checked="" type="checkbox"/> <input checked="" type="checkbox"/>		
Winding Code**		01	02	03	01	02	03	01	02	03	01	02	03
L = Length	inches	1.82			2.32			2.82			3.32		
	millimeters	46.2			58.9			71.6			84.3		
Terminal Voltage	volts DC	12.0	24.0	36.0	12.0	24.0	36.0	12.0	24.0	36.0	12.0	24.0	36.0
Peak Torque	oz-in	13.0	13.0	14.0	37.0	37.0	39.0	58.0	58.0	61.0	77.0	77.0	72.0
	Nm	0.0918	0.0918	0.0989	0.2613	0.2613	0.2754	0.4096	0.4096	0.4308	0.5437	0.5437	0.5084
Continuous Stall Torque	oz-in	2.4	2.4	2.4	4.9	5.0	5.0	6.9	6.9	6.9	8.3	8.6	8.6
	Nm	0.0169	0.0169	0.0169	0.0346	0.0353	0.0353	0.0487	0.0487	0.0487	0.0586	0.0607	0.0607
Rated Speed	RPM	13027.0	12736.0	13753.0	11928.0	11448.0	12320.0	10604.0	10601.0	11489.0	11036.0	10253.0	9529.0
	rad/sec	1364	1334	1440	1249	1199	1290	1110	1110	1203	1156	1074	998
Rated Torque	oz-in	1.8	1.8	1.8	3.5	3.6	3.5	5.0	5.0	4.7	5.4	5.9	6.2
	Nm	0.0127	0.0127	0.0127	0.0247	0.0254	0.0247	0.0353	0.0353	0.0332	0.0381	0.0417	0.0438
Rated Current	Amps	2.26	1.13	0.77	3.49	1.76	1.20	4.32	2.16	1.46	4.81	2.46	1.61
Rated Power	watts	17.3	17.0	18.3	30.9	30.5	31.9	39.2	39.2	39.9	44.1	44.7	43.7
Torque Sensitivity	oz-in/amp	1.02	2.06	2.95	1.24	2.56	3.64	1.42	2.84	4.01	1.41	2.99	4.75
	Nm/amp	0.0072	0.0145	0.0208	0.0088	0.0181	0.0257	0.0100	0.0201	0.0283	0.0100	0.0211	0.0335
Back EMF	volts/KRPM	0.75	1.53	2.18	0.92	1.89	2.69	1.05	2.10	2.96	1.04	2.21	3.51
	volts/rad/sec	0.0072	0.0145	0.0208	0.0088	0.0181	0.0257	0.0100	0.0201	0.0283	0.0100	0.0211	0.0335
Terminal Resistance	ohms	0.953	3.89	7.85	0.403	1.67	3.36	0.294	1.18	2.36	0.219	0.934	2.36
Terminal Inductance	mH	0.254	1.100	2.210	0.181	0.742	1.460	0.172	0.692	1.374	0.128	0.447	1.220
Motor Constant	oz-in/sq.rt.watt	1.04	1.04	1.05	1.95	1.98	1.99	2.62	2.61	2.61	3.01	3.09	3.09
	Nm/sq.rt.watt	0.00738	0.00738	0.00744	0.01379	0.01399	0.01402	0.01849	0.01846	0.01843	0.02128	0.02185	0.02183
Rotor Inertia	oz-in-sec ² x10 ⁻³	0.040	0.040	0.040	0.080	0.080	0.080	0.120	0.120	0.120	0.16	0.16	0.16
	g-cm ²	2.82	2.82	2.82	5.65	5.65	5.65	8.47	8.47	8.47	11.3	11.3	11.3
Weight	oz	3.6	3.6	3.6	5.5	5.5	5.5	7.3	7.3	7.3	9.1	9.2	9.2
	g	102.2	102.2	102.2	156.2	156.2	156.2	207.3	207.3	207.3	258.4	261.3	261.3
# of Poles		8.0	8.0	8.0	8.0	8.0	8.0	8.0	8.0	8.0	8.0	8.0	8.0
Timing		120°	120°	120°	120°	120°	120°	120°	120°	120°	120°	120°	120°
Mech. Time Constant	ms	5.2	5.2	5.1	3.0	2.9	2.9	2.5	2.5	2.5	2.5	2.4	2.4
Electrical Time Constant	ms	0.14	0.14	0.14	0.24	0.25	0.25	0.29	0.29	0.29	0.29	0.31	0.31
Thermal Resistivity	deg. C/watt	10.7	10.3	11.2	9.5	8.9	9.3	8.3	8.3	8.3	7.7	7.3	7.4
Speed/Torque Gradient	rpm/oz-in	1245.8	1234.2	1220.6	353.3	345.2	343.2	197.2	197.9	198.8	149.3	141.3	141.6

- Notes:
- Motor mounted to a 4 x 4 x 1/4 inches aluminum plate, still air.
 - Maximum winding temperature of 155°C.
 - Typical electrical specifications at 25°C.
 - Motor Terminal Voltages are representative only; motors may be operated at voltages other than those listed in the table. For assistance please contact our applications engineer.
 - Calculated (theoretical) speed/torque gradient.
 - For MS (military style) connector, please specify connector housing and terminal.
 - Data for informational purposes only. Should not be considered a binding performance agreement. For specific applications, please contact the factory.

- *Many other custom mechanical options are available – consult factory.
**Many other winding options are available – consult factory.
- Select your options below and place their code in its corresponding block as shown on page 5.
- | | | |
|--|---|--|
| <input checked="" type="checkbox"/> TERMINATION | <input checked="" type="checkbox"/> FEEDBACK OPTIONS | <input checked="" type="checkbox"/> OTHER OPTIONS |
| L – Leads (std) | H – Hall Effect (std) | D – Drive |
| C – Connector | M – MS connector | G – Gearhead |

BN12 IP65 Typical Outline

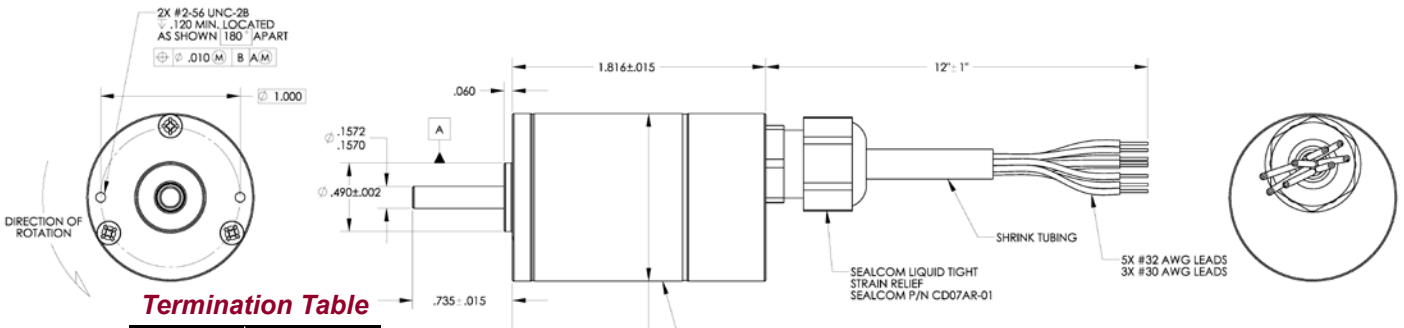

Termination Table

PIN COLOR	CONNECTION
YELLOW	V _{CC}
GRAY	GROUND
RED	A COIL
BLACK	B COIL
GREEN	C COIL
BLUE	S2 OUT
BROWN	S1 OUT
ORANGE	S3 OUT

Dimensions are in inches

BN12 IP65 Performance Curves

BN12 IP65 Performance Curves

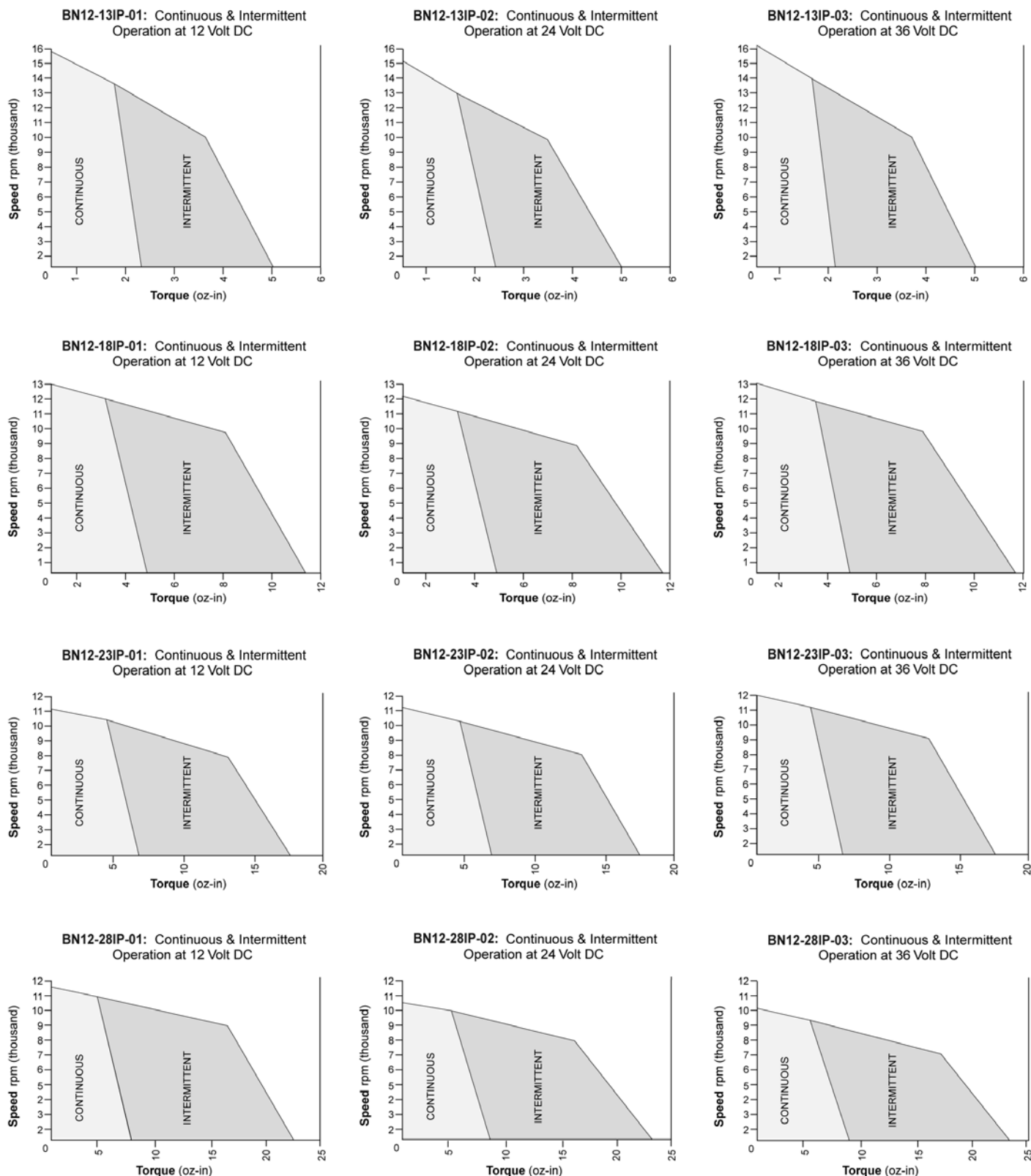

Note: Intermittent operation is based on a 20% duty cycle of one minute on, four minutes off. Please contact the factory regarding the duty cycle of your application.

BN17 Specifications

BN17 SPECIFICATIONS - Continuous Stall Torque 11.0 to 21.0 oz-in (.078 - .148 Nm) Peak Torque 21 - 66 oz-in (.148 - .466 Nm)

Part Number*		BN17-15AA- <input type="checkbox"/> <input type="checkbox"/> <input type="checkbox"/> <input type="checkbox"/> <input type="checkbox"/> <input type="checkbox"/>			BN17-20AA- <input type="checkbox"/> <input type="checkbox"/> <input type="checkbox"/> <input type="checkbox"/> <input type="checkbox"/> <input type="checkbox"/>			BN17-25AA- <input type="checkbox"/> <input type="checkbox"/> <input type="checkbox"/> <input type="checkbox"/> <input type="checkbox"/> <input type="checkbox"/>		
Winding Code**		01	02	03	01	02	03	01	02	03
L = Length	inches	1.5			2			2.5		
	millimeters	38.1			50.8			63.5		
Terminal Voltage	volts DC	12	24	36	12	24	36	12	24	36
Peak Torque	oz-in	22	21	21	45	45	45	66	65	65
	Nm	0.155	0.148	0.148	0.318	0.318	0.318	0.466	0.459	0.459
Continuous Stall Torque	oz-in	11	11	12	17	18	19	19	20	21
	Nm	0.078	0.078	0.085	0.120	0.127	0.134	0.134	0.141	0.148
No-Load Speed	RPM	12,322	16,830	16,290	10,185	10,484	11,084	9,554	9,582	9,000
Rated Speed	RPM	8037	13,498	12,945	5568	7131	7937	5535	6908	6344
	rad/sec	841	1413	1355	583	747	831	580	723	664
Rated Torque	oz-in	9.22	8.2	9.25	14.85	16.01	16.5	16.15	15.1	17.81
	Nm	0.065	0.058	0.065	0.105	0.113	0.117	0.114	0.107	0.126
Rated Current	Amps	8.38	4.71	3.33	10.6	5.31	3.78	11.29	5.57	3.62
Rated Power	watts	55	82	89	61	84	97	66	77	84
Torque Sensitivity	oz-in/amp	1.29	1.83	2.9	1.54	3.05	4.34	1.68	3.32	5.33
	Nm/amp	0.009	0.013	0.020	0.011	0.022	0.031	0.012	0.023	0.038
Back EMF	volts/KRPM	0.95	1.35	2.14	1.14	2.26	3.21	1.24	2.45	3.94
	volts/rad/sec	0.009	0.013	0.020	0.011	0.022	0.031	0.012	0.023	0.038
Terminal Resistance	ohms	0.228	0.531	1.154	0.206	0.672	1.277	0.194	0.594	1.414
Terminal Inductance	mH	0.201	0.437	1.100	0.178	0.437	1.466	0.168	0.648	1.661
Motor Constant	oz-in/sq.rt.watt	2.70	2.51	2.70	3.39	3.72	3.84	3.81	4.31	4.48
	Nm/sq.rt.watt	0.019	0.018	0.019	0.024	0.026	0.027	0.027	0.030	0.032
Rotor Inertia	oz-in-sec ² x10 ⁻³	0.26	0.26	0.26	0.4	0.4	0.4	0.48	0.40	0.48
	g-cm ²	18.41	18.41	18.41	28.33	28.33	28.33	33.99	33.99	33.99
Weight	oz	7	7	7	10.4	10.4	10.3	13.7	13.6	13.7
	g	198	198	198	294	294	291	388	385	388
# of Poles		4	4	4	4	4	4	4	4	4
Timing		120°	120°	120°	120°	120°	120°	120°	120°	120°
Mech. Time Constant	ms	21.3	16	16	18.1	14.5	14.5	19.1	18.6	13.1
Electrical Time Constant	ms	0.20	0.18	0.67	0.18	0.42	0.61	0.40	0.98	0.90
Thermal Resistivity	deg. C/watt	2.95	3.95	3.93	1.86	2.86	3.14	1.77	2.18	2.64
Speed/Torque Gradient	rpm/oz-in	465	406	362	311	210	191	249	177	149

- Notes:
- Motor mounted to a 4 x 4 x 1/4 inches aluminum plate, still air.
 - Maximum winding temperature of 155°C.
 - Typical electrical specifications at 25°C.
 - Motor Terminal Voltages are representative only; motors may be operated at voltages other than those listed in the table. For assistance please contact our applications engineer.
 - For MS (military style) connector, please specify connector housing and terminal.
 - Data for informational purposes only. Should not be considered a binding performance agreement. For specific applications, please contact the factory.

*Many other custom mechanical options are available – consult factory.
**Many other winding options are available – consult factory.

Select your options below and place their code in its corresponding block as shown on page 5.

- | | | |
|---|--|---|
| <input type="checkbox"/> TERMINATION | <input type="checkbox"/> FEEDBACK OPTIONS | <input type="checkbox"/> OTHER OPTIONS |
| L – Leads (std) | H – Hall Effect (std) | E – Encoder |
| C – Connector | R – Resolver | G – Gearhead |
| M – MS connector | S – Sensorless | |

BN17 Typical Outline

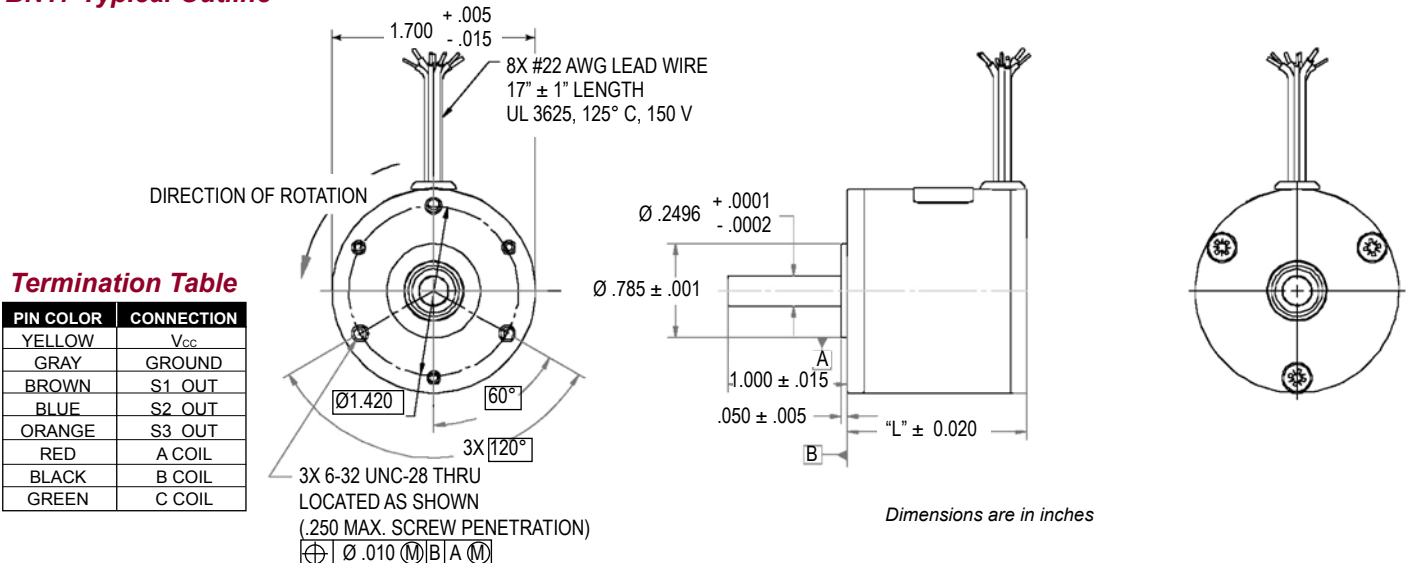

BN17 Performance Curves

BN17 Performance Curves

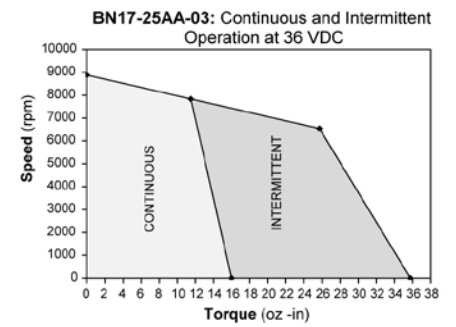
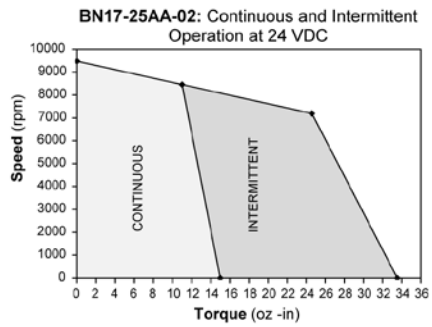
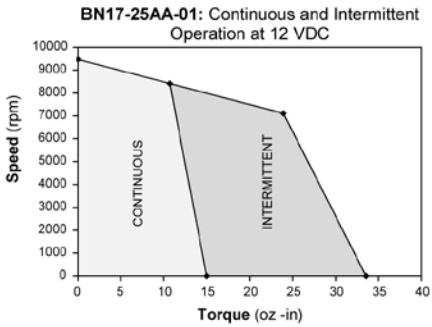
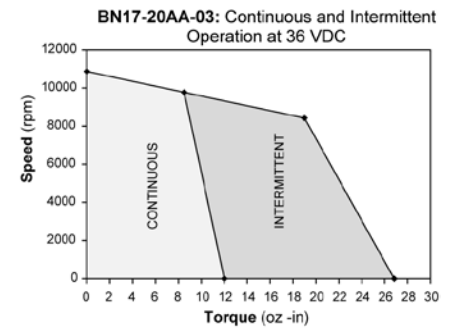
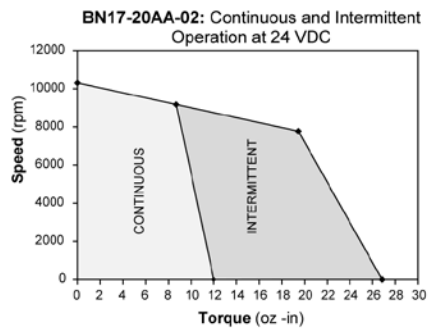
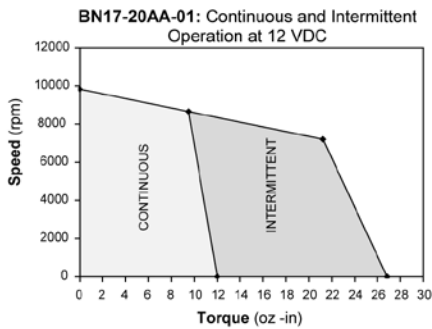
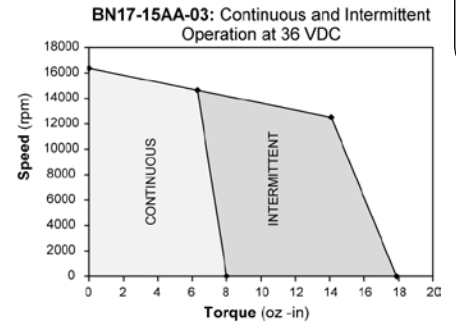
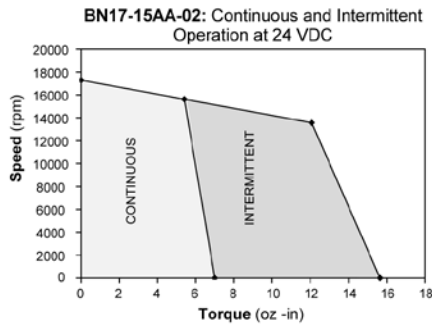
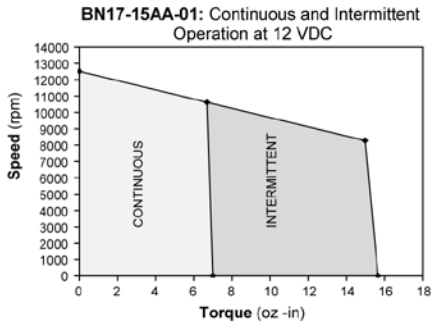

Note: Intermittent operation is based on a 20% duty cycle of one minute on, four minutes off.
Please contact the factory regarding the duty cycle of your application.

BN17 IP65 Specifications

Inside Rotor
Brushless Motors

BN17 IP65 SPECIFICATIONS - Continuous Stall Torque 11.0 to 21.0 oz-in (.078 - .148 Nm) Peak Torque 21 - 66 oz-in (.148 - .466 Nm)

Part Number*		BN17-15IP- <input type="checkbox"/> <input type="checkbox"/> <input type="checkbox"/> <input type="checkbox"/> <input type="checkbox"/> <input type="checkbox"/>			BN17-20IP- <input type="checkbox"/> <input type="checkbox"/> <input type="checkbox"/> <input type="checkbox"/> <input type="checkbox"/> <input type="checkbox"/>			BN17-25IP- <input type="checkbox"/> <input type="checkbox"/> <input type="checkbox"/> <input type="checkbox"/> <input type="checkbox"/> <input type="checkbox"/>		
Winding Code**		01	02	03	01	02	03	01	02	03
L = Length	inches	2.06			2.56			3.06		
	millimeters	52.32			65.02			77.72		
Terminal Voltage	volts DC	12	24	36	12	24	36	12	24	36
Peak Torque	oz-in	22	21	21	45	45	45	66	65	65
	Nm	0.155	0.148	0.148	0.318	0.318	0.318	0.466	0.459	0.459
Continuous Stall Torque	oz-in	11	11	12	17	18	19	19	20	21
	Nm	0.078	0.078	0.085	0.120	0.127	0.134	0.134	0.141	0.148
No-Load Speed	RPM	12,322	16,830	16,290	10,185	10,484	11,084	9,554	9,582	9,000
Rated Speed	RPM	8037	13,498	12,945	5568	7131	7937	5535	6908	6344
	rad/sec	841	1413	1355	583	747	831	580	723	664
Rated Torque	oz-in	9.22	8.2	9.25	14.85	16.01	16.5	16.15	15.1	17.81
	Nm	0.065	0.058	0.065	0.105	0.113	0.117	0.114	0.107	0.126
Rated Current	Amps	8.38	4.71	3.33	10.6	5.31	3.78	11.29	5.57	3.62
Rated Power	watts	55	82	89	61	84	97	66	77	84
Torque Sensitivity	oz-in/amp	1.29	1.83	2.9	1.54	3.05	4.34	1.68	3.32	5.33
	Nm/amp	0.009	0.013	0.020	0.011	0.022	0.031	0.012	0.023	0.038
Back EMF	volts/KRPM	0.95	1.35	2.14	1.14	2.26	3.21	1.24	2.45	3.94
	volts/rad/sec	0.009	0.013	0.020	0.011	0.022	0.031	0.012	0.023	0.038
Terminal Resistance	ohms	0.228	0.531	1.150	0.206	0.672	1.277	0.194	0.594	1.414
Terminal Inductance	mH	0.201	0.437	1.100	0.178	0.437	1.466	0.168	0.648	1.661
Motor Constant	oz-in/sq.rt.watt	2.70	2.51	2.70	3.39	3.72	3.84	3.81	4.31	4.48
	Nm/sq.rt.watt	0.019	0.018	0.019	0.024	0.026	0.027	0.027	0.030	0.032
Rotor Inertia	oz-in-sec ² x10 ⁻³	0.26	0.26	0.26	0.4	0.4	0.4	0.48	0.48	0.48
	g-cm ²	18.41	18.41	18.41	28.33	28.33	28.33	33.99	33.99	33.99
Weight	oz	7	7	7	10.4	10.4	10.3	13.7	13.6	13.7
	g	198	198	198	294	294	291	388	385	388
# of Poles		4	4	4	4	4	4	4	4	4
Timing		120°	120°	120°	120°	120°	120°	120°	120°	120°
Mech. Time Constant	ms	21.3	16	16	18.1	14.5	14.5	19.1	18.6	13.1
Electrical Time Constant	ms	0.20	0.18	0.67	0.18	0.42	0.61	0.40	0.98	0.90
Thermal Resistivity	deg. C/watt	2.95	3.95	3.93	1.86	2.86	3.14	1.77	2.18	2.64
Speed/Torque Gradient	rpm/oz-in	465	406	362	311	210	191	249	177	149

Notes:

- Motor mounted to a 4 x 4 x 1/4 inches aluminum plate, still air.
- Maximum winding temperature of 155°C.
- Typical electrical specifications at 25°C.
- Motor Terminal Voltages are representative only; motors may be operated at voltages other than those listed in the table. For assistance please contact our applications engineer.
- For MS (military style) connector, please specify connector housing and terminal.
- Data for informational purposes only. Should not be considered a binding performance agreement. For specific applications, please contact the factory.

*Many other custom mechanical options are available – consult factory.

**Many other winding options are available – consult factory.

Select your options below and place their code in its corresponding block as shown on page 5.

- | | | |
|--|---|--|
| <input checked="" type="checkbox"/> TERMINATION | <input checked="" type="checkbox"/> FEEDBACK OPTIONS | <input checked="" type="checkbox"/> OTHER OPTIONS |
| L – Leads (std) | H – Hall Effect (std) | D – Drive |
| C – Connector | | G – Gearhead |
| M – MS connector | | |

BN17 IP65 Housed / Frameless

Inside Rotor
Brushless Motors

BN17 IP65 Typical Outline - Housed

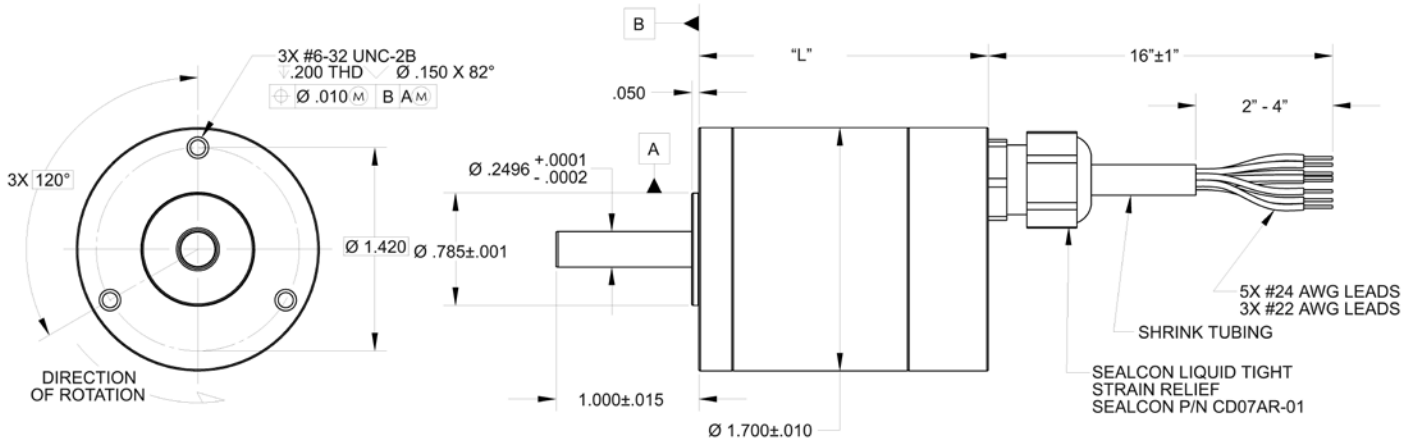

Dimensions are in inches

BN17 IP65 Typical Outline - Frameless

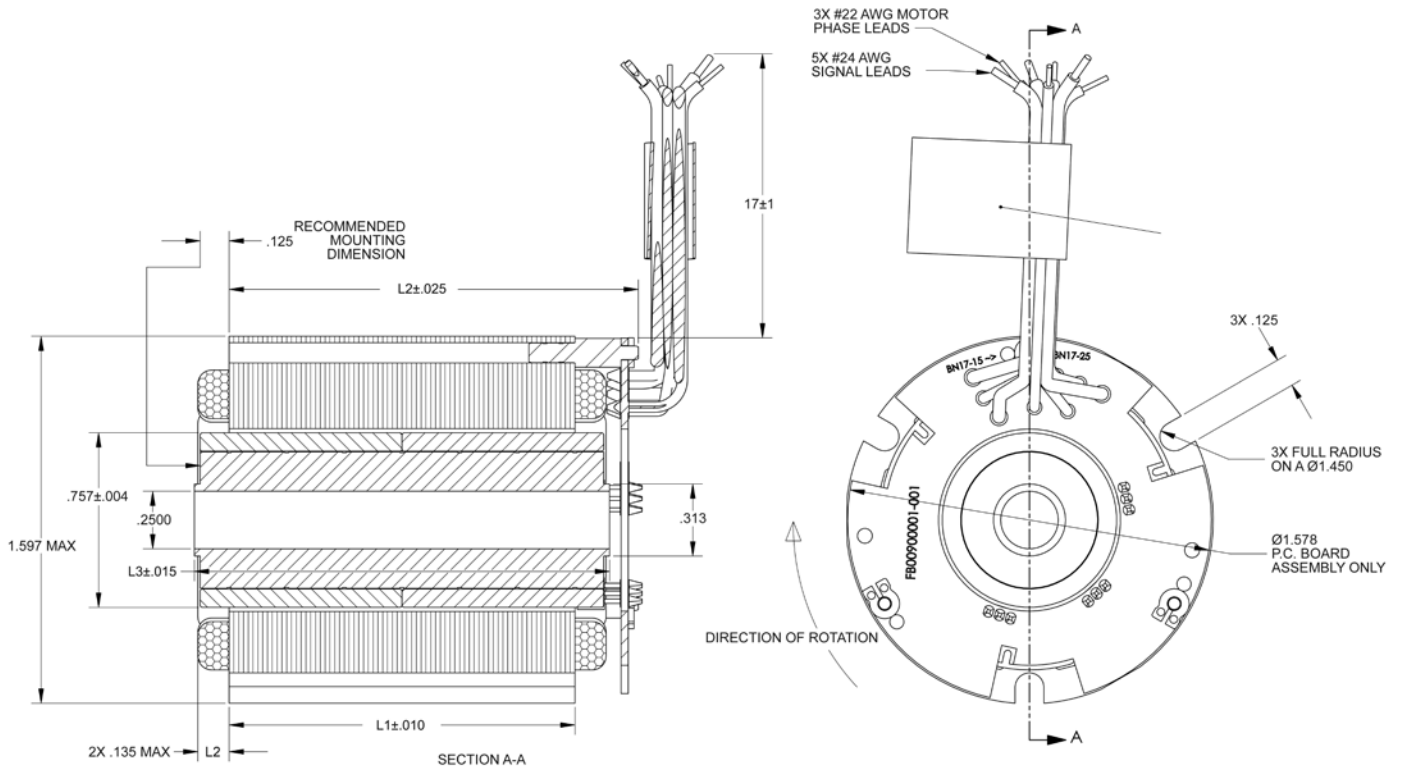

Dimensions are in inches

Termination Table

PIN COLOR	CONNECTION
YELLOW	V _{CC}
GRAY	GROUND
BROWN	S1 OUT
BLUE	S2 OUT
ORANGE	S3 OUT
RED	A COIL
BLACK	B COIL
GREEN	C COIL

PART NUMBER	L1	L2	L3
BN17-15ZA-XXLH	0.500	0.780	0.800
BN17-20ZA-XXLH	1.000	1.280	1.300
BN17-25ZA-XXLH	1.500	1.780	1.800

Note: For electrical performance see page 14.

BN17 IP65 Performance Curves

Inside Rotor
Brushless Motors

BN17 IP65 Performance Curves

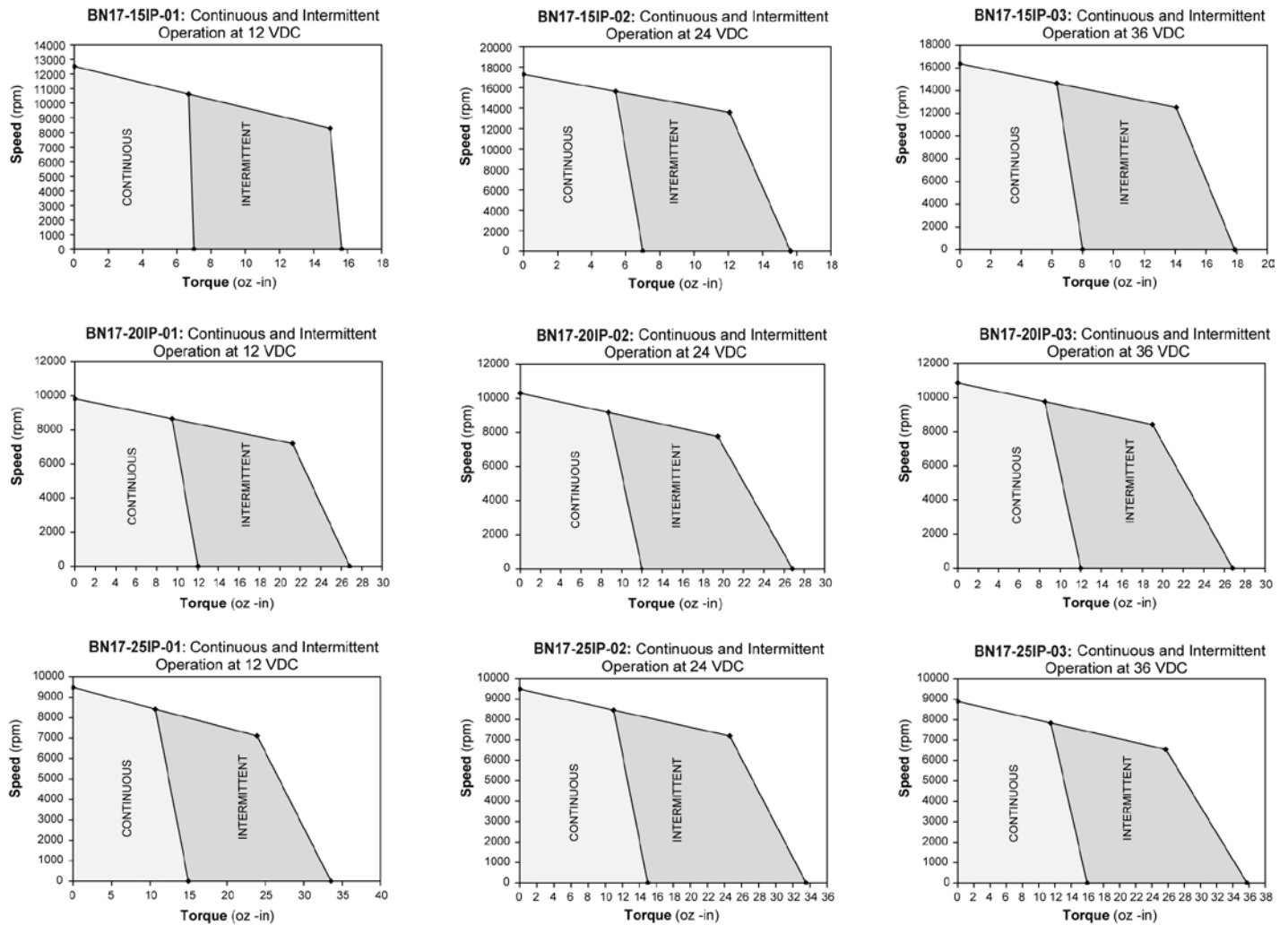

Note: Intermittent operation is based on a 20% duty cycle of one minute on, four minutes off. Please contact the factory regarding the duty cycle of your application.

BN23 Specifications

Inside Rotor
Brushless Motors

BN23 SPECIFICATIONS - *Continuous Stall Torque 14.6 - 54.3 oz-in (0.103 - 0.384 Nm) Peak Torque 35 - 186 oz-in (0.2472 - 1.3134 Nm)*

Part Number*		BN23-13MG- <input type="checkbox"/> <input type="checkbox"/> <input type="checkbox"/> <input type="checkbox"/> <input type="checkbox"/>			BN23-18MG- <input type="checkbox"/> <input type="checkbox"/> <input type="checkbox"/> <input type="checkbox"/> <input type="checkbox"/>			BN23-23MG- <input type="checkbox"/> <input type="checkbox"/> <input type="checkbox"/> <input type="checkbox"/> <input type="checkbox"/>			BN23-28MG- <input type="checkbox"/> <input type="checkbox"/> <input type="checkbox"/> <input type="checkbox"/> <input type="checkbox"/>		
Winding Code**		01	02	03	01	02	03	01	02	03	01	02	03
L = Length	inches	1.40			1.90			2.40			2.90		
	millimeters	35.6			48.3			60.9			73.7		
Terminal Voltage	volts DC	24	36	48	24	36	48	24	36	48	24	36	48
Peak Torque	oz-in	35	35	35	88	88	88	143	143	143	186	186	186
	Nm	0.2472	0.2472	0.2472	0.6214	0.6214	0.6214	1.0098	1.0098	1.0098	1.3134	1.3134	1.3134
Continuous Stall Torque	oz-in	14.6	17.7	14.2	30.7	31.4	35.2	42.8	44.7	42.9	50.4	54.3	53.2
	Nm	0.103	0.125	0.100	0.217	0.221	0.248	0.303	0.315	0.303	0.356	0.384	0.376
No-Load Speed		12,200	12,500	12,300	9,100	9,700	10,200	8,100	8,800	8,200	7,300	7,500	8,100
Rated Speed	RPM	8650	9060	9190	6460	7000	7130	6060	6700	6250	5340	5590	6140
	rad/sec	906	949	962	676	733	747	635	702	655	559	585	643
Rated Torque	oz-in	14.2	16.1	12.1	29.7	29.8	32.9	40.3	42.3	41.8	49.1	51.9	48.8
	Nm	0.100	0.114	0.085	0.210	0.210	0.232	0.285	0.299	0.295	0.347	0.366	0.345
Rated Current	Amps	5.80	4.30	2.38	7.75	5.43	4.88	9.47	7.44	5.00	10.45	7.66	5.85
Rated Power	watts	91	108	82	142	154	174	181	210	193	194	215	222
Torque Sensitivity	oz-in/amp	2.55	3.78	5.18	3.40	4.90	6.25	3.85	5.35	7.79	4.26	6.30	7.80
	Nm/amp	0.018	0.027	0.037	0.024	0.035	0.044	0.027	0.038	0.055	0.030	0.044	0.055
Back EMF	volts/KRPM	1.89	2.80	3.83	2.51	3.62	4.62	2.85	3.96	5.76	3.15	4.66	5.77
	volts/rad/sec	0.018	0.027	0.037	0.024	0.035	0.044	0.027	0.038	0.055	0.030	0.044	0.055
Terminal Resistance	ohms	0.465	0.939	1.890	0.246	0.507	0.800	0.178	0.347	0.715	0.181	0.366	0.576
Terminal Inductance	mH	0.350	0.758	1.53	0.275	0.580	0.930	0.220	0.420	0.900	0.230	0.490	0.770
Motor Constant	oz-in/sq.rt.watt	3.74	3.90	3.77	6.86	6.88	6.99	9.13	9.08	9.21	10.01	10.41	10.28
	Nm/sq.rt.watt	0.026	0.028	0.027	0.048	0.049	0.049	0.064	0.064	0.065	0.071	0.074	0.073
Rotor Inertia	oz-in-sec ² x10 ⁻³	0.51	0.51	0.51	0.99	0.99	0.99	1.5	1.5	1.5	1.9	1.9	1.9
	g-cm ²	36	36	36	70	70	70	106	106	106	134	134	134
Weight	oz	8.3	8.4	8.3	13.6	13.7	13.8	19.1	19.1	19.1	24.4	24.7	24.5
	g	234.0	238.0	234.0	386.0	389.0	391.0	542.0	542.0	542.0	693.0	699.0	694.0
# of Poles		8.0	8.0	8.0	8.0	8.0	8.0	8.0	8.0	8.0	8.0	8.0	8.0
Timing		120°	120°	120°	120°	120°	120°	120°	120°	120°	120°	120°	120°
Mech. Time Constant	ms	5.20	4.7	5.1	3.0	3.0	2.9	2.5	2.6	2.5	2.7	2.5	2.5
Electrical Time Constant	ms	0.75	0.81	0.81	1.12	1.14	1.16	1.24	1.21	1.26	1.27	1.34	1.34
Thermal Resistivity	deg. C/watt	2.28	2.34	3.44	2.49	2.67	1.81	2.36	1.89	2.35	1.93	1.80	1.86
Speed/Torque Gradient	rpm/oz-in	250.0	213.7	257.0	88.9	90.6	93.3	50.6	49.6	46.7	39.9	36.8	40.2

Notes:

- Motor mounted to a 6 x 6 x 1/4 inches aluminum plate, still air.
- Maximum winding temperature of 155°C.
- Typical electrical specifications at 25°C.
- Data shown for 8 pole motors. Please consult factory for 4 pole specifications.
- Motor Terminal Voltages are representative only; motors may be operated at voltages other than those listed in the table. For assistance please contact our applications engineer.
- For MS (military style) connector, please specify connector housing and terminal.
- Data for informational purposes only. Should not be considered a binding performance agreement. For specific applications, please contact the factory.

*Many other custom mechanical options are available – consult factory.

**Many other winding options are available – consult factory.

Select your options below and place their code in its corresponding block as shown on page 5.

- | | | |
|--|---|--|
| <input checked="" type="checkbox"/> TERMINATION | <input checked="" type="checkbox"/> FEEDBACK OPTIONS | <input checked="" type="checkbox"/> OTHER OPTIONS |
| L – Leads (std) | H – Hall Effect (std) | D – Drive |
| C – Connector | R – Resolver | E – Encoder |
| M – MS connector | S – Sensorless | G – Gearhead |

BN23 Housed / Frameless

Inside Rotor
Brushless Motors

BN23 Typical Outline - Housed

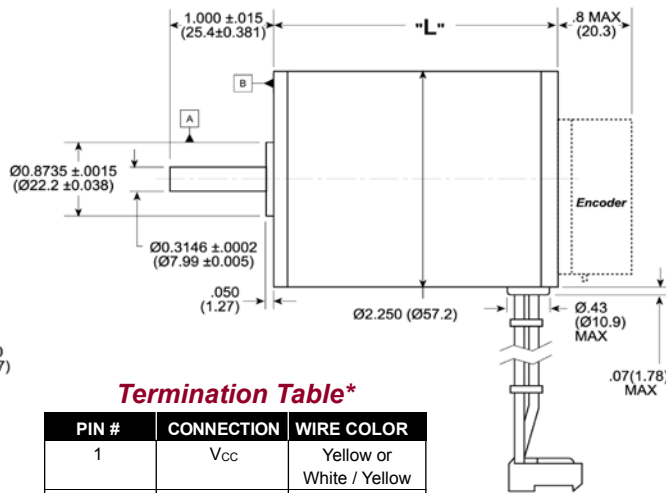
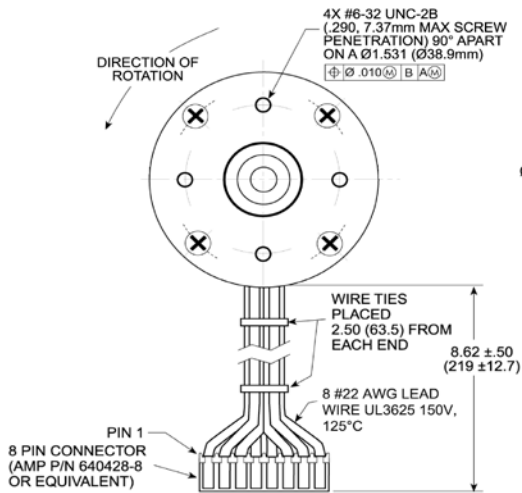

Termination Table*

PIN #	CONNECTION	WIRE COLOR
1	V _{CC}	Yellow or White / Yellow
2	GROUND	White / Gray
3	A COIL	White / Violet
4	B COIL	White / Black
5	C COIL	Green
6	S2 OUT	White / Blue
7	S1 OUT	White / Brown
8	S3 OUT	White

Dimensions are in inches (millimeters)

*We reserve the right to use solid color wires or white wires with color trace.

BN23 Typical Outline - Frameless

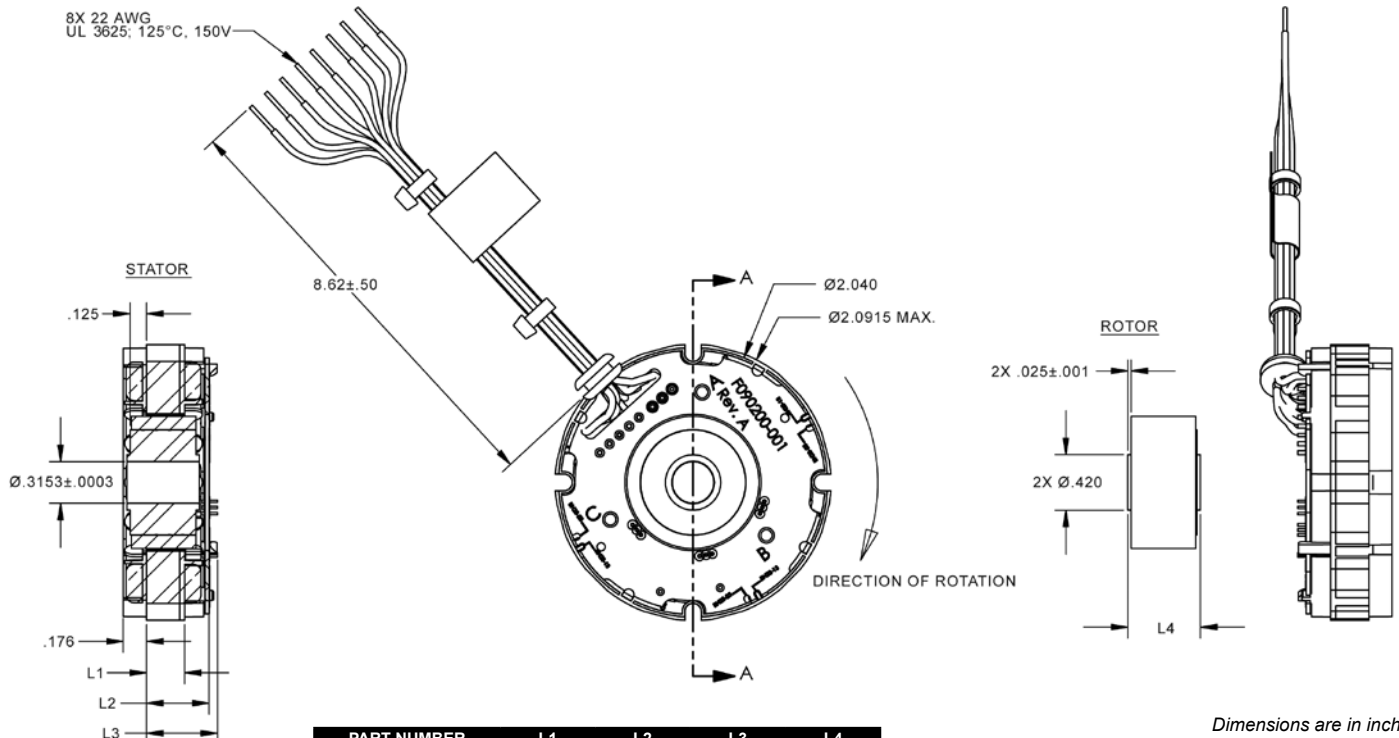

PART NUMBER	L1	L2	L3	L4
BN23-13ZMG-XXLH	0.288	0.474	0.550	0.550
BN23-18ZMG-XXLH	0.788	0.974	1.050	1.050
BN23-23ZMG-XXLH	1.288	1.470	1.550	1.550
BN23-28ZMG-XXLH	1.788	1.970	2.050	2.050

Note: For electrical performance see page 17.

Dimensions are in inches

BN23 Performance Curves

BN23 Performance Curves

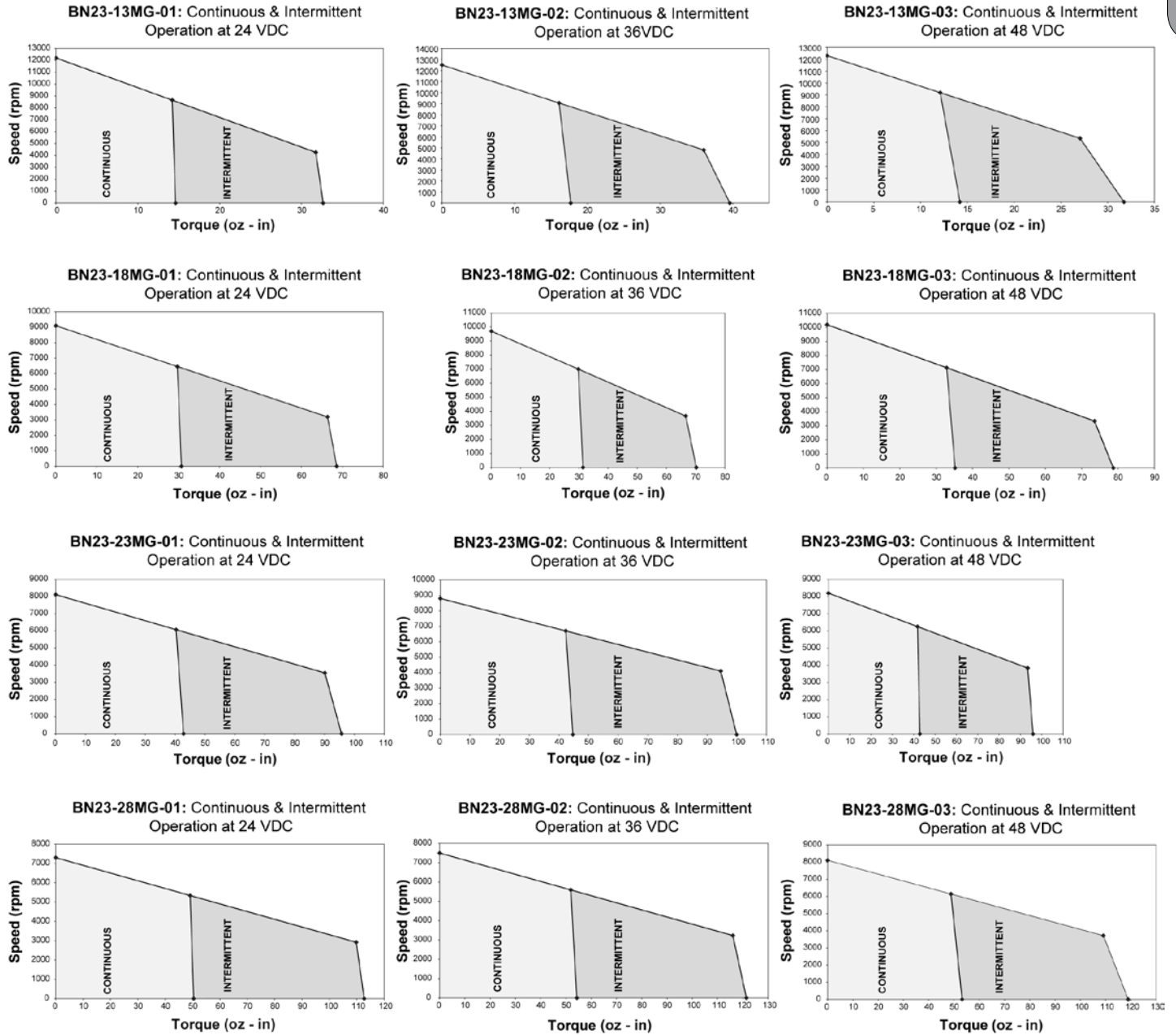

Note: Intermittent operation is based on a 20% duty cycle of one minute on, four minutes off. Please contact the factory regarding the duty cycle of your application.

BN23 EU Specifications

BN23 EU SPECIFICATIONS -

Continuous Stall Torque 14.6 - 54.3 oz-in (0.103 - 0.384 Nm)
Peak Torque 35 - 186 oz-in (0.2472 - 1.3134 Nm)

Part Number*		BN23-13EU- <input type="checkbox"/> <input type="checkbox"/> <input type="checkbox"/> <input type="checkbox"/>			BN23-18EU- <input type="checkbox"/> <input type="checkbox"/> <input type="checkbox"/> <input type="checkbox"/>			BN23-23EU- <input type="checkbox"/> <input type="checkbox"/> <input type="checkbox"/> <input type="checkbox"/>			BN23-28EU- <input type="checkbox"/> <input type="checkbox"/> <input type="checkbox"/> <input type="checkbox"/>		
		01	02	03	01	02	03	01	02	03	01	02	03
Winding Code**		01	02	03	01	02	03	01	02	03	01	02	03
	L = Length	inches 1.40			1.90			2.40			2.90		
		millimeters 35.6			48.3			60.9			73.7		
Terminal Voltage	volts DC	24	36	48	24	36	48	24	36	48	24	36	48
Peak Torque	oz-in	35	35	35	88	88	88	143	143	143	186	186	186
	Nm	0.2472	0.2472	0.2472	0.6214	0.6214	0.6214	1.0098	1.0098	1.0098	1.3134	1.3134	1.3134
Continuous Stall Torque	oz-in	14.6	17.7	14.2	30.7	31.4	35.2	42.8	44.7	42.9	50.4	54.3	53.2
	Nm	0.103	0.125	0.100	0.217	0.221	0.248	0.303	0.315	0.303	0.356	0.384	0.376
No-Load Speed		12,200	12,500	12,300	9,100	9,700	10,200	8,100	8,800	8,200	7,300	7,500	8,100
Rated Speed	RPM	8650	9060	9190	6460	7000	7130	6060	6700	6250	5340	5590	6140
	rad/sec	906	949	962	676	733	747	635	702	655	559	585	643
Rated Torque	oz-in	14.2	16.1	12.1	29.7	29.8	32.9	40.3	42.3	41.8	49.1	51.9	48.8
	Nm	0.100	0.114	0.085	0.210	0.210	0.232	0.285	0.299	0.295	0.347	0.366	0.345
Rated Current	Amps	5.80	4.30	2.38	7.75	5.43	4.88	9.47	7.44	5.00	10.45	7.66	5.85
Rated Power	watts	91	108	82	142	154	174	181	210	193	194	215	222
Torque Sensitivity	oz-in/amp	2.55	3.78	5.18	3.40	4.90	6.25	3.85	5.35	7.79	4.26	6.30	7.80
	Nm/amp	0.018	0.027	0.037	0.024	0.035	0.044	0.027	0.038	0.055	0.030	0.044	0.055
Back EMF	volts/KRPM	1.89	2.80	3.83	2.51	3.62	4.62	2.85	3.96	5.76	3.15	4.66	5.77
	volts/rad/sec	0.018	0.027	0.037	0.024	0.035	0.044	0.027	0.038	0.055	0.030	0.044	0.055
Terminal Resistance	ohms	0.465	0.939	1.890	0.246	0.507	0.800	0.178	0.347	0.715	0.181	0.366	0.576
Terminal Inductance	mH	0.350	0.758	1.53	0.275	0.580	0.930	0.220	0.420	0.900	0.230	0.490	0.770
Motor Constant	oz-in/sq.rt.watt	3.74	3.90	3.77	6.86	6.88	6.99	9.13	9.08	9.21	10.01	10.41	10.28
	Nm/sq.rt.watt	0.026	0.028	0.027	0.048	0.049	0.049	0.064	0.064	0.065	0.071	0.074	0.073
Rotor Inertia	oz-in-sec ² x10 ⁻³	0.51	0.51	0.51	0.99	0.99	0.99	1.5	1.5	1.5	1.9	1.9	1.9
	g-cm ²	36	36	36	70	70	70	106	106	106	134	134	134
Weight	oz	8.3	8.4	8.3	13.6	13.7	13.8	19.1	19.1	19.1	24.4	24.7	24.5
	g	234.0	238.0	234.0	386.0	389.0	391.0	542.0	542.0	542.0	693.0	699.0	694.0
# of Poles		8.0	8.0	8.0	8.0	8.0	8.0	8.0	8.0	8.0	8.0	8.0	8.0
Timing		120°	120°	120°	120°	120°	120°	120°	120°	120°	120°	120°	120°
Mech. Time Constant	ms	5.20	4.7	5.1	3.0	3.0	2.9	2.5	2.6	2.5	2.7	2.5	2.5
Electrical Time Constant	ms	0.75	0.81	0.81	1.12	1.14	1.16	1.24	1.21	1.26	1.27	1.34	1.34
Thermal Resistivity	deg. C/watt	2.28	2.34	3.44	2.49	2.67	1.81	2.36	1.89	2.35	1.93	1.80	1.86
Speed/Torque Gradient	rpm/oz-in	250.0	213.7	257.0	88.9	90.6	93.3	50.6	49.6	46.7	39.9	36.8	40.2

Notes:

- Motor mounted to a 6" x 6" x 1/4" aluminum plate, still air.
- Maximum winding temperature of 155°C.
- Typical electrical specifications at 25°C.
- Data shown for 8 pole motors. Please consult factory for 4 pole specifications.
- Motor Terminal Voltages are representative only; motors may be operated at voltages other than those listed in the table. For assistance please contact our applications engineer.
- For MS (military style) connector, please specify connector housing and terminal.
- Data for informational purposes only. Should not be considered a binding performance agreement. For specific applications, please contact the factory.

*Many other custom mechanical options are available – consult factory.

**Many other winding options are available – consult factory.

Select your options below and place their code in its corresponding block as shown on page 5.

- | | | |
|---|--|---|
| <input type="checkbox"/> TERMINATION | <input type="checkbox"/> FEEDBACK OPTIONS | <input type="checkbox"/> OTHER OPTIONS |
| L – Leads (std) | H – Hall Effect (std) | D – Drive |
| C – Connector | R – Resolver | E – Encoder |
| M – MS connector | S – Sensorless | G – Gearhead |

BN23 EU Typical Outline

Termination Table*

COLOR	CONNECTION
VIOLET	A COIL
GREEN	C COIL
BLACK	B COIL
GRAY	HALL GND
YELLOW	HALL V _{CC}
WHITE	HALL S3
BLUE	HALL S2
BROWN	HALL S1

*We reserve the right to use solid color wires or white wires with color trace.

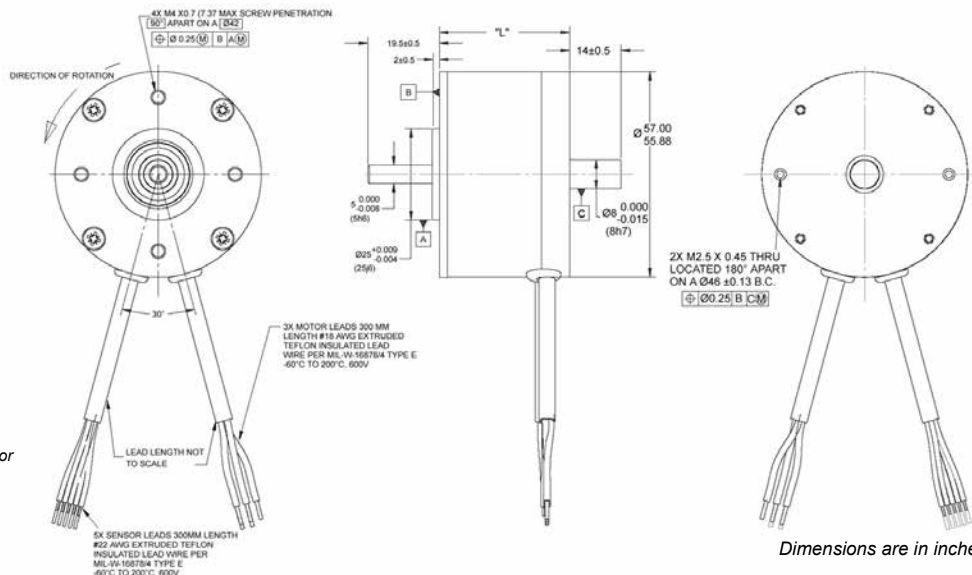

Dimensions are in inches (millimeters)

BN23 EU Performance Curves

BN23 EU Performance Curves

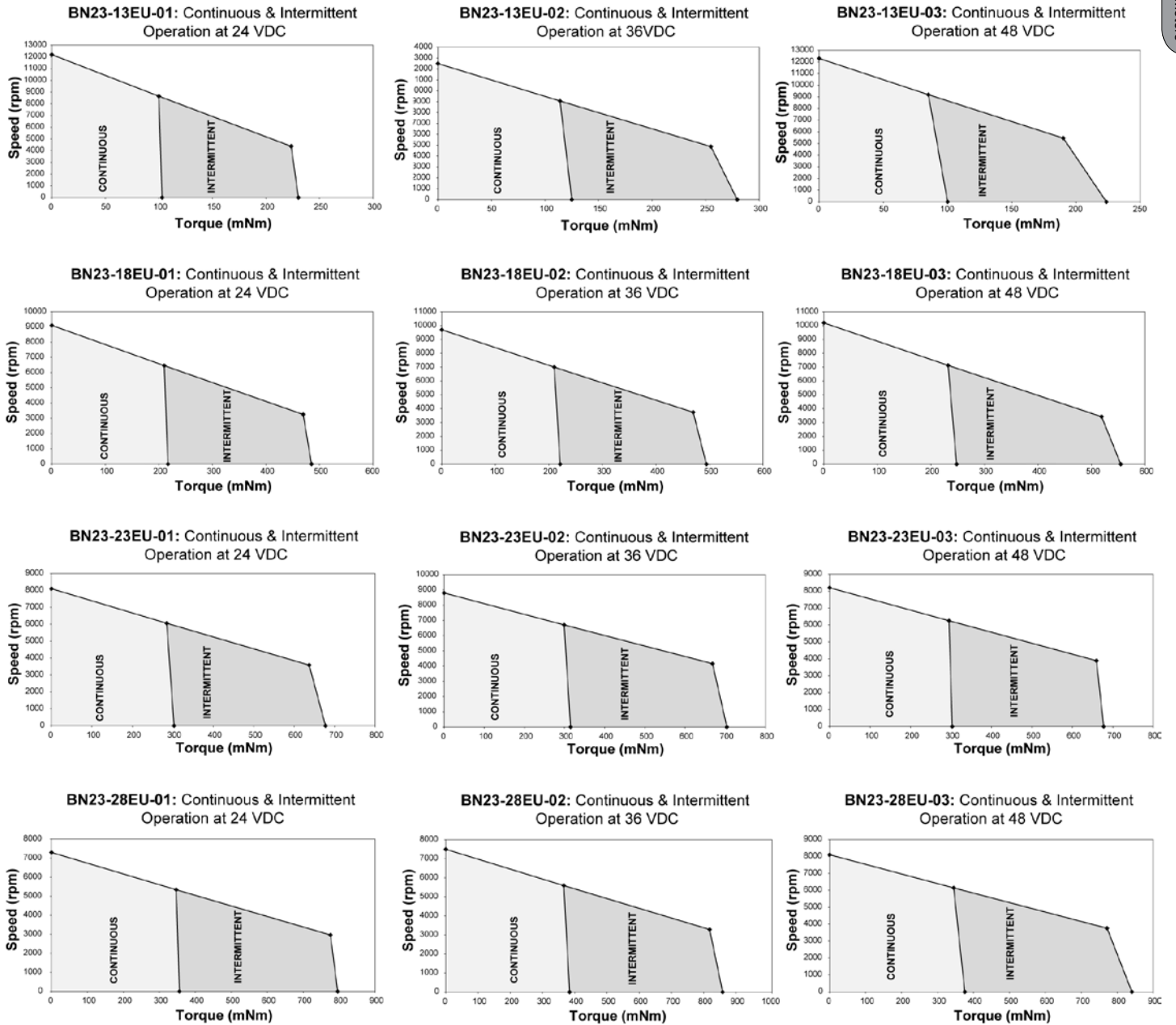

S/T Gradient = 35.4 rpm/mNm

Note: Intermittent operation is based on a 20% duty cycle of one minute on, four minutes off. Please contact the factory regarding the duty cycle of your application.

BN23 IP65 Specifications

BN23 IP65 SPECIFICATIONS - Continuous Stall Torque 12.6 - 41 oz-in (0.0890 - 0.290 Nm)
Peak Torque 35 - 186 oz-in (0.248 - 1.32 Nm)

Part Number*		BN23-13IP- <input type="checkbox"/> <input type="checkbox"/> <input type="checkbox"/> <input type="checkbox"/>			BN23-18IP- <input type="checkbox"/> <input type="checkbox"/> <input type="checkbox"/> <input type="checkbox"/>			BN23-23IP- <input type="checkbox"/> <input type="checkbox"/> <input type="checkbox"/> <input type="checkbox"/>			BN23-28IP- <input type="checkbox"/> <input type="checkbox"/> <input type="checkbox"/> <input type="checkbox"/>		
Winding Code**		01	02	03	01	02	03	01	02	03	01	02	03
L = Length	inches	2.43			2.93			3.43			3.93		
	millimeters	61.72			74.42			87.12			99.82		
Terminal Voltage	volts DC	24	36	48	24	36	48	24	36	48	24	36	48
Peak Torque	oz-in	35	35	35	88	88	88	143	143	143	186	186	186
	Nm	0.2472	0.2472	0.2472	0.6214	0.6214	0.6214	1.0098	1.0098	1.0098	1.3134	1.3134	1.3134
Continuous Stall Torque	oz-in	14.6	17.7	14.2	30.7	31.4	35.2	42.8	44.7	42.9	50.4	54.3	53.2
	Nm	0.103	0.125	0.100	0.217	0.221	0.248	0.303	0.315	0.303	0.356	0.384	0.376
No-Load Speed		12,200	12,500	12,300	9,100	9,700	10,200	8,100	8,800	8,200	7,300	7,500	8,100
Rated Speed	RPM	8650	9060	9190	6460	7000	7130	6060	6700	6250	5340	5590	6140
	rad/sec	906	949	962	676	733	747	635	702	655	559	585	643
Rated Torque	oz-in	14.2	16.1	12.1	29.7	29.8	32.9	40.3	42.3	41.8	49.1	51.9	48.8
	Nm	0.100	0.114	0.085	0.210	0.210	0.232	0.285	0.299	0.295	0.347	0.366	0.345
Rated Current	Amps	5.80	4.30	2.38	7.75	5.43	4.88	9.47	7.44	5.00	10.45	7.66	5.85
Rated Power	watts	91	108	82	142	154	174	181	210	193	194	215	222
Torque Sensitivity	oz-in/amp	2.55	3.78	5.18	3.40	4.90	6.25	3.85	5.35	7.79	4.26	6.30	7.80
	Nm/amp	0.018	0.027	0.037	0.024	0.035	0.044	0.027	0.038	0.055	0.030	0.044	0.055
Back EMF	volts/KRPM	1.89	2.80	3.83	2.51	3.62	4.62	2.85	3.96	5.76	3.15	4.66	5.77
	volts/rad/sec	0.018	0.027	0.037	0.024	0.035	0.044	0.027	0.038	0.055	0.030	0.044	0.055
Terminal Resistance	ohms	0.465	0.939	1.890	0.246	0.507	0.800	0.178	0.347	0.715	0.181	0.366	0.576
Terminal Inductance	mH	0.350	0.758	1.53	0.275	0.580	0.930	0.220	0.420	0.900	0.230	0.490	0.770
Motor Constant	oz-in/sq.rt.watt	3.74	3.90	3.77	6.86	6.88	6.99	9.13	9.08	9.21	10.01	10.41	10.28
	Nm/sq.rt.watt	0.026	0.028	0.027	0.048	0.049	0.049	0.064	0.064	0.065	0.071	0.074	0.073
Rotor Inertia	oz-in-sec ² x10 ⁻³	0.51	0.51	0.51	0.99	0.99	0.99	1.5	1.5	1.5	1.9	1.9	1.9
	g-cm ²	36	36	36	70	70	70	106	106	106	134	134	134
Weight	oz	8.3	8.4	8.3	13.6	13.7	13.8	19.1	19.1	19.1	24.4	24.7	24.5
	g	234.0	238.0	234.0	386.0	389.0	391.0	542.0	542.0	542.0	693.0	699.0	694.0
# of Poles		8.0	8.0	8.0	8.0	8.0	8.0	8.0	8.0	8.0	8.0	8.0	8.0
Timing		120°	120°	120°	120°	120°	120°	120°	120°	120°	120°	120°	120°
Mech. Time Constant	ms	5.20	4.7	5.1	3.0	3.0	2.9	2.5	2.6	2.5	2.7	2.5	2.5
Electrical Time Constant	ms	0.75	0.81	0.81	1.12	1.14	1.16	1.24	1.21	1.26	1.27	1.34	1.34
Thermal Resistivity	deg. C/watt	2.28	2.34	3.44	2.49	2.67	1.81	2.36	1.89	2.35	1.93	1.80	1.86
Speed/Torque Gradient	rpm/oz-in	250.0	213.7	257.0	88.9	90.6	93.3	50.6	49.6	46.7	39.9	36.8	40.2

Notes:

- Motor mounted to a 6" x 6" x 1/4" aluminum plate, still air.
- Maximum winding temperature of 155°C.
- Typical electrical specifications at 25°C.
- Motor Terminal Voltages are representative only; motors may be operated at voltages other than those listed in the table. For assistance please contact our applications engineer.
- Calculated (theoretical) speed/torque gradient.
- For MS (military style) connector, please specify connector housing and terminal.
- Data for informational purposes only. Should not be considered a binding performance agreement. For specific applications, please contact the factory.

*Many other custom mechanical options are available – consult factory.

**Many other winding options are available – consult factory.

Select your options below and place their code in its corresponding block as shown on page 5.

- | | | |
|---|--|---|
| <input type="checkbox"/> TERMINATION | <input type="checkbox"/> FEEDBACK OPTIONS | <input type="checkbox"/> OTHER OPTIONS |
| L – Leads (std) | H – Hall Effect (std) | D – Drive |
| C – Connector | | G – Gearhead |
| M – MS connector | | |

BN23 IP65 Typical Outline

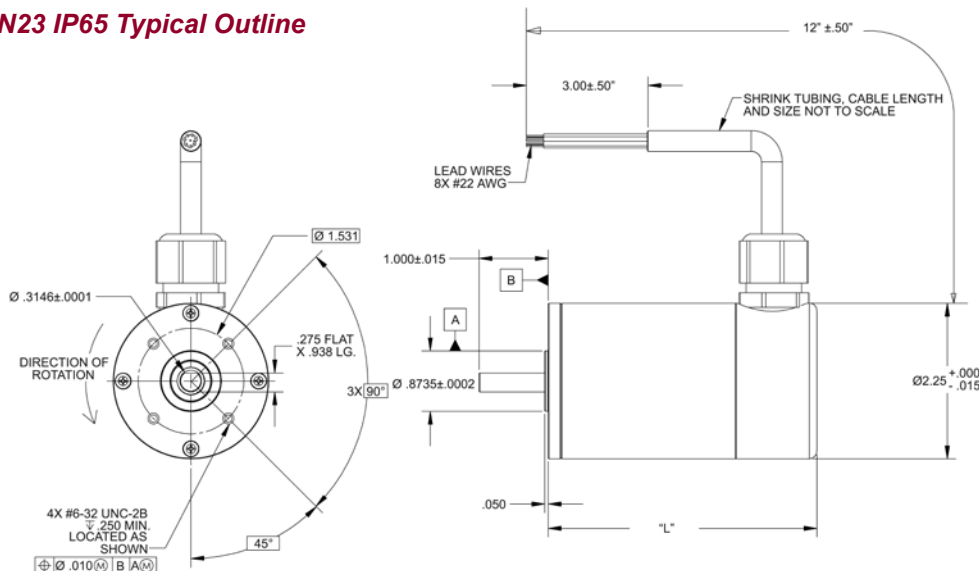

Termination Table*

COLOR	CONNECTION
VIOLET	A COIL
GREEN	C COIL
BLACK	B COIL
GRAY	HALL GND
YELLOW	HALL V _{CC}
WHITE	HALL S3
BLUE	HALL S2
BROWN	HALL S1

*We reserve the right to use solid color wires or white wires with color trace.

Dimensions are in inches

Inside Rotor Brushless Motors

BN23 IP65 Performance Curves

BN23 IP65 Performance Curves

BN23-13IP-01: Continuous & Intermittent Operation at 24 VDC

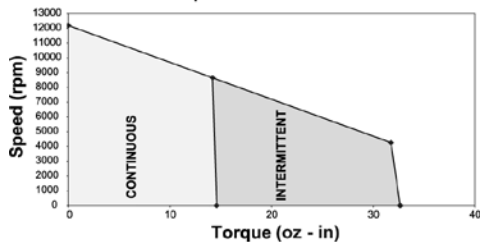

BN23-13IP-02: Continuous & Intermittent Operation at 36VDC

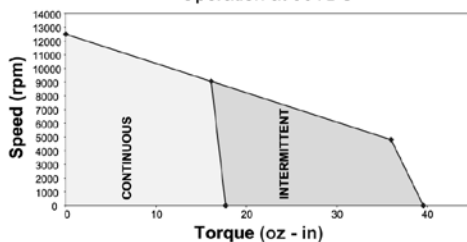

BN23-13IP-03: Continuous & Intermittent Operation at 48 VDC

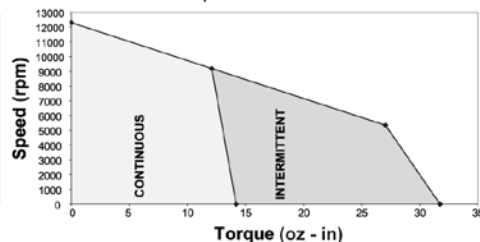

BN23-18IP-01: Continuous & Intermittent Operation at 24 VDC

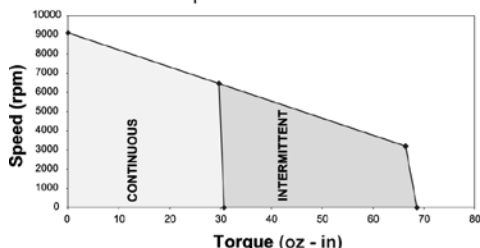

BN23-18IP-02: Continuous & Intermittent Operation at 36 VDC

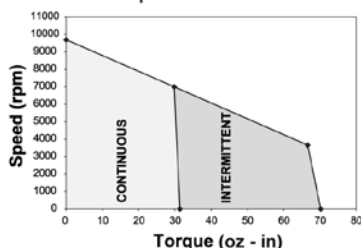

BN23-18IP-03: Continuous & Intermittent Operation at 48 VDC

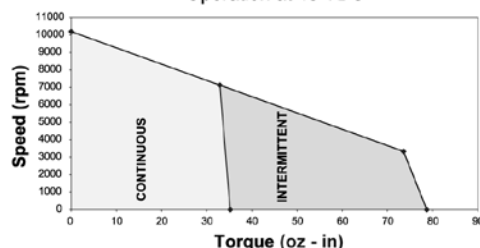

BN23-23IP-01: Continuous & Intermittent Operation at 24 VDC

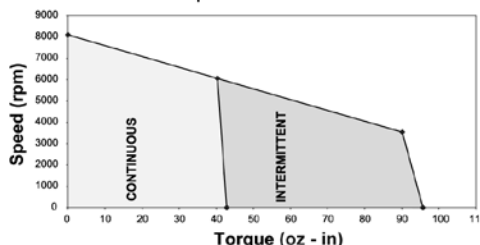

BN23-23IP-02: Continuous & Intermittent Operation at 36 VDC

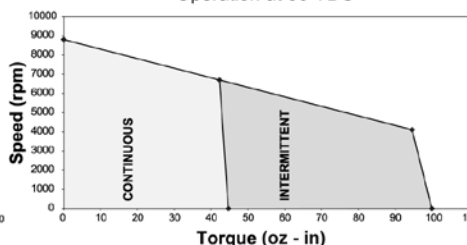

BN23-23IP-03: Continuous & Intermittent Operation at 48 VDC

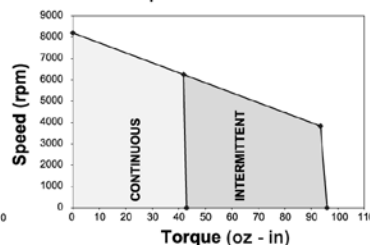

BN23-28IP-01: Continuous & Intermittent Operation at 24 VDC

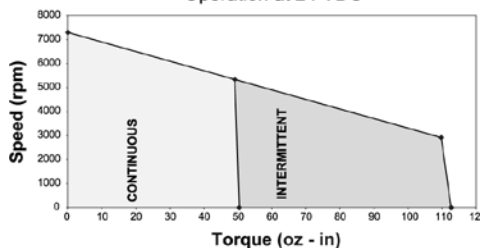

BN23-28IP-02: Continuous & Intermittent Operation at 36 VDC

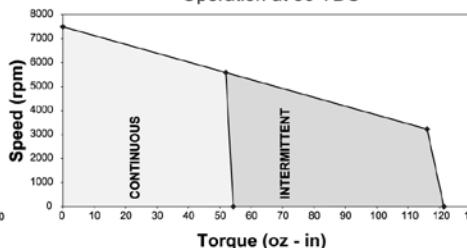

BN23-28IP-03: Continuous & Intermittent Operation at 48 VDC

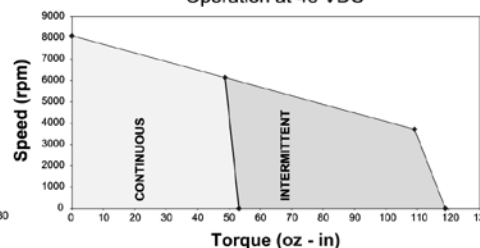

Note: Intermittent operation is based on a 20% duty cycle of one minute on, four minutes off. Please contact the factory regarding the duty cycle of your application.

BN28 Specifications

BN28 SPECIFICATIONS -

Continuous Stall Torque 43 - 108 oz-in (0.30 - 0.76 Nm)
Peak Torque 188 - 737 oz-in (1.33 - 5.2 Nm)

Inside Rotor
Brushless Motors

Part Number*		BN28-21AF- <input type="checkbox"/> <input type="checkbox"/> <input type="checkbox"/> <input type="checkbox"/> <input type="checkbox"/> <input type="checkbox"/>			BN28-29AF- <input type="checkbox"/> <input type="checkbox"/> <input type="checkbox"/> <input type="checkbox"/> <input type="checkbox"/> <input type="checkbox"/>			BN28-36AF- <input type="checkbox"/> <input type="checkbox"/> <input type="checkbox"/> <input type="checkbox"/> <input type="checkbox"/> <input type="checkbox"/>			BN28-44AF- <input type="checkbox"/> <input type="checkbox"/> <input type="checkbox"/> <input type="checkbox"/> <input type="checkbox"/> <input type="checkbox"/>		
Winding Code**		01	02	03	01	02	03	01	02	03	01	02	03
L = Length	inches	2.10			2.90			3.60			4.40		
	millimeters	53.3			73.7			91.4			111.8		
Terminal Voltage	volts DC	24.0	48.0	72.0	24.0	48.0	72.0	24.0	48.0	72.0	24.0	48.0	72.0
Peak Torque	oz-in	188.0	188.0	188.0	407.0	407.0	407.0	596.0	596.0	596.0	737.0	737.0	737.0
	Nm	1.3276	1.3276	1.3276	2.8740	2.8740	2.8740	4.2087	4.2087	4.2087	5.2043	5.2043	5.2043
Continuous Stall Torque	oz-in	43.0	44.0	46.0	71.0	74.0	72.0	93.0	95.0	93.0	106.0	108.0	105.0
	Nm	0.3036	0.3107	0.3248	0.5014	0.5226	0.5084	0.6567	0.6708	0.6567	0.7485	0.7626	0.7415
Rated Speed	RPM	9170	9230	9240	8870	8900	7890	5890	5910	5230	4660	4680	4120
	rad/sec	960	967	968	929	932	826	617	619	548	488	490	431
Rated Torque	oz-in	31	31	33	40	40	46	68	70	72	84	84	86
	Nm	0.2189	0.2189	0.2330	0.2825	0.2825	0.3248	0.4802	0.4943	0.5084	0.5932	0.5932	0.6073
Rated Current	Amps	10.26	5.13	3.63	12.67	6.33	4.29	14.31	7.35	4.51	14.25	7.13	4.35
Rated Power	watts	210.3	211.6	225.5	262.4	263.3	268.4	296.2	306.0	278.5	289.5	290.8	262.1
Torque Sensitivity	oz-in/amp	3.24	6.49	9.73	3.48	6.95	11.59	5.07	10.13	16.89	6.25	12.50	20.84
	Nm/amp	0.0229	0.0458	0.0687	0.0246	0.0491	0.0818	0.0358	0.0715	0.1193	0.0441	0.0883	0.1472
Back EMF	volts/KRPM	2.40	4.80	7.20	2.57	5.14	8.57	3.75	7.49	12.49	6.79	9.24	15.41
	volts/rad/sec	0.0229	0.0458	0.0687	0.0246	0.0491	0.0818	0.0358	0.0715	0.1193	0.048	0.0883	0.1472
Terminal Resistance	ohms	0.14	0.51	1.08	0.087	0.25	0.72	0.10	0.36	1.05	0.147	0.47	1.38
Terminal Inductance	mH	0.18	0.72	1.62	0.11	0.43	1.19	0.17	0.69	1.92	0.24	0.97	2.69
Motor Constant	oz-in/sq.rt.watt	8.72	9.06	9.38	13.44	13.93	13.69	16.45	16.86	16.49	17.82	18.18	17.73
	Nm/sq.rt.watt	0.062	0.064	0.066	0.095	0.098	0.097	0.116	0.119	0.11645	0.12584	0.12835	0.12518
Rotor Inertia	oz-in-sec ² x10 ⁻³	2.30	2.30	2.30	4.40	4.40	4.40	6.60	6.60	6.60	8.80	8.80	8.80
	g-cm ²	162.3	162.3	162.3	310.5	310.5	310.5	465.8	465.8	465.8	621.0	621.0	621.0
Weight	oz	23.0	23.0	23.0	35.0	35.0	35.0	48.0	48.0	48.0	61.0	61.0	61.0
	g	653.2	653.2	653.2	994.0	994.0	994.0	1363.2	1363.2	1363.2	1732.4	1732.4	1732.4
# of Poles		8.0	8.0	8.0	8.0	8.0	8.0	8.0	8.0	8.0	8.0	8.0	8.0
Timing		120°	120°	120°	120°	120°	120°	120°	120°	120°	120°	120°	120°
Mech. Time Constant	ms	4.3	4.0	3.7	3.4	3.2	3.3	3.5	3.3	3.4	3.9	3.8	4.0
Electrical Time Constant	ms	1.30	1.40	1.51	1.64	1.73	1.66	1.79	1.91	1.83	1.95	2.05	1.95
Thermal Resistivity	deg. C/watt	2.9	3.0	2.9	2.5	2.6	2.6	2.2	2.2	2.3	2.0	2.0	2.1
Speed/Torque Gradient	rpm/oz-in	47	47	47	25	25	25	20	20	20	13	13	13

Notes:

- Motor mounted to a 10 x 10 x 1/4 inches aluminum plate, still air.
- Maximum winding temperature of 155°C.
- Typical electrical specifications at 25°C.
- Motor Terminal Voltages are representative only; motors may be operated at voltages other than those listed in the table. For assistance please contact our applications engineer.
- For MS (military style) connector, please specify connector housing and terminal.
- Data for informational purposes only. Should not be considered a binding performance agreement. For specific applications, please contact the factory.

*Many other custom mechanical options are available – consult factory.

**Many other winding options are available – consult factory.

Select your options below and place their code in its corresponding block as shown on page 5.

- | | | |
|--|---|--|
| <input checked="" type="checkbox"/> TERMINATION | <input checked="" type="checkbox"/> FEEDBACK OPTIONS | <input checked="" type="checkbox"/> OTHER OPTIONS |
| L – Leads (std) | H – Hall Effect (std) | D – Drive |
| C – Connector | R – Resolver | E – Encoder |
| M – MS connector | S – Sensorless | G – Gearhead |

BN28 Housed / Frameless

Inside Rotor
Brushless Motors

BN28 Typical Outline - Housed

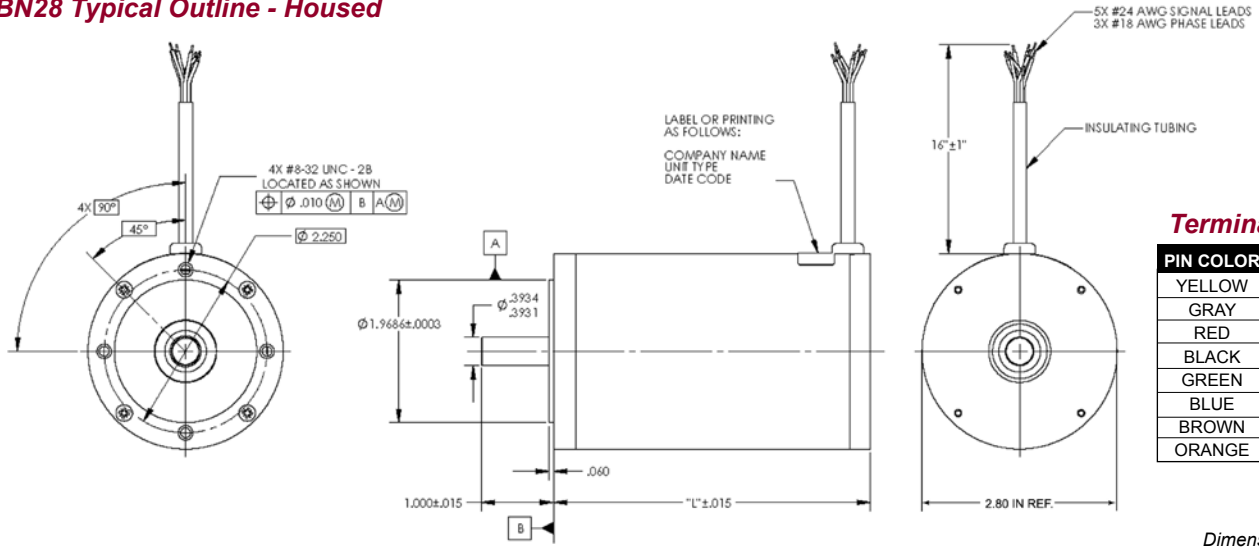

Termination Table

PIN COLOR	CONNECTION
YELLOW	V _{CC}
GRAY	GROUND
RED	A COIL
BLACK	B COIL
GREEN	C COIL
BLUE	S2 OUT
BROWN	S1 OUT
ORANGE	S3 OUT

Dimensions are in inches

BN28 Typical Outline - Frameless

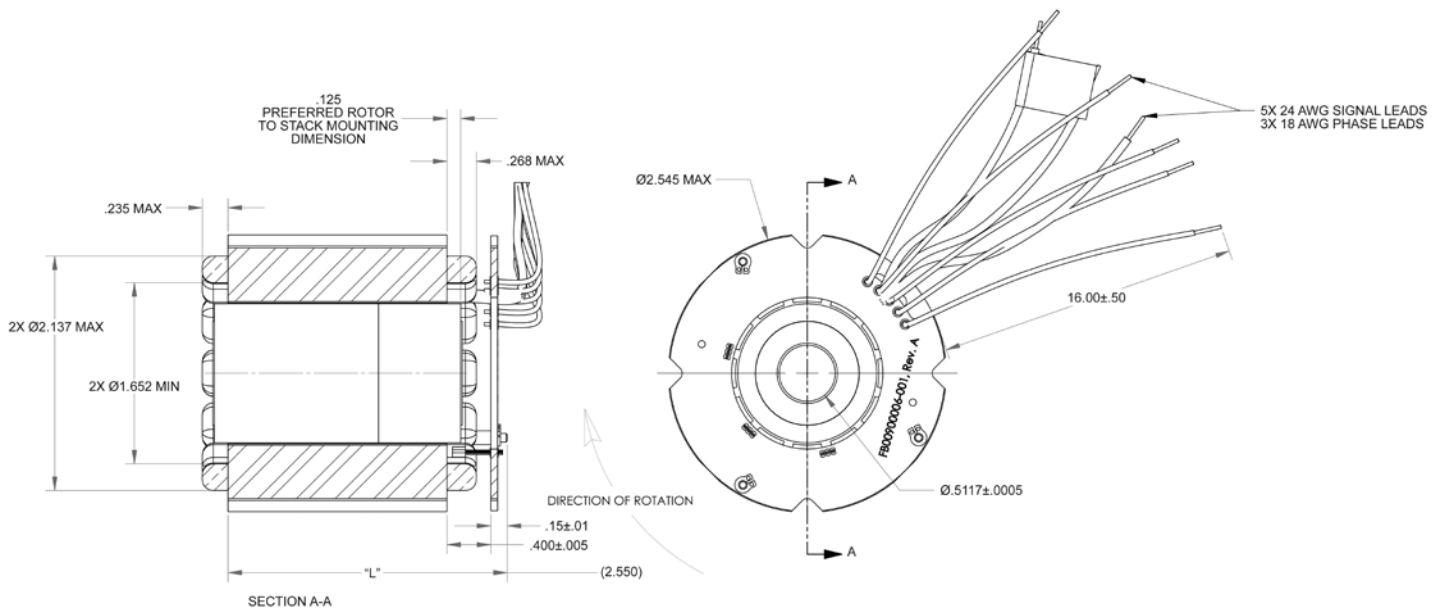

PART NUMBER	"L"
BN28-21ZP-XXLH	1.050
BN28-29ZP-XXLH	1.80
BN28-36ZP-XXLH	2.550
BN28-44ZP-XXLH	3.300

Note: For electrical performance see page 24.

Dimensions are in inches

BN28 Performance Curves

BN28 Performance Curves

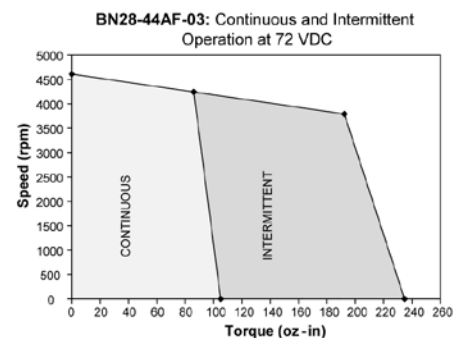
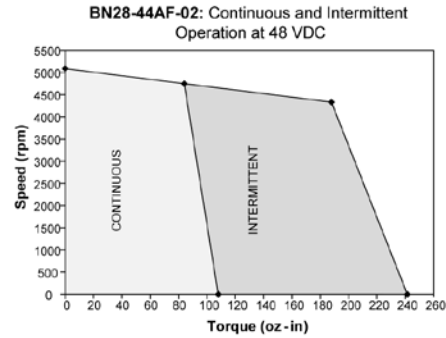
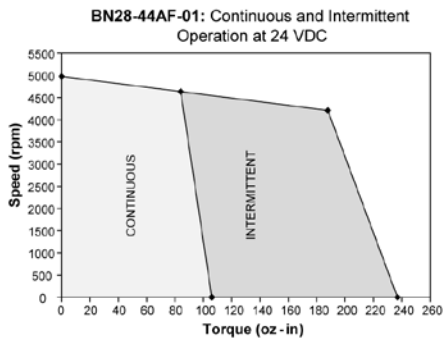
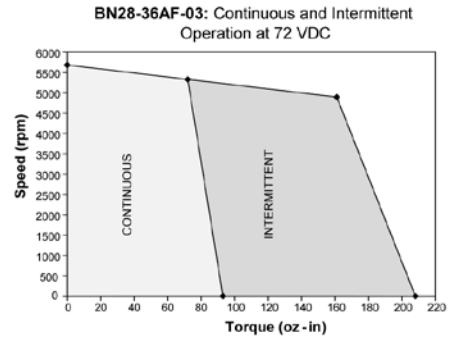
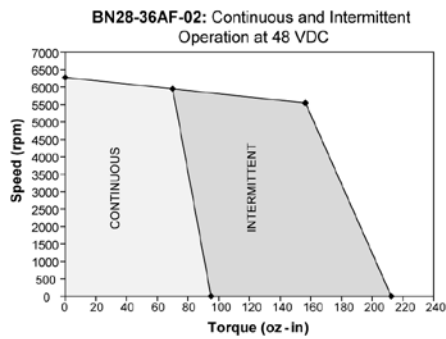
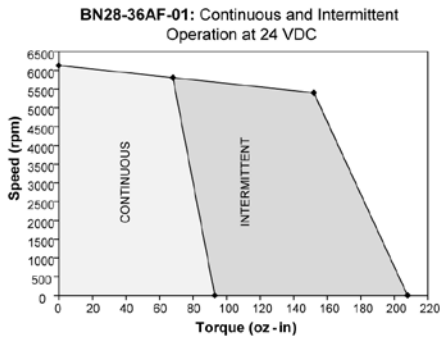
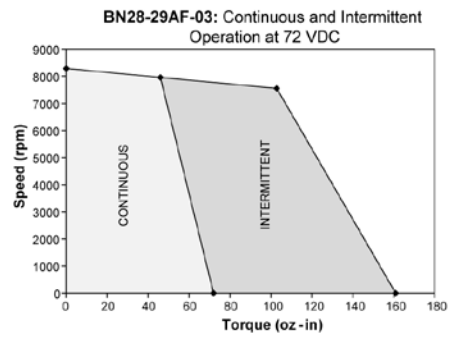
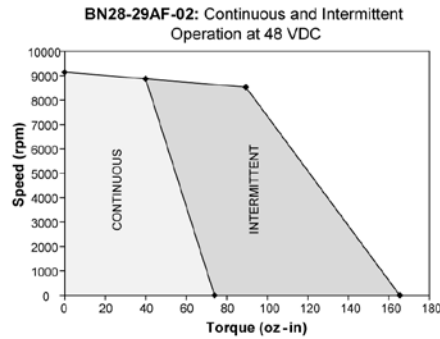
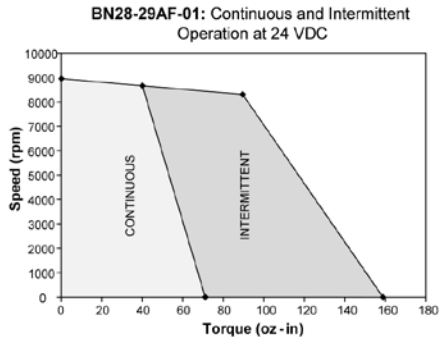
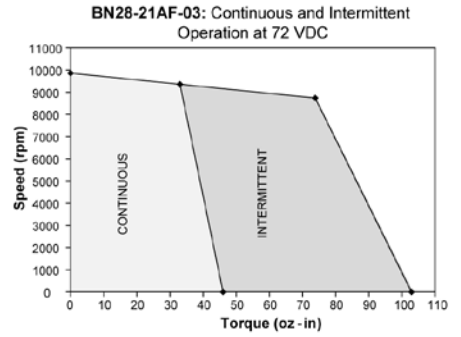
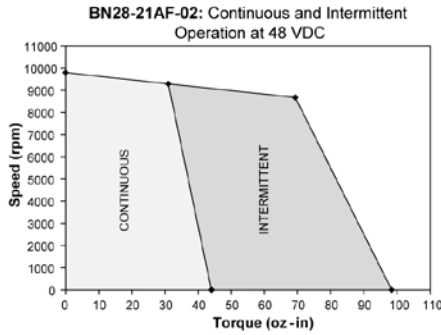
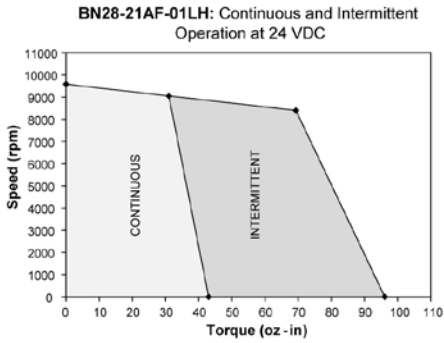

Note: Intermittent operation is based on a 20% duty cycle of one minute on, four minutes off.
Please contact the factory regarding the duty cycle of your application.

BN28 IP65 Specifications

BN28 IP65 SPECIFICATIONS - Continuous Stall Torque 43 - 108 oz-in (0.30 - 0.76 Nm)
Peak Torque 188 - 737 oz-in (1.33 - 5.2 Nm)

Inside Rotor
Brushless Motors

Part Number*		BN28-21IP - <input type="checkbox"/> <input type="checkbox"/> <input type="checkbox"/> <input type="checkbox"/> <input type="checkbox"/> <input type="checkbox"/>			BN28-29IP - <input type="checkbox"/> <input type="checkbox"/> <input type="checkbox"/> <input type="checkbox"/> <input type="checkbox"/> <input type="checkbox"/>			BN28-36IP - <input type="checkbox"/> <input type="checkbox"/> <input type="checkbox"/> <input type="checkbox"/> <input type="checkbox"/> <input type="checkbox"/>			BN28-44IP - <input type="checkbox"/> <input type="checkbox"/> <input type="checkbox"/> <input type="checkbox"/> <input type="checkbox"/> <input type="checkbox"/>		
Winding Code**		01	02	03	01	02	03	01	02	03	01	02	03
L = Length	inches	2.10			2.90			3.60			4.40		
	millimeters	53.3			73.7			91.4			111.8		
Terminal Voltage	volts DC	24.0	48.0	72.0	24.0	48.0	72.0	24.0	48.0	72.0	24.0	48.0	72.0
Peak Torque	oz-in	188.0	188.0	188.0	407.0	407.0	407.0	596.0	596.0	596.0	737.0	737.0	737.0
	Nm	1.3276	1.3276	1.3276	2.8740	2.8740	2.8740	4.2087	4.2087	4.2087	5.2043	5.2043	5.2043
Continuous Stall Torque	oz-in	43.0	44.0	46.0	71.0	74.0	72.0	93.0	95.0	93.0	106.0	108.0	105.0
	Nm	0.3036	0.3107	0.3248	0.5014	0.5226	0.5084	0.6567	0.6708	0.6567	0.7485	0.7626	0.7415
Rated Speed	RPM	9170	9230	9240	8870	8900	7890	5890	5910	5230	4660	4680	4120
	rad/sec	960	967	968	929	932	826	617	619	548	488	490	431
Rated Torque	oz-in	31	31	33	40	40	46	68	70	72	84	84	86
	Nm	0.2189	0.2189	0.2330	0.2825	0.2825	0.3248	0.4802	0.4943	0.5084	0.5932	0.5932	0.6073
Rated Current	Amps	10.26	5.13	3.63	12.67	6.33	4.29	14.31	7.35	4.51	14.25	7.13	4.35
Rated Power	watts	210.3	211.6	225.5	262.4	263.3	268.4	296.2	306.0	278.5	289.5	290.8	262.1
Torque Sensitivity	oz-in/amp	3.24	6.49	9.73	3.48	6.95	11.59	5.07	10.13	16.89	6.79	12.50	20.84
	Nm/amp	0.0229	0.0458	0.0687	0.0246	0.0491	0.0818	0.0358	0.0715	0.1193	0.048	0.0883	0.1472
Back EMF	volts/KRPM	2.40	4.80	7.20	2.57	5.14	8.57	3.75	7.49	12.49	5.02	9.24	15.41
	volts/rad/sec	0.0229	0.0458	0.0687	0.0246	0.0491	0.0818	0.0358	0.0715	0.1193	0.048	0.0883	0.1472
Terminal Resistance	ohms	0.14	0.51	1.08	0.087	0.25	0.72	0.10	0.36	1.05	0.147	0.47	1.38
Terminal Inductance	mH	0.18	0.72	1.62	0.11	0.43	1.19	0.17	0.69	1.92	0.24	0.97	2.69
Motor Constant	oz-in/sq.rt.watt	8.72	9.06	9.38	13.44	13.93	13.69	16.45	16.86	16.49	17.82	18.18	17.73
	Nm/sq.rt.watt	0.062	0.064	0.066	0.095	0.098	0.097	0.116	0.119	0.11645	0.12584	0.12835	0.12518
Rotor Inertia	oz-in-sec ² x10 ⁻³	2.30	2.30	2.30	4.40	4.40	4.40	6.60	6.60	6.60	8.80	8.80	8.80
	g-cm ²	162.3	162.3	162.3	310.5	310.5	310.5	465.8	465.8	465.8	621.0	621.0	621.0
Weight	oz	23.0	23.0	23.0	35.0	35.0	35.0	48.0	48.0	48.0	61.0	61.0	61.0
	g	653.2	653.2	653.2	994.0	994.0	994.0	1363.2	1363.2	1363.2	1732.4	1732.4	1732.4
# of Poles		8.0	8.0	8.0	8.0	8.0	8.0	8.0	8.0	8.0	8.0	8.0	8.0
Timing		120°	120°	120°	120°	120°	120°	120°	120°	120°	120°	120°	120°
Mech. Time Constant	ms	4.3	4.0	3.7	3.4	3.2	3.3	3.5	3.3	3.4	3.9	3.8	4.0
Electrical Time Constant	ms	1.30	1.40	1.51	1.64	1.73	1.66	1.79	1.91	1.83	1.95	2.05	1.95
Thermal Resistivity	deg. C/watt	2.9	3.0	2.9	2.5	2.6	2.6	2.2	2.2	2.3	2.0	2.0	2.1
Speed/Torque Gradient	rpm/oz-in	47	47	47	25	25	25	20	20	20	13	13	13

Notes:

- Motor mounted to a 10 x 10 x 1/4 inches aluminum plate, still air.
- Maximum winding temperature of 155°C.
- Typical electrical specifications at 25°C.
- Motor Terminal Voltages are representative only; motors may be operated at voltages other than those listed in the table. For assistance please contact our applications engineer.
- Calculated (theoretical) speed/torque gradient.
- For MS (military style) connector, please specify connector housing and terminal.
- Data for informational purposes only. Should not be considered a binding performance agreement. For specific applications, please contact the factory.

*Many other custom mechanical options are available – consult factory.
**Many other winding options are available – consult factory.

Select your options below and place their code in its corresponding block as shown on page 5.

- | | | |
|---|--|---|
| <input type="checkbox"/> TERMINATION | <input type="checkbox"/> FEEDBACK OPTIONS | <input type="checkbox"/> OTHER OPTIONS |
| L – Leads (std) | H – Hall Effect (std) | D – Drive |
| C – Connector | R – Resolver | E – Encoder |
| M – MS connector | S – Sensorless | G – Gearhead |

BN28 IP65 Typical Outline

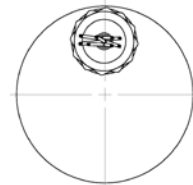
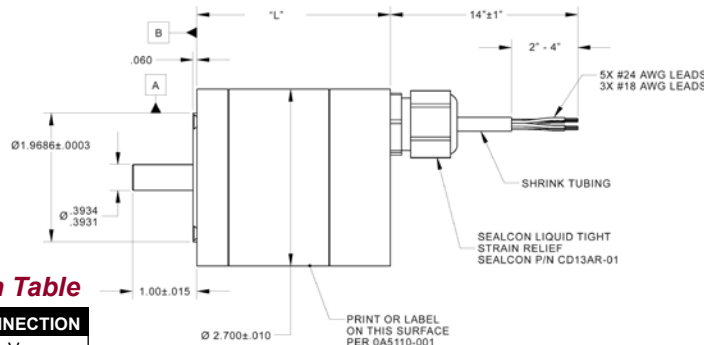
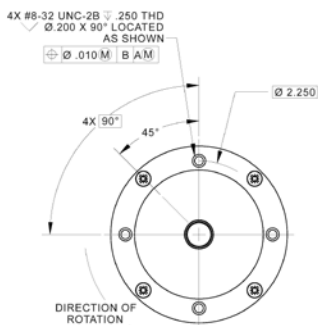

Dimensions are in inches

Termination Table

PIN COLOR	CONNECTION
YELLOW	Vcc
GRAY	GROUND
RED	A COIL
BLACK	B COIL
GREEN	C COIL
BLUE	S2 OUT
BROWN	S1 OUT
ORANGE	S3 OUT

BN28 IP65 Performance Curves

Inside Rotor
Brushless Motors

BN28 IP65 Performance Curves

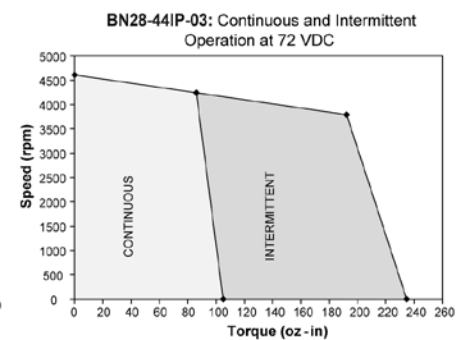
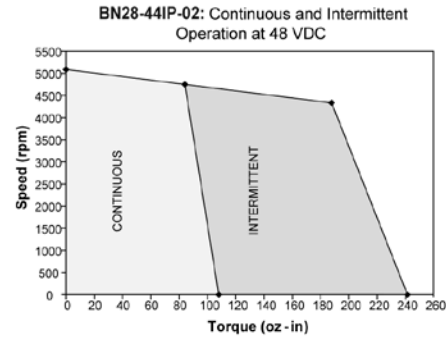
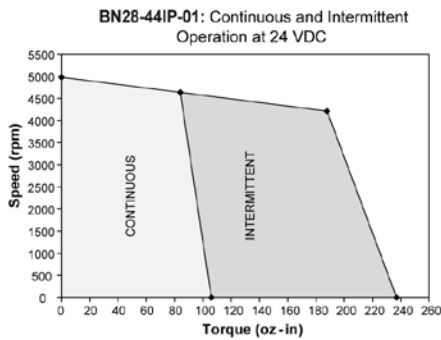
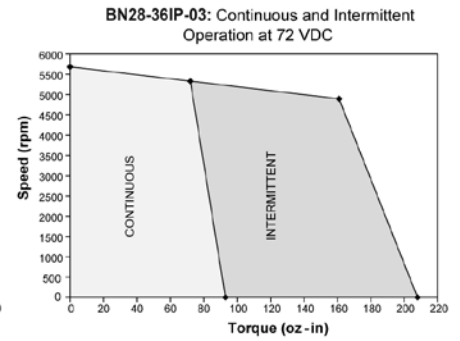
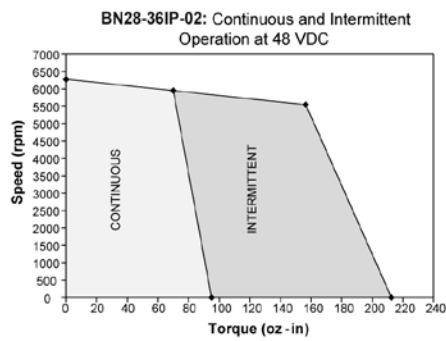
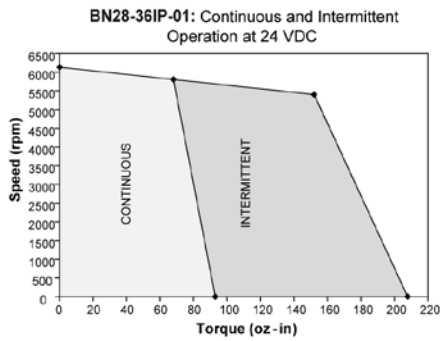
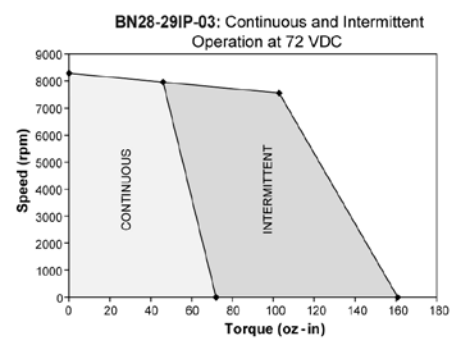
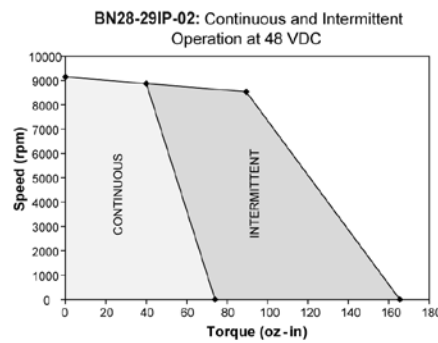
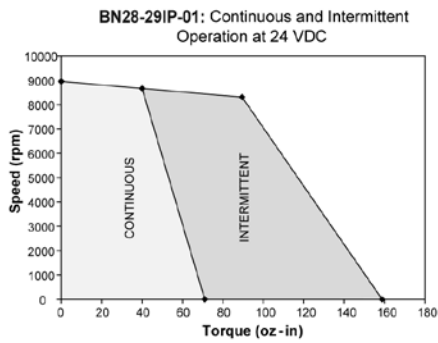
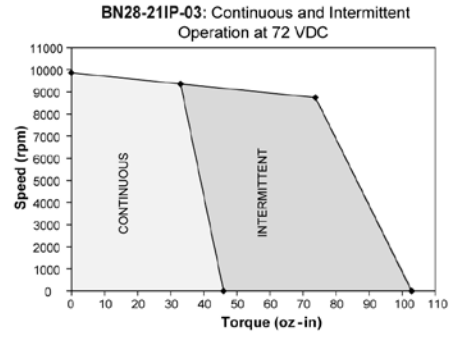
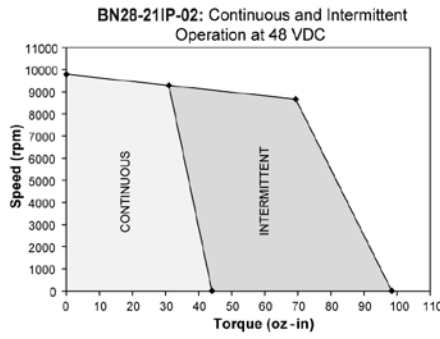
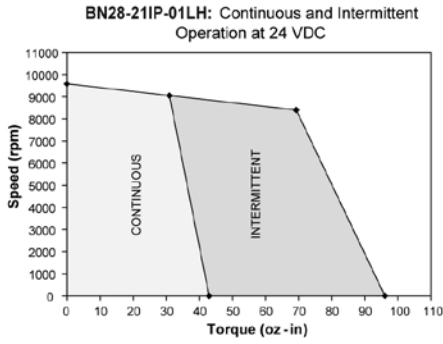

Note: Intermittent operation is based on a 20% duty cycle of one minute on, four minutes off.
Please contact the factory regarding the duty cycle of your application.

BN34 Specifications

BN34 SPECIFICATIONS - Continuous Stall Torque 83 - 309 oz-in (0.587 - 2.19 Nm) Peak Torque 326 - 1445 oz-in (2.31 - 10.21 Nm)

Inside Rotor
Brushless Motors

Part Number*		BN34-25AF- <input type="checkbox"/> <input type="checkbox"/> <input type="checkbox"/> <input type="checkbox"/> <input type="checkbox"/> <input type="checkbox"/> <input type="checkbox"/> <input type="checkbox"/>			BN34-35AF- <input type="checkbox"/> <input type="checkbox"/> <input type="checkbox"/> <input type="checkbox"/> <input type="checkbox"/> <input type="checkbox"/> <input type="checkbox"/> <input type="checkbox"/>			BN34-45AF- <input type="checkbox"/> <input type="checkbox"/> <input type="checkbox"/> <input type="checkbox"/> <input type="checkbox"/> <input type="checkbox"/> <input type="checkbox"/> <input type="checkbox"/>			BN34-55AF- <input type="checkbox"/> <input type="checkbox"/> <input type="checkbox"/> <input type="checkbox"/> <input type="checkbox"/> <input type="checkbox"/> <input type="checkbox"/> <input type="checkbox"/>		
Winding Code**		01	02	03	01	02	03	01	02	03	01	02	03
L = Length	inches	2.5			3.5			4.5			5.5		
	millimeters	63.5			88.9			114.3			139.7		
Terminal Voltage	volts DC	24	50	100	24	50	100	24	50	100	24	50	100
Peak Torque	oz-in	310	310	310	657	643	657	1006	1006	1006	1375	1375	1375
	Nm	2.19	2.19	2.19	4.64	4.5405	4.64	7.11	7.11	7.11	9.71	9.71	9.71
Continuous Stall Torque	oz-in	88	93	90	140	162	172	210	220	236	249	288	299
	Nm	0.62	0.66	0.64	0.99	1.144	1.21	1.49	1.55	1.67	1.76	2.03	2.11
Rated Speed	RPM	8130	7500	7280	6010	6400	6380	3800	5170	5270	2750	4350	4360
	rad/sec	851	785	762	629	670	667	397	541	552	288	455	456
Rated Torque	oz-in	60	64	62	93	106	110	172	148	170	214	208	214
	Nm	0.4237	0.45	0.44	0.6567	0.749	0.78	1.24	1.05	1.2005	1.51	1.49	1.51
Rated Current	Amps	16.98	8	3.77	18.74	11	5.8	23.1	12.6	7	21.16	14.85	7.63
Rated Power	watts	361	355	334	417	502	519	483	567	612	435	669	690
Torque Sensitivity	oz-in/amp	3.78	8.5	17.48	5.06	9.92	20.26	7.76	12.42	26.39	10.5	14.7	29.39
	Nm/amp	0.027	0.06	0.123	0.036	0.0701	0.142	0.055	0.088	0.186	0.074	0.104	0.208
Back EMF	volts/KRPM	2.79	6.29	12.92	3.74	7.34	14.98	5.74	9.18	19.51	7.76	10.87	21.73
	volts/rad/sec	0.027	0.06	0.123	0.036	0.07	0.143	0.055	0.088	0.186	0.074	0.104	0.208
Terminal Resistance	ohms	0.079	0.253	1.12	0.05	0.147	0.548	0.068	0.141	0.557	0.088	0.131	0.487
Terminal Inductance	mH	0.12	0.62	2.62	0.1	0.43	1.72	0.17	0.43	1.94	0.23	0.44	1.78
Motor Constant	oz-in/sq.rt.watt	13.44	16.11	16.51	22.63	25.87	27.37	29.75	33.06	35.36	35.4	40.61	42.11
	Nm/sq.rt.watt	0.11	0.11	0.12	0.16	0.183	0.19	0.22	0.23	0.25	0.25	0.29	0.3
Rotor Inertia	oz-in-sec ² x10 ⁻³	7.2	7.2	7.2	14.1	12	14	21	21	21	28	28	28
	g-cm ²	510	510	510	1000	846.8	1000	1500	1500	1500	2000	2000	2000
Weight	oz	36	37	36	62	62	62	87	89	89	114	116	116
	g	1020	1030	1030	1750	1760.8	1770	2480	2520	2530	3230	3300	3.3
# of Poles		8	8	8	8	8	8	8	8	8	8	8	8
Timing		120°	120°	120°	120°	120°	120°	120°	120°	120°	120°	120°	120°
Mech. Time Constant	ms	3.87	3.58	3.75	3.96	2.5	2.7	3.38	2.75	2.41	3.2	2.43	2.26
Electrical Time Constant	ms	2.27	2.45	2.34	2.14	2.9	3.15	2.48	3.04	3.48	2.58	3.4	3.66
Thermal Resistivity	deg. C/watt	2.25	2.39	2.41	1.87	1.84	1.84	1.51	1.63	1.62	1.45	1.43	1.43
Speed/Torque Gradient	rpm/oz-in	5.3	4.3	4.3	2.8	2.8	1.8	1.1	1	1	0.8	0.7	0.6

Notes:

- Motor mounted to a 10 x 10 x 1/4 inches aluminum plate, still air.
- Maximum winding temperature of 155°C.
- Typical electrical specifications at 25°C.
- Motor Terminal Voltages are representative only; motors may be operated at voltages other than those listed in the table. For assistance please contact our applications engineer.
- For MS (military style) connector, please specify connector housing and terminal.
- Data for informational purposes only. Should not be considered a binding performance agreement. For specific applications, please contact the factory.

*Many other custom mechanical options are available – consult factory.

**Many other winding options are available – consult factory.

Select your options below and place their code in its corresponding block as shown on page 5.

- | | | |
|--|---|--|
| <input checked="" type="checkbox"/> TERMINATION | <input checked="" type="checkbox"/> FEEDBACK OPTIONS | <input checked="" type="checkbox"/> OTHER OPTIONS |
| L – Leads (std) | H – Hall Effect (std) | D – Drive |
| C – Connector | R – Resolver | E – Encoder |
| M – MS connector | S – Sensorless | G – Gearhead |

BN34 Housed / Frameless

Inside Rotor
Brushless Motors

BN34 Typical Outline - Housed

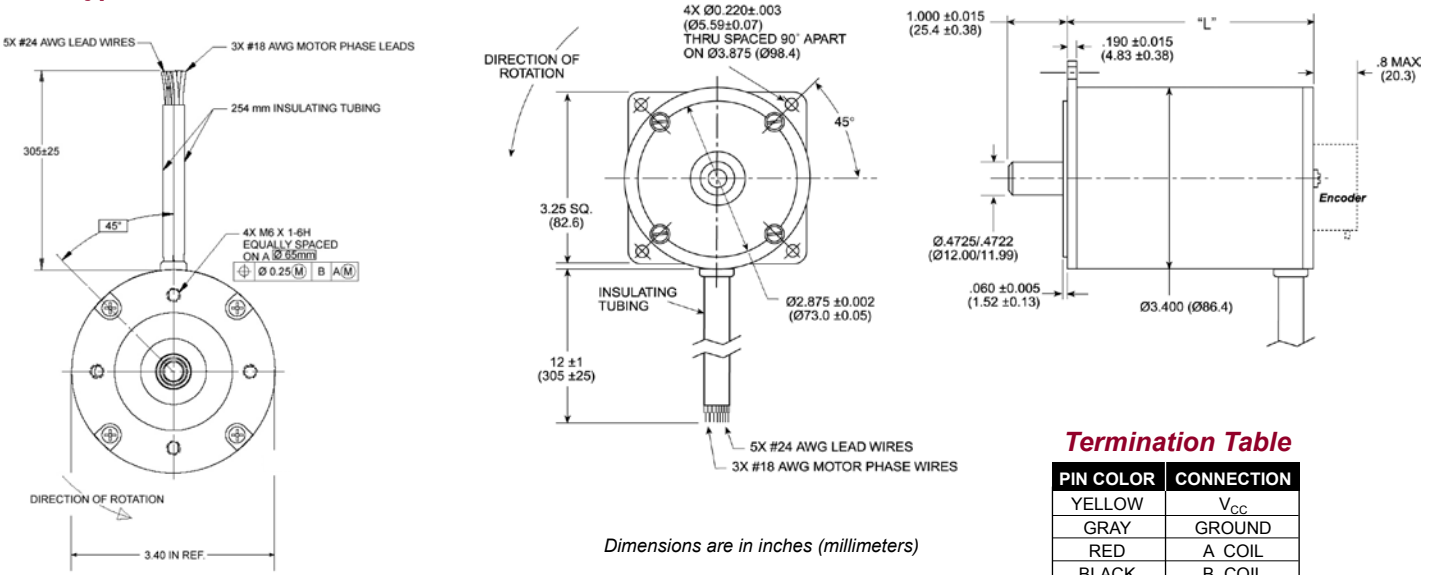

Termination Table

PIN COLOR	CONNECTION
YELLOW	V _{CC}
GRAY	GROUND
RED	A COIL
BLACK	B COIL
GREEN	C COIL
BLUE	S2 OUT
BROWN	S1 OUT
ORANGE	S3 OUT

BN34 Typical Outline - Frameless

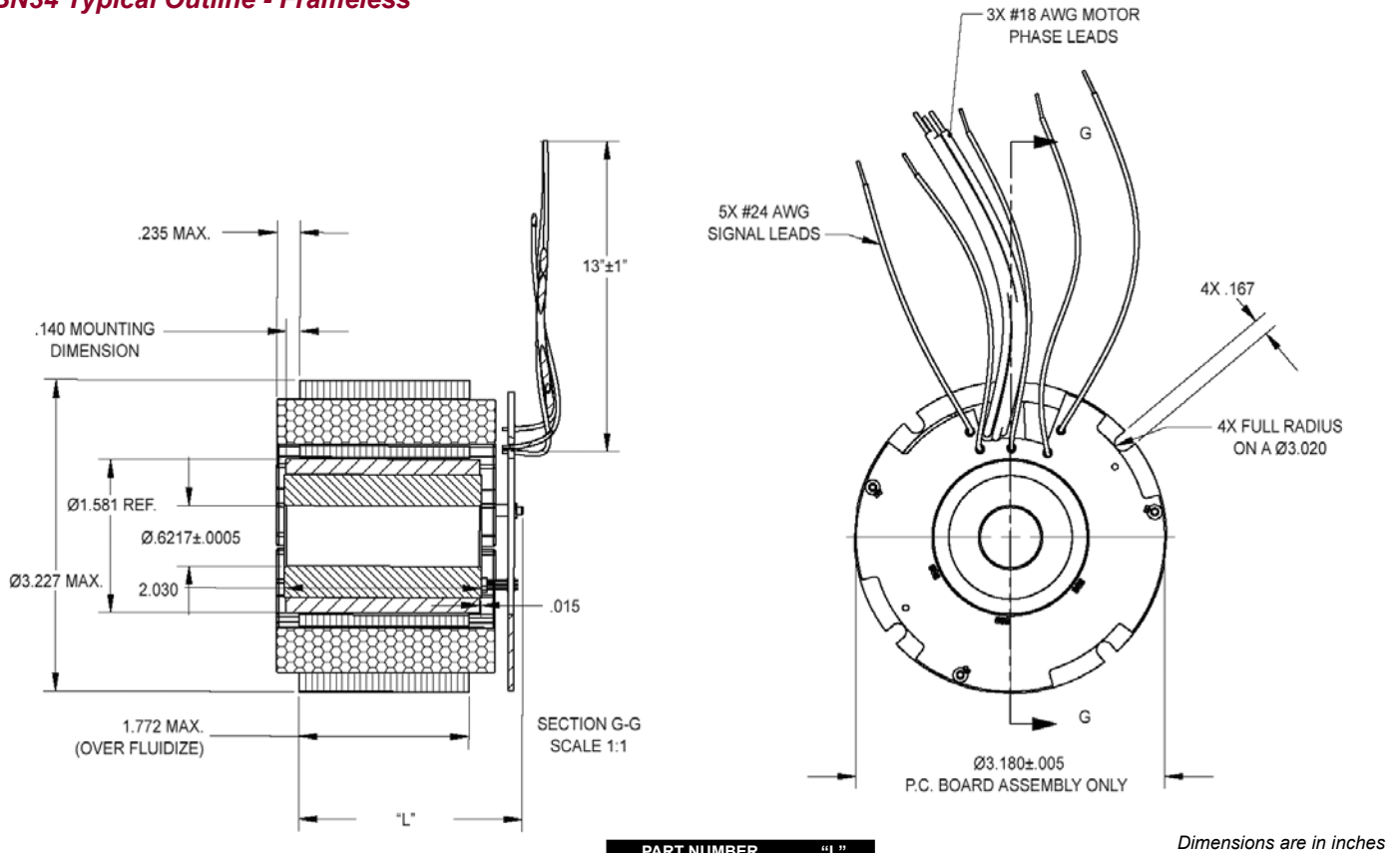

PART NUMBER	"L"
BN34-25ZP-[] [-LH]	1.337
BN34-35ZP-[] [-LH]	2.337
BN34-45ZP-[] [-LH]	3.337
BN34-55ZP-[] [-LH]	4.337

Note: See page 29 for performance data.

BN34 Performance Curves

BN34 Performance Curves

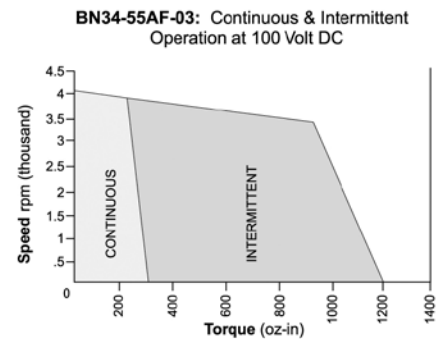
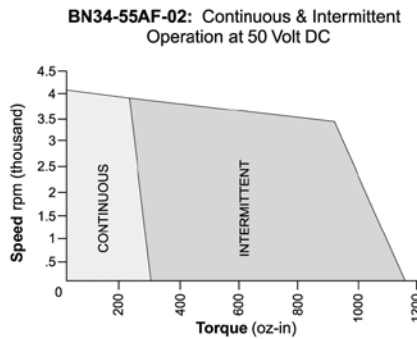
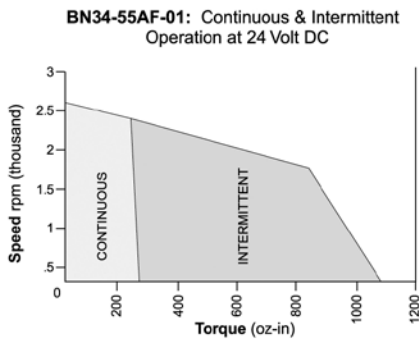
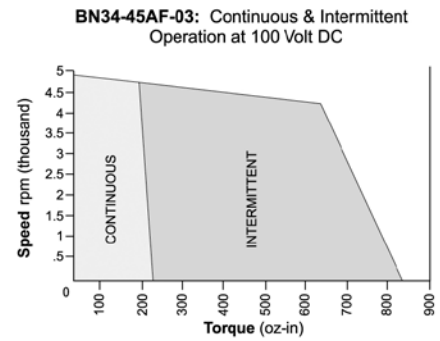
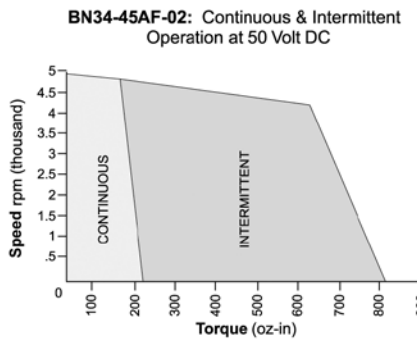
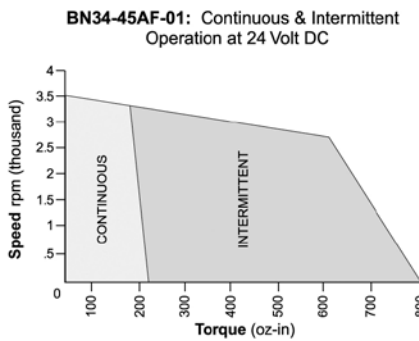
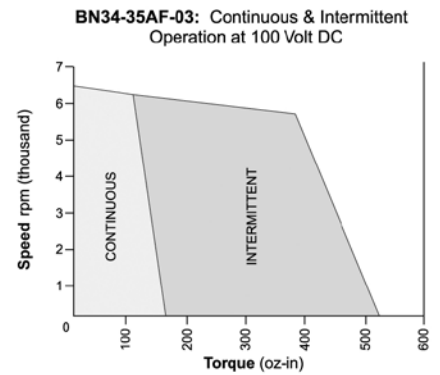
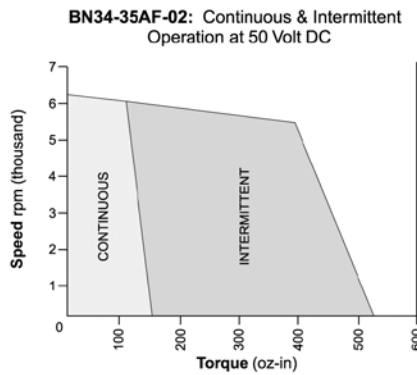
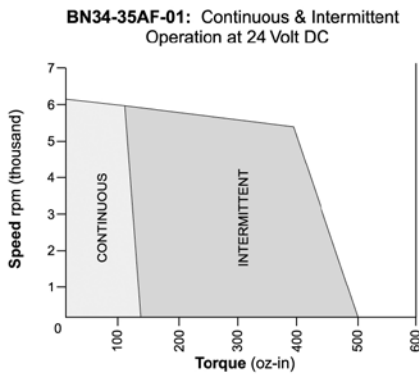
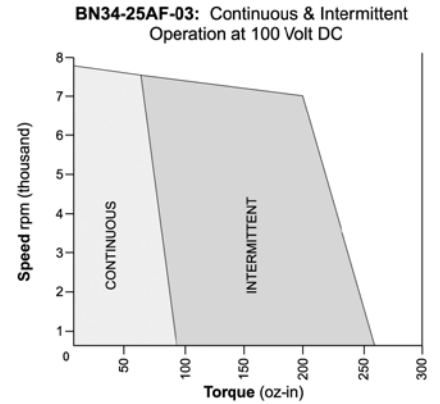
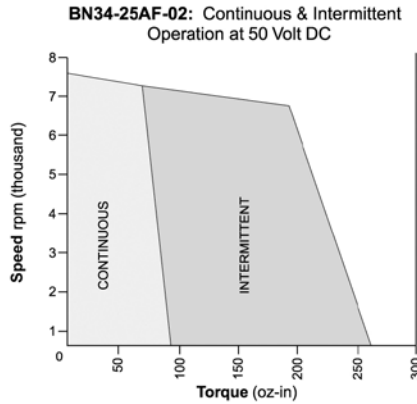
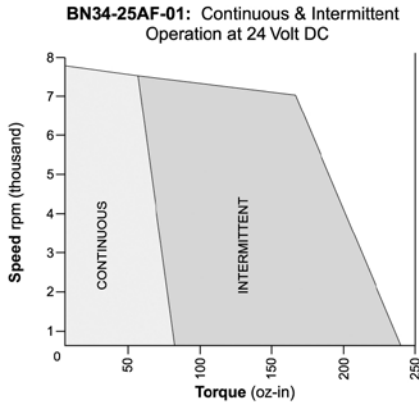

Note: Intermittent operation is based on a 20% duty cycle of one minute on, four minutes off.
Please contact the factory regarding the duty cycle of your application.

BN34 EU Specifications

Inside Rotor
Brushless Motors

BN34 EU SPECIFICATIONS -

Continuous Stall Torque 83 - 309 oz-in (0.587 - 2.19 Nm)
Peak Torque 326 - 1445 oz-in (2.31 - 10.21 Nm)

Part Number*		BN34-25EU- <input type="checkbox"/> <input type="checkbox"/> <input type="checkbox"/> <input type="checkbox"/>			BN34-35EU- <input type="checkbox"/> <input type="checkbox"/> <input type="checkbox"/> <input type="checkbox"/>			BN34-45EU- <input type="checkbox"/> <input type="checkbox"/> <input type="checkbox"/> <input type="checkbox"/>			BN34-55EU- <input type="checkbox"/> <input type="checkbox"/> <input type="checkbox"/> <input type="checkbox"/>		
Winding Code**		01	02	03	01	02	03	01	02	03	01	02	03
L = Length	inches	2.5			3.5			4.5			5.5		
	millimeters	63.5			88.9			114.3			139.7		
Terminal Voltage	volts DC	24	50	100	24	50	100	24	50	100	24	50	100
Peak Torque	oz-in	310	310	310	657	643	657	1006	1006	1006	1375	1375	1375
	Nm	2.19	2.19	2.19	4.64	4.5405	4.64	7.11	7.11	7.11	9.71	9.71	9.71
Continuous Stall Torque	oz-in	88	93	90	140	162	172	210	220	236	249	288	299
	Nm	0.62	0.66	0.64	0.99	1.144	1.21	1.49	1.55	1.67	1.76	2.03	2.11
Rated Speed	RPM	8130	7500	7280	6010	6400	6380	3800	5170	5270	2750	4350	4360
	rad/sec	851	785	762	629	670	667	397	541	552	288	455	456
Rated Torque	oz-in	60	64	62	93	106	110	172	148	170	214	208	214
	Nm	0.4237	0.45	0.44	0.6567	0.749	0.78	1.24	1.05	1.2005	1.51	1.49	1.51
Rated Current	Amps	16.98	8	3.77	18.74	11	5.8	23.1	12.6	7	21.16	14.85	7.63
Rated Power	watts	361	355	334	417	502	519	483	567	612	435	669	690
Torque Sensitivity	oz-in/amp	3.78	8.5	17.48	5.06	9.92	20.26	7.76	12.42	26.39	10.5	14.7	29.39
	Nm/amp	0.027	0.06	0.123	0.036	0.0701	0.142	0.055	0.088	0.186	0.074	0.104	0.208
Back EMF	volts/KRPM	2.79	6.29	12.92	3.74	7.34	14.98	5.74	9.18	19.51	7.76	10.87	21.73
	volts/rad/sec	0.027	0.06	0.123	0.036	0.07	0.143	0.055	0.088	0.186	0.074	0.104	0.208
Terminal Resistance	ohms	0.079	0.253	1.12	0.05	0.147	0.548	0.068	0.141	0.557	0.088	0.131	0.487
Terminal Inductance	mH	0.12	0.62	2.62	0.1	0.43	1.72	0.17	0.43	1.94	0.23	0.44	1.78
Motor Constant	oz-in/sq.rt.watt	13.44	16.11	16.51	22.63	25.87	27.37	29.75	33.06	35.36	35.4	40.61	42.11
	Nm/sq.rt.watt	0.11	0.11	0.12	0.16	0.183	0.19	0.22	0.23	0.25	0.25	0.29	0.3
Rotor Inertia	oz-in-sec ²	7.2	7.2	7.2	14.1	12	14	21	21	21	28	28	28
	g-cm ²	510	510	510	1000	846.8	1000	1500	1500	1500	2000	2000	2000
Weight	oz	36	37	36	62	62	62	87	89	89	114	116	116
	g	1020	1030	1030	1750	1760.8	1770	2480	2520	2530	3230	3300	3.3

Notes:

- Motor mounted to a 10 x 10 x 1/4 inches aluminum plate, still air.
- Maximum winding temperature of 155°C.
- Typical electrical specifications at 25°C.
- Motor Terminal Voltages are representative only; motors may be operated at voltages other than those listed in the table. For assistance please contact our applications engineer.
- For MS (military style) connector, please specify connector housing and terminal.
- Data for informational purposes only. Should not be considered a binding performance agreement. For specific applications, please contact the factory.

*Many other custom mechanical options are available – consult factory.

**Many other winding options are available – consult factory.

Select your options below and place their code in its corresponding block as shown on page 5.

- | | | |
|---|--|---|
| <input type="checkbox"/> TERMINATION | <input type="checkbox"/> FEEDBACK OPTIONS | <input type="checkbox"/> OTHER OPTIONS |
| L – Leads (std) | H – Hall Effect (std) | D – Drive |
| C – Connector | R – Resolver | E – Encoder |
| M – MS connector | S – Sensorless | G – Gearhead |

BN34 EU Typical Outline

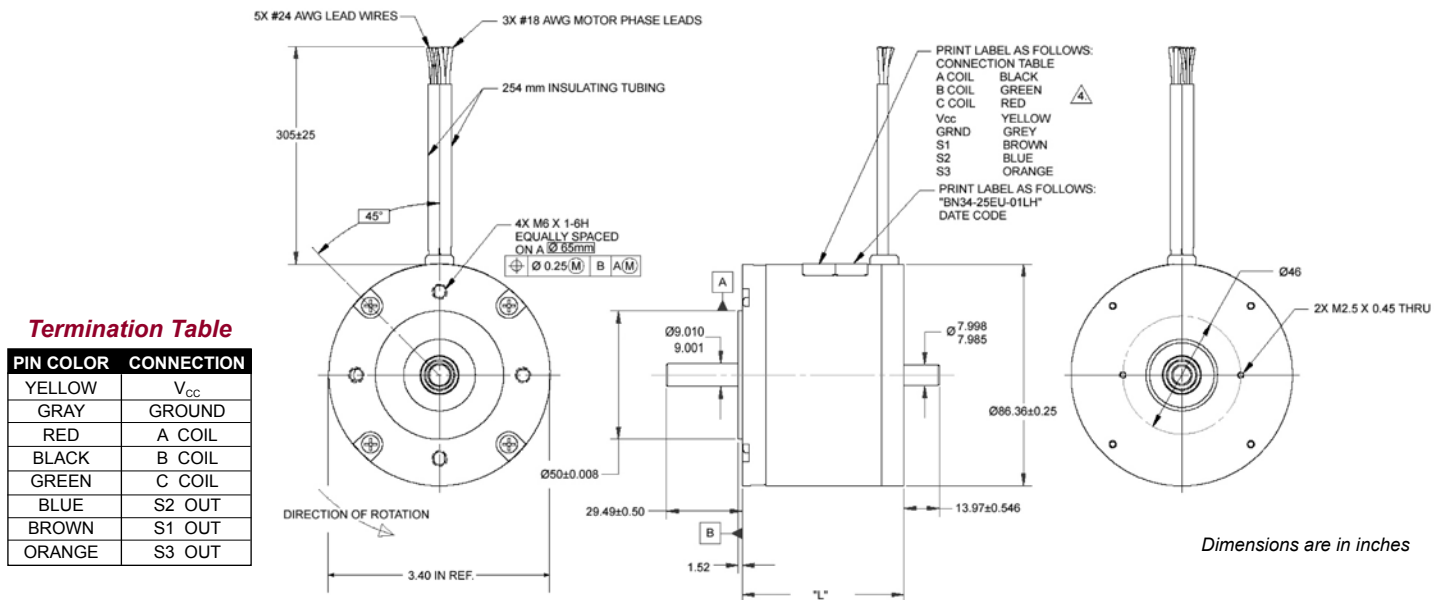

BN34 EU Performance Curves

BN34 EU Performance Curves

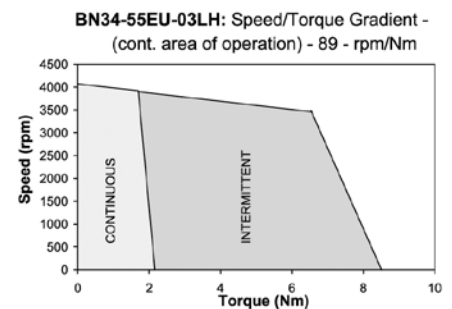
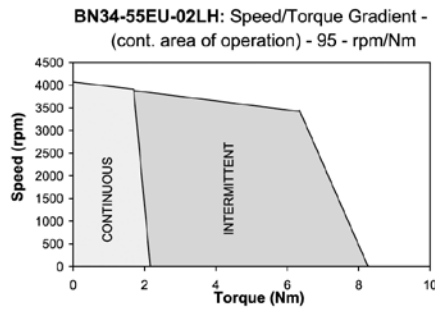
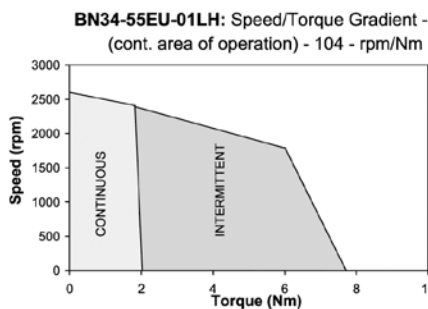
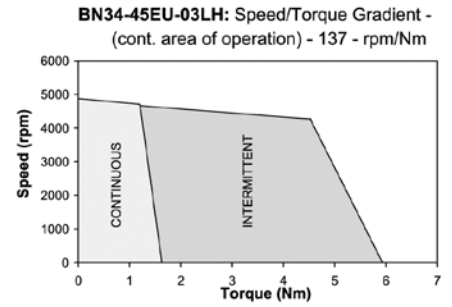
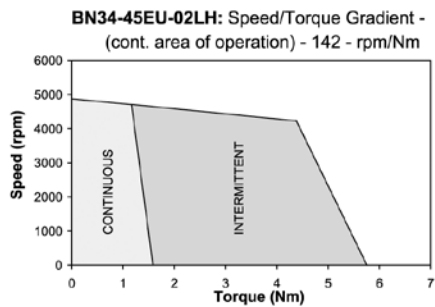
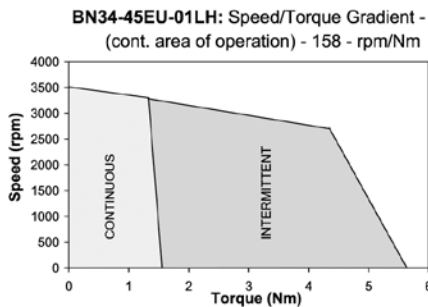
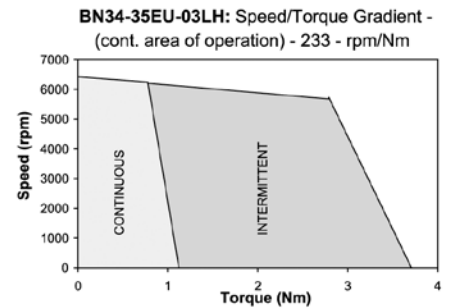
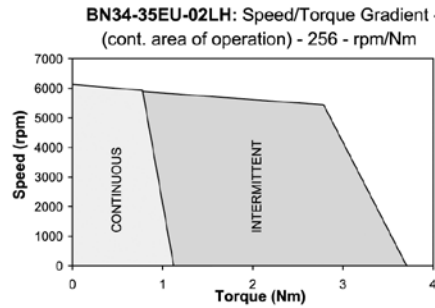
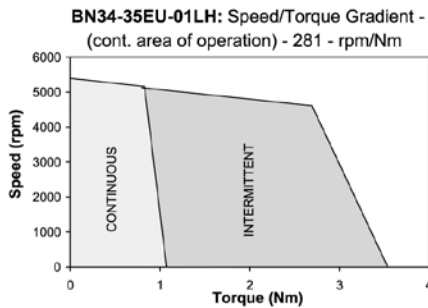
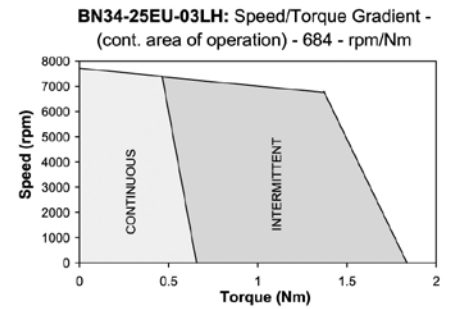
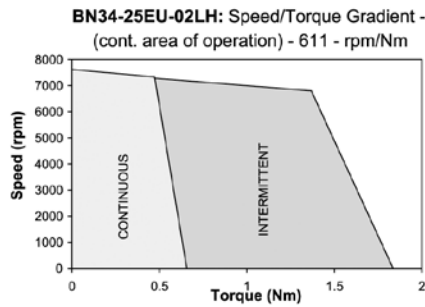
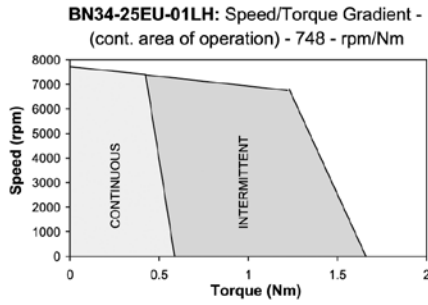

Note: Intermittent operation is based on a 20% duty cycle of one minute on, four minutes off. Please contact the factory regarding the duty cycle of your application.

BN34 IP65 Specifications

Inside Rotor
Brushless Motors

BN34 IP65 SPECIFICATIONS - Continuous Stall Torque 83 - 309 oz-in (0.587 - 2.19 Nm) Peak Torque 326 - 1445 oz-in (2.31 - 10.21 Nm)

Part Number*		BN34-25IP - <input type="checkbox"/> <input type="checkbox"/> <input type="checkbox"/> <input type="checkbox"/> <input type="checkbox"/>			BN34-35IP - <input type="checkbox"/> <input type="checkbox"/> <input type="checkbox"/> <input type="checkbox"/> <input type="checkbox"/>			BN34-45IP - <input type="checkbox"/> <input type="checkbox"/> <input type="checkbox"/> <input type="checkbox"/> <input type="checkbox"/>			BN34-55IP - <input type="checkbox"/> <input type="checkbox"/> <input type="checkbox"/> <input type="checkbox"/> <input type="checkbox"/>		
Winding Code**		01	02	03	01	02	03	01	02	03	01	02	03
L = Length	inches	2.5			3.5			4.5			5.5		
	millimeters	63.5			88.9			114.3			139.7		
Terminal Voltage	volts DC	24	50	100	24	50	100	24	50	100	24	50	100
Peak Torque	oz-in	310	310	310	657	643	657	1006	1006	1006	1375	1375	1375
	Nm	2.19	2.19	2.19	4.64	4.5405	4.64	7.11	7.11	7.11	9.71	9.71	9.71
Continuous Stall Torque	oz-in	88	93	90	140	162	172	210	220	236	249	288	299
	Nm	0.62	0.66	0.64	0.99	1.144	1.21	1.49	1.55	1.67	1.76	2.03	2.11
Rated Speed	RPM	8130	7500	7280	6010	6400	6380	3800	5170	5270	2750	4350	4360
	rad/sec	851	785	762	629	670	667	397	541	552	288	455	456
Rated Torque	oz-in	60	64	62	93	106	110	172	148	170	214	208	214
	Nm	0.4237	0.45	0.44	0.6567	0.749	0.78	1.24	1.05	1.2005	1.51	1.49	1.51
Rated Current	Amps	16.98	8	3.77	18.74	11	5.8	23.1	12.6	7	21.16	14.85	7.63
Rated Power	watts	361	355	334	417	502	519	483	567	612	435	669	690
Torque Sensitivity	oz-in/amp	3.78	8.5	17.48	5.06	9.92	20.26	7.76	12.42	26.39	10.5	14.7	29.39
	Nm/amp	0.027	0.06	0.123	0.036	0.0701	0.142	0.055	0.088	0.186	0.074	0.104	0.208
Back EMF	volts/KRPM	2.79	6.29	12.92	3.74	7.34	14.98	5.74	9.18	19.51	7.76	10.87	21.73
	volts/rad/sec	0.027	0.06	0.123	0.036	0.07	0.143	0.055	0.088	0.186	0.074	0.104	0.208
Terminal Resistance	ohms	0.079	0.253	1.12	0.05	0.147	0.548	0.068	0.141	0.557	0.088	0.131	0.487
Terminal Inductance	mH	0.12	0.62	2.62	0.1	0.43	1.72	0.17	0.43	1.94	0.23	0.44	1.78
Motor Constant	oz-in/sq.rt.watt	13.44	16.11	16.51	22.63	25.87	27.37	29.75	33.06	35.36	35.4	40.61	42.11
	Nm/sq.rt.watt	0.11	0.11	0.12	0.16	0.183	0.19	0.22	0.23	0.25	0.25	0.29	0.3
Rotor Inertia	oz-in-sec ² x10 ⁻³	7.2	7.2	7.2	14.1	12	14	21	21	21	28	28	28
	g-cm ²	510	510	510	1000	846.8	1000	1500	1500	1500	2000	2000	2000
Weight	oz	36	37	36	62	62	62	87	89	89	114	116	116
	g	1020	1030	1030	1750	1760.8	1770	2480	2520	2530	3230	3300	3.3
# of Poles		8	8	8	8	8	8	8	8	8	8	8	8
Timing		120°	120°	120°	120°	120°	120°	120°	120°	120°	120°	120°	120°
Mech. Time Constant	ms	3.87	3.58	3.75	3.96	2.5	2.7	3.38	2.75	2.41	3.2	2.43	2.26
Electrical Time Constant	ms	2.27	2.45	2.34	2.14	2.9	3.15	2.48	3.04	3.48	2.58	3.4	3.66
Thermal Resistivity	deg. C/watt	2.25	2.39	2.41	1.87	1.84	1.84	1.51	1.63	1.62	1.45	1.43	1.43
Speed/Torque Gradient	rpm/oz-in	5.3	4.3	4.3	2.8	2.8	1.8	1.1	1	1	0.8	0.7	0.6

Notes:

- Motor mounted to a 10 x 10 x 1/4 inches aluminum plate, still air.
- Maximum winding temperature of 155°C.
- Typical electrical specifications at 25°C.
- Motor Terminal Voltages are representative only; motors may be operated at voltages other than those listed in the table. For assistance please contact our applications engineer.
- Calculated (theoretical) speed/torque gradient.
- For MS (military style) connector, please specify connector housing and terminal.
- Data for informational purposes only. Should not be considered a binding performance agreement. For specific applications, please contact the factory.

*Many other custom mechanical options are available – consult factory.
**Many other winding options are available – consult factory.

Select your options below and place their code in its corresponding block as shown on page 5.

- | | | |
|----------------------|---------------------------|------------------------|
| T TERMINATION | F FEEDBACK OPTIONS | O OTHER OPTIONS |
| L – Leads (std) | H – Hall Effect (std) | D – Drive |
| C – Connector | R – Resolver | E – Encoder |
| M – MS connector | S – Sensorless | G – Gearhead |

BN34 IP65 Typical Outline

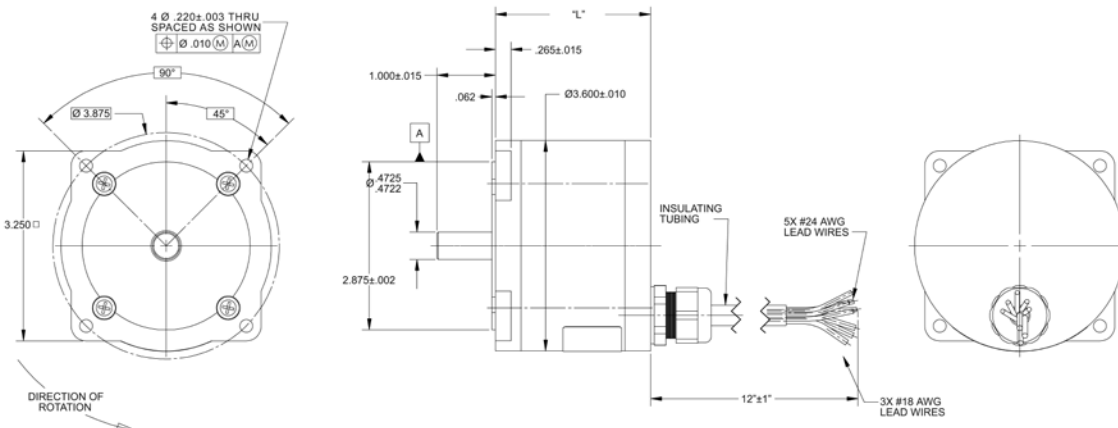

Termination Table

PIN COLOR	CONNECTION
YELLOW	V _{CC}
GRAY	GROUND
RED	A COIL
BLACK	B COIL
GREEN	C COIL
BLUE	S2 OUT
BROWN	S1 OUT
ORANGE	S3 OUT

Dimensions are in inches

BN34 IP65 Performance Curves

BN34 IP65 Performance Curves

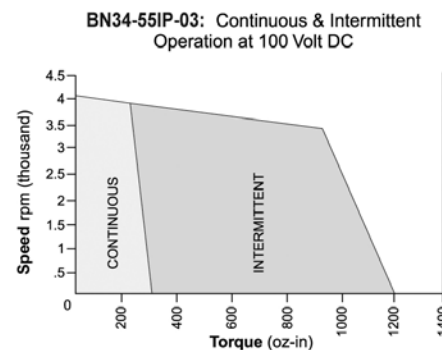
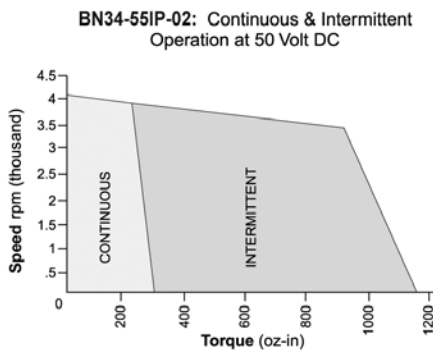
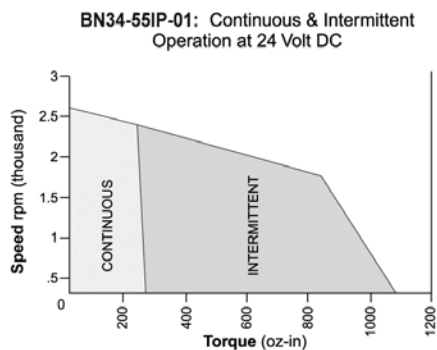
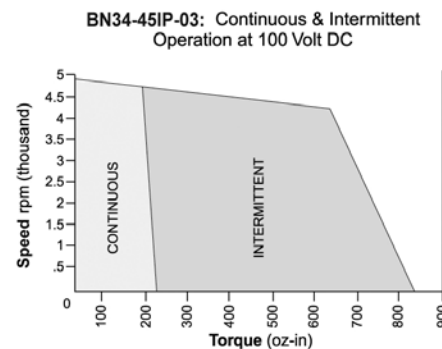
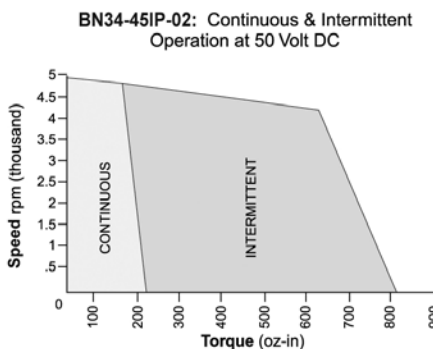
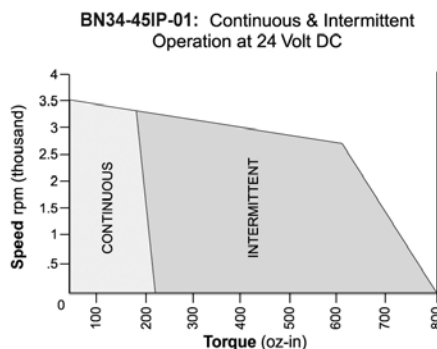
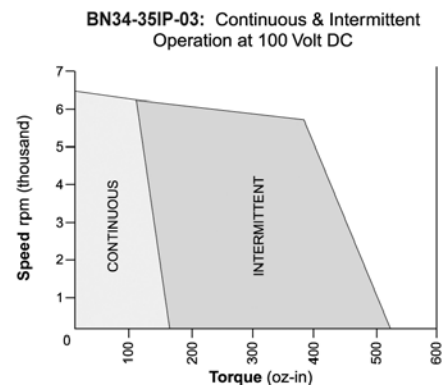
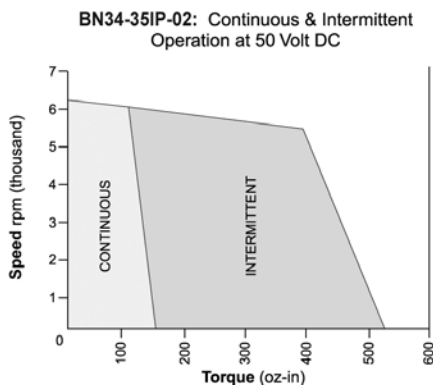
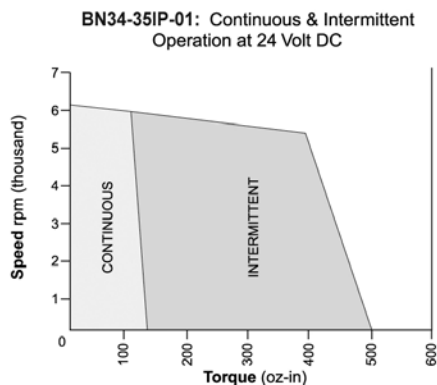
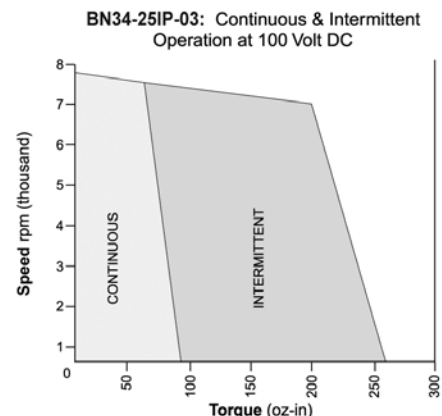
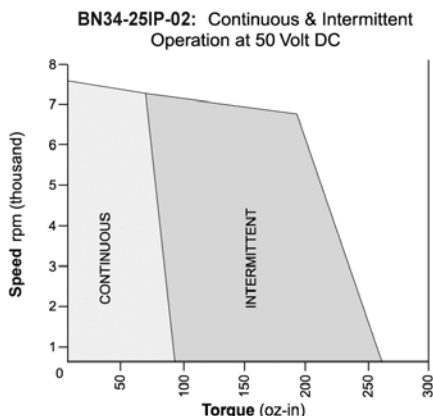
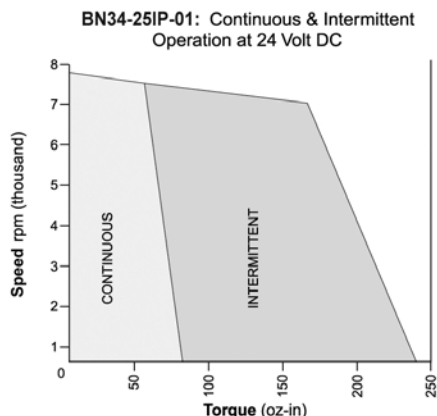

Note: Intermittent operation is based on a 20% duty cycle of one minute on, four minutes off. Please contact the factory regarding the duty cycle of your application.

BN42 Specifications

Inside Rotor
Brushless Motors

BN42 SPECIFICATIONS - *Continuous Stall Torque 144 - 519 oz-in (1.02 - 3.67 Nm)* *Peak Torque 609 - 2560 oz-in (4.30 - 18.1 Nm)*

Part Number*		BN42-23AF- <input type="checkbox"/> <input type="checkbox"/> <input type="checkbox"/> <input type="checkbox"/>			BN42-33AF- <input type="checkbox"/> <input type="checkbox"/> <input type="checkbox"/> <input type="checkbox"/>			BN42-43AF- <input type="checkbox"/> <input type="checkbox"/> <input type="checkbox"/> <input type="checkbox"/>			BN42-53AF- <input type="checkbox"/> <input type="checkbox"/> <input type="checkbox"/> <input type="checkbox"/>		
Winding Code**		01	02	03	01	02	03	01	02	03	01	02	03
L = Length	inches	2.30			3.30			4.30			5.30		
	millimeters	58.4			83.8			109.2			134.6		
Terminal Voltage	volts DC	24.0	50.0	100.0	24.0	50.0	100.0	24.0	50.0	100.0	24.0	50.0	100.0
Peak Torque	oz-in	609.0	609.0	609.0	1248.0	1248.0	1248.0	1906.0	1906.0	1906.0	2560.0	2560.0	2560.0
	Nm	4.3005	4.3005	4.3005	8.8128	8.8128	8.8128	13.4592	13.4592	13.4592	18.0774	18.0774	18.0774
Continuous Stall Torque	oz-in	144.0	156.0	155.0	266.0	281.0	287.0	387.0	398.0	407.0	496.0	510.0	519.0
	Nm	1.0169	1.1016	1.0945	1.8784	1.9843	2.0267	2.7328	2.8105	2.8740	3.5025	3.6014	3.6649
Rated Speed	RPM	6050.0	5950.0	6140.0	3710.0	4710.0	4710.0	2380.0	3840.0	3840.0	1740.0	2820.0	2820.0
	rad/sec	634	623	643	389	493	493	249	402	402	182	295	295
Rated Torque	oz-in	102.0	113.0	110.0	213.0	198.0	200.0	340.0	290.0	296.0	451.0	413.0	419.0
	Nm	0.7203	0.7979	0.7768	1.5041	1.3982	1.4123	2.4009	2.0478	2.0902	3.1847	2.9164	2.9588
Rated Current	Amps	22.60	11.70	5.90	28.90	16.20	8.20	29.70	19.20	9.80	29.20	20.20	10.20
Rated Power	watts	456.0	497.0	499.0	584.0	690.0	697.0	598.0	824.0	841.0	580.0	861.0	874.0
Torque Sensitivity	oz-in/amp	5.20	11.00	21.40	8.41	14.00	28.00	12.90	17.20	34.30	17.40	23.10	46.30
	Nm/amp	0.0367	0.0777	0.1511	0.0594	0.0989	0.1977	0.0911	0.1215	0.2422	0.1229	0.1631	0.3269
Back EMF	volts/KRPM	3.80	8.20	15.80	6.22	10.40	20.70	9.52	12.70	25.40	12.80	17.10	34.20
	volts/rad/sec	0.0367	0.0777	0.1511	0.0594	0.0989	0.1977	0.0911	0.1215	0.2422	0.1229	0.1631	0.3269
Terminal Resistance	ohms	0.040	0.154	0.584	0.039	0.095	0.364	0.052	0.084	0.320	0.065	0.106	0.408
Terminal Inductance	mH	0.090	0.408	1.540	0.115	0.318	1.270	0.178	0.316	1.260	0.241	0.428	1.710
Motor Constant	oz-in/sq.rt.watt	26.00	28.03	28.00	42.59	45.42	46.41	56.57	59.35	60.63	68.25	70.95	72.49
	Nm/sq.rt.watt	0.18360	0.19794	0.19775	0.30072	0.32075	0.32772	0.39947	0.41907	0.42817	0.48194	0.50102	0.51186
Rotor Inertia	oz-in-sec ² x10 ⁻³	18.00	18.00	18.00	35.00	35.00	35.00	52.00	52.00	52.00	70.00	70.00	70.00
	g-cm ²	1270.3	1270.3	1270.3	2470.0	2470.0	2470.0	3669.6	3669.6	3669.6	4939.9	4939.9	4939.9
Weight	oz	65.0	65.0	65.0	104.0	104.0	104.0	143.0	143.0	143.0	182.0	182.0	182.0
	g	1846.0	1846.0	1846.0	2953.6	2953.6	2953.6	4061.2	4061.2	4061.2	5168.8	5168.8	5168.8
# of Poles		8.0	8.0	8.0	8.0	8.0	8.0	8.0	8.0	8.0	8.0	8.0	8.0
Timing		120°	120°	120°	120°	120°	120°	120°	120°	120°	120°	120°	120°
Mech. Time Constant	ms	3.8	3.2	3.2	2.7	2.4	2.3	2.3	2.1	2.0	2.1	2.0	1.9
Electrical Time Constant	ms	2.25	2.65	2.64	2.95	3.35	3.49	3.42	3.76	3.94	3.71	4.04	4.19
Thermal Resistivity	deg. C/watt	1.2	1.2	1.2	1.0	0.9	0.9	0.9	0.8	0.8	0.9	0.7	0.7
Speed/Torque Gradient	rpm/oz-in	2.0	1.7	1.7	0.7	0.7	0.6	0.4	0.4	0.4	0.3	0.3	0.3

Notes:

- Motor mounted to a 10 x 10 x 1/4 inches aluminum plate, still air.
- Maximum winding temperature of 155°C.
- Typical electrical specifications at 25°C.
- Motor Terminal Voltages are representative only; motors may be operated at voltages other than those listed in the table. For assistance please contact our applications engineer.
- For MS (military style) connector, please specify connector housing and terminal.
- Data for informational purposes only. Should not be considered a binding performance agreement. For specific applications, please contact the factory.

*Many other custom mechanical options are available – consult factory.

**Many other winding options are available – consult factory.

Select your options below and place their code in its corresponding block as shown on page 5.

- | | | |
|--|---|--|
| <input checked="" type="checkbox"/> TERMINATION | <input checked="" type="checkbox"/> FEEDBACK OPTIONS | <input checked="" type="checkbox"/> OTHER OPTIONS |
| L – Leads (std) | H – Hall Effect (std) | D – Drive |
| C – Connector | R – Resolver | E – Encoder |
| M – MS connector | S – Sensorless | G – Gearhead |

BN42 Typical Outline

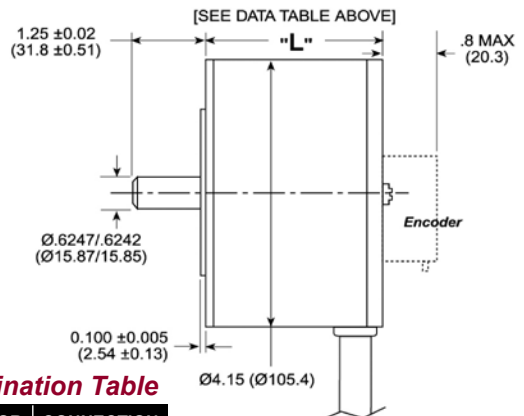
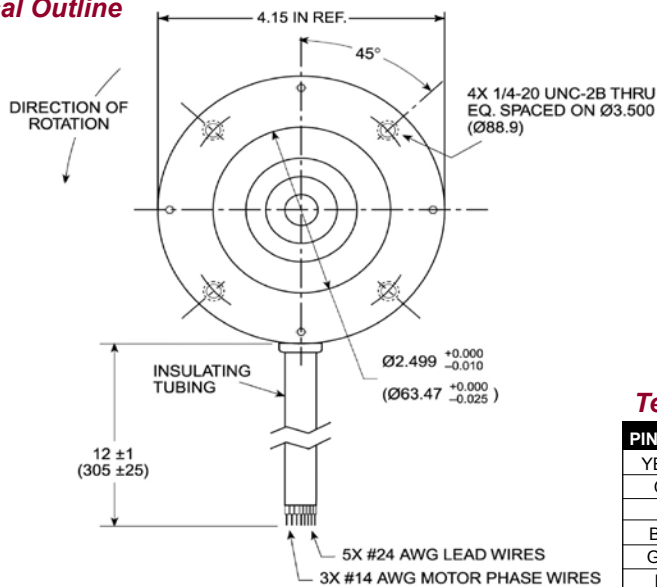

Termination Table

PIN COLOR	CONNECTION
YELLOW	V _{CC}
GRAY	GROUND
RED	A COIL
BLACK	B COIL
GREEN	C COIL
BLUE	S2 OUT
BROWN	S1 OUT
ORANGE	S3 OUT

Dimensions are in inches (millimeters)

Note: An optional 4.15 (105.4) square front end cap is available.

BN42 Performance Curves

BN42 Performance Curves

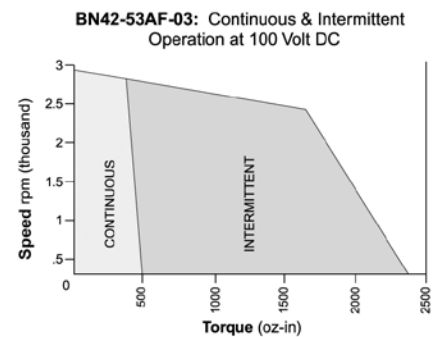
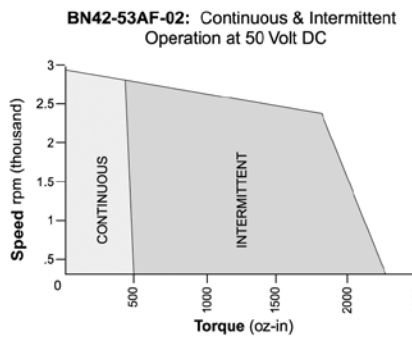
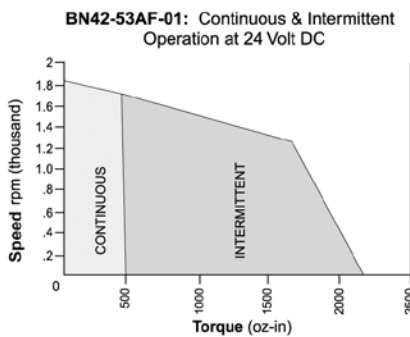
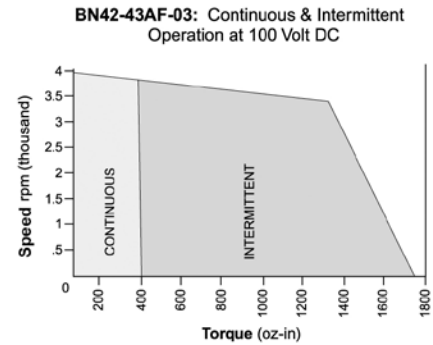
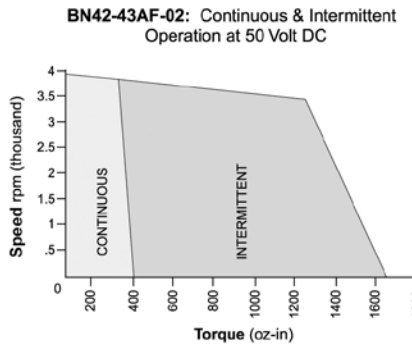
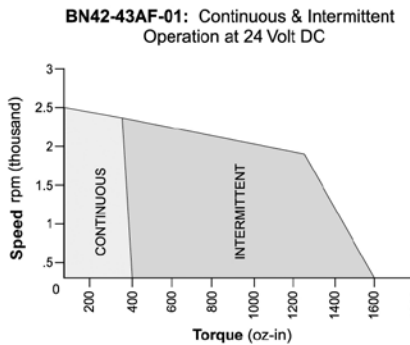
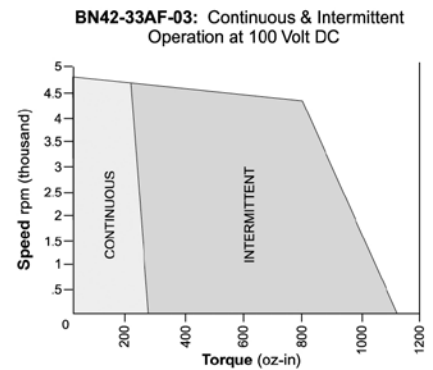
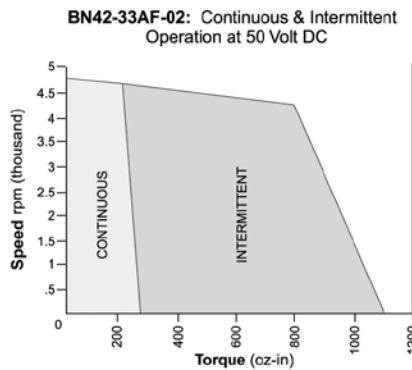
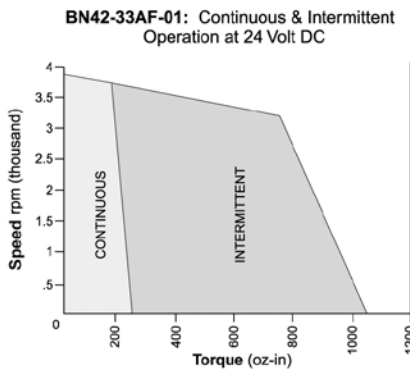
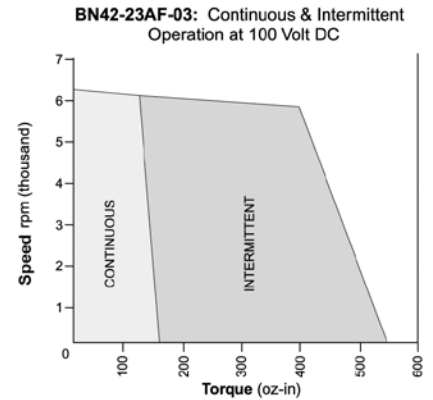
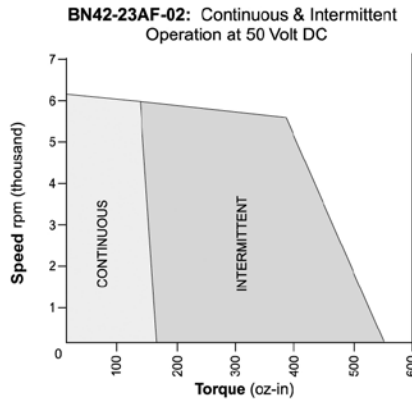
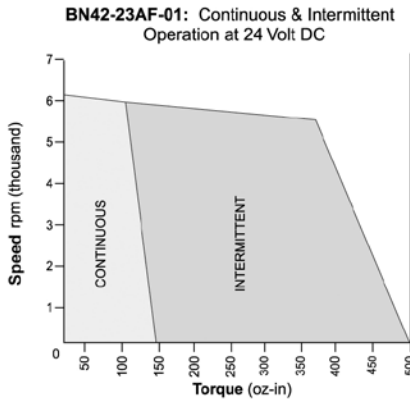

Note: Intermittent operation is based on a 20% duty cycle of one minute on, four minutes off.
Please contact the factory regarding the duty cycle of your application.

BN42 EU Specifications

BN42 EU SPECIFICATIONS -

Continuous Stall Torque 144 - 519 oz-in (1.02 - 3.67 Nm)
Peak Torque 609 - 2560 oz-in (4.30 - 18.1 Nm)

Inside Rotor
Brushless Motors

Part Number*		BN42-23EU- <input type="checkbox"/> <input type="checkbox"/> <input type="checkbox"/> <input type="checkbox"/>			BN42-33EU- <input type="checkbox"/> <input type="checkbox"/> <input type="checkbox"/> <input type="checkbox"/>			BN42-43EU- <input type="checkbox"/> <input type="checkbox"/> <input type="checkbox"/> <input type="checkbox"/>			BN42-53EU- <input type="checkbox"/> <input type="checkbox"/> <input type="checkbox"/> <input type="checkbox"/>		
Winding Code**		01	02	03	01	02	03	01	02	03	01	02	03
L = Length	inches	2.30			3.30			4.30			5.30		
	millimeters	58.5			83.9			109.3			134.7		
Terminal Voltage	volts DC	24	50	100	24	50	100	24	50	100	24	50	100
Peak Torque	oz-in	609	609	609	1248	1248	1248	1906	1906	1906	2560	2560	2560
	Nm	4.30	4.30	4.30	8.82	8.82	8.82	13.5	13.5	13.5	18.1	18.1	18.1
Continuous Stall Torque	oz-in	144	156	155	266	281	287	387	398	407	496	510	519
	Nm	1.02	1.11	1.10	1.88	1.99	2.03	2.74	2.81	2.88	3.51	3.61	3.67
Rated Speed	RPM	6050	5950	6140	3710	4710	4710	2380	3840	3840	1740	2820	2820
	rad/sec	634	623	643	389	494	494	250	403	403	183	296	296
Rated Torque	oz-in	102	113	110	213	198	200	340	290	296	451	413	419
	Nm	0.721	0.798	0.777	1.51	1.40	1.42	2.41	2.05	2.09	3.19	2.92	2.96
Rated Current	Amps	22.6	11.7	5.9	28.9	16.2	8.2	29.7	19.2	9.8	29.2	20.2	10.2
Rated Power	watts	456	497	499	584	690	697	598	824	841	580	861	874
Torque Sensitivity	oz-in/amp	5.20	11.0	21.4	8.41	14.0	28.0	12.9	17.2	34.3	17.4	23.1	46.3
	Nm/amp	0.0363	0.0783	0.151	0.0594	0.0992	0.198	0.0909	0.122	0.243	0.123	0.164	0.327
Back EMF	volts/KRPM	3.80	8.20	15.8	6.22	10.4	20.7	9.52	12.7	25.4	12.8	17.1	34.2
	volts/rad/sec	0.0363	0.0783	0.151	0.0594	0.0992	0.198	0.0909	0.122	0.243	0.123	0.164	0.327
Terminal Resistance	ohms	0.040	0.154	0.584	0.039	0.095	0.364	0.052	0.084	0.320	0.065	0.106	0.408
Terminal Inductance	mH	0.090	0.408	1.54	0.115	0.318	1.27	0.178	0.316	1.26	0.241	0.428	1.71
Motor Constant	oz-in/sq.rt.watt	27.8	28.6	28.2	45.7	46.8	46.8	59.5	61.2	61.1	71.0	73.0	72.9
	Nm/sq.rt.watt	0.197	0.202	0.199	0.323	0.331	0.331	0.421	0.433	0.432	0.502	0.516	0.515
Rotor Inertia	oz-in-sec ²	0.018	0.018	0.018	0.035	0.035	0.035	0.052	0.052	0.052	0.070	0.070	0.070
	g-cm ²	1271	1271	1271	2472	2472	2472	3672	3672	3672	4943	4943	4943
Weight	oz	65	65	65	104	104	104	143	143	143	182	182	182
	g	1843	1843	1843	2949	2949	2949	4054	4054	4054	5160	5160	5160

Notes:

- Motor mounted to a 10 x 10 x 1/4 inches aluminum plate, still air.
- Maximum winding temperature of 155°C.
- Typical electrical specifications at 25°C.
- Motor Terminal Voltages are representative only; motors may be operated at voltages other than those listed in the table. For assistance please contact our applications engineer.
- For MS (military style) connector, please specify connector housing and terminal.
- Data for informational purposes only. Should not be considered a binding performance agreement. For specific applications, please contact the factory.

*Many other custom mechanical options are available – consult factory.

**Many other winding options are available – consult factory.

Select your options below and place their code in its corresponding block as shown on page 5.

- | | | |
|---|--|---|
| <input type="checkbox"/> TERMINATION | <input type="checkbox"/> FEEDBACK OPTIONS | <input type="checkbox"/> OTHER OPTIONS |
| L – Leads (std) | H – Hall Effect (std) | D – Drive |
| C – Connector | R – Resolver | E – Encoder |
| M – MS connector | S – Sensorless | G – Gearhead |

BN42 EU Typical Outline

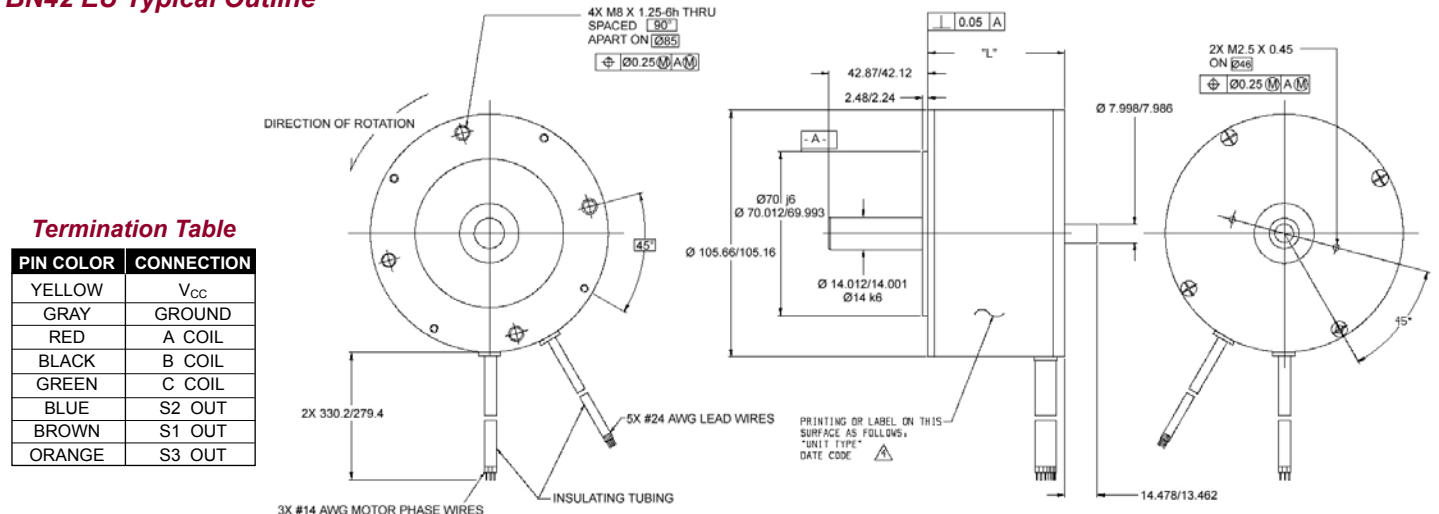

Dimensions are in inches

BN42 EU Performance Curves

BN42 EU Performance Curves

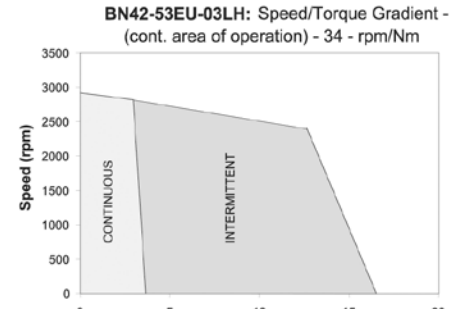
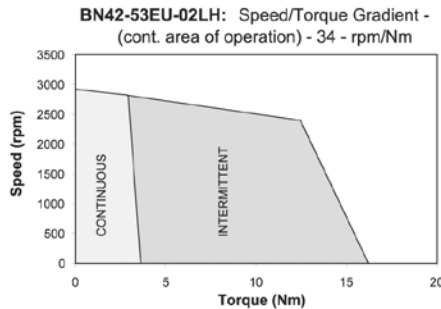
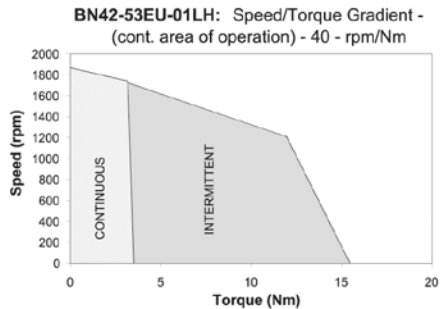
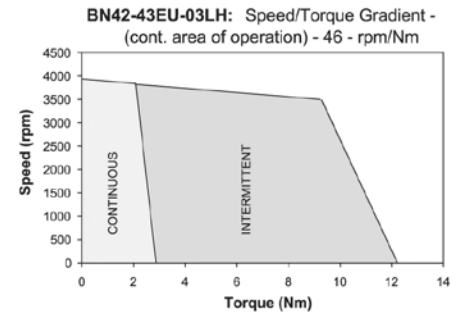
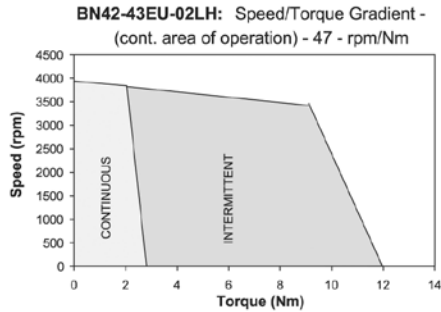
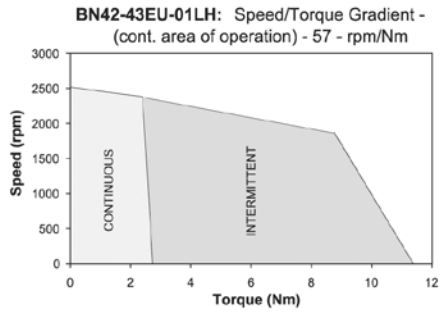
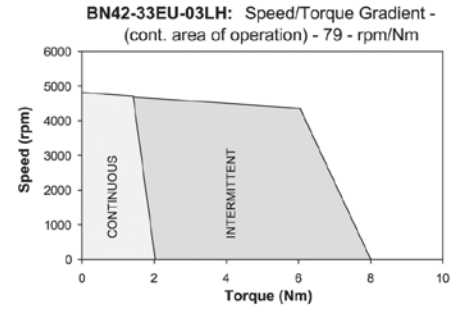
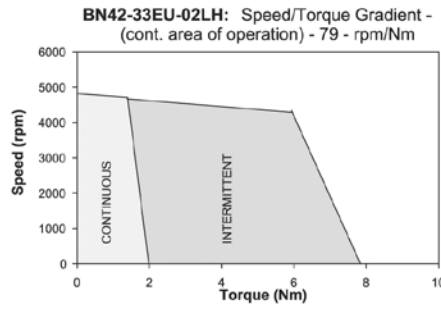
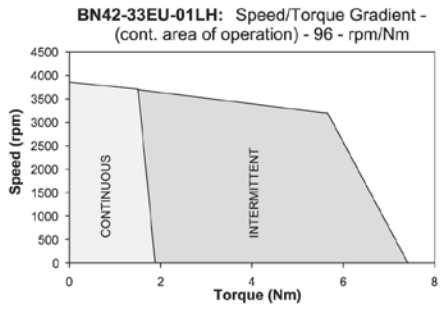
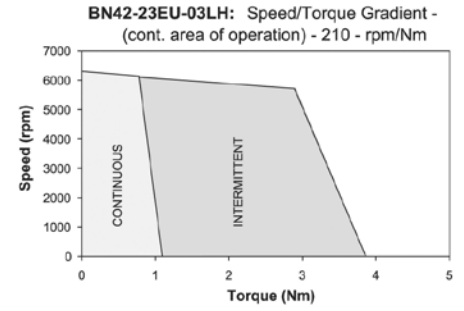
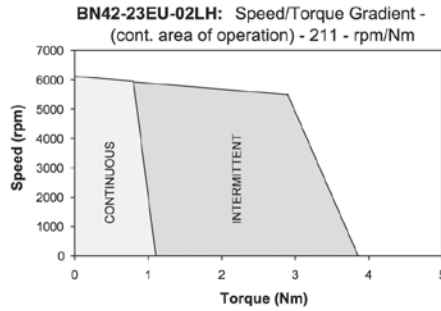
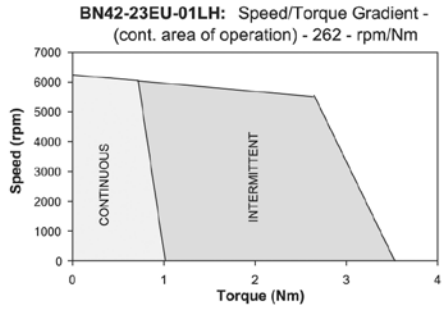

Note: Intermittent operation is based on a 20% duty cycle of one minute on, four minutes off.
Please contact the factory regarding the duty cycle of your application.

BN42 IP65 Specifications

Inside Rotor
Brushless Motors

BN42 IP65 SPECIFICATIONS - Continuous Stall Torque 144 - 519 oz-in (1.02 - 3.67 Nm) Peak Torque 609 - 2560 oz-in (4.30 - 18.1 Nm)

Part Number*		BN42-23IP - <input type="checkbox"/> <input type="checkbox"/> <input type="checkbox"/> <input type="checkbox"/> <input type="checkbox"/> <input type="checkbox"/>			BN42-33IP - <input type="checkbox"/> <input type="checkbox"/> <input type="checkbox"/> <input type="checkbox"/> <input type="checkbox"/> <input type="checkbox"/>			BN42-43IP - <input type="checkbox"/> <input type="checkbox"/> <input type="checkbox"/> <input type="checkbox"/> <input type="checkbox"/> <input type="checkbox"/>			BN42-53IP - <input type="checkbox"/> <input type="checkbox"/> <input type="checkbox"/> <input type="checkbox"/> <input type="checkbox"/> <input type="checkbox"/>		
Winding Code**		01	02	03	01	02	03	01	02	03	01	02	03
L = Length	inches	2.30			3.30			4.30			5.30		
	millimeters	58.4			83.8			109.2			134.6		
Terminal Voltage	volts DC	24.0	50.0	100.0	24.0	50.0	100.0	24.0	50.0	100.0	24.0	50.0	100.0
Peak Torque	oz-in	609.0	609.0	609.0	1248.0	1248.0	1248.0	1906.0	1906.0	1906.0	2560.0	2560.0	2560.0
	Nm	4.3005	4.3005	4.3005	8.8128	8.8128	8.8128	13.4592	13.4592	13.4592	18.0774	18.0774	18.0774
Continuous Stall Torque	oz-in	144.0	156.0	155.0	266.0	281.0	287.0	387.0	398.0	407.0	496.0	510.0	519.0
	Nm	1.0169	1.1016	1.0945	1.8784	1.9843	2.0267	2.7328	2.8105	2.8740	3.5025	3.6014	3.6649
Rated Speed	RPM	6050.0	5950.0	6140.0	3710.0	4710.0	4710.0	2380.0	3840.0	3840.0	1740.0	2820.0	2820.0
	rad/sec	634	623	643	389	493	493	249	402	402	182	295	295
Rated Torque	oz-in	102.0	113.0	110.0	213.0	198.0	200.0	340.0	290.0	296.0	451.0	413.0	419.0
	Nm	0.7203	0.7979	0.7768	1.5041	1.3982	1.4123	2.4009	2.0478	2.0902	3.1847	2.9164	2.9588
Rated Current	Amps	22.60	11.70	5.90	28.90	16.20	8.20	29.70	19.20	9.80	29.20	20.20	10.20
Rated Power	watts	456.0	497.0	499.0	584.0	690.0	697.0	598.0	824.0	841.0	580.0	861.0	874.0
Torque Sensitivity	oz-in/amp	5.20	11.00	21.40	8.41	14.00	28.00	12.90	17.20	34.30	17.40	23.10	46.30
	Nm/amp	0.0367	0.0777	0.1511	0.0594	0.0989	0.1977	0.0911	0.1215	0.2422	0.1229	0.1631	0.3269
Back EMF	volts/KRPM	3.80	8.20	15.80	6.22	10.40	20.70	9.52	12.70	25.40	12.80	17.10	34.20
	volts/rad/sec	0.0367	0.0777	0.1511	0.0594	0.0989	0.1977	0.0911	0.1215	0.2422	0.1229	0.1631	0.3269
Terminal Resistance	ohms	0.040	0.154	0.584	0.039	0.095	0.364	0.052	0.084	0.320	0.065	0.106	0.408
Terminal Inductance	mH	0.090	0.408	1.540	0.115	0.318	1.270	0.178	0.316	1.260	0.241	0.428	1.710
Motor Constant	oz-in/sq.rt.watt	26.00	28.03	28.00	42.59	45.42	46.41	56.57	59.35	60.63	68.25	70.95	72.49
	Nm/sq.rt.watt	0.18360	0.19794	0.19775	0.30072	0.32075	0.32772	0.39947	0.41907	0.42817	0.48194	0.50102	0.51186
Rotor Inertia	oz-in-sec ² x10 ⁻³	18.00	18.00	18.00	35.00	35.00	35.00	52.00	52.00	52.00	70.00	70.00	70.00
	g-cm ²	1270.3	1270.3	1270.3	2470.0	2470.0	2470.0	3669.6	3669.6	3669.6	4939.9	4939.9	4939.9
Weight	oz	65.0	65.0	65.0	104.0	104.0	104.0	143.0	143.0	143.0	182.0	182.0	182.0
	g	1846.0	1846.0	1846.0	2953.6	2953.6	2953.6	4061.2	4061.2	4061.2	5168.8	5168.8	5168.8
# of Poles		8.0	8.0	8.0	8.0	8.0	8.0	8.0	8.0	8.0	8.0	8.0	8.0
Timing		120°	120°	120°	120°	120°	120°	120°	120°	120°	120°	120°	120°
Mech. Time Constant	ms	3.8	3.2	3.2	2.7	2.4	2.3	2.3	2.1	2.0	2.1	2.0	1.9
Electrical Time Constant	ms	2.25	2.65	2.64	2.95	3.35	3.49	3.42	3.76	3.94	3.71	4.04	4.19
Thermal Resistivity	deg. C/watt	1.2	1.2	1.2	1.0	0.9	0.9	0.9	0.8	0.8	0.9	0.7	0.7
Speed/Torque Gradient	rpm/oz-in	2.0	1.7	1.7	0.7	0.7	0.6	0.4	0.4	0.4	0.3	0.3	0.3

Notes:

- Motor mounted to a 10 x 10 x 1/4 inches aluminum plate, still air.
- Maximum winding temperature of 155°C.
- Typical electrical specifications at 25°C.
- Motor Terminal Voltages are representative only; motors may be operated at voltages other than those listed in the table. For assistance please contact our applications engineer.
- Calculated (theoretical) speed/torque gradient.
- For MS (military style) connector, please specify connector housing and terminal.
- Data for informational purposes only. Should not be considered a binding performance agreement. For specific applications, please contact the factory.

*Many other custom mechanical options are available – consult factory.
**Many other winding options are available – consult factory.

Select your options below and place their code in its corresponding block as shown on page 5.

- | | | |
|--|---|--|
| <input checked="" type="checkbox"/> TERMINATION | <input checked="" type="checkbox"/> FEEDBACK OPTIONS | <input checked="" type="checkbox"/> OTHER OPTIONS |
| L – Leads (std) | H – Hall Effect (std) | D – Drive |
| C – Connector | R – Resolver | E – Encoder |
| M – MS connector | S – Sensorless | G – Gearhead |

BN42 IP65 Typical Outline

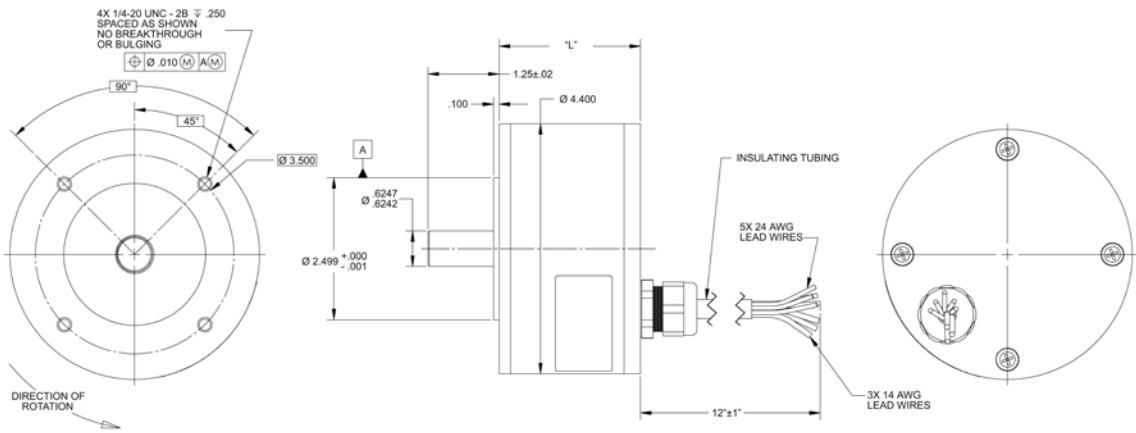

Termination Table

PIN COLOR	CONNECTION
YELLOW	VCC
GRAY	GROUND
RED	A COIL
BLACK	B COIL
GREEN	C COIL
BLUE	S2 OUT
BROWN	S1 OUT
ORANGE	S3 OUT

Dimensions are in inches

Note: An optional 4.15 (105.4) square front end cap is available.

BN42 IP65 Performance Curves

BN42 IP65 Performance Curves

BN42-23IP-01: Continuous & Intermittent Operation at 24 Volt DC

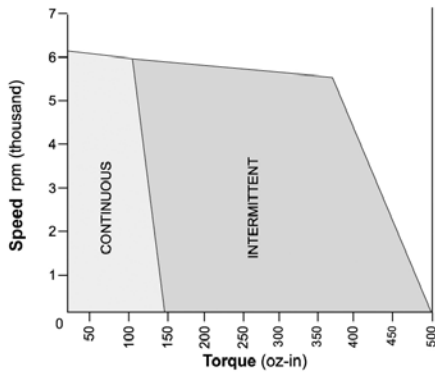

BN42-23IP-02: Continuous & Intermittent Operation at 50 Volt DC

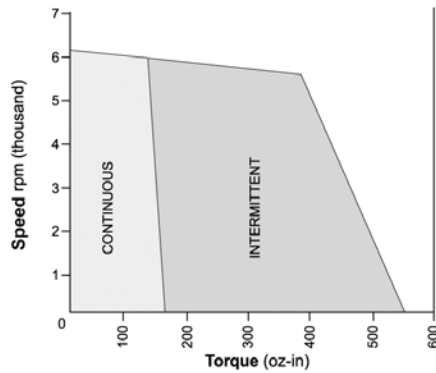

BN42-23IP-03: Continuous & Intermittent Operation at 100 Volt DC

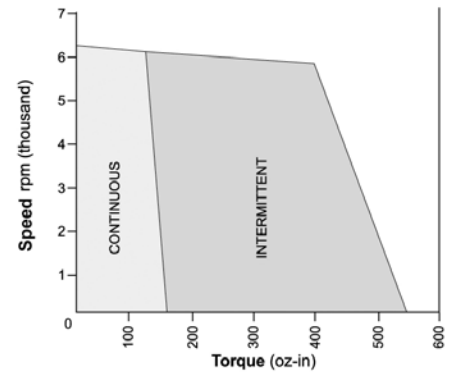

BN42-33IP-01: Continuous & Intermittent Operation at 24 Volt DC

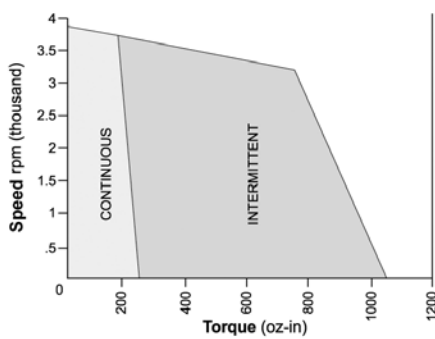

BN42-33IP-02: Continuous & Intermittent Operation at 50 Volt DC

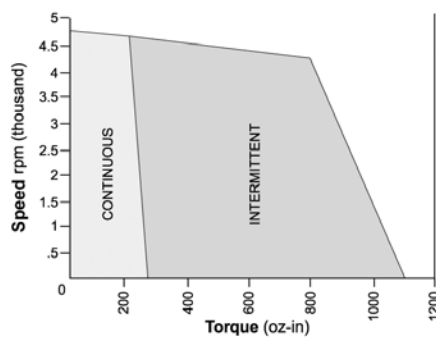

BN42-33IP-03: Continuous & Intermittent Operation at 100 Volt DC

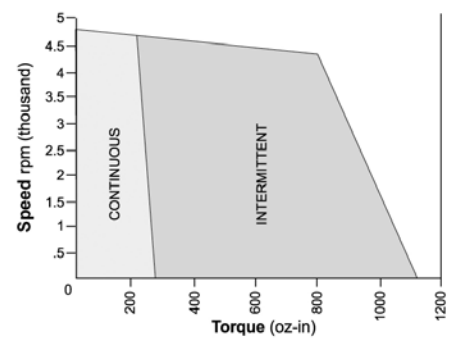

BN42-43IP-01: Continuous & Intermittent Operation at 24 Volt DC

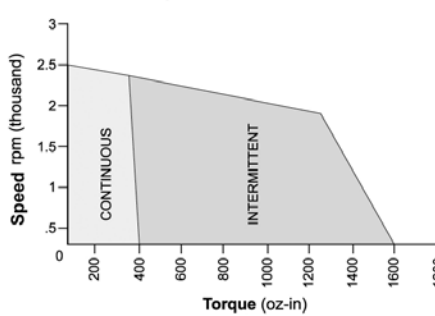

BN42-43IP-02: Continuous & Intermittent Operation at 50 Volt DC

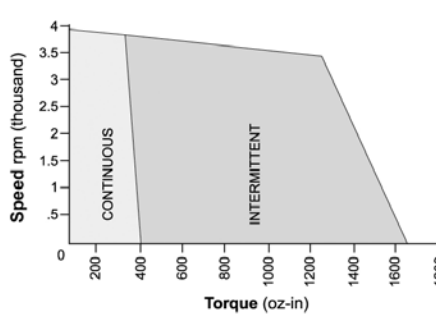

BN42-43IP-03: Continuous & Intermittent Operation at 100 Volt DC

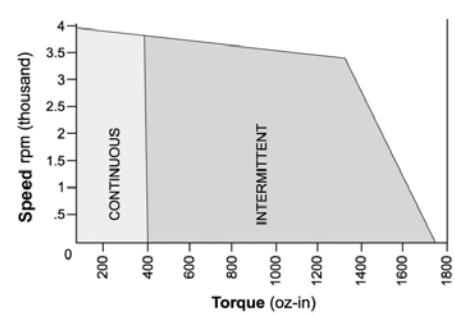

BN42-53IP-01: Continuous & Intermittent Operation at 24 Volt DC

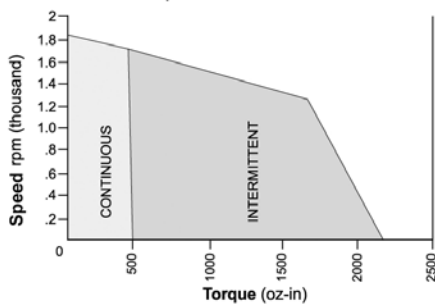

BN42-53IP-02: Continuous & Intermittent Operation at 50 Volt DC

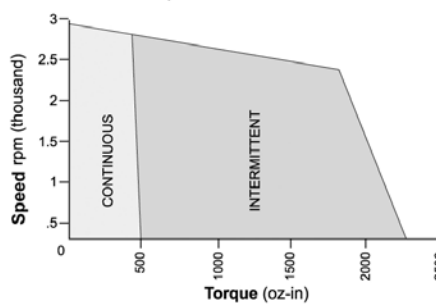

BN42-53IP-03: Continuous & Intermittent Operation at 100 Volt DC

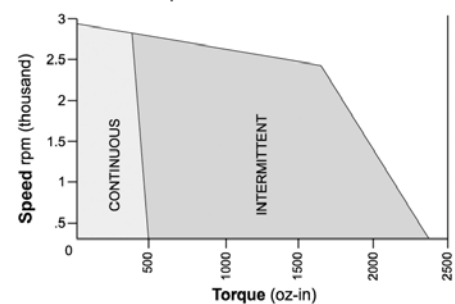

Note: Intermittent operation is based on a 20% duty cycle of one minute on, four minutes off. Please contact the factory regarding the duty cycle of your application.