



We make sure
NOTHING
gets out!

HERMETIX[™]

ZERO-Stem-Leak Valve Series

PATENT PENDING

**ZERO
STEM LEAK**
ISO 15848-1 Approved

4-Year Guarantee!

 **HABONIM**
Industrial Valves & Actuators

DEDICATED TO INNOVATION



HERMETIX™

ZERO-Stem-Leak Valve Series

HermetiX™ Valves STOP Fugitive Emissions For a Greener World

As world focus turns to preserving our environment, Habonim introduces its new ZERO-Stem-Leak* HermetiX™ valve series. Based on the HermetiX™ stem seal technology, the new Habonim valves meet strict ISO 15848-1** standards for fugitive emissions.

* ZERO-Stem-Leak

The maximum allowable leak rate for a 1/2" bore HermetiX™ valve meeting ISO 15848 standards is 10E-6 mg/s/m (at ambient temperature and pressure). If the valve were to leak at its maximum permitted rates, total leakage would be 5.35 cm³ of helium in a year!

** What is ISO 15848-1?

15848-1 specifies procedures for testing external leakage of valve stem seals (or shaft) and body joints of isolating and control valves used in volatile air pollutants and hazardous fluids applications. The standard defines a minimum of CO5 (5k cycles) performance at extreme temperature changes.



What is HermetiX™?

Named after its distinctive X-shaped design, the patent-pending HermetiX™ seal is designed to eliminate stem leakage. Even as fluid pressure or side load increases, the HermetiX™ seal dynamically adjusts to prevent fugitive emission (see picture).

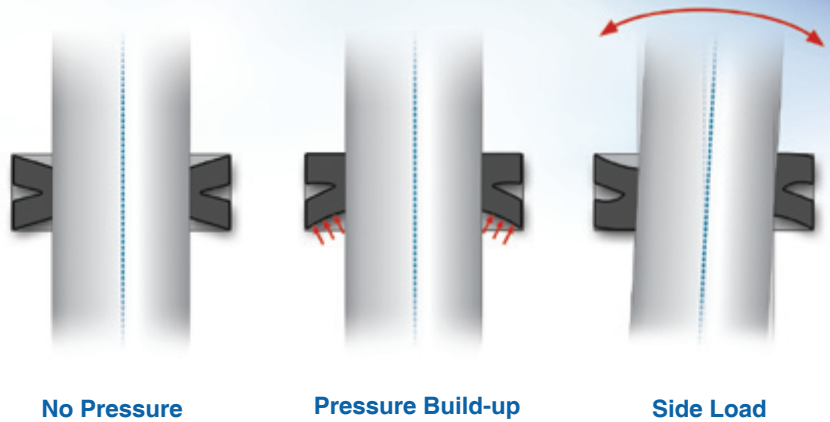

Advantages

- Environment - friendly
- Safe - Meets ISO 15848-1** for eliminating fugitive emissions
- Patent - pending Hermetix™ gland packing and seal
- ZERO-Stem-Leak Hermetix™ valves are now Habonim standard, putting Habonim at the industry forefront in saving our environment
- Anti-static as standard
- **4-Year guarantee against stem leakage!**

Additional Features of the ZERO-Stem-Leak HermetiX™ Valve

- As standard, the HermetiX™ seal is comprised of an NRG (carbon-filled PTFE) and carbon-filled PEEK thrust bearing. For FDA and other clean applications (where carbon particles are prohibited), a TFM HermetiX™ gland packing and Virgin PEEK thrust bearing is available.

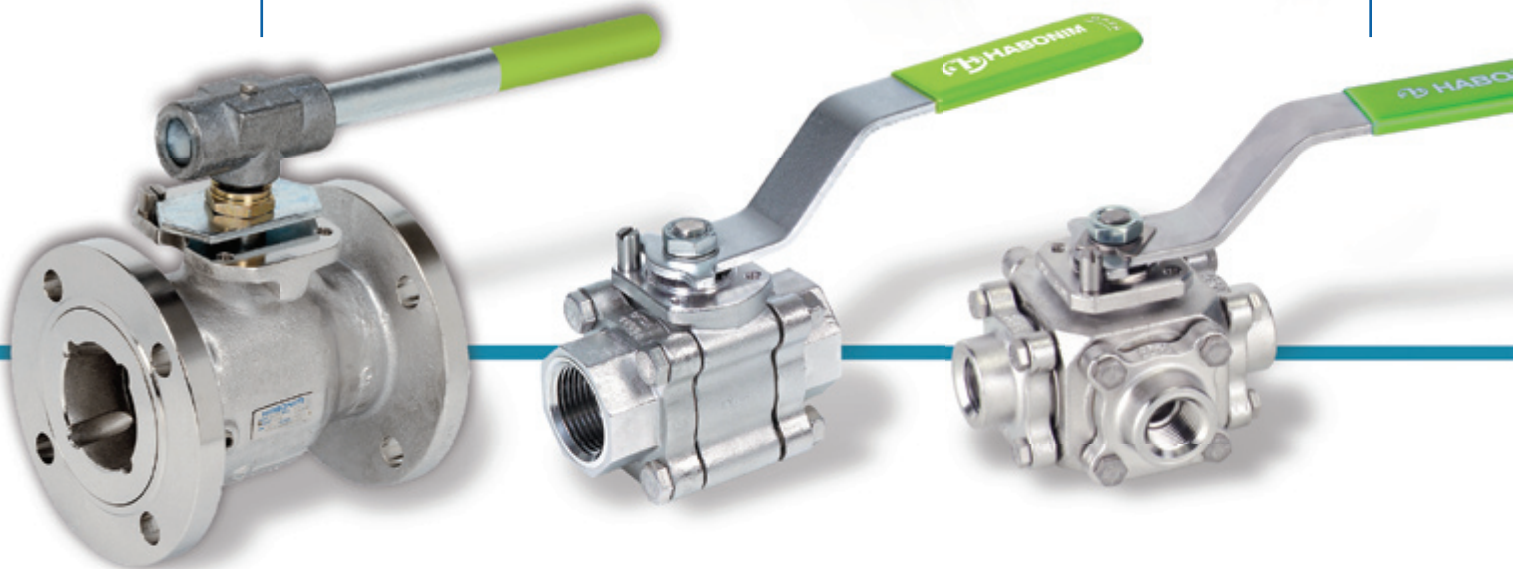
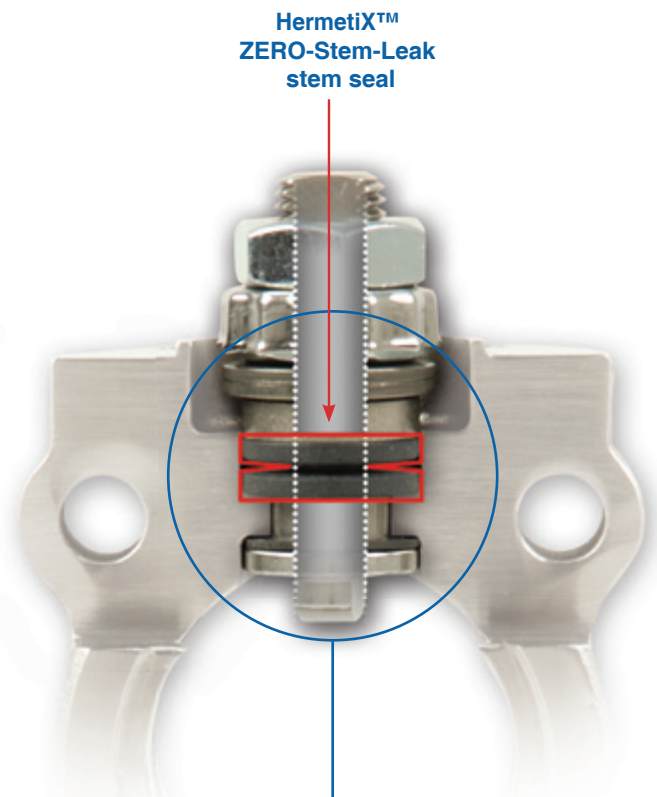



HERMETIX™

ZERO-Stem-Leak Valve Series

The following valve families feature the ZERO-Stem-Leak HermetiX™ technology (NON-Fire-Safe versions):

- 47X (3-piece)
- 31X (flanged, reduced port, #150)
- 32X (flanged, reduced port, #300)
- 73X (flanged, full-port, #150)
- 74X (flanged, full-port, #300)
- 77X (DIN, flanged, full-port, PN16)
- 78X (DIN, flanged, full-port, PN40)
- 61X (3-way), 62X (4-way) (multiport)

Ordering Information

The HermetiX™ designation “X” replaces “P”, thus 47X, 31X, 73X for example.

Availability

All valves designated above will be supplied with the HermetiX™ stem seal as standard after February 2009.

All Habonim ZERO-Stem-Leak Valves are fitted with a distinctive green handle

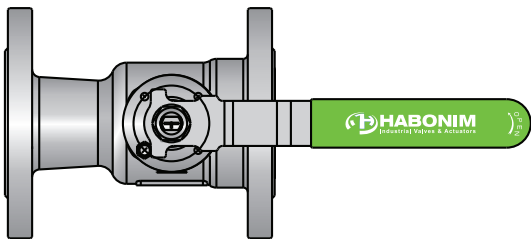

For additional information,
please contact
sales_international@habonim.com,
or your local Habonim distributor.



Headquarters Habonim ISRAEL
Tel: +972-4-6914911, Fax: +972-4-6914902
sales_international@habonim.com

ISRAEL
Tel: +972-4-6914903
Fax: +972-4-6914935
sales_israel@habonim.com

www.habonim.com

North America
Habonim USA
Toll Free Phone: 1-866-261-8400
Toll Free Fax: 1-866-243-9959
sales_usa@habonim.com

Europe
Habonim Europe
Tel: +972-4-6914733
Fax: +972-4-6914703
sales_europe@habonim.com

U.K.
Habonim UK
Tel: +44-1633-484554
Fax: +44-1633-482252
sales@habonimuk.com

