

## : radraft

## Drafting Solution

Radraft provides users with a comprehensive drafting solution for all your 2D design and drawing needs. Although easy to use, Radraft has many advanced features to assist with the quick production of drawings and parts. With its compact GUI (Graphical User Interface), users can access a wealth of drawing tools and parametric profiles.

**Productive Engineering Drawing**

Radraft is a highly productive tool that will meet all your engineering drawing needs. The full toolset of drafting functionality is available for all other 2D geometry tasks within Radan. Whether it is a drawing, a sheet metal profile in Radan 3D, a sheet metal part in Radpunch or Radprofile, the full power of Radraft geometry construction tools are available. The standard toolset made available in Radraft, reduces training requirements, eases deployment and delivers higher productivity.

**Intelligent Profile Healing**

When transferring data between CAD systems, the integrity of the lines and arcs are all important; especially when this data is intended for use in downstream manufacturing.

Radraft is highly accurate and produces drawings of the highest quality. Unfortunately this is not the case for all CAD systems and file formats. This is why Radraft comes with a set of sophisticated, yet simple-to-use Geometry Utilities.

When importing data from other CAD or CAM systems, and considering your specified tolerances, the Automatic

Geometry utility will check for and close small gaps in the profiles, trim back overlapping lines and arcs and remove duplicated lines or arcs. It can also remove unwanted text and dimensions, if required.

**Compact User Interface**

Radraft's compact user interface presents the user with a complete set of drawing tools organized in a logical way. Similar commands are grouped together and sub menus appear only when required and applicable to the task at hand.

Radraft is quick and easy to learn and a highly productive drawing tool. Simple graphical icons lead the user to all of the drawing commands with the addition of flyout tool tips to assist new or infrequent users. Backed up by an online manual and context sensitive help, users will be producing quality drawings in the shortest possible time.

**Features include**

Fully featured 2D draughting package

Very quick and easy to use

Compact yet fully featured Graphical User Interface

Supplied with a library of parametric engineering profiles

Exchange drawings via DWG, DXF and IGES

Parametric dimensioning

Parametric expressions

Automatic profile healing

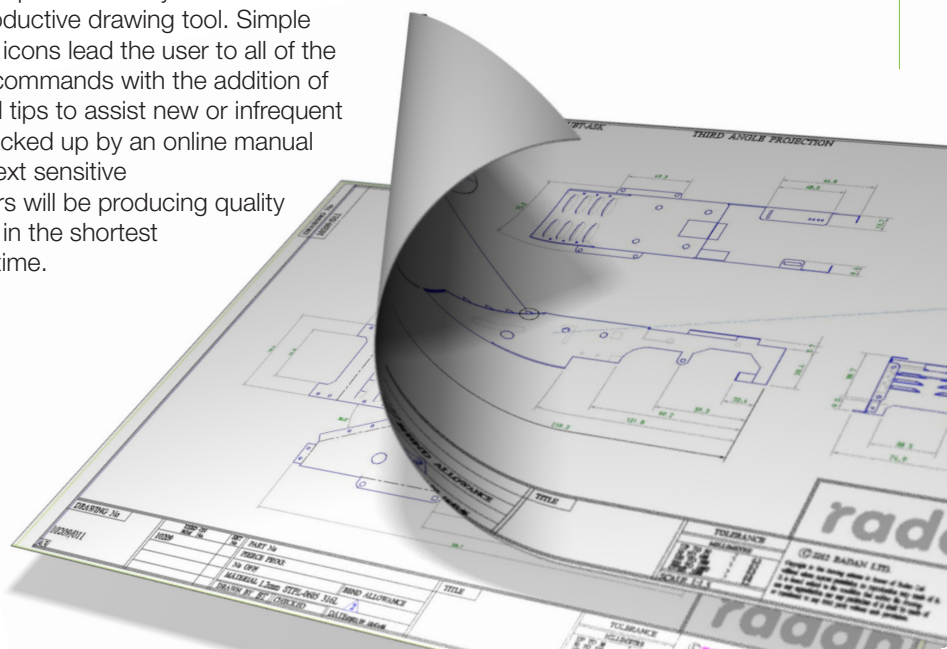

Creating quality drawings using Radraft could not be simpler. Radraft has been specifically developed with manufacturing in mind to assist in the production of engineering drawings and comes with a wealth of standard engineering profiles and simple to use functions.

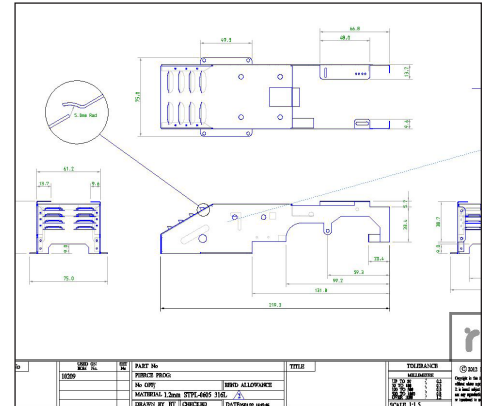
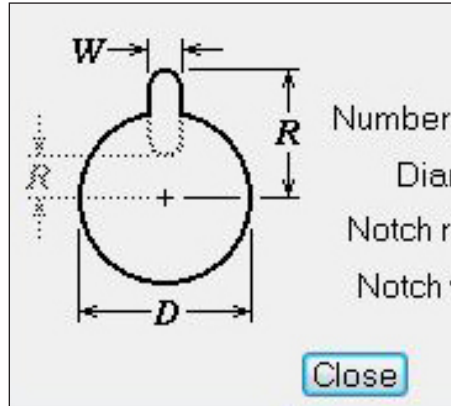
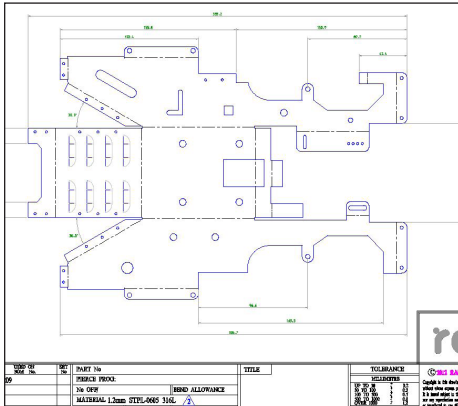

### Intelligent Profile Smoothing

Radraft's Geometry Utility can simplify or smooth the geometry profiles. Some file types can't support complicated splines or arcs and consequently represent these by using many very short straight line segments. Such profiles can be difficult to work with and can cause problems when trying to apply tooling in the manufacturing process.

Working within your specified tolerances, Radan's Geometry Smoothing Utility will replace these many short line segments with smooth tangential arcs while maintaining the original shape of the profile.

This has the effect of making these profiles much simpler to work with, and can dramatically improve the quality of this geometry for use in the manufacturing process. It can also have the effect of greatly reducing file size.

Radan's Geometry Utilities can greatly speed up the process of cleaning and working with imported data, greatly improving drawing productivity and quality.

### Snap & Latch Controls

Intelligent and easy to control latch and snap settings allow the user to quickly construct drawing profiles.

Automatic Horizontal, Vertical and point snapping, among others, allow the user to be quick but highly accurate when constructing geometry. In addition, middle mouse Zoom, Pan and Redraw combine to make Radraft an efficient and highly productive drawing tool.

### Text and Annotation

Radraft facilitates the quick and easy manipulation of multi and single line text. With access to your true type fonts, Radraft enables the quick production of drawing notes and annotation.

Standard notes can be saved as symbols for later retrieval on the same drawing or used across multiple drawings. Text can be exploded back to lines and arcs for use in profile cutting in conjunction with Radpunch, Radprofile or used in 3D modelling in conjunction with Radan 3D.

### Drawing Attributes

Radraft drawings come with a host of standard and customizable attributes. These attributes can be used to store and retrieve valuable information about the drawing such as revision, drawn by, material, etc.

Attributes can be customized to hold specific information about the drawings and parts and if necessary can be made mandatory ensuring consistency across the drawing office.

### Parametric Dimensions

Radraft offers full parametric dimensions allowing the user to modify drawings and geometry by simply editing a dimension value. This facility can dramatically speed up the editing process.

### Parametric Expressions

For those who wish to go a stage further, Radraft offers Parametric Expressions. This feature allows the user to name some or all dimensions and then create mathematical expression to control these dimensions. Multiple versions can be created and stored, this is ideal for creating variations on a theme or developing whole families of parts.

### Radan

25 North Lake Street  
Suite 220  
Forest Lake, MN  
55025  
U.S.A

tel. (800) 875-7232

email. [radansales@radan.com](mailto:radansales@radan.com)

web. [www.radan.com](http://www.radan.com)

radan

## : radan 3D

### 3D sheet metal design and automatic unfolding

Radan 3D is a high performance and versatile 3D modelling package designed to make sheet metal design and engineering assembly modelling simple.

#### 3D Sheet Metal Design

The software is specifically focused on the rapid creation and modification of 3D sheet metal parts and assemblies. The system understands the attributes of sheet metal and utilizes user-definable parameters for precise automatic unfolding.

Based on the ACIS solid modelling kernel and employing modern parametric techniques, it provides design flexibility and a unique 2D-to-3D method of creating 3D objects.

In addition, Radan 3D allows the import of a range of file formats, including Inventor, Solidworks, Catia V4 & V5, SAT, IGES, STEP and Parasolid, as well as the creation of assemblies in the 3D environment.

The Radan 3D model can be updated with manufacturing information such as expected radius and setback values from Radbend, Radan's offline programming solution.

#### Automatic Unfolding

Parts can be unfolded directly into the sheet metal part editor, ready for onward processing. This enables a smooth and efficient workflow from design to manufacture.

Unfolding parameters, such as bend allowances, can be controlled independently of the geometry, enabling an accurate development that is based on actual bending machines and tooling to be used in production. This leads to more accurate flat blanks, more accurate folding and ultimately, a higher quality product.

#### Benefits include :

- Specialized sheet metal assembly design
- Design errors eliminated
- Accurate automatic unfolding, even with imported models
- Increased production flexibility
- High quality data import with optional geometry healing
- High productivity

#### Features include

User-defined bend allowances

Flexible design changes including material thickness

Automatic, associative drawing elevations

Associative 2D dimensioning on drawing elevations and flat blanks

An integrated component of Radan

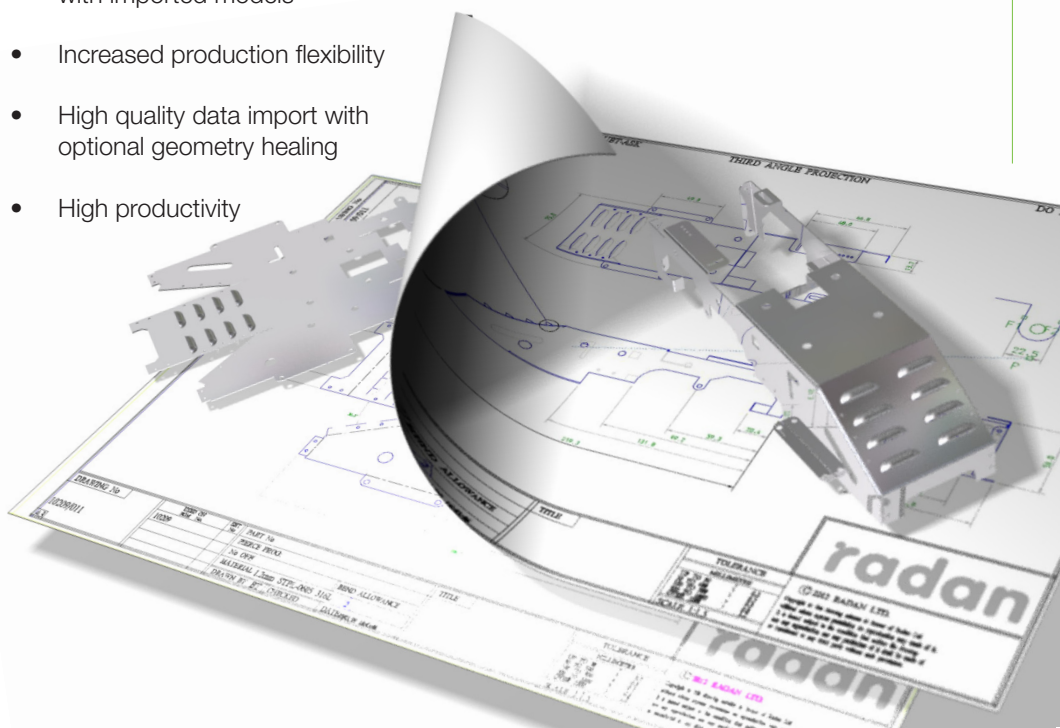

Radan 3D is a simple to use 3D design tool. It is ideal for the design of sheet metal parts and assemblies. However it doesn't have to stop there, Radan 3D is an all around 3D modelling tool that can handle all of your 3D design and modelling requirements.

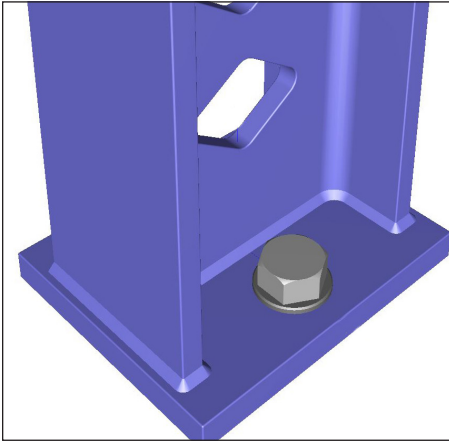

#### Sheet Metal Unfolding

The unfolders can flatten models, such as intersecting cylinders, producing complex profiles in the developed shape. In order to manufacture such shapes efficiently on CNC machinery where the cutting entities available are typically lines and arcs, the software can automatically translate these complex profiles into a series of lines and arc elements. The process is designed to create the minimum number of geometries necessary to make the part to the required accuracy. The benefit is shorter programs and better quality parts.

#### Full Assembly Modelling

Radan 3D is ideal for modelling simple or complex assemblies. Parts can be grouped together in assemblies or sub-assemblies within the model or can be saved and used across multiple models and assemblies. Radan 3D supports both the Bottom Up and Top Down approach to 3D modelling

#### Bottom Up

Radan 3D can be used in the Bottom Up approach. This means the user can design each part in isolation and then bring them all together to form large assemblies.

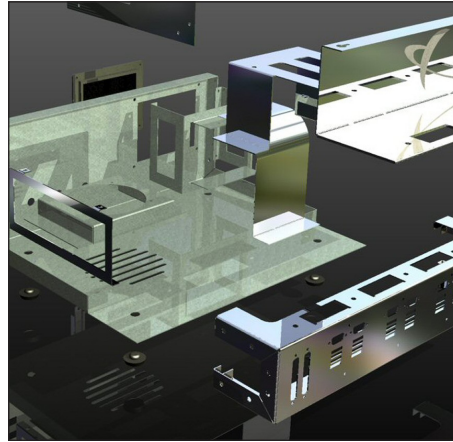

#### Top Down

Alternately Radan 3D can be used in a Top Down approach. This means that the user can work within the assembly designing parts in context ensuring correct function and fit.

#### Fold Up From Flat

Radan 3D has a powerful utility that allows users to take existing 2D blanks and fold them up into 3D sheet metal models. Working from your bend allowances, the Fold Up from Flat utility will scan any 2D blank drawing looking for external profiles and bend lines. It will then create an accurate 3D sheet metal model from this 2D drawing.

Once created, this model can be edited in the normal way. This really is the most productive way to re-engineer existing blank data.

#### Integrated CAD/CAM

Radan 3D will stand alone as a powerful and productive modelling tool. However, Radan 3D can be fully integrated into Radan's suite of manufacturing products offering truly integrated CAD/CAM.

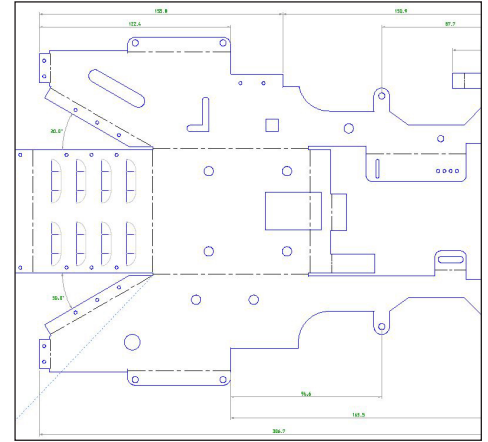

#### Tool Detailing

The unique multi view feature in Radan 3D offers the user the ability to turn 2D orthographic views into a 3D model.

Simply extract profiles from an existing 2D drawing or draw two or more 2D views of an object, press the button and Radan 3D will convert these views into a 3D model. It really is the quickest and simplest way to go from 2D to 3D.

#### Accurate Design

To ensure accurate and flexible 3D design, Radan has the following key features :

- Parameter driven design
- Automatic addition of bends
- Advanced corner treatment with sheet overlaps or "airtight" corners
- Merge face function to join complex corners
- User defined blend allowances with global update

#### Radan

25 North Lake Street  
Suite 220  
Forest Lake, MN  
55025  
U.S.A

tel. (800) 875-7232

email. [radansales@radan.com](mailto:radansales@radan.com)

web. [www.radan.com](http://www.radan.com)

## : genesis profile

CNC profiling for your existing CAD Solution

Genesis Profile provides the perfect CAM solution if you are planning to utilize your current CAD investment. It cost effectively provides your operators with the World Class Radan CAM solution they require to reduce lead times and optimize your lasers, plasmas, water jets and flame cutting machines.

### Seamless Programming

Genesis Profile seamlessly integrates the whole programming process from part nesting, cut path profiling, sequencing, code generation and finally DNC connectivity to the machine controller.

### Accuracy and Consistency

Material specific lead-ins, lead-outs, tagging, machine tool specific cutting technology data and material nesting characteristics are stored in the Manufacturing Database (MDB) in readiness for instantaneous distribution when required to assist an operator or automated process.

### Process Optimization

Genesis Profile intelligently applies the profile tool paths automatically at the nesting stage to maintain the quality and integrity of your parts, while also optimizing the cutting sequence and ensuring cutting head safety, thus enabling the machine tool to perform to its optimum potential.

### Power and Control

The power of automation with the ability to control by your preferences. The Genesis Profile programming solution provides your operators with easy to use software that can be educated to adopt your preferred practices and processes.

### Efficiency is Everything

A machine tool is only as efficient as the software driving it, so that is why we personally install every Genesis Profile post processor to ensure that it is commissioned to match your machine tool and controller.

It is your production efficiency that it's controlling, and that's why your software is important to us.

### Features include

Drag and drop data input

Batch processing of DXF/DWG

Smart Order lead-ins - maximize safety/reduce runtimes

Automatic Hazard avoidance maintaining head safety

Intelligent tagging of components and scrap

Bridge cutting – reduced costs/times

Automatic common line cutting

Automatic remnants, sheet scrapping and off-cuts

Project Nesting incorporating user definable reports

Graphical program verification

Simple intuitive interface with clear simple icons

Reduced lead times and increased production flexibility

Upgrade options for advanced Radan Solutions

### Radan

25 North Lake Street  
Suite 220  
Forest Lake, MN  
55025  
U.S.A

tel. (800) 875-7232

email. [radansales@radan.com](mailto:radansales@radan.com)

web. [www.radan.com](http://www.radan.com)

# radan



## : genesis punch

CNC punching for your existing CAD Solution

Genesis Punch provides the perfect CAM solution if you are planning to utilize your current CAD investment. It cost effectively provides your operators with the World Class Radan CAM solution they require to reduce lead times and optimize your punch machine tools.

### Seamless Programming

The seamless process delivered by Genesis Punch provides an easier to use experience for your operators, while accuracy and consistency of programming is maintained with the collation of process critical data in the Manufacturing Database (MDB). Material, tooling and machine tool specific data are stored in the MDB in readiness for instantaneous distribution when required to assist an operator or automated process.

### Tooling Optimization

Genesis Punch orientation specific tooling permits multiple tooling setups to be applied to a part for different nesting orientations. This enables the downstream nesting process to fully optimize material utilization by part rotation, which may have otherwise been restricted due to tool rotation limitations. Minimizing programming lead time identification and manipulation of tooling is paramount to an operator. Radpunch provides this capability with the user customizable interactive tool list. The easy to use interface enables an operator to quickly identify and interact with tooling at process critical stages.

### Power and Control

The power of automation with the ability to control by your preferences. The Genesis Punch programming solution provides your operators with easy to use software that can be educated to adopt your preferred practices and processes. If material utilization is critical to your business, upgrading the nester to Radnest (our true shape nester) will raise your material utilization while also providing further advanced nesting tools for your operator.

### Efficiency is Everything

A machine tool is only as efficient as the software driving it, so that is why we personally install every Genesis Punch post processor to ensure that it is commissioned to match your machine tool and controller.

It is your production efficiency that it's controlling, and that's why your software is important to us.

### Features include

- Drag and drop data input
- Batch processing of DXF/DWG
- Automatic tooling/sequencing
- Automatic part removal
- Graphical program verification
- Single Part True Shaped Nesting
- Project Nesting incorporating user definable reports
- Simple intuitive interface with clear simple icons
- Support for your machines advanced features
- Improved machine/tooling efficiency
- Reduced lead times and increased production flexibility

### Radan

25 North Lake Street  
Suite 220  
Forest Lake, MN  
55025  
U.S.A

tel. (800) 875-7232

email. [radansales@radan.com](mailto:radansales@radan.com)

web. [www.radan.com](http://www.radan.com)

# radan

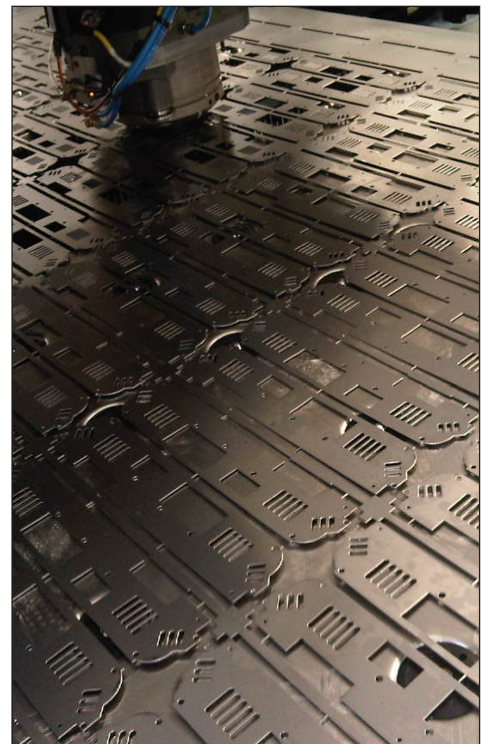

# : radpunch

CNC programming for all your punch machines

Radpunch is machine independent and designed to provide your operators with the tools they require to reduce lead times and optimize your punching machines. Designed to seamlessly integrate with Radprofile, the Radan punch/profile solution delivers optimization for punch, profile and combination machine tools. This combination will expand with you to program all your future punch, laser, plasma, router and combination machine tool investments from one system.

## Seamless Programming

Radpunch seamlessly integrates the whole programming process of geometry creation, tooling, nesting, sequencing, code generation and finally DNC connectivity to the machine controller. The seamless integration delivered by Radpunch provides an easy to use experience for your operators, while accuracy and consistency of programming is maintained with the collation of process critical data in the Manufacturing Database (MDB). Material, tooling and machine tool specific data are stored in the MDB in readiness for instantaneous distribution when required to assist an operator or automated process. Understanding the sophistication and the limits of each machine tool individually is the key to driving it efficiently; Radpunch will assist your operators to optimize your manufacturing capacity to within those limits for all of your machines from a single system.

## Tooling Optimization

Optimizing the tooling used by a punch machine is paramount to the efficient programming of a punch machine and thus the reduction of the cost to manufacture a part. Simply optimizing conventional tools on a part and their location in the turret or tool rail is no longer sufficient, as tooling suppliers are providing more sophisticated tooling such as close to clamp slitters,

wheel tooling, de-burring tools, scribes and flexible part marking tools. Radpunch understands the constraints of tools and the necessary NC codes required to support them.

Radpunch orientation specific tooling permits multiple tooling setups to be applied to a part for different nesting orientations and different machine tools. This enables the downstream nesting process to fully optimize material utilization by part rotation which may have otherwise been restricted due to tool rotation limitations. The same functionality also optimizes preparation of parts for removal processes on more sophisticated machine tools. While a part may be capable of dropping down a chute or being picked at one orientation, at another orientation it may not be suitable. Orientation specific tooling enables the appropriate part removal processes to be applied to complement the part orientation during nesting.

To minimize programming lead time, identification and manipulation of tooling is important to an operator. Radpunch provides this capability with the user customizable interactive tool list. The easy to use interface enables an operator to quickly identify and interact with tooling at process critical stages.

## Features include

Drag and drop data input

Batch processing of DXF/DWG including healing

Automatic tooling/sequencing

Automatic part removal

Graphical program verification

Single part true shaped nesting

Project nesting incorporating user definable reports

Quick estimates for parts or nests

Simple intuitive interface with clear simple icons

Supporting machines advanced features

Improved machine/tooling efficiency

Reduced lead times and increased production



Understanding the sophistication and the limits of each machine tool individually is the key to driving it efficiently; Radpunch will assist your operators to optimize your manufacturing capacity to within those limits for all of your machines.

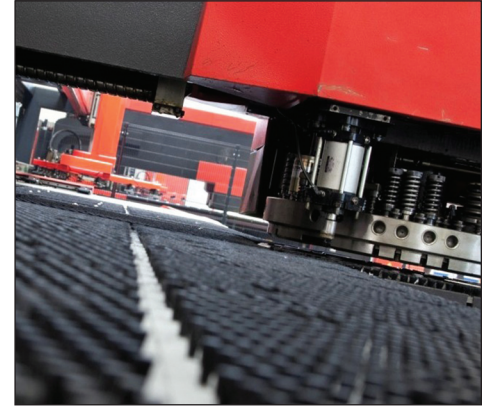
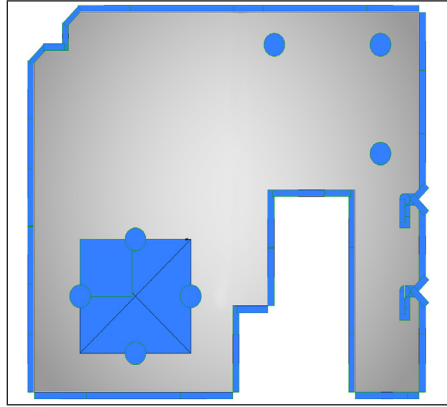
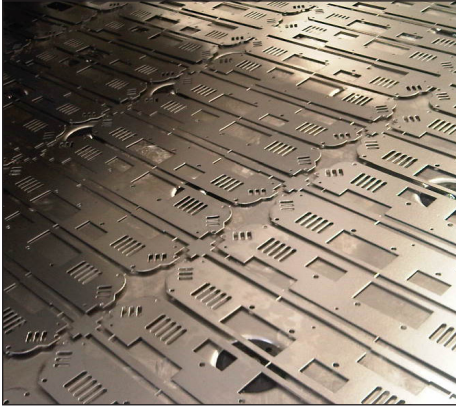

#### Power and control

The power of automation with the ability to control by your preferences. The Radpunch programming solution provides your operators with easy to use software that can be educated to adopt your preferred practices and processes. Tool selection, tagging, preferred removal procedures, preferred punching sequences, and more can be defined relative to material type, thickness and machine tool in the Manufacturing Database (MDB). The MDB expands with your business. The introduction of new customers, new products or new machines brings into your manufacturing environment the need to control new material, tooling and new practices. The MDB ensures consistency of programming for these new criteria for all of your machines which translates to less rejects, less rework and higher returns.

If manual control is your preference, this is in abundance with Radpunch. An operator can take full control of the programming process at any stage. The ability to interact manually and override any of the automated processes gives a Radpunch user the power to tackle the most difficult jobs with ease and confidence.

The fully integrated Project Nester provides your operator with an instantaneous overview of your punching demand. Automatic rectangular nesting, single part true shape nesting, and manual drag and drop nesting techniques enable your operator to quickly, easily and efficiently meet your ever-changing production and customer demands. If material utilization is critical to your business, upgrading the nester to Radnest (our true shape nester) will raise your material utilization while providing further advanced nesting tools for your operator.

#### Efficiency is Everything

Radpunch is a fast, modern programming application designed and written by Radan to assist a programmer in transferring data from CAD to NC code. The seamless interface, and the automatic processes all assist the operator. Unfortunately in reality, production workflow is not always that consistent. Problems downstream, manufacturing change requests, and rework requests all require an operator to be fast and efficient. Radpunch enables an operator to jump into the programming process at the point where the change

is required; but it does not necessarily demand that the whole programming process is repeated.

A machine tool is only as efficient as the software driving it, so that is why we personally install every Radpunch post processor to ensure that it is commissioned to match your machine tool and controller. It is your production efficiency that it is going to be controlling, that's why your software is important to us.

#### Radan

25 North Lake Street  
Suite 220  
Forest Lake, MN  
55025  
U.S.A

tel. (800) 875-7232  
email. [radansales@radan.com](mailto:radansales@radan.com)  
web. [www.radan.com](http://www.radan.com)



# : radprofile

CNC programming for your laser, plasma, waterjet and flame cutting machines

Radprofile provides your operators with the tools they require to reduce lead times and optimize your laser, plasma, waterjet and flame cutting machines. Designed to seamlessly integrate with Radpunch, the Radan punch/profile solution delivers optimization for punch profile combination machine tools.

### Seamless Programming

Radprofile seamlessly integrates the whole programming process of geometry creation, nesting, cut path profiling, sequencing, code generation and finally DNC connectivity to the machine controller. The seamless integration delivered by Radprofile provides an easier to use experience for your operators, while accuracy and consistency of programming is maintained with the collation of process critical data in the Manufacturing Database (MDB). Material, lead-ins, lead-outs, tagging, and machine tool specific cutting technology data are stored in the MDB in readiness for instantaneous distribution when required to assist an operator or automated process. Understanding the sophistication and the limits of each machine tool individually is the key to driving it efficiently; Radprofile will assist your operators to optimize your manufacturing capacity to within those limits for all of your machines.

### Process Optimization

Optimizing the tool path, cutting technologies and cutting sequence for a profiling machine is paramount to the efficient programming of the machine and thus the reduction of the cost to manufacture a part. As profiling machines, (particularly laser profiling machines) become faster and more sophisticated, the integrity of the part in the nest sheet and the safety of the machine head become even more important.

Radprofile intelligently applies the profile tool paths automatically at the nesting stage to maintain the quality and integrity of your parts, while also optimizing the cutting sequence and ensuring cutting head safety, thus enabling the machine tool to perform to its optimum potential.

Radprofile supports automatic common line cutting. This enables the downstream nesting process to fully optimize material utilization while also benefiting from reduced cutting times and gas costs. Parts identified for common cutting can be controlled to cut in clusters to maintain sheet rigidity and remove tolerance problems associated with common cutting in large quantities.

### Features include

Drag and drop data input

Batch processing of DXF/DWG

Smart Order lead-ins - maximize safety/reduce runtimes

Automatic Hazard avoidance maintaining head safety

Intelligent tagging of components and scrap

Bridge cutting – reduced costs/times

Automatic common line cutting

Automatic remnants, sheet scrapping and off-cuts

Project Nesting incorporating user definable reports

Graphical program verification

Quick estimates for parts or nests

Simple intuitive interface with clear simple icons

Reduced lead times and increased production flexibility



Radprofile intelligently applies the profile tool paths at the nesting stage to maintain the quality and integrity of your parts while also optimizing the cutting sequence and ensuring cutting head safety, to enable the machine tool to perform to its optimum potential.

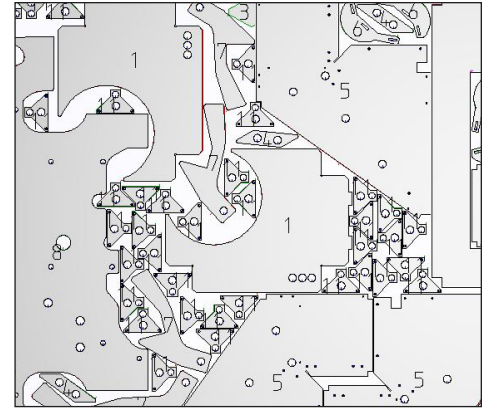
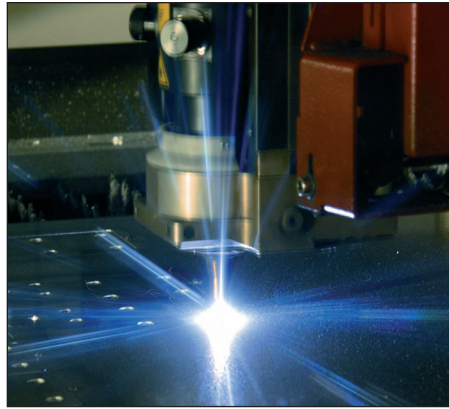
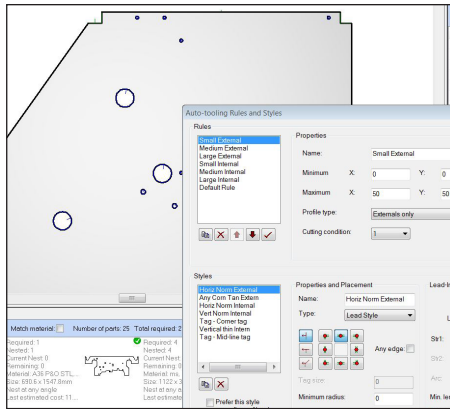

### Power and Control

The power of automation with the ability to control by your preferences. The Radprofile programming solution provides your operators with easy to use software that can be educated to adopt your preferred practices and processes. Lead-in and lead-out preferences, tagging, preferred profiling sequences - all these and more can be defined relative to material type, thickness and machine tool in the Manufacturing Database (MDB). The MDB expands with your business. The introduction of new customers, new products or new machines brings into your manufacturing environment the need to control new material, strategies and new practices. The MDB ensures consistency of programming for these new criteria for all of your machines which translates to less rejects, less rework and higher returns.

If manual control is your preference, this is in abundance with Radprofile. An operator can take full control of the programming process at any stage. The ability to interact manually and override any of the automated processes gives a Radprofile user the power to tackle the most difficult jobs with ease and confidence.

The fully integrated Project Nester provides your operator with an instantaneous overview of your profiling demand. Automatic rectangular nesting, single part true shape nesting and manual drag and drop nesting techniques enable your operator to quickly, easily and efficiently meet your ever-changing production and customer demands. If material utilization is critical to your business, upgrading the nester to Radnest (our true shape nester) will raise your material utilization while providing further advanced nesting tools for your operator.

### Efficiency is Everything

Radprofile is a fast, modern programming application designed and written by Radan to assist a programmer in transferring data from CAD to NC code. The seamless interface and the automatic processes all assist the operator. Unfortunately in reality, production workflow is not always that consistent. Problems downstream, manufacturing change requests, and rework requests all require an operator to be fast and efficient.

Radprofile enables an operator to jump into the programming process at the point where the change is required; but it does not necessarily demand that the whole programming process is repeated.

A machine tool is only as efficient as the software driving it, so that is why we personally install every Radprofile post processor to ensure that it is commissioned to match your machine tool and controller. It is your production efficiency that it is going to be controlling, that's why your software is important to us.

### Radan

25 North Lake Street  
Suite 220  
Forest Lake, MN  
55025  
U.S.A

tel. (800) 875-7232  
email. [radansales@radan.com](mailto:radansales@radan.com)  
web. [www.radan.com](http://www.radan.com)

radan

# : radnest

## Advanced true shaped nesting

Radnest analyzes the true shape, material and thickness of all components in a batch. Separates and sorts automatically to produce highly utilized, manufacturable nests from sheets, off-cuts and remnants to deliver substantial savings in material and increased machine efficiency.

### Radnest for punching or profiling

Radnest is a high performance true shape nester for punching and profiling machines supplementing the nesting utilities present in a standard Radan system. It allows the user to have full control over part placement and nest generation either manually, semi-automatically or fully automatically. Radnest can dramatically increase sheet utilization and significantly reduce the time taken to create nests.

Radnest allows 2D profiles to be imported on mass setting attributes such as material, thickness and quantity. As part of the quick and easy process, files can be cleaned and healed on import removing drawing borders, text and dimensions while closing small gaps and removing rogue geometry. Preferences can be saved into templates allowing you to tailor your import to your customer's data.

Kits can be created within Radan helping avoid parts being missed from assembly lists. Enter which kit you would like to manufacture and how many, Radnest will then explode the kit into its component parts with the correct materials, thicknesses and quantities.

### Profiling with Radnest

When used with Radprofile, Radnest can automatically produce common line cuts between adjacent parts to further increase material utilization and reduce cycle time. Gaps between components are controlled by the kerf width created by a given material, thickness and cutting method for a specific machine. This data is stored within Radan, meaning that complete automation is possible. Radnest is able to mix different nesting techniques on the same sheet. Whether Rigid Kits, Picking Clusters, Common Cutting or Standard Spaced, the result is industry leading nests for today's modern machinery and manufacturing techniques.

### Features include

Increased material utilization with the ability to prioritize sheets

Improved machine efficiency

Reduced lead times through dynamic nesting and enhanced data imports

Automatic material sorting

Automatic remnant usage and tracking

Easy integration and inclusion into your current workflow

Flexible and powerful nest editing tools

Machine specific nests with associated CAM rules

Simple intuitive interface with clear simple icons showing status

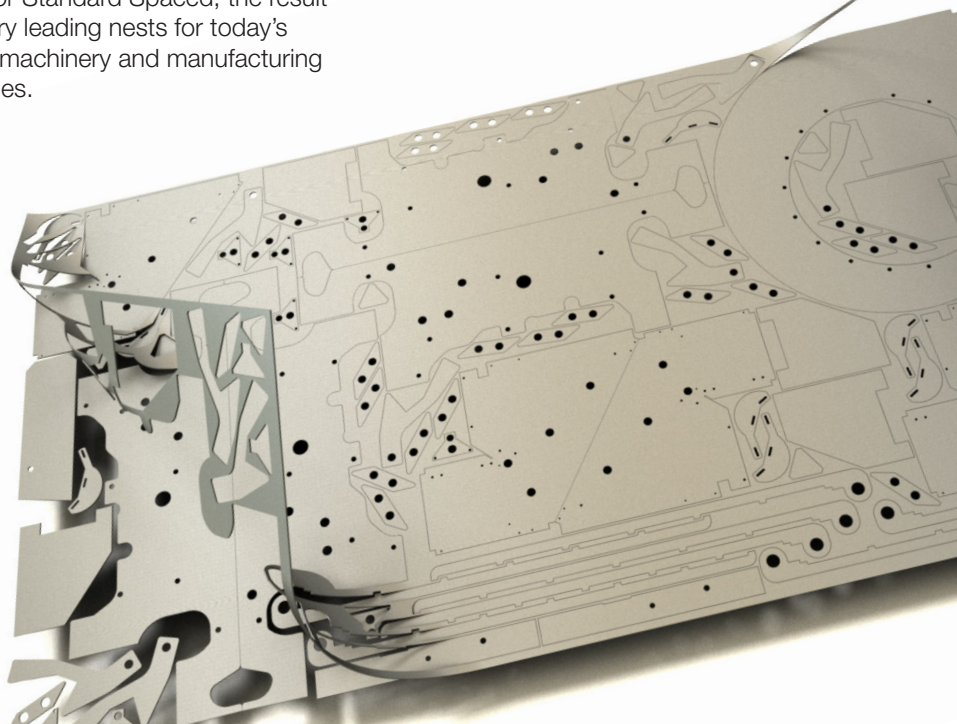

By using Radnest, you can expect to produce more components from less material in less time. The efficiencies gained have a significant effect on profit, enabling you to manufacture parts from material that would have previously been in the scrap bin.

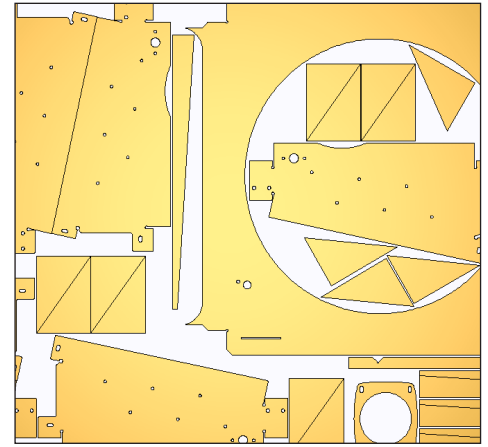
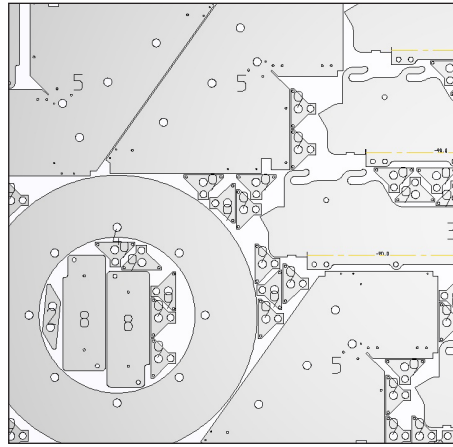
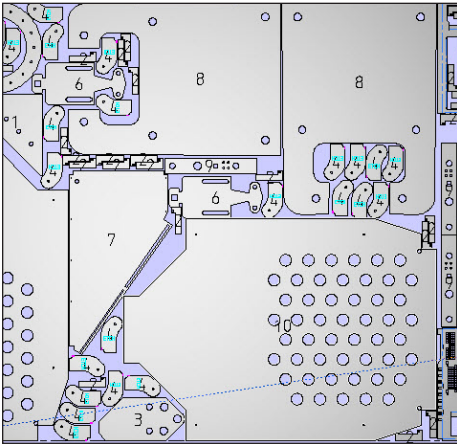

### Advanced Nesting for Punching Machines

When Radnest is used with Radpunch, the tooling for each part is compared against the available stations in the turret or tool changer. This may restrict the orientations at which a part can be placed or mean that a different part is selected for the current nest. It is extremely important that the nest produced does not exceed the tooling capacity of the machine tool, as this would result in a program that could not be run. Radnest can analyze the geometry of punch tools used on parts enabling accurate spacing of components based on the distance between tool hits rather than the conventional part spacing, allowing parts to be nested closer together while still maintaining rigidity in the sheet and removing the danger of large external tools entering a neighboring part.

Reading the data stored on Radan geometry is another way that Radnest improves the accuracy and reliability of nesting within an organization, Radan parts can have orientation restrictions, common cutting rules and removal data embedded onto them for any machine tool. Radnest is able to extract this data and use it in context

based on the machine the nest is being created for. Radnest enables manufacturing flexibility that is unrivalled in our industry by using the information available to create the best manufacturable nest possible for any punching or profiling machine.

### Power and Control

Radnest will keep track of components that have been nested and materials available. If the user decides that they do not want a nest for some reason, they can just delete it prior to manufacture. Any parts that were on the nest will return to the waiting list of parts, and the material will return to the stock list. At any point, the user can take manual control and place parts into a sheet or remnant. Radnest will keep a count of what has been done and modify the requirements accordingly. Manual placement of parts is interactive with Radnest keeping control of component spacing if required. Simple functions like filling the free area of a sheet with stock or extra components can be accomplished easily either manually or automatically.

Radnest can place parts onto a sheet of any shape and areas of a specific sheet can be marked as unusable, whether that is

because a component has been cut out or the sheet is defective for some reason. When nests are created that have an amount of free sheet remaining, Radnest can automatically create a remnant. This remnant can be true shape being exactly the skeleton created, a rectangle trimmed to the last component on the nest or to a predetermined size in a range of sizes. Radnest will automatically store and use remnants as required with the user able to create bias helping to avoid the accumulation of remnants.

### Efficiency is Everything

Radnest is a fast, modern nesting application designed and written by Radan to get the absolute best from available options while still allowing a human touch when required. This is crucial in fast moving, ever changing production environments. Radnest uses very modern and complex nesting algorithms to make decisions about parts being nested, the materials available and the machine running the program. To do this effectively, it uses all of the computing power available, fully utilizing today's modern multi-core processors to get the most cost efficient result in the shortest time.

### Radan

25 North Lake Street  
Suite 220  
Forest Lake, MN  
55025  
U.S.A

tel. (800) 875-7232  
email. [radansales@radan.com](mailto:radansales@radan.com)  
web. [www.radan.com](http://www.radan.com)

radan

## : radbend

Offline programming and simulation for press brakes

Radbend from Radan is the comprehensive offline programming solution for Press Brakes. Completely integrated with Radan 3D, it also provides a full 3D simulation of the bending process.

#### Offline Programming

Radbend enables full, accurate 3D-model simulation of the bending process, including advanced features such as automatic bend sequence calculation, automatic tool selection and automatic fingerstop placement, offering simple programming and high productivity.

The ability to program and verify bending operations offline frees up valuable machine time and improves first-off reliability, reducing manufacturing costs. Radbend also eliminates costly mistakes with automatic detection of collisions with both tooling and the machine tool itself.

Radbend is available to provide offline programming and simulation of a wide variety of press brake machinery. Radbend can create full shop floor documentation in print form or a file for viewing on a shop floor viewer and DNC system ensuring access to only controlled data from production office through to shop floor resulting in a 'right first time' manufacturing approach.

#### Highly Automated

Radbend features high levels of automation. The system examines the part to be programmed and automatically determines a bending sequence taking into account part geometry and best machinery practice.

In addition, fingerstop positions are set automatically to provide reliable positioning.

Radbend's tooling library can incorporate a tooling manufacturer's complete inventory, enabling nonstandard tools to be tested and proven on new products before purchase.

#### Features include

Automatic bend sequencing

Automated tool selection

Tool setup optimization

Automatic fingerstop positioning

Customizable reports

Support for lifting aids and angle measurement systems

Can be integrated with Radan3D



Press brake independent, Radbend can help you to reduce bottlenecks and costs, while increasing efficiency and productivity by enabling you to program and verify your bending operations offline as well as detecting any collisions with the tooling, finger stops and the machine tool itself.

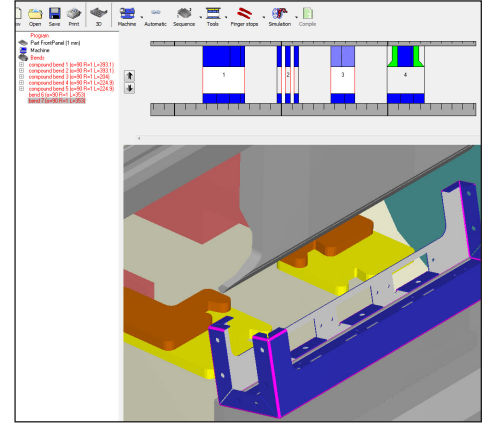
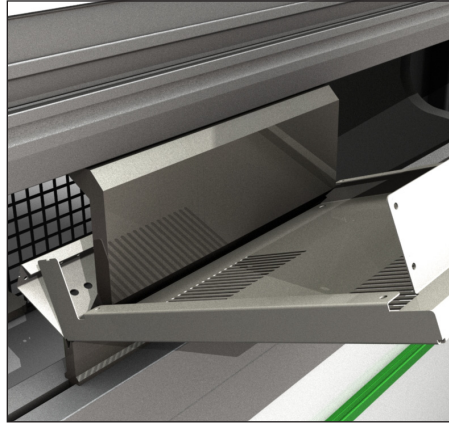
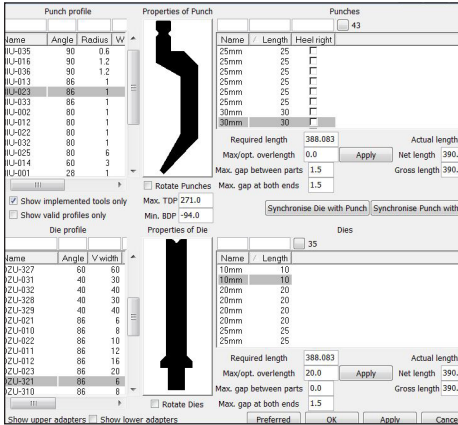

### Machine Independent

Radbend is totally press brake independent. Users are able to program all of their press brakes from one common interface. This offers great flexibility where users can quickly try out several press brakes to ensure the right machine for the job.

### Data Import

Radbend can import data in a range of 2D and 3D formats as well as having specific plug-in interfaces for well known 3D CAD systems.

### Autodesk Inventor Plug-in

Autodesk Inventor can be fully integrated with Radbend using the plug-in. The Radbend plug-in offers a seamless, accurate and intelligent transfer of data between these two programs.

Taking your part from Autodesk Inventor into Radbend couldn't be more straightforward. Once you are satisfied with your design, simply click on the Radbend icon and your part and associated information gets transported into Radbend.

### SolidWorks Plug-in

Utilizing the Radbend Plug-in, taking your part from SolidWorks, Standard, Professional or Premium couldn't be more straight forward. Once you are happy with your design, simply click on the Radbend icon and your drawing and associated files are seamlessly transferred into Radbend.

### Increase Productivity

Once your part has been transferred into Radbend, you will be able to:

- Select the most appropriate machine tool and the appropriate tools to bend the part correctly.
- Provide you with consequences of your tool set up - expected radius, press depth, etc.
- Automatically position fingerstops against every valid face requiring fingerstops.
- Run a full 3D simulation of the bending process detecting any collisions and potential problems.
- Automatically generate complete shopfloor documentation, including setup sheets.

### Benefits include :

- Reduce downtime through fast and reliable offline programming
- Reduce lead times due to improved efficiency
- Reduce the setup times of machine tool from the availability of manufacturing information
- Fewer design errors, due to the 3D simulation contained within Radbend
- Avoid costly manufacturing errors by making use of the collision checking
- Machine Independent means that you can easily use Radbend on any of your press brake machine tools
- Open up the press brake to a wider audience of employees
- Accurate automatic unfolding, even with imported models
- Increased production flexibility

### Radan

25 North Lake Street  
Suite 220  
Forest Lake, MN  
55025  
U.S.A

tel. (800) 875-7232  
email. [radansales@radan.com](mailto:radansales@radan.com)  
web. [www.radan.com](http://www.radan.com)

radan

# : radm-ax

multi-axis laser technology for 3D sheet metal components

Radan's Radm-ax is an industry leading 5 axis laser CAD/CAM system developed specifically for the general engineering, automotive and aerospace industries. Radm-ax offers an intuitive environment for the comprehensive programming of multi-axis laser or water-jet cutting machines.

### Extensive Range of CAD Interfaces

Radm-ax comes with an extensive range of integrated CAD data translators that allow the direct import of CAD drawings in their native form or as industry standards, such as IGES, STEP and DXF. The standard system configuration comes with interfaces for DXF, AutoCAD DWG, AutoCAD-Inventor, VISI, SolidWorks, SolidEdge, IronCad and IGES. Optional CATIA V4, CATIA V5, Unigraphics, Pro Engineer, VDA and STEP translators are available. Radm-ax can display the CAD data as simple wireframe, solids and surfaces or a combination of both; which are used as the source for all cut-path programming and process simulation.

### Machine and Database

Radm-ax contains a comprehensive database of laser and water-jet machines from a large number of Machine Tool manufacturers; including NTC, Prima, Trumpf and Amada. Should a machine not be supported, Radm-ax also contains a Machine Setup utility that allows the configuration of bespoke machine types and postprocessing information. The advanced postprocessors aren't just limited to the use of generic G and M codes; posts are easily configured to suit different head configurations and table sizes.

### Automated Fixture Design

Stamped forms typically need to be held using fixtures and within Radm-ax this can be done in a number of ways. One way is to import clamps and fixtures from external files and then manually reposition them. Another way is to use the Fixture Design utility to create the support fixtures using sheet metal. Simply define the number of horizontal and vertical support sheets, how they interlock - including locking features if you require them - and how they run-off the part. Once these details have been defined, Radm-ax creates each sheet, nests them on standard sheet metal sizes, adds assembly notes such as number references and creates the NC code with which to manufacture them.

### Features include

- Intuitive graphical user interface
- Extensive range of CAD interfaces for both import and export
- Comprehensive machine and postprocessor database
- Locate large parts with simplified part location system
- Automated fixture design
- One-click application of toolpath for inner and outer profiles
- Manual application of toolpath for selected areas
- Edit cut technology and nozzle setting at unlimited positions
- Total control of nozzle angle interactively or explicitly
- Create and apply technology data at any point
- Inter- and intra-cut collision detection
- Full solid 3D simulation of machine, nozzle and part

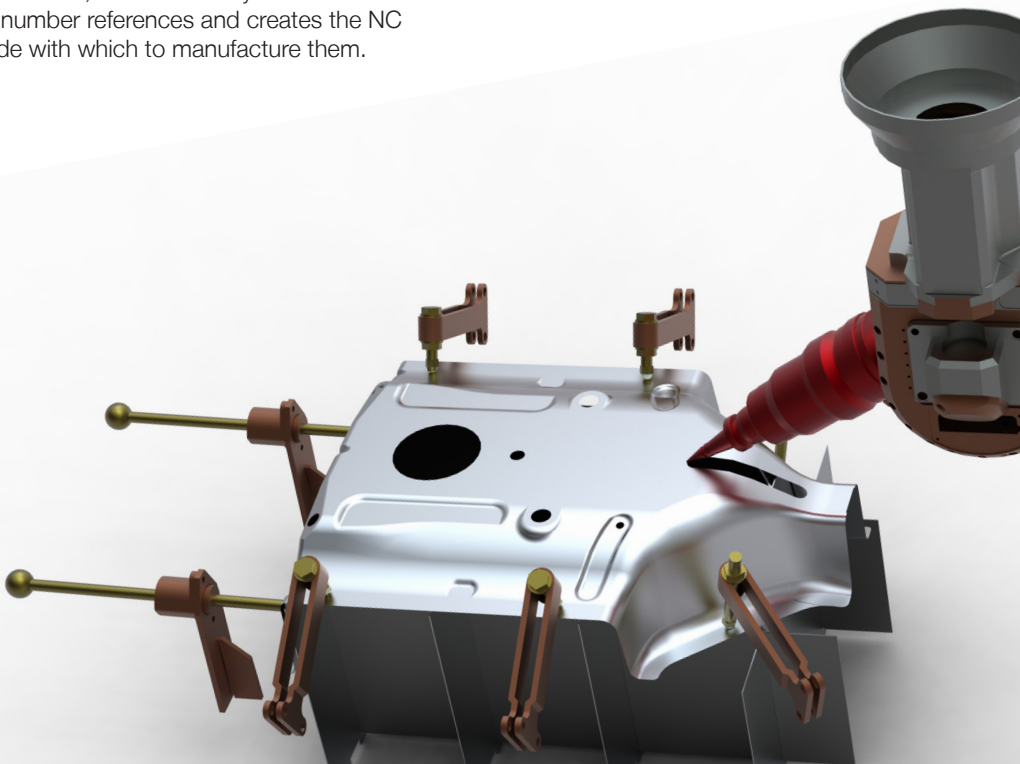

By using Radm-ax, not only will programming time be minimized, the eventual cut-path will be far more efficient, saving further time on the machine. Add in the comprehensive simulation and proofing tools and you have a system that not only streamlines day-to-day production, it also reduces costly errors and eradicates the need for dry-runs.

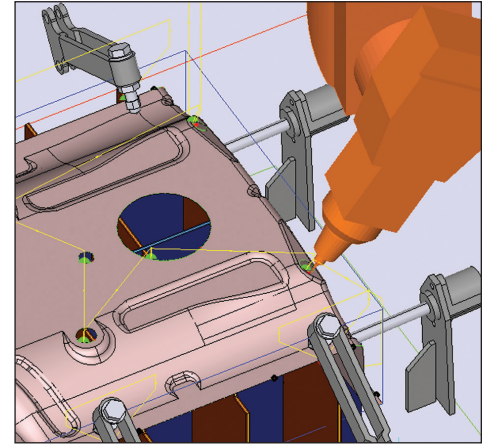
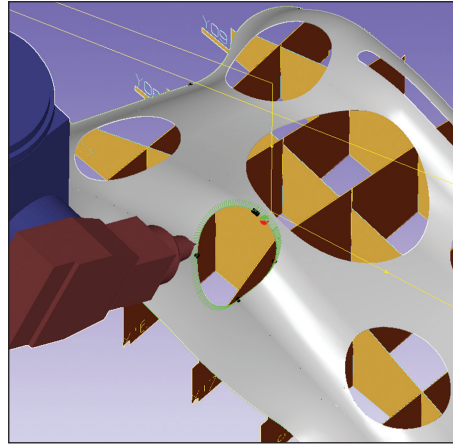
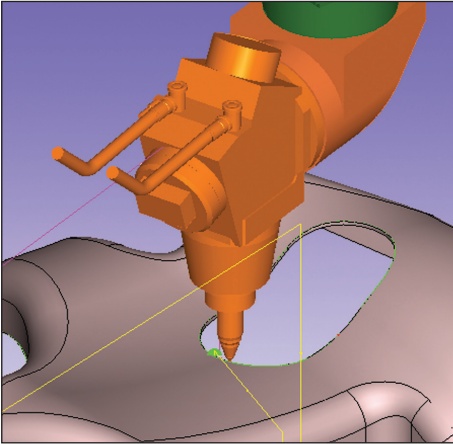

#### Cutting-path Creation

Cutting operations within Radm-ax can generally be divided into two areas: inner and outer trims. Outer trims are the external forms of the part while inner trims represent the internal cut-outs and other features to be machined. The basic toolpaths for these cutting operations can be automatically generated by the automation tools built into to Radm-ax. User interaction is available for all toolpath types to allow for manual creation and refinement. Radm-ax provides a great amount of control over how each inner or outer trim is handled; for example, creating micro-joints to hold the material in place until processing is finished, which becomes quick and uncomplicated. The toolpath can also be edited in terms of how the cutting nozzle is angled towards it or how it handles jigs and fixture features.

#### Reduce Machine Wear

Radm-ax has a wealth of in-built features that allow for the optimization of the laser toolpath. For example, by smoothing out the toolpath in areas around tight corners or small features, Radm-ax will optimize the toolpath to reduce the wear on the machine tool at the same time; ensuring that feeds and speeds are maintained across the job.

#### Toolpath Verification and Simulation

Within Radm-ax the toolpaths are presented showing the angle of the nozzle as it moves around the part. Instant feedback is provided about whether or not a specific move is possible - either in terms of machine head movement limits or accessibility. Any collisions that are detected are highlighted both on the model and via on-screen messages.

The trim-path parameters can be edited directly or, in the event of a collision, automatically corrected at any time; ensuring that your toolpath is both safe and using the optimum strategy to reduce processing time. Once the toolpath has been optimized, simply select the piercing and cutting conditions from the pre-defined technology tables and Radm-ax quickly generates reliable NC code.

#### NC Code Simulation

The NC code can be re-imported into Radm-ax and simulated within the same environment in which it was created. The NC simulation shows how the tool moves through space, allowing the toolpath to be sanity checked before any metal cutting occurs.

#### Radan

25 North Lake Street  
Suite 220  
Forest Lake, MN  
55025  
U.S.A

tel. (800) 875-7232  
email. [radansales@radan.com](mailto:radansales@radan.com)  
web. [www.radan.com](http://www.radan.com)

radan



## : radtube

multi-axis laser technology for tubular components

Radan's Radtube is an industry leading laser CAD/CAM system for rotary and multi axis cutting machines. Radtube was developed specifically for the tube cutting and manipulation industry. The intuitive programming system allows tubes or sections to be parametrically defined from a library of standard shapes into which cutting apertures and profiles can be defined.

#### Extensive Range of CAD Interfaces

Radtube comes with an extensive range of integrated CAD data translators that allow the direct import of CAD drawings in their native form or as industry standards, such as IGES, STEP and DXF. The standard system configuration comes with interfaces for DXF, AutoCAD DWG, AutoCAD-Inventor, VISI, SolidWorks, SolidEdge, IronCad and Solid IGES. Optional CATIA V4, CATIA V5, Unigraphics, Pro Engineer, VDA and STEP translators are available. Radtube can display the CAD data as simple wireframe, solids and surfaces or a combination of both. Solids are used as the source for all cut-path programming and process simulation.

#### Comprehensive Machine and Postprocessor Database

Radtube contains a comprehensive database of laser machines from a large number of Machine Tool manufacturers; including Adige, NTC, Trumpf and Amada. Should a machine not be supported, Radtube also contains a Machine Setup utility that allows the configuration of bespoke machine types and post processing information. The advanced postprocessors aren't just limited to the use of generic G and M codes; posts are easily configured to suit different head configurations and table sizes.

#### Library of Standard Tube Sections

Radtube supplies a library of parametric tube shapes that simplify the creation of the tube material to be cut. If a suitable section does not exist, the 'Freeform' option is used to create the special shape section. Freeform shape tubes can even be created from one of the libraries of Radtube parametric shapes. If none of these standard shapes are suitable, the user simply draws the section center line profile or outside / inside shape using the integrated CAD tools. All modeling in Radtube is done entirely in 3D.

#### Features include

- Intuitive graphical user interface
- Extensive range of CAD interfaces
  - Comprehensive machine and postprocessor database
  - Built-in library of standard tube and aperture types
  - Nesting over single or multiple pipes or sections
- One-click application of toolpath
- Manual application of toolpath for selected areas
- Total control of nozzle angle, both interactively and explicitly
  - Create and apply technology data at any point
  - Inter- and intra-cut collision detection
  - Full solid 3D simulation of machine, nozzle, and part
- Ability to import 3D geometry and machine them directly

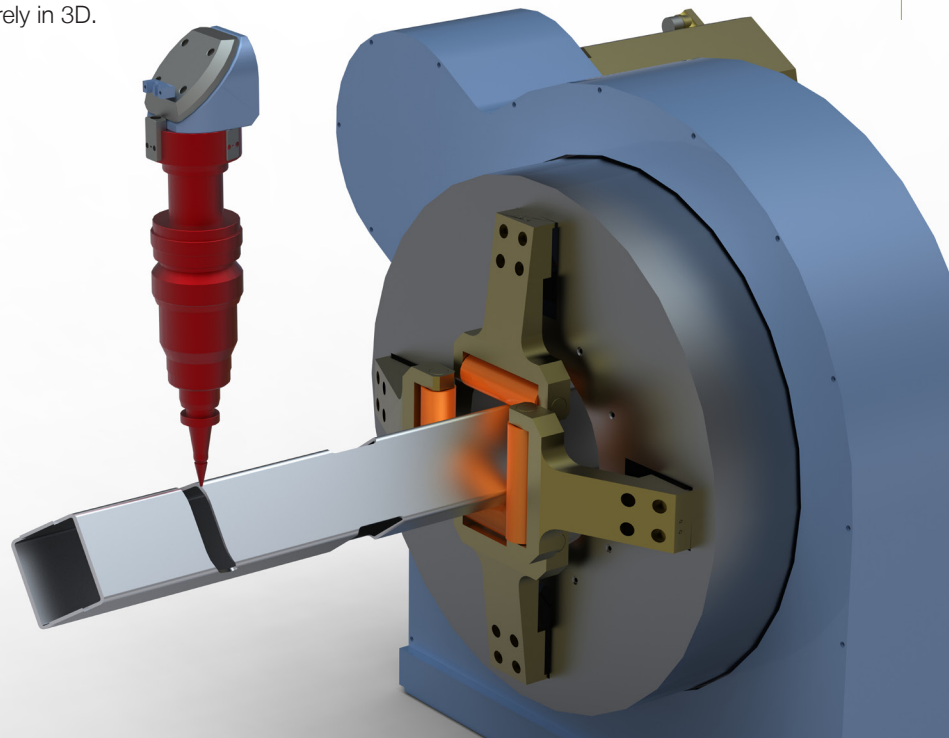

By using Radtube, not only will programming time be minimized, but also the eventual cut-path will be far more efficient, saving further time on the machine. Add in the comprehensive simulation and proofing tools and you have a system that streamlines day-to-day production, reduces costly errors, and eradicates the need for dry-runs.

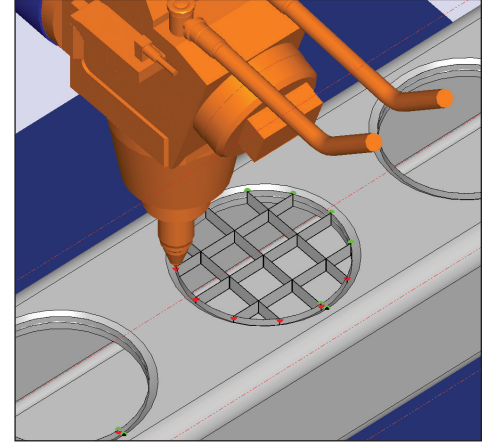
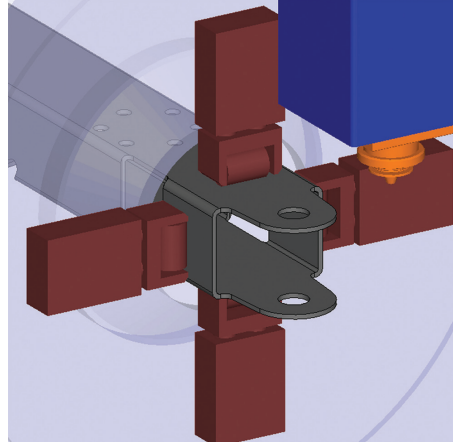
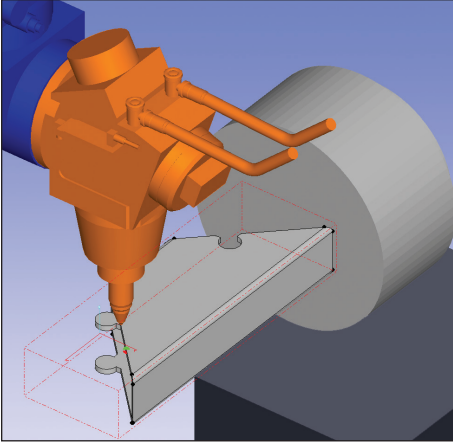

#### Library of Standard Shapes

In a similar way to tube sections, Radtube supplies a library of parametric hole shapes, again with the option to define 'freeform' shapes; so specialized joint features such as duck tails, clips, and key holes are easily added. Holes in the tube are created by generating a solid object to represent the shape, which is then extracted from the tube. The solid can pass through all walls or one wall and can pass through the edge of the section creating a gap.

For holes passing through the tube section at a single or compound angle, positioning can be defined at the mid-point of the section or at a position on the top face. For hole shapes that repeat along the tube in a standard pattern, five pattern shapes are supported: Circle, Line at an Angle, Arc, Square and Grid.

#### Nesting Multiple Parts on a Single Pipe or Section

Where a number of small parts can be produced from a common tube section, it is possible to use the Radtube nesting option. This allows the user to create individual programs for each part (including cutting path), simulate and check the cutting path. Parts of suitable sections are then selected and the quantity required specified. New parts and quantities are added until Radtube reports that the material length specified is full. As each part is selected, Radtube automatically checks the section of the material and reports if it is a suitable part for the nest.

An advanced nesting option is also available which will nest previously machined parts into a multiple number of tubes, where each nested tube can then be postprocessed to form a complete NC program. This advanced nesting functionality provides an easy route to using stock material most effectively and economically.

#### Toolpath Verification and Simulation

Within Radtube the toolpaths are presented showing the angle of the nozzle as it moves around the part in a full solid simulation. Instant feedback is provided about whether or not a specific move is possible - either in terms of machine head movement limits or accessibility. Any collisions that are detected are highlighted both on the model and via on-screen messages.

The toolpath parameters can be edited directly or, in the event of a collision, automatically corrected at any time ensuring that your toolpath is both safe and using the optimum strategy to reduce processing time. Once the toolpath has been optimized, simply select the cutting conditions from the pre-defined technology tables and Radtube quickly generates reliable NC code.

#### Radan

25 North Lake Street  
Suite 220  
Forest Lake, MN  
55025  
U.S.A

tel. (800) 875-7232

email. [radansales@radan.com](mailto:radansales@radan.com)

web. [www.radan.com](http://www.radan.com)

radan

# : radimport

Automated Import and Processing of Geometry Data and Requirement Data

For most sheet working companies the work preparation of parts for nesting is very time consuming. With Radimport, geometry files are automatically converted to tooled Radan parts. With the same mouse click your selection of geometry files can be converted to a nest project.

#### Flexible input

With Radimport you can select multiple DXF or DWG files and add or edit the additional information. Importing files can also be done with a configurable parts list in a CSV format that you might get from an MRP system.

#### Just what is needed

Based on the feature type, layer, line type or color, features can be changed or deleted. You just keep the information that is needed for cutting. At the same time geometry errors can be fixed - like closing profile gaps and removing double lines and arcs. Text information can be transferred to attribute values, for example material, sheet thickness and customer name.

#### Production information

Extra information can be added automatically to the part attributes. You can also engrave the article number, order number or bend line on a laser.

#### Optimum output

After the geometry conversion, parts can be saved as Radan parts or as an optimized clean DXF file. All information such as run time, weight and surface area can be saved as attributes in the part.

#### Nesting

Radimport can create a Radan Nest Project from the parts you have imported. The option is available to edit quantities and other properties of the parts before creating the Nest Project. Radimport can automatically launch the Radan Nester for you to start nesting right away.

#### Product Highlights

Batch import DXF files

CSV lists from MRP

Geometry healing

Properties from DXF or CSV

Split multiple parts in the same drawing

Creates Radan parts

Creates clean geometry DXF files

Send parts to the Radan Nester

CSV log file for MRP feedback

Automatic processing of watched directory

Manual overrides

