

# Diesel Generator set QSK95 series engine

2600 kVA-3750 kVA 50 Hz  
Emissions regulated

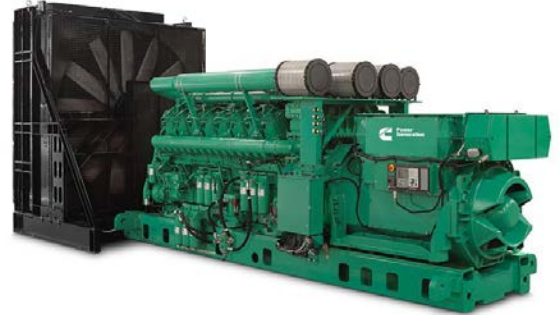

## Description

Cummins Power Generation commercial generator sets are fully integrated power generation systems providing optimum performance, fuel economy, reliability and versatility for stationary standby, prime and continuous power applications.

## Features

**Cummins® heavy-duty engine** - Rugged 4-cycle, industrial diesel delivers reliable power, low emissions and fast response to load changes.

**Alternator** - Several alternator sizes offer selectable motor starting capability with low reactance windings, low waveform distortion with non-linear loads and fault clearing short-circuit capability.

**Control system** - The PowerCommand® digital control is standard equipment and provides total genset system integration including automatic remote starting/stopping, precise frequency and voltage regulation, alarm and status message display, AmpSentry™ protective relay, output metering and auto-shutdown.

**Cooling system** - Standard and enhanced integral set-mounted radiator systems, designed and tested for rated ambient temperatures, simplifies facility design requirements for rejected heat. Also optional remote cooled configuration for non-factory supplied cooling systems.

**Warranty and service** - Backed by a comprehensive warranty and worldwide distributor network.

Model	Standby rating	Prime rating	Continuous rating	Emissions compliance	Data sheets
	50 Hz kVA (kW)	50 Hz kVA (kW)	50 Hz kVA (kW)	EPA and TA Luft	50 Hz
<b>C3500 D5e</b>	3500 (2800)	3125 (2500)	2600 (2080)	2g TA Luft	NAD-5830-EN
<b>C3500 D5e</b>	3500 (2800)	3125 (2500)	2750 (2200)	Tier 2	NAD-5938-EN
<b>C3750 D5e</b>	3750 (3000)	3350 (2680)	3000 (2400)	Tier 2	NAD-5986-EN

Note: All ratings include radiator fan losses.

## Generator set specifications

Governor regulation class	ISO 8528 Part 1 Class G3
Voltage regulation, no load to full load	± 0.5%
Random voltage variation	± 0.5%
Frequency regulation	Isochronous
Random frequency variation	± 0.25%
EMC compatibility	Radiated emissions to BS EN 61000-6.3 Conducted immunity to BS EN 61000-6.2

## Engine specifications

Bore	190 mm (7.48 in)
Stroke	210 mm (8.27 in)
Displacement	95.3 litres (5815 in <sup>3</sup> )
Configuration	Cast iron, V 16 cylinder
Battery capacity	6 x 1400 amps minimum at ambient temperature of -18 °C (0 °F)
Battery charging alternator	140 amps
Starting voltage	24 volt, negative ground
Fuel system	Cummins' Modular Common Rail System
Fuel filter	On engine triple element, 5 micron primary filtration with water separators, 3 micron/2 micron (filter in filter design) secondary filtration
Fuel transfer pump	Electronic variable speed priming and lift pump
Breather	Cummins' impactor breather system
Air cleaner type	Dry replaceable element
Lube oil filter type(s)	Spin-on combination full flow filter and bypass filters
Standard cooling system	High ambient cooling system (ship loose)

## Alternator specifications

Design	Brushless, 4 pole, drip proof, revolving field
Stator	Optimal
Rotor	Two bearing, flexible coupling
Insulation system	Class H on low and medium voltage, Class F on high voltage
Standard temperature rise	125 °C standby / 105 °C prime
Exciter type	Optimal
Phase rotation	A (U), B (V), C (W)
Alternator cooling	Direct drive centrifugal blower fan
AC waveform to total harmonic distortion	< 5% no load to full linear load, < 3% for any single harmonic
Telephone influence factor (TIF)	< 50 per NEMA MG1-22.43
Telephone harmonic factor (THF)	< 3
Anti-condensation heater	1400 watt

## Available voltages

60 Hz line-neutral/line-line	50 Hz line-neutral/line-line			
	• 220/380	• 254/440	• 3464/6000	• 5775/10000
	• 230/400	• 400/690	• 3637/6300	• 6060/10500
	• 240/415	• 1905/3300	• 3810/6600	• 6350/11000

Note: Consult factory for other voltages.

## Generator set options and accessories

### Engine

- 400 V thermostatically controlled coolant heater for ambient above 4.5 °C (40 °F)
- Heavy duty air cleaner
- Redundant fuel filter
- Air starter
- Redundant electric starting
- Eliminator oil filter system
- Lube oil make up

### Alternator

- 80 °C rise
- 105 °C rise
- 125 °C rise
- Differential current transformers

### Cooling system

- Enhanced high ambient cooling system (ship loose)
- Remote cooled configuration

### Control panel

- Multiple language support
- Ground fault indication
- Remote annunciator panel
- Paralleling relay package
- Shutdown alarm relay package

### Generator set

- Battery
- Battery charger
- LV and MV entrance box
- Spring isolators
- Factory witness tests

Note: Some options may not be available on all models - consult factory for availability.

## PowerCommand 3.3 Control System



An integrated microprocessor based generator set control system providing voltage regulation, engine protection, alternator protection, operator interface and isochronous governing. Refer to document S-1570 for more detailed information on the control.

**AmpSentry** – Includes integral AmpSentry protection, which provides a full range of alternator protection functions that are matched to the alternator provided.

**Power management** – Control function provides battery monitoring and testing features and smart starting control system.

**Advanced control methodology** – Three phase sensing, full wave rectified voltage regulation, with a PWM output for stable operation with all load types.

**Communications interface** – Control comes standard with PCCNet and Modbus interface.

**Regulation compliant** – Prototype tested: UL, CSA and CE compliant.

**Service** – InPower™ PC-based service tool available for detailed diagnostics, setup, data logging and fault simulation.

**Easily upgradeable** – PowerCommand controls are designed with common control interfaces.

**Reliable design** – The control system is designed for reliable operation in harsh environment.

**Multi-language support**

### Operator panel features

#### Operator/display functions

- Displays paralleling breaker status
- Provides direct control of the paralleling breaker
- 320 x 240 pixels graphic LED backlight LCD
- Auto, manual, start, stop, fault reset and lamp test/panel lamp switches
- Alpha-numeric display with pushbuttons
- LED lamps indicating genset running, remote start, not in auto, common shutdown, common warning, manual run mode, auto mode and stop

#### Paralleling control functions

- First Start Sensor System selects first genset to close to bus
- Phase Lock Loop Synchronizer with voltage matching
- Sync check relay
- Isochronous kW and kVar load sharing
- Load govern control for utility paralleling
- Extended Paralleling (base load/peak shave) Mode
- Digital power transfer control, for use with a breaker pair to provide open transition, closed transition, ramping closed transition, peaking and base load functions.

#### Other control features

- 150 watt anti-condensation heater
- DC distribution panel
- AC auxiliary distribution panel

#### Alternator data

- Line-to-neutral and line-to-line AC volts
- 3-phase AC current
- Frequency
- kW, kvar, power factor kVA (three phase and total)
- Winding temperature
- Bearing temperature

#### Engine data

- DC voltage
- Engine speed
- Lube oil pressure and temperature
- Coolant temperature
- Comprehensive FAE data (where applicable)

#### Other data

- Genset model data
- Start attempts, starts, running hours, kW hours
- Load profile (operating hours at % load in 5% increments)
- Fault history
- Data logging and fault simulation (requires InPower)
- Air cleaner restriction
- Exhaust temperature in each cylinder

### Standard control functions

#### Digital governing

- Integrated digital electronic isochronous governor
- Temperature dynamic governing

#### Digital voltage regulation

- Integrated digital electronic voltage regulator
- 3-phase, 4-wire line-to-line sensing
- Configurable to require matching

#### AmpSentry AC protection

- AmpSentry protective relay
- Over current and short circuit shutdown
- Over current warning
- Single and three phase fault regulation
- Over and under voltage shutdown
- Over and under frequency shutdown
- Overload warning with alarm contact
- Reverse power and reverse var shutdown
- Field overload shutdown

#### Engine protection

- Battery voltage monitoring, protection and testing
- Overspeed shutdown
- Low oil pressure warning and shutdown
- High coolant temperature warning and shutdown
- Low coolant level warning or shutdown
- Low coolant temperature warning
- Fail to start (overcrank) shutdown
- Fail to crank shutdown
- Cranking lockout
- Sensor failure indication
- Low fuel level warning or shutdown
- Fuel-in-rupture-basin warning or shutdown
- Full authority electronic engine protection

#### Control functions

- Time delay start and cool down
- Real time clock for fault and event time stamping
- Exerciser clock and time of day start/stop
- Data logging
- Cycle cranking
- Load shed
- Configurable inputs and outputs (12)
- Remote emergency stop

#### Options

- Additional configurable inputs and outputs (8)

## Ratings definitions

### Emergency standby power (ESP):

Applicable for supplying power to varying electrical loads for the duration of power interruption of a reliable utility source. Emergency Standby Power (ESP) is in accordance with ISO 8528. Fuel Stop power in accordance with ISO 3046, AS 2789, DIN 6271 and BS 5514.

### Limited-time running power (LTP):

Applicable for supplying power to a constant electrical load for limited hours. Limited Time Running Power (LTP) is in accordance with ISO 8528.

### Prime power (PRP):

Applicable for supplying power to varying electrical loads for unlimited hours. Prime Power (PRP) is in accordance with ISO 8528. Ten percent overload capability is available in accordance with ISO 3046, AS 2789, DIN 6271 and BS 5514.

### Base load (continuous) power (COP):

Applicable for supplying power continuously to a constant electrical load for unlimited hours. Continuous Power (COP) in accordance with ISO 8528, ISO 3046, AS 2789, DIN 6271 and BS 5514.

No sustained overload capability is available at this rating.

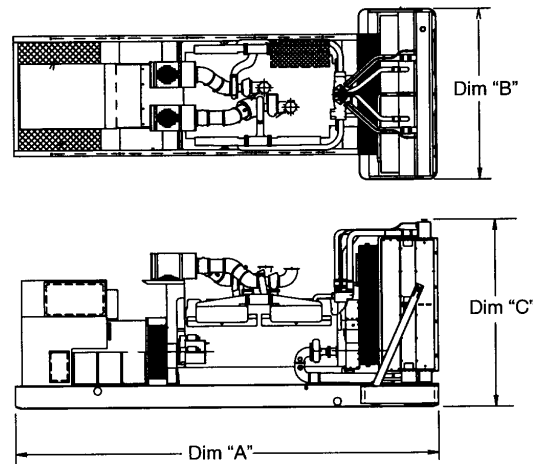

This outline drawing is for reference only. See PowerSuite Library for specific model outline drawing number.

#### Do not use for installation design





Model	Dim "A" <sup>**</sup> mm (in.)	Dim "B" <sup>**</sup> mm (in.)	Dim "C" <sup>**</sup> mm (in.)	Set Weight* dry kg (lbs)	Set Weight* wet kg (lbs)
<b>C3500 D5e</b>	7889 (311)	3028 (119)	3810 (150)	28900 (63800)	30700 (67700)
<b>C3750 D5e</b>	7889 (311)	3028 (119)	3810 (150)	28900 (63800)	30700 (67700)

\* Weights and dimensions represent a set with standard features and alternator frame P80X.

See outline drawings for weights and dimensions of other configurations.

## Codes and standards

Codes or standards compliance may not be available with all model configurations – consult factory for availability.

	This generator set is designed in facilities certified to ISO 9001 and manufactured in facilities certified to ISO 9001 or ISO 9002.		This generator set is available with CE certification.**
	The generator set is available listed to UL 2200, Stationary Engine Generator Assemblies for all 60 Hz low voltage models. The PowerCommand control is Listed to UL 508 - Category NITW7 for U.S. and Canadian usage.**		All models are CSA UL certified to product class 4215-01.**
<b>U.S. EPA</b>	Engine certified to Stationary Emergency U.S. EPA New Source Performance Standards, 40 CFR 60 subpart IIII Tier 2 exhaust emission levels.	<b>ISO8528</b>	This generator set has been designed to comply with ISO8528 regulation.
			The engine used in this generator set complies with TA Luft Standards of 2g/nm <sup>3</sup> (4.8g/bhp-hr) NOx at prime rating corrected to 5% oxygen content and measured in accordance with ISO 8178.

\*\* Regulatory certification pending

### Cummins Power Generation

#### Europe, CIS, Middle East and Africa

Manston Park Columbus Ave.  
Manston, Ramsgate  
Kent CT12 5BF United Kingdom  
Phone 44 1843 255000  
Fax 44 1843 255902

#### Americas

1400 73<sup>rd</sup> Avenue N.E.  
Minneapolis, MN 55432 USA  
Phone 763 574 5000  
Fax 763 574 5298

#### Asia Pacific

10 Toh Guan Road #07-01  
TT International Tradepark  
Singapore 608838  
Phone 65 6417 2388  
Fax 65 6417 2399

**Warning:** Back feed to a utility system can cause electrocution and/or property damage. Do not connect to any building's electrical system except through an approved device or after building main switch is open.

### Our energy working for you.™

©2014 Cummins Power Generation Inc. All rights reserved.

Cummins Power Generation and Cummins are registered trademarks of Cummins Inc. PowerCommand, AmpSentry, InPower and "Our energy working for you." are trademarks of Cummins Power Generation. Other company, product, or service names may be trademarks or service marks of others. Specifications are subject to change without notice.

NAS-5829a-EN (11/14)



[cumminspower.com](http://cumminspower.com)