

Minilase™ XL

laser marking system



TYKMA[™]
ELECTROX

Industrial Laser Systems



Minilase™ XL offers a larger workspace and an open interior for maximum flexibility in a desktop solution. In addition, Minilase™ XL is equipped with our ergonomic features such as the three-side pneumatic vertical door, power focal height adjustment and auto-mode for high volume applications. A service override key and safety warning light allow for open door Class 4 marking capability for larger components.

Minilase™ XL marks all metals, most plastics, carbide, anodized aluminum, painted/coated materials and more. Powerful MOPA fiber laser technology enhances the marking capabilities over basic q-switched fiber laser systems. Selectable pulse durations allow for the processing of a wider variety of materials and substrates.

Our systems save you operating costs in the long run over obsolete and larger scale laser marking systems. Minilase™ XL is air cooled, maintenance-free and includes a comprehensive three year warranty.



Minilase™ XL is equipped with power focal height adjustment controlled through the front mounted operator control pendant. With our easy focus finder system, simply bring the two red aiming beams together on your part and you're in focus and ready to mark. Upgrade to programmable focal height adjustment for automatic focal change between parts.

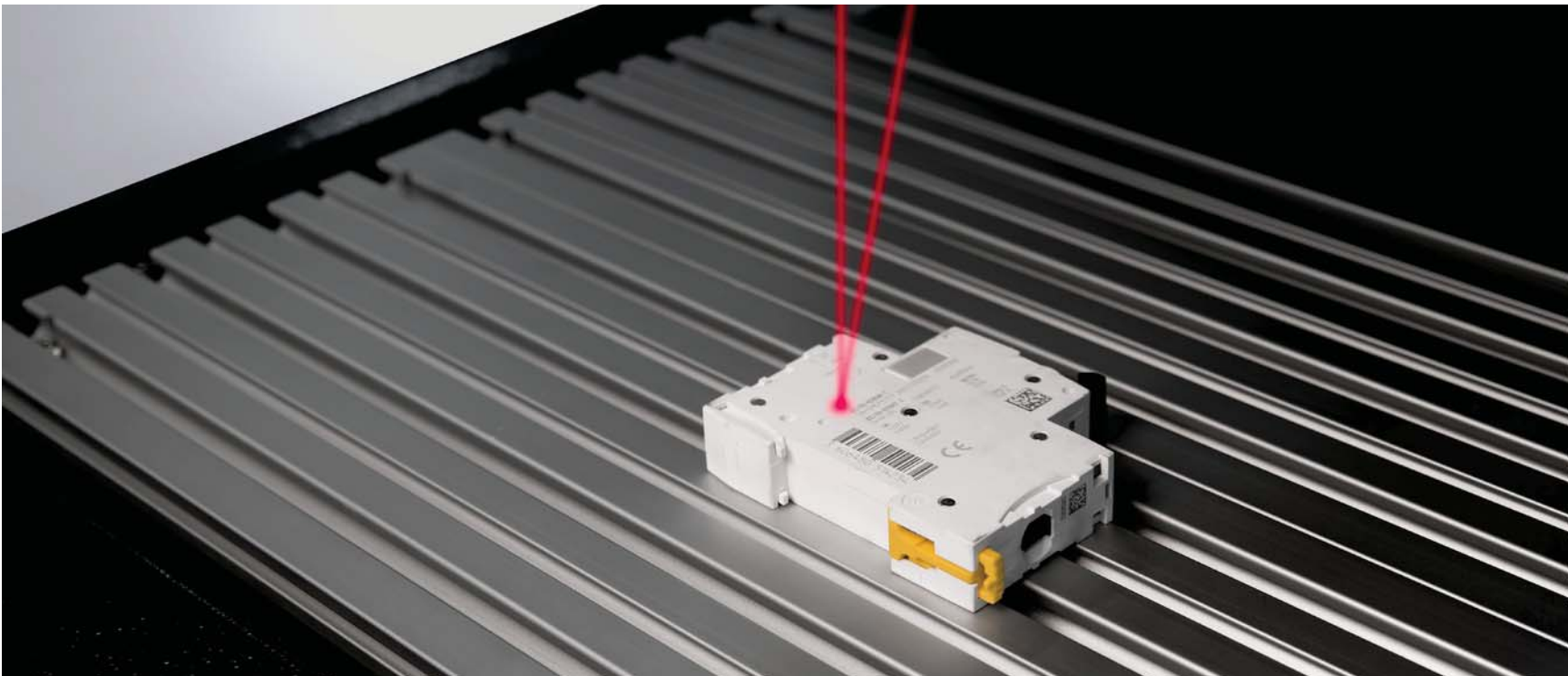



Minilase XL is ideal for high volume applications. A three-side vertical pneumatic door with patented built-in safety provides maximum access to the part loading area. Auto mode allows for the automated sequence of door close, marking and door open, maximizing operator ergonomics.

Minilase XL features an open interior and the most expansive part loading area of our Minilase line. Easily install custom fixtures or utilize a rotary device for 360° radial part marking. Have large or long parts to process? Class 4 capability for open door marking is possible with our service override key, safety warning light and optional laser safety glasses.



Technical Specifications

System Dimensions / Weight (approx.)	24"W x 42.5"L x 33.5"H / 200lbs (mm) 610W x 1,079L x 851H / 91kg
Standard Marking Field	160S (100mm x 100mm) (3.93" x 3.93")
Standard Max Part Size	20"W x 12.5"L x 12.6"H (mm) 508W x 317L x 320H Using rear cabinet space 11"W x 27"L x 12.6"H (mm) 279W x 685L x 320H
Available Marking Lens Upgrade and Marking Field	254S (5.5" x 5.5", 140mm x 140mm)
Maximum Part Height with Lens Upgrade	(254S) 8.6"/220mm
Laser Type	Ytterbium Fiber
Wavelength	1062nm +/- 3nm
Wattage	20W / 50W
Frequency Range	1 - 500kHz
Pulse Duration	Selectable, 260ns or 40ns
Operative Ambient Temperature Range	7° - 36° C / 45° - 97° F
Cooling	Air Cooled
Fiber Cable Length	N/A
Input Power	Power Sensing 110-240VAC 50/60Hz
Aiming Beam	(2) Class IIM Red Diode (635nm)
PC	Laptop/Desktop PC Required
PC Connection	USB
Air Required	60 - 80 psi
Available Ports	Diagnostic
Warranty	36 Month Comprehensive, Unlimited Hours
Documentation (Provided in Digital Format via USB Drive)	System & Software Manuals Laser Settings Guide / Safety Manual Video Tutorials
Included Accessories	Laser Enable Keys (2) / USB Cable Power Cable / USB Drive Class 4 Service Override Key

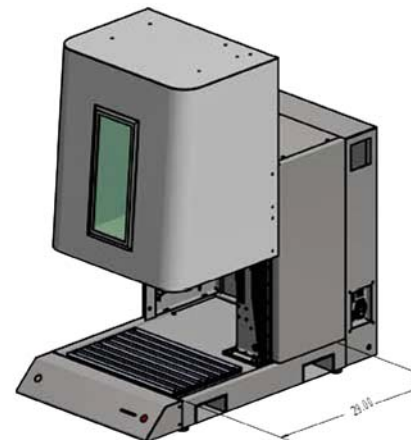
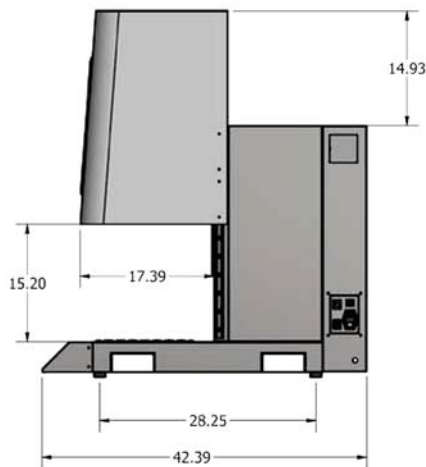
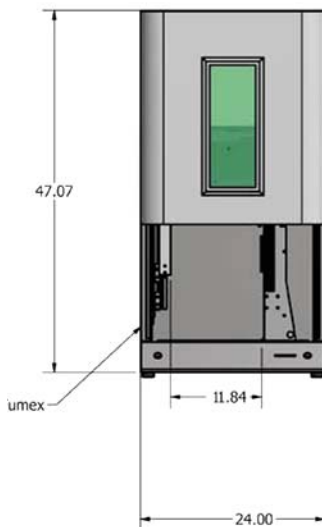

Minilase™ Pro SE Software

With our user friendly software, operators and engineers can quickly create marking files with text, barcodes, 2D codes, and a variety of graphic formats such as DXF, AI, PLT, BMP and JPEG. CAD tools allow users to draw their own graphics and manipulate complex vector files. Automated date coding and serialization capabilities

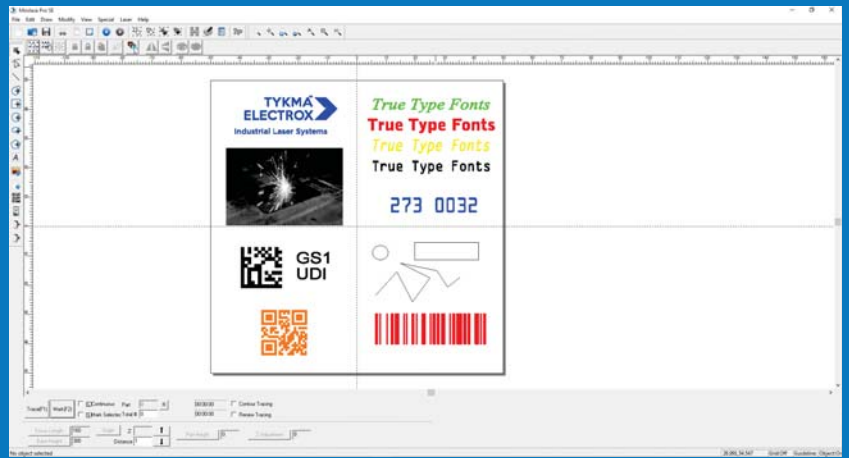

are also included. A pre-configured materials library takes the guess work out of setting up laser marking parameters. Control external axes, focal height adjustment and rotary devices for 360° marking.

Icon Interface, our off-the-shelf runtime solution enables the following: advanced network data retrieval, SQL server connectivity, PLC connectivity, detailed photographic part fixture instructions and displays, operator restrictions and password protections, data entry via barcode scan, and more. When our standard package isn't enough, let TYKMA™ ElectroX create a custom software interface, completely designed to your specifications!

Accessories

- Multi-Waveform laser upgrades
- Rotary devices for 360° radial part marking
- Programmable focal height upgrade
- Fume and dust extraction
- Focal lenses
- Component fixtures
- Laser safety glasses
- And more...





With more than 55 years experience, TYKMA™ ElectroX celebrates a rich history in the development of industrial laser systems with a focus in laser marking, etching, and engraving systems.

With facilities in the U.S.A., U.K., and a global network of distributors, we provide unrivaled industrial laser solutions to customers around the world.

TYKMA™ ElectroX pledges to provide every customer with laser systems of the highest quality and reliability. We're dedicated to providing long-term customer problem resolution and training to ensure your system operates effectively for years to come.

- 24/7, 365 days a year emergency support phone line
- Online remote programming and troubleshooting assistance via Citrix™ secured software
- Application and programming assistance
- Preventive maintenance and critical response agreements
- Loaner and rental laser systems

“The TYKMA Minilase 20W fiber laser has been a great asset for us. We were able to quickly migrate our production from older laser technology to the Minilase. It produces a higher quality mark in less time. We run the machine two shifts per day and it is a key resource in our production process. I wish all of our equipment acquisitions were so productive in such a short time.”

Tom Koenig, Manufacturing Manager, Spyderco

Global Presence

With facilities and distributors in more than 25 countries, TYKMA™ ElectroX is dedicated to providing exceptional service and support to our clients around the world. To learn more about our products and services, visit us online at www.permanentmarking.com.



Follow us on your favorite social media sites!



Industrial Laser Systems

North America, Headquarters

370 Gateway Drive
Chillicothe, OH 45601 • U.S.A.
Phone +1 (740) 779-9918

U.K. Facility

The Nexus Building, Broadway • Letchworth
Hertfordshire SG6 3TA • United Kingdom
Phone +44 (0) 1462 688110

sales@permanentmarking.com

www.permanentmarking.com