



**Manufacturing
more efficiently!**

Professional aid for your machine tool

EXCEPTIONAL PRECISION FROM THE COMPETENCE LEADER!

Increase in productivity requires a minor investment

When every second counts, SCHUNK has the ideal solution for you. You will be surprised: Your machine is smarter than you think! Let your machine handle the workpieces. Clamping and changing processes are becoming more reliable and much faster.

SCHUNK offers the right solution for every task: for tool or workpiece clamping and changing.

Handling



1 GSW-V



2 GSW-B*
with PGN-plus



*also available
with Compensation Unit

3 GSW-B*
with PZN-plus



*also available
with Compensation Unit

Clamping



Changing



Cleaning



4 RGG



Automatic machine operation

Gripper with shaft interface GSW for toolholders



Your added value

- Maximized system productivity via lean automation
- Drive medium in almost every machine as standard
- Minimized investment due to versatility - suitable for many toolholders

Machine self-charging with SCHUNK

The GSW gripper with shaft interface loads and unloads machining centers automatically using its own axis. It can be swapped fast out of the tool rack, just like a normal tool, and moved directly by the machine without requiring a robot or gantry.

A pressure distributor integrated into the adapter plates reduces pressure from the internal coolant feed. This pressurizes the gripper, which is then activated via pistons and wedge hooks. It delivers a continuous supply of cooling lubricant via a side-mounted flow control valve.

Even shorter cycle times are possible when the gripper is activated using compressed air instead of cooling lubricant.



Function cross section

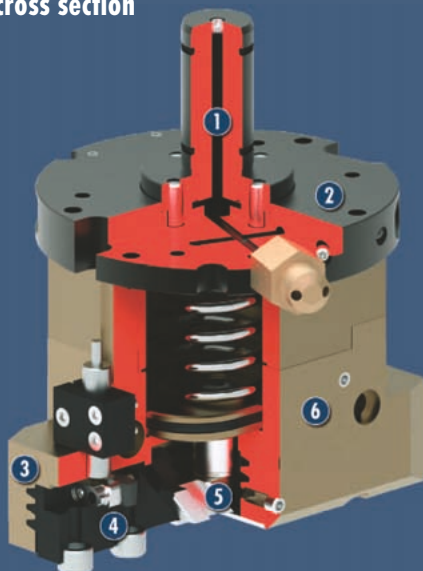

- ① Shaft-Mount
- ② Adapter plate with integrated pressure distributor
- ③ Multiple-tooth guidance
- ④ Base jaws
- ⑤ Kinematics
- ⑥ Housing

Technical Data

Description	GSW	
Clamping diameter	[mm]	20
Gripping force	[N]	70 - 1200
Stroke per finger	[mm]	4 - 10

Handling and preventing the spindle

Gripping with flexible Compensation Unit GSW-AGE

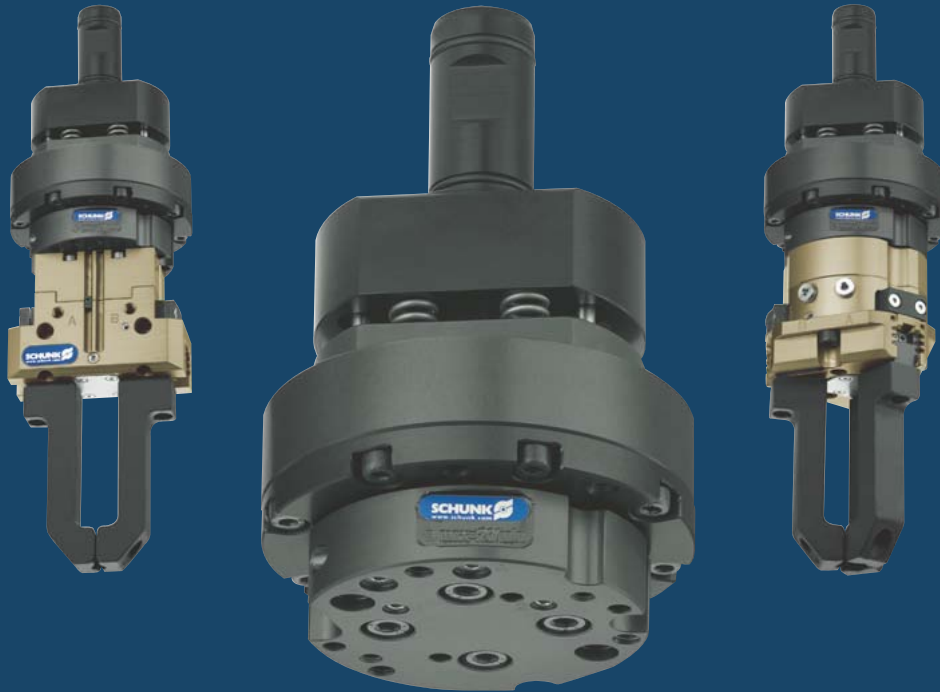

Your added value

- Greater machine service life thanks to lower spindle loading
- Maximized system productivity via lean automation
- Drive medium in almost every machine as standard
- Minimized investment due to versatility – suitable for many toolholders

Avoiding high forces

The connection module GSW-B-AGE is equipped with a gripper interface on one side, and a 20 mm shaft on the other, and can be clamped in many conventional toolholders.

If high forces occur at the spindle or gripper during automated loading, the module GSW-B-AGE adjusts them with a compensation unit. It balances tolerances and inaccuracies in all six degrees of freedom. The unit facilitates the automatic insertion process for workpieces, which are fixed by a bolt or pin. Moreover, the gripper combined with a compensation unit can press a workpiece against a fixed jaw of a clamping force block, until the complete clamping process is finished.

The same gripper can be used flexibly on various machines, independently from the individual spindle interface. It can be driven by coolant or, in order to achieve shorter cycle times, with compressed air, which is fed by the shaft interface of the connection module.

Function cross section

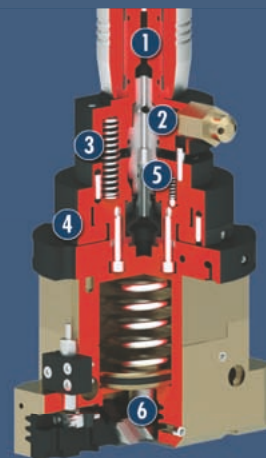

- ① Clamping shank
- ② Adapter plate with integrated pressure distributors
- ③ Axial compensation
- ④ Planar compensation
- ⑤ Angular compensation
- ⑥ Gripper kinematics

Technical Data

Description	GSW-AGE	
Clamping diameter	[mm]	20
Gripping force	[N]	70 - 1200
Stroke per finger	[mm]	4 - 10
Axial compensation	[mm]	3
Radial compensation	[mm]/[°]	±1.5/±3

Gripping under pressure

Vacuum gripper GSW-V solves your time and cost goals



Your added value

- Maximized system productivity via lean automation
- Drive medium in almost every machine as standard
- Vacuum functionality can be implemented without an additional vacuum connection
- Greater productivity, as wear does not result in downtime

Universal handling unit

The new vacuum gripper for spindle interfaces is ideal for handling flat components. It can be used in any machine which provides compressed air or lubricating coolants supply via the toolholder taper. The vacuum gripper is equipped with an integrated Venturi nozzle, and therefore does not require an additional vacuum connection to generate negative pressure.

The gripper applied for patent does not require moving parts, making it maintenance-free. It can therefore be used as a universal instrument for handling a wide range of parts without further adaptations. The only requirement is that the workpiece must have a suction surface which is at least as large as the suction box itself. With a suction cup diameter of 70 mm, workpieces up to 12 kg in weight can be handled with a retaining force of 900 N. Easy and flexible any of the optional suction cups can be fixed at the thread of the interface.

Function cross section



- ① Vacuum suction cup for a flexible range of parts
- ② Intake duct for producing suction power
- ③ Introduction of medium via spindle interface
- ④ Venturi nozzle for producing negative pressure
- ⑤ Outlet opening for diverting the negative pressure

Technical Data

Description	GSW-V	
Clamping diameter	[mm]	20/25/32
Gripping force	[N]	20 - 3000

In perfect order

Cleaning Unit RGG for your machine room



Your added value

- Automatic cleaning unit
- Operation with compressed air or coolant
- Reduce non-productive times
- Increases safety for the operator

Machine table that is in perfect working order

Not only loading but also automatic cleaning of the workspace can be done by the machine. SCHUNK has developed a special cleaning unit for this purpose, which also fits into the tool mounting with a diameter of 20 mm.

A short control program is enough to quickly clean the workpiece space for inspecting every corner and niche, and to clean the tables and clamping devices from chips. Compared to manual cleaning by the operator, the cleaning work is carried out faster and is more systematic when done by the machine.

Function cross section

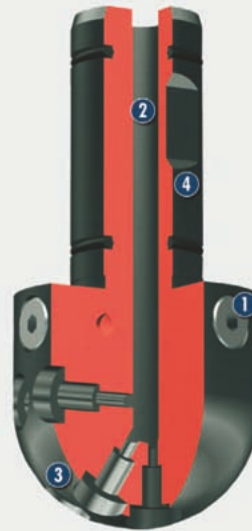

- ① Locking screws and throttle inserts for changing the cleaning jet
- ② Center hole, for supply of the cleaning medium
- ③ Outlets for generating the cleaning jets
- ④ Clamping diam

Technical Data

Description	RGG	
Clamping diameter	[mm]	20
Weight	[kg]	0.1

Copy fax reply, complete and fax to +49-7133-103-2189

Please contact me

for a consultation by phone

for a personal consultation from the SCHUNK area sales manager

Company

Name

Department

Street

ZIP

City

Phone

Fax

E-mail