

SC202 / SC203

Features and Strengths

- Highly operational reliability despite fluctuating or low compressed-air pressure
- Integrated check valve on vacuum release port
 - Quick evacuation time
- Compact size and light weight



Specifications

Description	SC202	SC203
Max. Vacuum level	-91 kPa	-93 kPa
Open Vacuum flow	44 NI/min	84.5 NI/min
Max. Feed pressure	7 bar	7 bar
Temperature	-20 ~ 80 °C	-20 ~ 80 °C
Noise level	59 ~ 65 dbA	59 ~ 65 dbA
Weight	80g	85g

Vacuum Flow

Model	Max. vacuum (-kPa)	Feed Pressure (bar)	Vacuum flow (NI/min) at different vacuum levels (-kPa)									
			0	10	20	30	40	50	60	70	80	90
SC202	48	1.7	38.5	20	16	12	5.3					
	65	2.2	39	26.5	17.3	15.6	13.5	8.4	2.6			
	91	3.14	44	36	24.5	16.5	16	13.8	10	7	3.5	
	89	4.0	42	38.8	28.5	21.2	15.8	12.2	9.5	7	2.4	
SC203	49	1.7	55	23.2	15.5	12.6	6.1					
	65	2.2	68	31	16.5	15.5	13.8	9	3.5			
	93	3.14	84	37.5	26	16	15.2	12.3	10	7.2	4	
	91	4.0	84.5	40	33.2	22.6	15.8	12	9.2	7.3	2.9	

Evacuation Time

Model	Feed Pressure (bar)	Air Consumption (NI/min)	Evacuation time in sec / liter to reach different vacuum levels (-kPa)									
			10	20	30	40	50	60	70	80	90	
SC202	1.7	22	0.33	0.47	0.89	1.93						
	2.2	25.5	0.20	0.47	0.70	0.92	1.24	1.35				
	3.14	34	0.15	0.39	0.95	1.03	1.28	1.32	2.12	3.54		
	4.0	40.5	0.15	0.42	0.56	0.80	0.99	1.21	1.46	3.74		
SC203	1.7	21	0.13	0.40	0.79	1.57						
	2.2	24.5	0.08	0.39	0.59	0.85	1.10	0.96				
	3.14	33	0.06	0.28	0.51	1.01	1.18	1.29	1.73	3.00		
	4.0	40	0.08	0.24	0.50	0.71	0.85	1.18	1.41	3.05		

Dimensions – SC202P-C

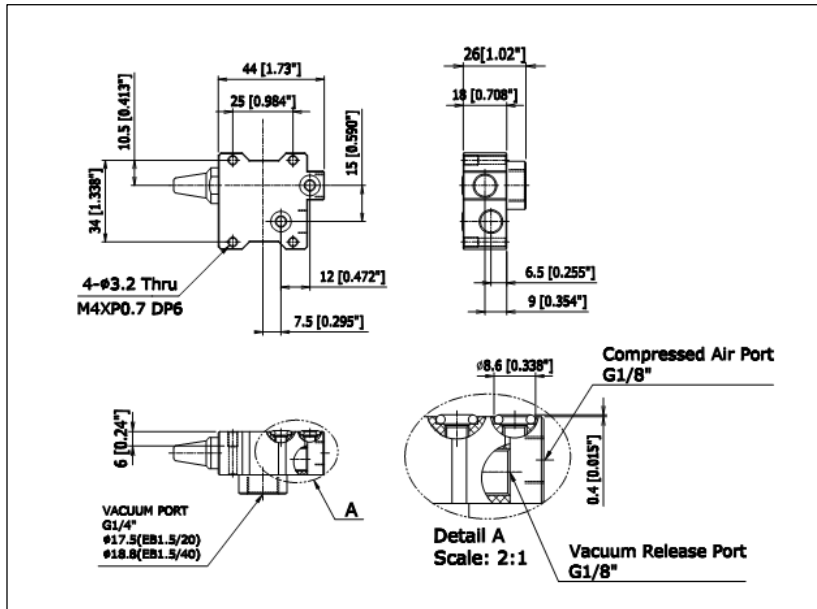

[Unit : mm]

Dimensions – SC203P-C

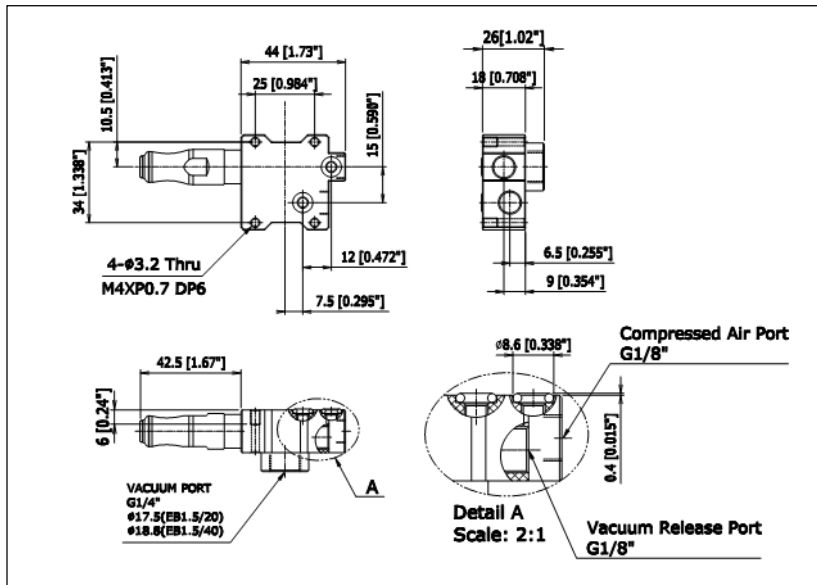

[Unit : mm]

Build an Ordering No.



1. Basic pump	Description	Ordering No.
	SC pump, 2-stage cartridge, Plug	SC202P-C
	SC pump, 3-stage cartridge, Plug	SC203P-C

2. Vacuum port	Description	Ordering No.
	Vacuum port, G1/4" female	14F

Spare Parts – Basic pumps

Model	Description	Weight (g)
SC202P-C	SC pump, 2-stage cartridge, Plug	80
SC203P-C	SC pump, 3-stage cartridge, Plug	85

Spare Parts – Plugs

Model	Description
VCP202PS2	Holding plug for SC202P-C
VCP203PS2	Holding plug for SC203P-C