

**NEXUS 610RS/RSB**



# NEXUS 610RS/RSB Rockwell/Brinell hardness tester

Load cell, closed loop, force feedback system, no weights, eliminates wrong tester setting and force overshoot

Specimen lighting with adjustable illumination levels

Adjustable workpiece clamping attachment, indenter protection

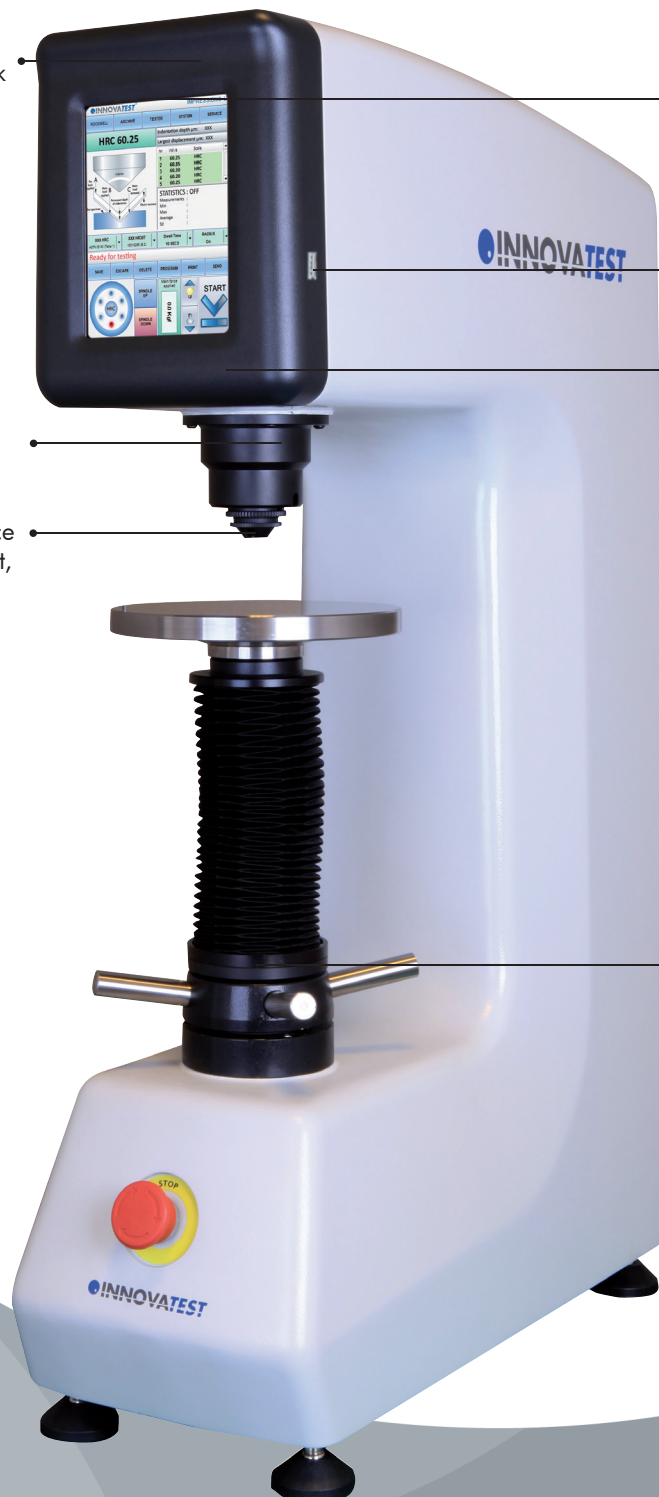

6.5", Full color industrial LCD touch screen for easy tester operation, can also be operated by wireless mouse and keyboard

Front panel USB connector for USB stick or harddisk

High performance micro PC, Windows Embedded operating system, SSD drive

IMPRESSIONS LT™ advanced hardness testing software, includes file storage, test program storage, machine settings storage, report generator, etc.

Update and upgrade service via internet connection

Precision elevator spindle allows large workpiece accommodation (vertical capacity 250mm, horizontal capacity 170mm)

Connectivity USB (3x), RJ45-LAN, W-LAN (optional), Wi-Fi onboard (Optional), Bluetooth (Optional)

# General information

The NEXUS 610 series are a new generation of hardness testing instruments. The testers main body is a fine casted rigid structure which incorporates a load cell, closed loop force actuator that provides continuous force feedback information to the advanced electronics set.

The system avoids "overshoot" during the test force application and guarantees the one of the best GR & R results ever seen on Rockwell/Brinell hardness testers in this class. The tester meets or exceeds the ISO, ASTM and JIS standards. (ISO 6508, ISO 2039/2, ASTM E18, ASTM B254, JIS Z2245)

Test forces range from 2.5kgf/24.5N to 150kgf/1471N, Advanced algorithms, digital filter technology and state of the art electronics provide a very reliable and robust Rockwell hardness tester.

The test cycle can be as little as 15 seconds (at a dwell time of 10 seconds).

NEXUS stands for Next Generation.

The 610RS model allows to perform hardness tests in all Rockwell and Superficial Rockwell scales.

The 610RSB model adds the Brinell scales between 2.5kgf/24.5N to 187.5kgf/1838N additional to the Rockwell and Superficial Rockwell scales.

Models **RSB** are supplied with a separate Brinell measuring microscope which offers Brinell optical testing up to 187.5kgf/1838N. After keying in the indent diameter, hardness values are instantly displayed on the LCD screen.

## Features

- Load cell, force feedback, closed loop system
- High performance embedded fanless micro PC
- MS Windows embedded operating system
- Excellent accuracy
- Unmatched GR & R results in its class
- Load range 2.5kgf/24.5N up to 187.5kgf/1838N (depending on model)
- Fully automatic operation
- Meets or exceeds ISO, ASTM and JIS standards
- Shape correction settings for curved surfaces
- Go/No Go function with visual and acoustic warning
- Large memory for measurements with statistic results
- Easy calibration function
- Testing program storage
- Testing value storage
- Standard workpiece clamping attachment
- Printer & USB (3x), RJ45-LAN, W-LAN (optional), Wi-Fi onboard (Optional), Bluetooth (Optional) output
- Wireless mouse and keyboard
- External Brinell microscope (RSB model)
- Large workpiece accommodation
- Firmware service over internet "INNOVATEST Team Viewer" pre-installed

# Technical specifications

NEXUS 610RS/RSB	
Hardness scales RS	Rockwell and Superficial Rockwell all scales
Hardness scales RSB	Rockwell and Superficial Rockwell and all Brinell scales (2.5kgf/24.5N to 187.5kgf/1838N)
Load application	Load cell, force feedback, closed loop system
Rockwell Pre load	3kgf and 10kgf
Rockwell main load	15kgf, 30kgf, 45kgf, 60kgf, 100kgf, 150kgf
Rockwell test scales	A, B, C, D, E, F, G, H, K, L, M, P, R, S, V
Superficial Rockwell scales	15N, 30N, 45N, 15T, 30T, 45T, 15W, 30W, 45W, 15X, 30X, 45X, 15Y, 30Y, 45Y
Brinell test load (RSB model)	2.5kgf/24.5N to 187.5kgf/1838N
Brinell test scales (RSB model)	HB1: 2.5kgf/24.5N, 5kgf/49N, 10kgf/98N, 30kgf/295N HB 2.5: 6.25kgf/61.29N, 15.625kgf/153.2N, 31.25kgf/306.45N, 62.5kgf/612N, 187.5kgf/1838N HB5: 25kgf/245.16N, 62.5kgf/612N, 125kgf/1225N HB10: 100kgf/980.7N
Operating system	MS Windows® Embedded , INNOVATEST IMPRESSIONS LT, 32Gb SSD harddrive for data storage
Display	6.5" full color industrial touch screen, testing results, statistics, can also be operated by mouse and keyboard
Display overview	Conversion to other hardness scales such as Brinell, Vickers, Leeb, UTM. convex, concave adjustment, machine settings, calibration
Standards	Meets or exceeds ISO, ASTM, JIS standards
Test cycles	Motorized, fully automatic, Pre load, Load, Dwell, Unload process
Indentors	Rockwell Diamond Cone: 120° Rockwell balls: 1/16", 1/8", 1/4", 1/2" Brinell Balls: 1mm, 2.5mm, 5mm, 10mm
Dwell time	Pre-load 1-99 seconds, Main load 1-99 seconds, Recovery 1-99 seconds
Connectivity	USB-2 (3x), converter to RS-232, LAN RJ45, WLAN (Optional), Wi-Fi onboard (Optional), Bluetooth (Optional)
Service connection	Firmware service over internet "INNOVATEST Team Viewer" pre-installed
Printer	Any MS Windows® supported printer
Optical system RSB	Brinell microscope
Workpiece accommodation	Vertical capacity 250mm Horizontal capacity 170mm (from indenter center-line)
Operating temperature	10°C to 35°C, non-condensing
Machine dimensions	220mm x 540mm x 855mm (WxDxH)
Machine weight	100kg
Power supply	100V AC to 240V AC, 50Hz/60Hz, single phase

## Standard delivery

- V-anvil
- Flat anvil 60mm
- Round testing table 150mm
- Brinell microscope (RSB)
- Power cable
- Four adjustable feet
- INNOVATEST® certificate
- Installation and user manual
- Pre-installed (plug and play)

## Optional accessories

- Certified indentors (ASTM, DIN, ISO)
- Certified reference hardness blocks (ASTM, DIN, ISO)
- Custom testing tables
- Precision vice for small parts, jaw width 36mm
- Precision vice for small parts, jaw width 42mm
- Precision vice for small parts, jaw width 75mm
- Wireless mouse and keyboard
- V-blocks and special clamps
- Manual X-Y stage 100mm x 60mm, micrometer travel 25mm x 25 mm
- Solid tester table and storage cabinet



## Order details

### NEXUS 610RS

Rockwell, Superficial Rockwell all scales  
test forces 3kgf/29.4N to 150kgf/1471N

### NEXUS 610RSB

Rockwell, Superficial Rockwell, Brinell all scales  
test forces 2.5kgf/24.5N to 187.5kgf/1838N (for Brinell)

# Technical drawing NEXUS 610RS/RSB

All dimensions are in mm

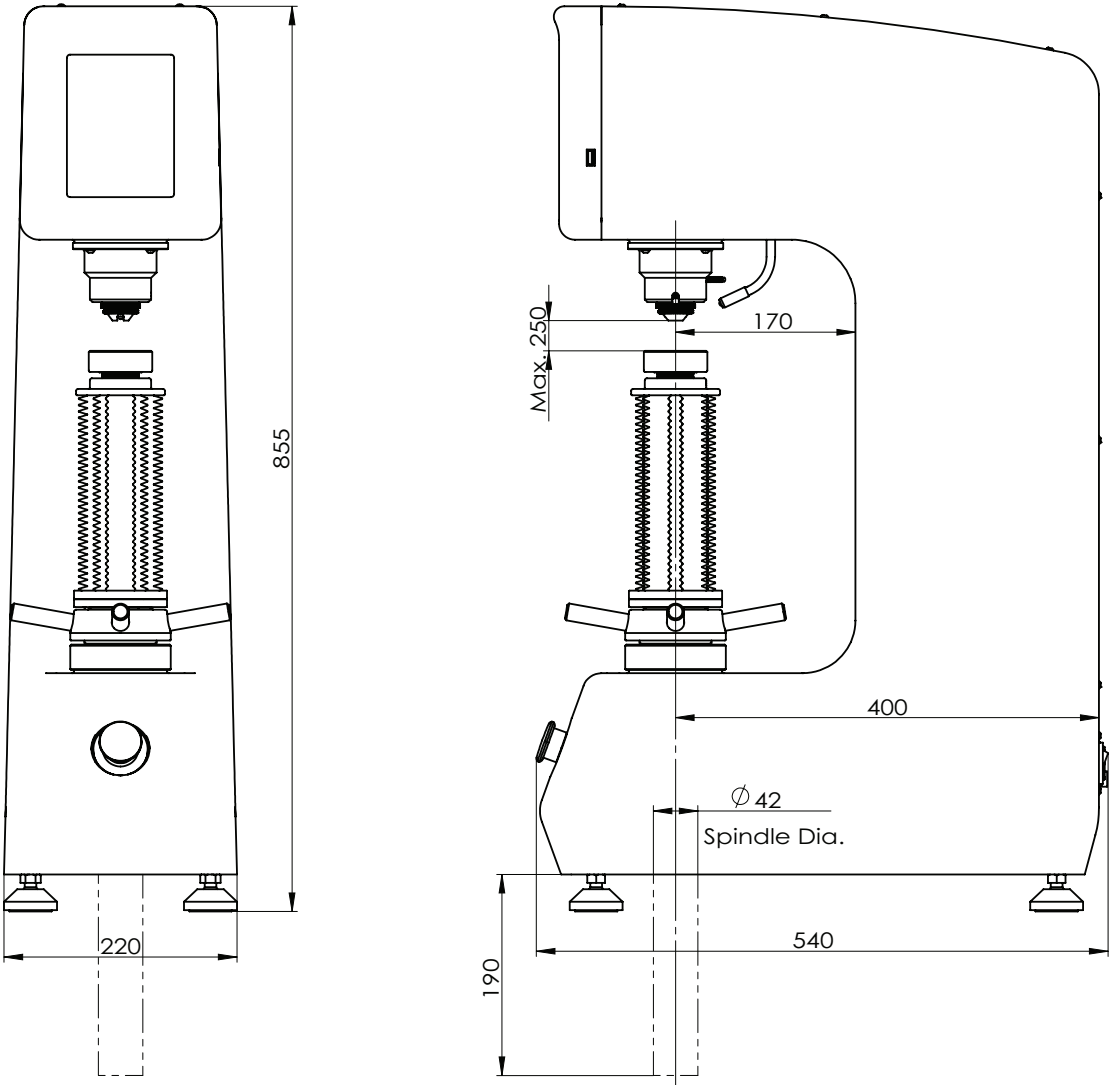

All dimensions are in mm

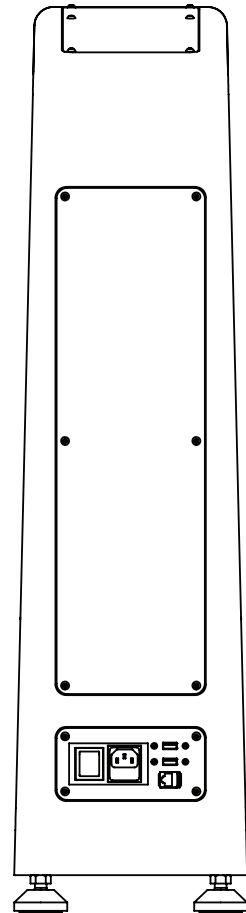
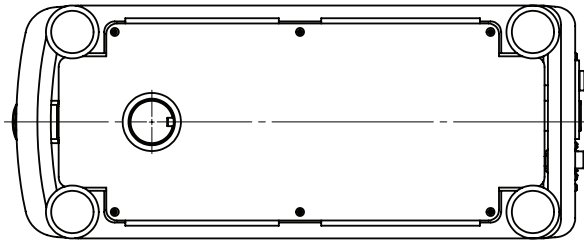

Represented by:

IN13-016 050615

## CORPORATE HEAD OFFICE

### **INNOVATEST Europe BV** **MANUFACTURING, DISTRIBUTION & SERVICE**

Borgharenweg 140  
6222 AA Maastricht (The Netherlands)  
Phone: +31 43 3520060  
Fax: +31 43 3631168  
E-mail: [info@innovatest-europe.com](mailto:info@innovatest-europe.com)  
Website: [www.innovatest-europe.com](http://www.innovatest-europe.com)

---

## BRANCHE OFFICES

### **INNOVATEST Benelux BVBA** **SALES & SERVICE**

Phone: +32 12 779002  
Fax: +32 12 779003  
E-mail: [info@innovatest-benelux.com](mailto:info@innovatest-benelux.com)  
Website: [www.innovatest-europe.com](http://www.innovatest-europe.com)

### **INNOVATEST Shanghai Co., Ltd.** **ASIA & CHINA SALES & SERVICE**

Building 2, No.123, 1165 Nong Jindu Road,  
South Metropolis Industrial Park  
Minhang District, Shanghai, P.R. China  
Zip code: 201108  
E-mail: [info@innovatest-shanghai.com](mailto:info@innovatest-shanghai.com)  
Website: [www.innovatest-shanghai.com](http://www.innovatest-shanghai.com)

Changes in products and/or product specifications can emerge due to new technologies and continuous development.

We reserve the right to change or modify specifications of products without prior notice.

We recommend you to contact our sales office for up-to-date information.

© All rights reserved