

SCHRÖDER
GROUP



MOTORIZED SHEAR
PDC / PDC-NC

PDC – Options for every cutting task

The power-operated shear PDC is a stronger version of the MHSU line and offers a higher performance thanks to its robust design and its belateral „DUO-CUT,“-drive.



Motorized shear PDC



Motorized shear PDC -NC

Standard – Type PDC

The power-operated shear PDC has been designed for processing sheet metal and plastics.

It is a stronger version of the MHSU line. The sturdier and stiffened table and frame design as well as the „Duo-Cut“ drive with two motors make for a considerably improved cutting capacity while retaining the many functional merits of the MHSU.

With the aid of new design techniques, we are able to offer a tried and tested product incorporating state-of-the-art technology.

Extension – Type PDC-NC

The motorized guillotine type PDC-NC is technically based on the PDC. With an integrated NC positioning gauge and a pneumatically controlled sheet support the PDC-NC offers an extensive standard equipment and an attractive design that all together lead to a significant upgrade compared to the PDC.

What you get here is top technology and top design that fully meet your high demands.



Standard equipment

PDC	PDC-NC
Manual back gauge 750 mm	NC positioning gauge POS 100 with 9-step program, 6 - 750 m
	Cut counter
Hold-down device with hard rubber rail to protect polished sheets	
Manual blade gap adjustment, two-sided	
Extended angle gauge, right, with T-slot and scale 1,000 mm	
2 sheet support arms with T-slot and scale 1,000 mm (3 support arms with a working length of 4,000 mm)	
Table with exchangeable stainless steel plates with recessed grips	
All-steel blade, double-edged	
Selector switch for single and continuous stroke	
From 2,000 mm bilateral drive	
	Pneumatically controlled sheet support to the front with sheet separator max. 750 mm, optionally to the back without sheet separator
	Obligatory CE safety package
Foot switch	
Anchor plates incl. dowels	

Special equipment

	PDC	PDC-NC
Safety	Obligatory CE safety package for standard machines: rear guarding via 2-beam light barrier incl. side protection grid (no longer required with ordering sheet support and/or motorized gauge option)	Included in standard equipment
Blades	Blades designed for stainless steel, instead of standard blades	
Others	<ul style="list-style-type: none"> - Cutting edge illumination LED - Pneumatic hold-down device - Stroke counter (with POS 100 incl.) - Sheet stacking cart, for front or back - Sheet support see p. 7 under gauges 	
Gauges	see p. 7	
Tables	see p. 7	

The right accessories for all tasks

The Schröder shear is already a productivity gain in its standard equipment. Thanks to its numerous options this machine can be used for many businesses.

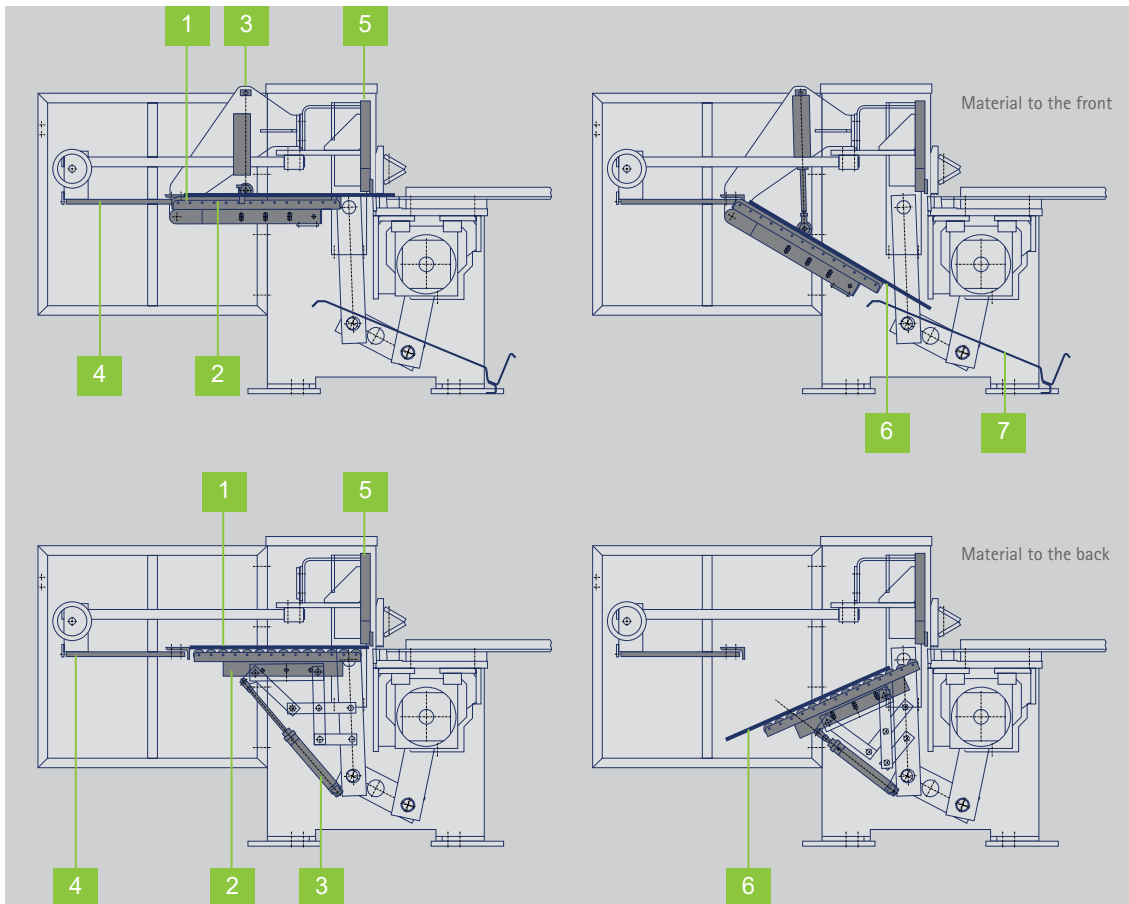

Table with exchangeable stainless steel plates with recessed grips [8] and extended angle gauge on the right with scale incl. lateral flip gauge on linear guide [9]

Technical description of the sheet support system

- 1 Cutting material
- 2 Tilting depositing device
- 3 Cylinder
- 4 Gauge
- 5 Cutting beam
- 6 Blank
- 7 Sheet separator

High rigidity already in its basic configuration

The motorized shear PDC is based on a torsion-free rigid welded construction and a „Duo-Cut“ drive with two powerful dynamic low-noise geared motors. The high static and dynamic rigidity are guaranteed thanks to sturdy key components such as cutting beam, sheet support table, lateral frames and main drive units.

The generously designed flat cutting beam guides dispose of robust and wear-resistant special sliding covers. This maintenance free sliding cover ensures optimum guidance and damping characteristics.

Gauge options for better handling

Both the PDC and the PDC-NC are able to process various types of sheets. We supply you with gauge options that are suited to your individual requirements.

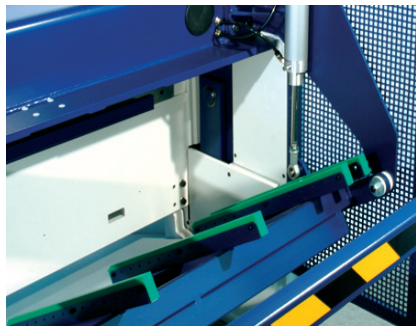

Sheet support to the front, pneumatically controlled, incl. sheet shute 750 mm or rather 1,000 mm



NC positioning gauge POS 100 with 9-step program 750 mm or optionally 1,000 mm



Manual back gauge

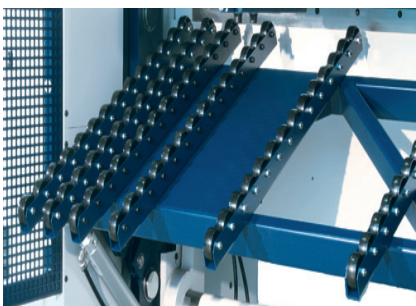

Optional: Sheet support to the back, pneumatically controlled, for gauge extension up to 1,000 mm, supporting width 750 mm

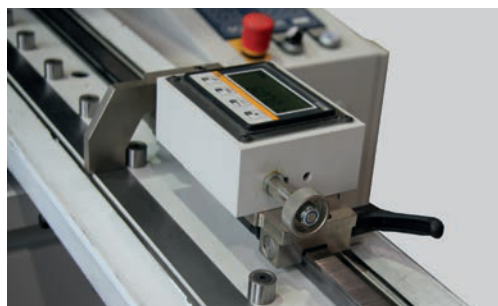

Optional for PDC and PDC-NC: Extended angle gauge (right or left) with electronic length measurement system incl. lateral flip gauge on linear guide



Optional: Manual back gauge, adjustable from the front, with digital readout

Efficient sheet support

The sheet support holds the sheet upwards and leads the sheet in horizontal position to the gauge. After a successful cut the sheet will be deposited to the back or to the front.

Software control POS 100

The back gauge is contained in the standard configuration and can be adjusted manually. Its modern, low-friction and almost wear-free crank drive assures high cutting capacities with minimum effort. Optionally, the operator can acquire the software POS 100.

This software enables a motorized adjustment of the back gauge and thus accelerates the operation process. It has a 9-step program that is able to control gauge lengths up to 750 mm or 1,000 mm and significantly facilitates the handling and precise positioning compared to the manual adjustment.

Exact positioning

In order to be able to position a sheet exactly right-angled, it is recommended to make use of an extended angle gauge. Big sheets can be processed even better and more efficiently.

As an extra feature the extended angle gauge is also available with an electronic length measurement system.

Dimensions and technical data PDC / PDC-NC

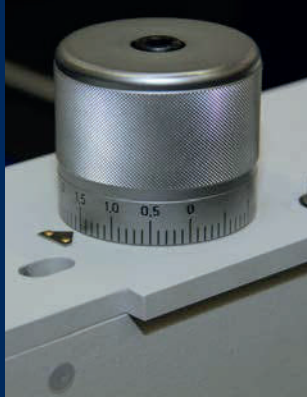

Standard:
Manual blade gap adjustment,
two-sided

PDC	1,000 x 4.5	1,500 x 4.5	2,000 x 4.0	2,500 x 3.5	3,200 x 3.0	4,000 x 2.5
Working length (a)	1,030 mm	1,530 mm	2,030 mm	2,530 mm	3,230 mm	4,080 mm
Sheet thickness (400 N/mm ²)	4.5 mm	4.5 mm	4.0 mm	3.5 mm	3.0 mm	2.5 mm
Cutting angle	3.0°	2.86°	2.5°	2.0°	1.6°	1.3°
Number of strokes (per min.)	34					
Driving power	1 x 5.5 kW	1 x 7.5 kW	2 x 4.0 kW			
Weight (ca.)	2,100 kg	2,450 kg	2,860 kg	3,110 kg	3,560 kg	4,160 kg
Outer dimensions						
Machine height (b)	1,400 mm					
Hole spacing of machine fixings (c)	1,470 mm	1,970 mm	2,470 mm	2,970 mm	3,670 mm	4,520 mm
Maschine length (d)	1,340 mm	1,840 mm	2,340 mm	2,840 mm	3,540 mm	4,390 mm
Back gauge, manual 750 mm D	2,070 mm					
Back gauge, manual 1,000 mm D	2,140 mm					
Back gauge, motorized 750 mm D	2,070 mm					
Back gauge, motorized 1,000 mm D	2,100 mm					

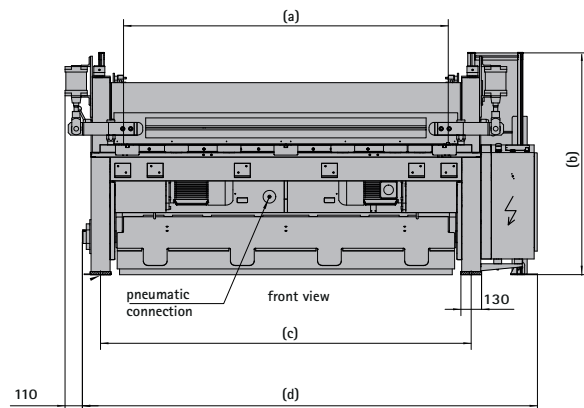

with pneumatic
hold-down device

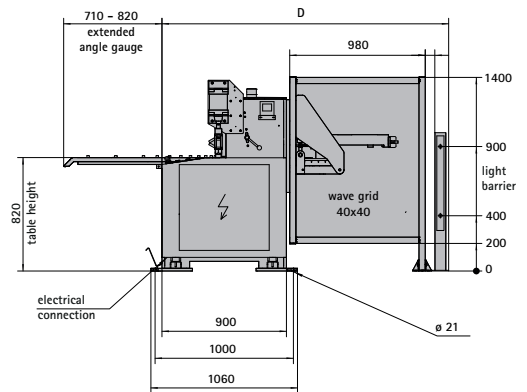

PDC-NC	3,200 x 3.0	4,000 x 2.5
Working length (a)	3,230 mm	4,080 mm
Sheet thickness 400 N/mm ²	3.0 mm	2.5 mm
Cutting angle (°)	1.6	1.3
Number of strokes (per min.)	34	
Drive power (kW)	2 x 4.0 kW	
Weight	3,500 kg	3,800 kg
Outer dimensions		
Machine height (b)	1,452 mm	
Hole spacing of machine fixings (c)	3,540 mm	4,520 mm
Machine length (d)	4,270 mm	5,120 mm
Machine width	2,869 mm	2,869 mm

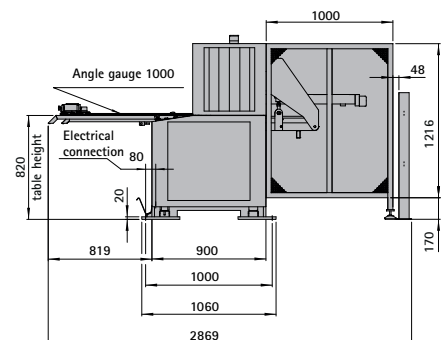
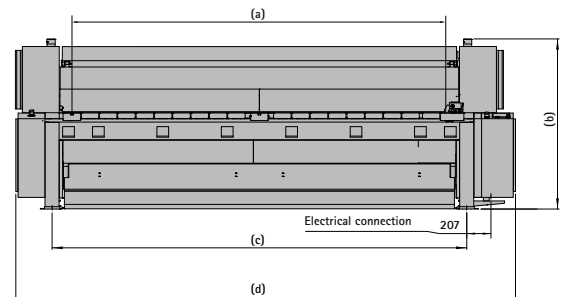

All specifications are considered as guidelines and may be subject to changes at any time.

Gauges and table variants

Special equipment

	PDC	PDC-NC
Gauges	Manual back gauge 1,000 mm	
	Manual back gauge 750 mm, adjustable from the front, with digital readout	
	NC positioning gauge POS 100 with 9-step program 750 mm/1,000 mm	NC positioning gauge POS 100 with 9-step program 1,000 mm
	Sheet support to the front, pneumatically controlled, incl. sheet shute max. 750 mm	Included in standard equipment
	Sheet support to the front, for gauge extension max. 1000 mm	
	Sheet support to the back, pneumatically controlled, for gauge extension max. 1000 mm, incl. supporting width max. 750 mm	
Tables	Sheet support arm with T-slot and scale - 1,500 mm - 2,000 mm incl. foot rest	
	Extended angle gauge (right or left) with T-slot and scale - 1,500 mm - 2,000 mm incl. foot rest	
	Extended angle gauge (right or left) with scale incl. lateral flip gauge on linear guide - 1,000 mm - 1,500 mm - 2,000 mm incl. foot rest	
	Extended angle gauge (right or left) with electronic length measurement system, fine adjustment and lateral flip gauge on linear guide - 1,000 mm - 1,500 mm - 2,000 mm incl. foot rest	
	Adjustable angle gauge with scale division 0 - 180°	
	Tipping gauge for insertion in T-slot	
	Linear guide at the front for movable table support arms (without support arms)	
	Moveable support arm for linear guide, at the front, incl. T-slot and scale - 1,000 mm - 1,500 mm - 2,000 mm incl. movable foot rest	
	Support plates for closed table	
	Closed table, support plates and support arms with ball rollers	



Schröder Group

The Schröder Group consists of Hans Schröder Maschinenbau GmbH, which is located in Wessobrunn, Germany, and SCHRÖDER-FASTI Technologie GmbH, which is located in Wermelskirchen, Germany.

Founded in 1949, Hans Schröder Maschinenbau GmbH unifies traditional and modern approaches in machine building: Successfully managed as a quality and customer-oriented, family-owned company, Hans Schröder Maschinenbau is specialized in the development of modern machine concepts for bending and cutting sheet metal.

The successful integration of the Fasti Company in 2006 and its worldwide presence make the Schröder Group one of today's leading providers of machines for bending, cutting, beading, flanging, and circular bending all types of sheet metal. The company's precision machines range from proven solutions for craftsmen to innovative, high-performance machines for automatic industrial production processes. Overall, the Schröder Group currently employs more than 240 people at various locations at home and abroad.

All information provided as a guide only
and subject to change at all times..
HSM 151006EN

Schröder Maschinenbau GmbH
Feuchten 2 | 82405 Wessobrunn-Forst | Germany
T +49 8809 9220-0 | F +49 8809 9220-700
E info@schroedergroup.eu
www.schroedergroup.eu

SCHRÖDER
GROUP