



Pilous

Železná 9, 619 00 Brno, Czech Republic

Tel.: +420 543 25 20 10

e-mail: wood@pilous.cz, www.pilous.cz

CTR 750 E



4140 x 34 x 0,9 – 1,1

Max. log diameter	750 mm
Max. opening between blade guides	640 mm
Max. elevation of blade	660 mm
Min. log height	25 mm
Max. depth of cut	255 mm
Max. log length (standard model)	3,45 m
Length track section	2,25 m
Min. log length	0,75 m
Saw blade motor	5,5 kW
Horizontal feed motor	0,18 kW
Max. feed speed (forw/back)	15 m/min.
Sawblade	4140 x 34 x 1,1 mm
Weight (standard model)	460 kg
Weight (track section)	96 kg

Minimální hodnota hlavního jističe - 16 Amper

DESCRIPTION

Feed into the cut and back – motor-powered

Arm height adjustment – manual

Control panel – on a mobile bridge

Log handling – manual

The bigger and stronger version of the popular CTR 550 allows for processing of logs up to 75 cm in diameter. It also uses a bimetallic metal-cutting saw bands, but it is one size bigger. While the size of the bimetallic saw band in CTR 550 is 27 x 0.9 mm, the size of the band in CTR 750 is 34 x 1.1 mm which, combined with a powerful 5.5 kW engine can deal with logs of large diameters.

Unlike CTR 750, this model is equipped with mechanical feed into the cut and back with continuous speed control. That greatly increases comfort of the operator and the overall productivity. The feed is driven by an electric motor with worm gearbox controlled by a frequency converter. You can change the speed of travel simply by turning the potentiometer on the control panel. End positions are secured against impact by means of automatic deceleration and stopping.

The control panel is placed on a mobile bridge of the saw band arm. Thanks to that the operator has closer access to the workpiece when cutting. Height is adjusted using a hand crank with adjustable scale.

Use of a bimetallic saw band which is normally used in metal band saws brings following advantages:

- very simple operation
- single saw band cuts all types of wood without tooth adjustment (sharpening, tooth setting)
- elimination of tedious, technically challenging sharpening and setting of teeth
- you can immediately start cutting wood in professional quality without any necessary experience
- bimetallic saw band easily cuts metal materials in the log such as nails, shrapnel or bullets
- professional three-side hardmetal saw band guidance in guiding heads and robust support of all rotary parts ensure high cutting accuracy and long service life of the saw band
- maximum accuracy, like in professional machines
- no need to purchase tooth sharpener and tooth setting machine
- easy accessibility and low cost of bimetallic saw bands

Powerful 5.5 kW engine ensures full power during fully professional cutting, cutting of high-quality round timber or when cutting very hard materials. Instead of bimetallic metal-cutting band sized 34 x 1.1 mm you can use a special bimetallic wood-cutting band sized 35 x 0.9 mm which (same as the bimetallic metal-cutting band) does not require sharpening and setting of teeth. You can also fit your machine with standard saw-cutting bands (35 x 0.9 mm) identical to those used in higher professional models CTR 710, 800 and 950. Larger teeth in these saw bands allow for increase of productivity when cutting large diameter logs. However, in the above mentioned saw bands it is necessary to sharpen and set the teeth regularly.

The arm is fitted with large aluminium running wheels with accurate balancing against vibrations. The wheel has a groove along its circumference. The groove holds a replaceable rubber-textile belt which creates an optimum contact area between the wheel and the saw band.

The sturdily mounted running wheel is powered through a wedge belt by a professional electrical motor specially balanced against vibrations.

The tensioning wheel system moves within a solid cast iron guiding, which ensures long-term service life and setting accuracy even in long-term machine operation.

CTR series present the latest trends in construction of log saw bands with a special emphasis on maximum accuracy and long-term service life of the machine while ensuring minimum costs. The machines are designed in an original modular execution which allows easy replacement or adjustment of all main technical sections and their individual parts. This in the long-term perspective reduces the maintenance costs and service times and therefore production stoppages as well.

PHOTOGALLERY

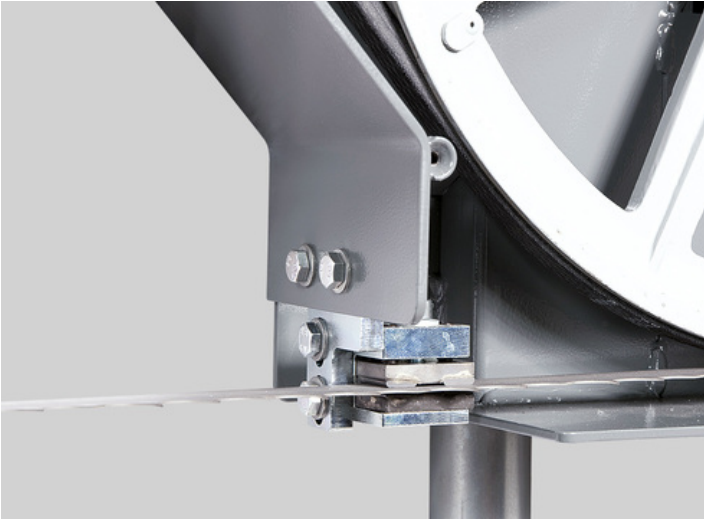
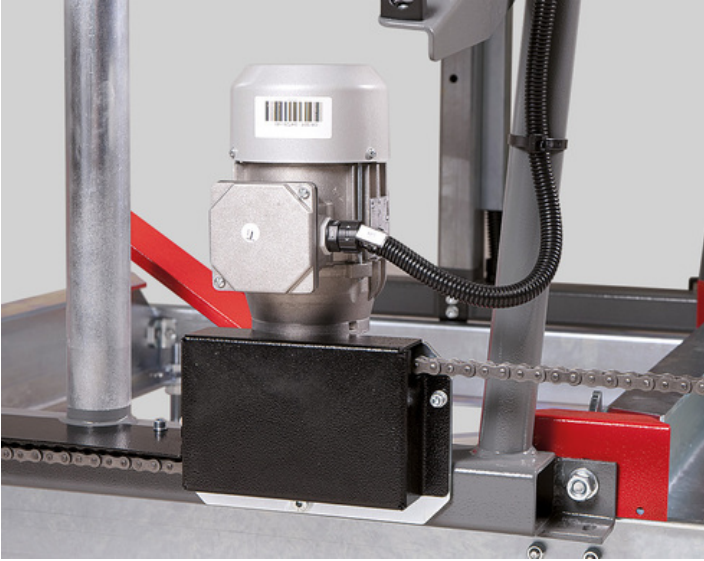
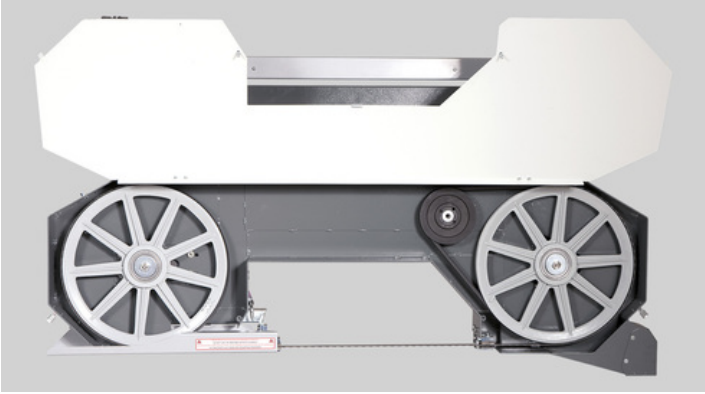

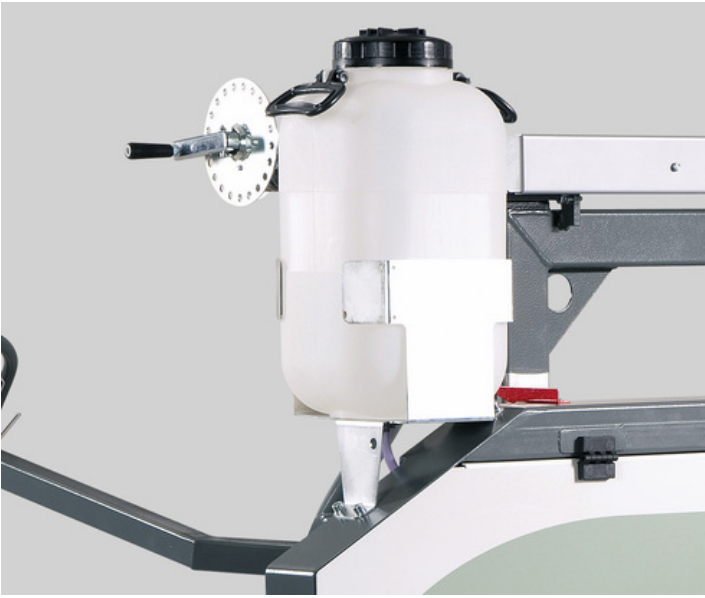

ACCESSORIES

ACCESSORIES – SPECIAL ACCESSORIES



2,25 m

001 Prodlužovací sekce 2,25 m

Track section contain

Contain in basic: 3x cross beams, 2x angle arms, 1x material clamp
Variable points: 1x angle arm, 1x material clamp



002 Páka k navalení kmene

Lever for log loading

Serves as help with manipulation with logs on machine frame.



003 Upínač materiálu s výklopným úhelníkem

Material clamp with variable square



004 Přídavné rameno upínače

Additional clamp arm



005 Ruční pákový mazací lis

Hand Operated Grease Gun

For regular maintenance of the machine according to the lubrication plan. Metal grease gun for 400g cartridges. Equipped with a flexible pressure tube.



006 Plastické mazivo LV 2-3

Grease LV 2-3

400g cartridge for the grease gun.

ACCESSORIES – CONSUMABLE PARTS



040 Kulatý tvrdokov 12 x 4

Hard-metal Plate 12 x 4 mm



041 Klínový řemen 1500 / 1260

Running Wheel Wedge Belt SPB 1500 Wheel Wedge Belt B 1260



Hard-metal Plate 2 x 25 x 15 mm

**045 Deska
tvrdokovu 2 x 25 x
15**

MAXWOOD

- The original saw blades PILOUS MAXwood are available in a variety of types which enables you to process any kind of wood.
- The wide product range not only offers more affordable saw blades for low-volume cutting, but includes also saw blades for fully professional cutting and utmost performance.
- The foundation of all saw blades are top-quality German materials and precise workmanship. The quality of the saw blades is carefully monitored. All saw blades correspond to the strict ISO 9001 norm.
- We have added to our portfolio also an original Munkfors saw blade made by the world's leading manufacturer Uddeholm from Sweden.
- Pilous saw blades are used in dozens of countries around the world. Any wood you cut, the company Pilous will recommend you a saw blade that will fit your needs.

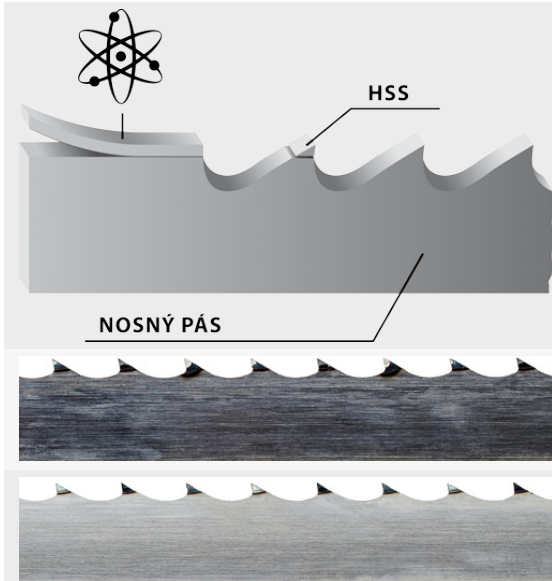

BiMetal

Saw blade with tool steel teeth - completely eliminates the need to sharpen the saw blade as well as frequent blade replacement. Use: soft, hard to extremely hard wood.

HSS

Bearing blade

Stellite

Saw blade with teeth made of Stellite. Tooth setting is completely unnecessary. Use: soft, hard to extremely hard wood.

Carbon spring steel

The most common saw blade for optimum price/performance ratio. Use: soft and hard wood.



Be careful when unpacking welded saw blades. They are in a shipping container in tensioned condition. Remove the saw blade cover only after fitting it onto the machine.

