

# SUPER-WIRELAB.XY

**Ultra Accurate Table-Top Laser Micrometer  
for the Wire Industry**

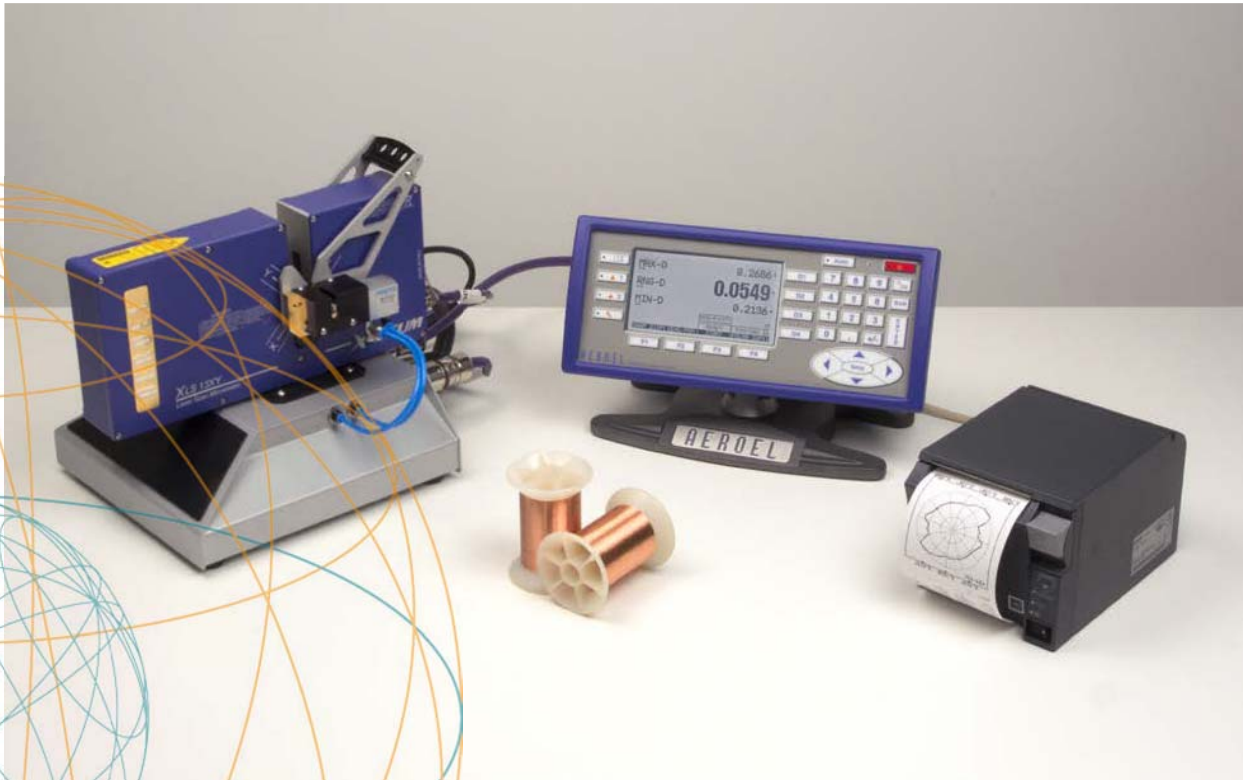

**SUPER- WIRELAB.XY is a high performance table-top laser micrometer designed to be used off-line to check diameter and ovalization of drawn or extruded products.**

It is the ideal instrument to measure **wire samples, optical fibers** and **magnet wire** or to **check the die diameter** by measuring the drawn wire.

It can also be used for the control of rectangular-section products (eg. **metal strip**).

With no other instrument can you measure diameters so quickly, so accurately and so easily!

Ultra-accurate and perfectly reproducible measurements, thanks to an outstanding Laser Technology.

# How does it work?

The SUPER-WIRELAB.XY system uses a laser gauge of the XACTUM series, which allows one to make fast and repeatable measurements. The system can measure products with round or rectangular section (metal strip)

By using a special fixture, the sample is rotated during the measurement: the laser sensor scans the with a 1500 Hz frequency and link each scan to the angular position detected by an encoder (steps of 0.1 °). In this way in the **round section products** you can control the diameter over 360° of the circumference: are detected the average diameter MED-D, the maximum MAX-D, the minimum MIN-D and ovality which is really MAX-D - MIN-D. In the **rectangular section products** during the fixture rotation, the system detects the two dimensions DIM-1 and DIM-2.

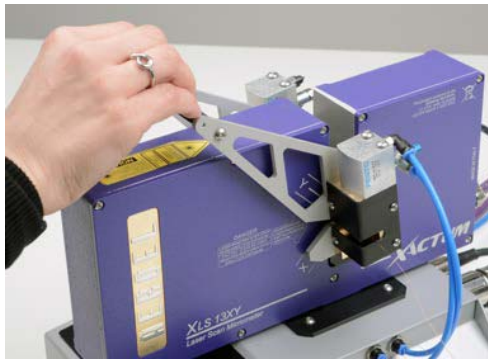
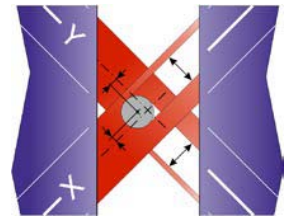

The measured values are displayed on a highly visible backlit LCD display. They are compared with the tolerance limits to check the dimensional conformity of the part. The collection of measurements along the circumference allow also to draw a polar plot of the circular sections.

The fixture is equipped with a pneumatic system for the wire clamping, controlled by foot switch; furthermore the measurement is started automatically during the rotation by the fixture itself.

Through the RS232 serial port or the Ethernet link, the WIRELAB can be connected to an external PC. By using the GageXcom software all measured data are presented in real time to an Excel spread sheet in a way to allow further data processing by the user to personalize the measurement data.

## System Composition

The Basic system consists of:

- XLS13XY dual axis Xactum Intelligent Laser Micrometer
- Hand driven rotating fixture with pneumatic clamping of the sample and with angle position encoder
- CE-100 Operator's Interface Panel, Table-Top version
- Super-Wirelab.XY software pre-installed in the gauge
- Base plate for the gauge
- 0.5 m connecting cable

Some optional accessories are available:

- 42 columns thermal printer with parallel interface for printing the measurement reports
- GageXcom, PC software, Windows (\*) compatible, for real time data transfer into Excel (\*) spread sheets
- Gauge Calibration Report.



## Benefits

**Objective and highly reproducible results** : no matter what the operator's skill level.

**Ultra accurate**: measure to an accuracy that before was only achievable in a metrology room, by using much more expensive equipment and specialized personnel.

**Highly flexible**: different samples and sizes can be measured without system pre-setting or re-mastering.

**Extremely fast and easy to use**: reduce inspection time and improve measurement capability

**Competitive price**: the favorable cost-to-benefit ratio ensures a quick pay back time.

**Quality certification**: measurement results can be immediately recorded and processed by an external computer to get custom made printed reports.

**3 years guarantee**: very long operational life by using high quality components and a solid state laser diode.

# The Super-Wirelab software

## Smart software for easy programming.

Many pop-up menus and sub-menus are available, to make the system set-up and programming very easy. This is usually done by authorized personnel, who will have his own password to access system programming: the operator will only be allowed to recall pre-stored parameters and to make the measurements.

## Multiple language menu

The menu and the display messages are in English, Italian, German and French, each language being selectable by the operator.

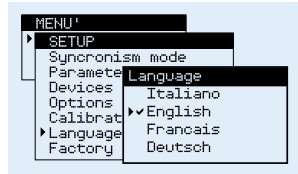

## Gauging flexibility

Two measuring modes are available: ROUND (for round section products) and SQUARE (for rectangular section products.) You can make the following measurements:

### ROUND mode

- Average diameter - MED-D
- Maximum diameter - MAX-D
- Minimum diameter - MIN-D
- Diameter range - RNG-D = MAX-D - MIN-D

### SQUARE mode

- X axis dimension - DIM-1
- Y axis dimension - DIM-2

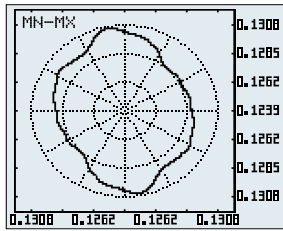

## Polar Diagram

The angle encoder allows the system to draw the polar diagram with the profile of the section (only round products). The diagram can be viewed on the display or printed (optional thermal printer).

## Display millimeters or inches

The measurement unit can be selected by the user; switching the unit is immediate.

## Transparent products can be easily measured

By setting the Glass Logic mode to ON, it is possible to check transparent samples, like optical fibers or glass tubes.

## Highly visible display

The measured values are shown in large characters on a high-visibility, backlit LCD display. 3 values can be displayed at the same time, each one is chosen among the results available in the selected measuring mode.

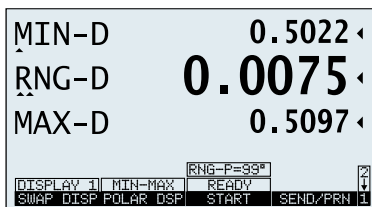

## Tolerance Checking

The user can program the nominal values and the tolerances for each product being measured: after any check the Go, No-Go and Pre-alarm messages are displayed and output signals are activated, to switch-on lamps or to drive other external devices.

## Library for 1000 products

It is possible to save in memory, in a Product Library, up to 1000 different sets of nominal and tolerance values, for each specific part to be checked: to program the system for a new product, just dial in the new part number and recall the new control set.

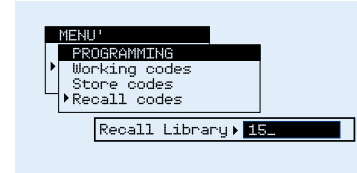

## Permanent self calibration

An exclusive self calibration device is included in each Aeroel gauge: this is based on a real master inserted inside the gauge and checked at each scan. Periodical re-mastering is no longer required, but the Factory Calibration can be changed by the user to fit his own master. At any time the Factory Calibration can be restored.

## No measuring drift due to changing room temperature!

The **NO-VAR** (NO-VARIation) technology allows to get simply perfect diameter measurements even in non thermally controlled environments, automatically compensating the thermal expansion of any part.

## Connecting Wirelab to a PC

Through the Ethernet link, the system can be connected to a PC to transmit the measured data or to be remotely programmed. Using the GageXcom PC software, it is possible to transfer in real time all the measured data into an Excel spread sheet, to allow further data processing and

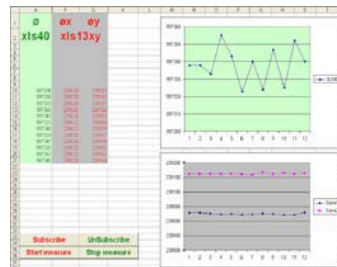

custom report editing, using the standard Excel functions. The system programming is also possible through Excel, using another spread sheet to input the programming parameters being sent to the gauge.

## I/O Lines for Easy Interfacing.

8 output lines for Go, No-Go and Prealarm inputs for each measured dimension

# Specifications

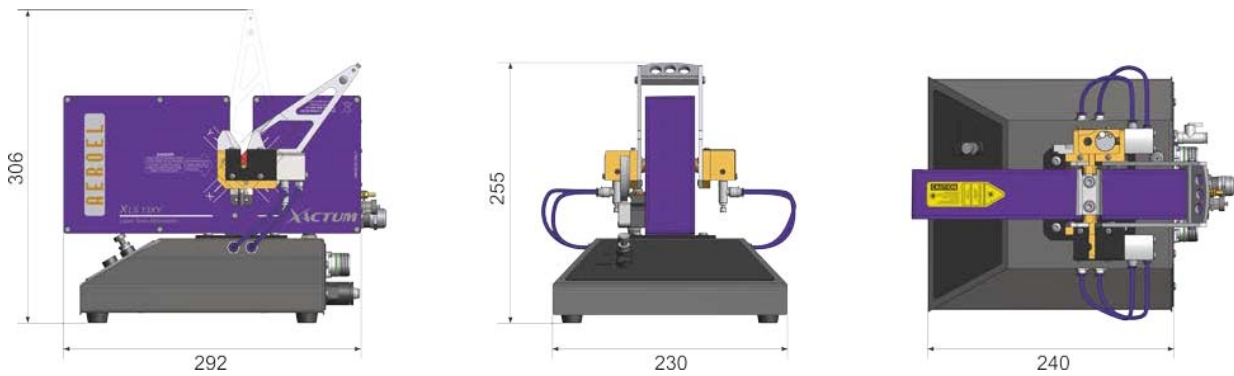

All dimensions are in mm. Dimensions without cables and connectors.

SUPER-WIRELAB		XY13/F	XY 13/B
<b>Gauge Model</b>		XLS13XY/1500/F	XLS13XY/1500/B
<b>Measuring Field</b> (mm)		4 x 4 <sup>(1)</sup>	
<b>Measurable Diameters</b> <sup>(2)</sup> (mm)		0.02 - 1,5	0.05 - 3
<b>Max Diagonal (rectangular sect.)</b> (mm)		1.5	3
<b>Resolution (Selectable)</b> (µm)		10 / 1 / 0.1 / 0.01	
<b>Linearity (Centred Product)</b> <sup>(3)</sup> (µm)		± 0.5 <sup>(4)</sup>	
<b>Linearity (Full Range)</b> <sup>(5)</sup> (µm)		± 1	
<b>Linearity (Reduced Field)</b> <sup>(6)</sup> (µm)		± 0.5	
<b>Repeatability (T=1s, ±2σ)</b> (µm)		± 0.02 <sup>(7)</sup>	
<b>Single Shot Repeatability (±2σ)</b> (µm)		± 0.75 <sup>(8)</sup>	
<b>Beam Spot Size (s,l)</b> <sup>(9)</sup> (mm)		0.02 x 0.1	0.05 x 0.1
<b>Scanning Frequency</b> (Hz)		1500 (X) x 1500 (Y)	
<b>Scanning Speed</b> (m/s)		163	
<b>Gauge Thermal Coefficient</b> <sup>(10)</sup> (µm/m°C)		-11.5	
<b>Laser Source</b>		VLD (Visible Laser Diode); λ = 650 nm	
<b>Dimensions</b> <sup>(11)</sup> (mm)		292 x 240 x 255	
<b>Weight</b> <sup>(12)</sup> (kg)		6.5	

## Note

- <sup>(1)</sup> For  $\varnothing \geq 0.1$  mm; for smaller diameters the field is proportionally reduced up to 1 x 1 mm for  $\varnothing = 0.05$  mm.
- <sup>(2)</sup> Maximum measurable diameters limited by the fixture configuration.
- <sup>(3)</sup> Related to the average diameter  $(X+Y)/2$ . The value is inclusive of the Aeroel's masters uncertainty ( $\pm 0.3$  µm)
- <sup>(4)</sup> For  $\varnothing \leq 1$  mm. Per  $\varnothing > 1$  mm the linearity is  $\pm 1$  µm.
- <sup>(5)</sup> Maximum measurable shift of the average diameter  $(X+Y)/2$ , when a master is moved along the two X and Y axes crossing the centre of the field, checked with  $\varnothing=1$  mm. The value is inclusive of the Aeroel's masters uncertainty ( $\pm 0.3$  µm)
- <sup>(6)</sup> The reduced field is 2 x 2 mm
- <sup>(7)</sup> For  $\varnothing \leq 0.5$  mm. For  $\varnothing > 0.5$  mm the repeatability is  $\pm 0.03$  µm.
- <sup>(8)</sup> For  $\varnothing \leq 3$  mm. For  $\varnothing > 3$  mm the repeatability is  $\pm 1.5$  µm.
- <sup>(9)</sup> Elliptical spot: "s" is the thickness and "l" is the width.
- <sup>(10)</sup> This is the measuring error due to a change in the ambient temperature when measuring a part with zero thermal expansion coefficient (INVAR). This is specified for gauges using a software PRESET for the NO-VAR option and when the rate of change of the ambient temperature is lower than 3°/h. When the NO-VAR option is ENABLED, the gauge thermal expansion coefficient is programmable by the user.
- <sup>(11)</sup> Laser sensor, base and fixture in starting position
- <sup>(12)</sup> Laser sensor, base and fixture

Specifications subject to change without notice. For additional details and complete specifications please see the gauge data sheet.

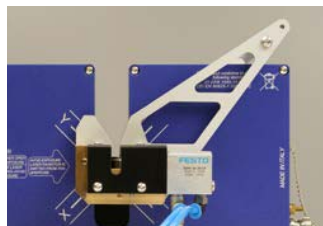

## Hand driven rotating fixture

- Maximum sample **rotation angle**: 100°
- Equipped with **angle encoder** with 0.1° increments
- Pneumatic wire clamping** (compressed air)
- Foot switch** to open the clamps
- Clamps with **adjustable pressure**



## CE-100 Operator's Interface Panel

- Monochromatic **LCD Display**, 240 x 128, backlit
- "Touch-Sensitive" **capacitive keyboard**, with 34 keys and 7 warning LED
- RS485 interface** to connect the XLS gauges
- 8 protected** and optocoupled **outputs**, 4 optocoupled **inputs**, **2 inputs** to the gauge
- Ethernet & RS232 ports** and **Centronics output for parallel printer**
- Available with adjustable **table-top base** or for 19" Rack mounting
- Dimensions**: 132 x 300 x 72 mm (panel alone)
- Weight**: 3.4 kg
- Power supply**: 24 VDC, 100 mA Typical (1 A max)

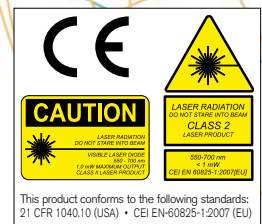

**AEROEL** AEROEL S.R.L.  
Via Pier Paolo Pasolini 35/3  
Pradamano (UD)  
33040 - ITALY  
Phone +39 0432 671301  
Fax +39 0432 671543  
e-mail: [aeroel@aeroel.it](mailto:aeroel@aeroel.it)  
<http://www.aeroel.it>

