

Destaco Body Shop Solutions

Speed Matters

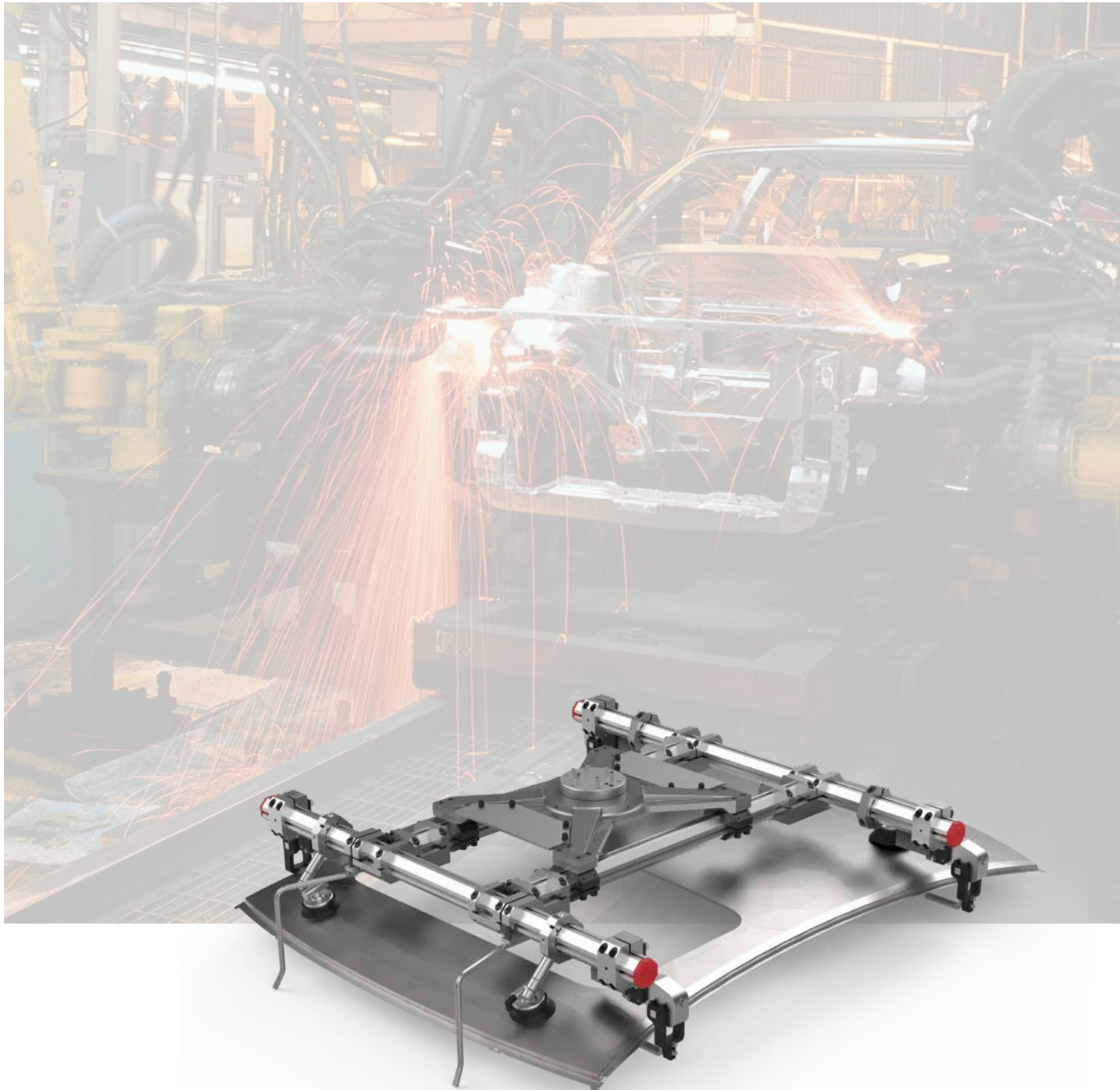

Built on a Strong Foundation



Grippers, Rotaries and Linear Slides

Indexers, Positioners, and Conveyors

End Effectors and Vacuum Products

Manual and Pneumatic Clamps

Power Clamping and Locating

Sheet Metal Grippers

Destaco, a Dover company, is a global leader in the design and manufacture of high-performance automation, workholding and remote-handling solutions. The company serves customers in a variety of end-markets, including the automotive, life sciences, consumer packaged goods, aerospace, industrial and nuclear sectors.

Built on a legacy of more than 100 years, Destaco offers a comprehensive portfolio of products designed to engineer precise movement, placement and control solutions that drive productivity and uptime for manufacturers around the world. The Destaco family of products consists of industry-leading brands such as Destaco Manual Clamps, Power Clamps, and End Effectors; CAMCO™ and Ferguson™ Indexers; Robohand™ Grippers; and CRL™ Manipulators and Transfer Ports.

Destaco is based in Auburn Hills, Michigan, U.S.A. The company has more than 800 employees with 13 locations, in 9 countries, across the Americas, Europe and Asia.

Destaco is part of Dover Corporation, a diversified global manufacturer with annual revenues of \$7 billion. The company delivers innovative equipment and components, specialty systems and support services through four major operating segments: Energy, Engineered Systems, Fluids, and Refrigeration & Food Equipment. Headquartered in Downers Grove, IL, (NYSE: DOV)

More information is available at destaco.com and dovercorporation.com

Focusing all our Resources

New Product Development

Destaco has dedicated resources to design and build the next generation of products and solutions

Customer and Technical Service

Destaco has industry leading global support to address any product and application concerns you may have

Design Tools

Destaco provides an extensive CAD library, sizing software, and online tools to support our global customers



Our Insight Working for You

Application Engineering

We utilize our expertise and complete portfolio of products to create solution that fit our customers' needs and applications

Custom Solutions

if our off-the-shelf solutions don't fit, we will partner with our customers to develop products that will



Body Shop Solutions

Speed Matters

Destaco partners with its customers to design and develop solutions for the following:

- Body-in-white
- Body frame assembly
- Component Machining
- Welding and assembly applications
- Glass handling



Applications



Assembly



Welding



CNC/Machining

BodyBuilder™ Tooling System

BodyBuilder™ octagonal booms and components are designed to maximize productivity, both before and after installation. The flexibility of the system allows modifications to the end effector in minutes, greatly reducing start up time to launch.

- Multiple sizes of octagonal structures offers strength and stability
- Ready-to-assemble mounts and accessories
- Patented alignment system allows quick setup after replacement
- Accessories can be mounted and repositioned quickly and easily



SpiderGrip™ Tooling System

SpiderGrip precision geometric booms and components offers a standard cost effective solution by making it easy for each component to be replaced individually in the robotic cell, dramatically reducing production downtime.

- Booms and components in standard metric sizes
- High strength-to-weight ratio aluminum
- Patented engineered break-away anchors and collars
- Automatic optical and CMM validation points



Accelerate® Tooling for Body Shop

These components are designed to transition from BodyBuilder™ tooling to round tooling structures. This enables customers to improve their productivity, increase robot payloads, and decrease the MOI on the robot.

- Made with high strength 7075-T6 aluminum
- Single tool can be used to tighten both axis
- Increases robot payloads
- Uses BodyBuilder™ patented alignment system



Swivel Arms and Extensions

Swivel arms offer a versatile attachment point for vacuum generators and adaptors, proximity switches, and nest mount brackets. Single end extensions can be used to add linear adjustment to the 360° (3) axes adjustment, when used in conjunction with Transition Swivel Arms or Transition Blocks.

- Swivel arms for mounting onto Bodybuilder™ structures
- Single end extensions for flexible mounting
- Extend Arm Swivel arms offer individual axis adjustment
- Imperial and metric mounting diameters and lengths



Vacuum Products and Mounting

Destaco offers vacuum generators and products designed to increase the speed of pick and place applications. Vacuum generators can be used via apple core mounting or remotely.

- ARV® auto release venturi vacuum generators
- Low-profile 750 Series vacuum generators with blow-off
- Apple Core and bulkhead spring loaded cup mounts
- Block and tube-mounted vacuum Manifolds



Vacuum Cups and Part Handling Magnets

Destaco vacuum cups are offered in different families, and may be offered in different durometers. Vacuum cups are also offered in imperial and metric mounting options which may vary according to the size and type of the vacuum cup.

- Accelerate® Polyurethane Vacuum Cups
- Standard cups in nitrile rubber
- Micro series for high precision applications
- Magnets come in two sizes with urethane pads to avoid damage to delicate surfaces



Enclosed Modular Mini-Clamp

Destaco mini clamp is an enclosed toggle link gripper that can be used to grip the edges of a part for transporting between workstations. No additional fixture components required.

- High clamping force and fast opening and closing action
- Toggle-lock mechanism is protected from contaminants
- Locking Mechanism holds the part if air pressure is lost
- Offers several different jaw and tip options



Tolerance Compensating Power Clamp

The TCC is an enclosed power clamp that is able to hold different metal thicknesses without the need for adding adjustment shims, while maintaining a constant clamping force.

- A complete family of clamps of four sizes
- Field adjustable arm opening angle adjustment
- Fully integrated locking device in every size clamp
- Standard mounting patterns on four surfaces



Enclosed Power Clamps

Power clamps are designed for the requirements of the automotive and sheet metal processing industries. They are the perfect choice when it comes to clamping, holding and positioning metal parts and other components on and in a fixture.

- Clamps sizes range from 12mm diameter cylinder bore to 80mm
- Several clamp arm types and arm opening angles are available
- Double clamp arm and round bore models available
- Hand lever available on pneumatic models

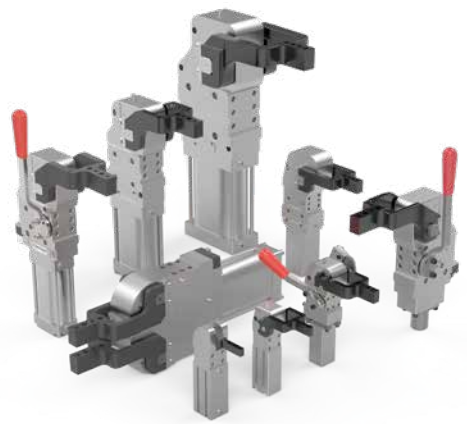

Pneumatic Pin Clamps and Packages

Pin clamps and packages are designed to guide a part into a precise location with the use of hardened steel pins. Pin clamps can also secure a part in place with the use of a powerful toggle mechanism.

- Sealed and protected against contaminants
- Self-locking mechanism in clamping position
- Consistent clamping force throughout clamping range
- Different hook sizes and centering pins available



Precision Guides and Lifters

Precision guides and lifters are ideal for applications where multiple parts are produced on a single production line, with clamping and locating points at different positions and locations.

- Enclosed body protects internal mechanism
- Internal locking mechanisms promotes worker safety
- Locks in extended and/or retracted position
- Multiple mounting surfaces for greater flexibility



Pivot Units

Offered in pneumatic and electric versions, Destaco pivot units have the power to position large fixtures into place for welding and assembly applications.

- Versatile mounting allows vertical and horizontal positions
- Multiple saddle arm opening angles and orientations available
- Electric version allows variable swivel angle over 205° degrees
- Electric version features constant torque with controlled acceleration/deceleration

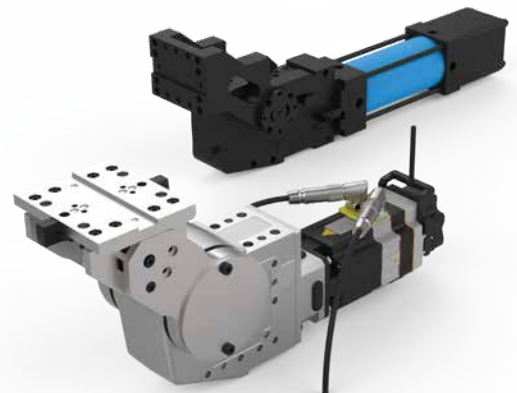

Pneumatic Parallel and Angular Grippers

Grippers, rotaries and slides can be used in a wide array of the body shop and machining applications ranging from heavy-duty engine and part handling to paint shop applications.

- Pneumatic 2-Jaw and 3-Jaw gripping solutions
- 90 and 180 degree angular gripper jaw openings available
- Harsh environment support with spring assist shielded designs
- High temperature applications using Viton® Seals (90 - 360°C)



Manual and Pneumatic Toggle and Swing Clamps

Destaco has long history being used in body shop to secure parts in welding and checking fixtures for assembly and testing applications.

- Heavy-duty and stainless steel models available
- Pneumatic versions available for select models
- Destaco® Toggle Lock Plus available on select models
- Swing clamps provide quick swing-and-clamp movement, while the lever clamp arm pivots up and out of the way



Pneumatic Power Cylinders

The power cylinder is a double acting mechanism, based on a wedge lever principle design that delivers a double stroke action in two stages. The cylinder works in any position and can be used in a wide range of applications.

- Maximum mechanical advantage up to 10:1
- Male threaded or female ISO fit rod end
- Optional end position control with magnetic field sensors
- Double piston rod design option prevents twisting during stroke



CAMCO Servo Positioner GTB Series Rotary Tables

Destaco's CAMCO GTB series rotary tables are the lightest, most compact high accuracy servo positioners available. The exceptional low profile hi-torque output design supports the demands of typical high load inertia applications.

- 60:1 gear ratio for high torque applications
- Up to 85mm large through-hole for utilities
- Zero backlash with direct motor coupling
- Smooth operation using a precision engineered globoidal roller cam design





GLOBAL LOCATIONS

NORTH AMERICA

Corporate Headquarters

Auburn Hills, Michigan
Toll Free: 1.888.DESTACO
Marketing: marketing@destaco.com

Global Technology Center

Auburn Hills, Michigan
Tel: 1.248.836.6700
Customer Service: customerservice@destaco.com

Mt. Juliet, Tennessee
Tel: 1.888.DESTACO
Customer Service: customerservice@destaco.com

Wheeling, Illinois
Tel: 1.800.645.5207
Customer Service: camco@destaco.com

Red Wing, Minnesota (Central Research Laboratories)
Tel: 651.385.2142
Customer Service: sales@centres.com

ASIA

Thailand
Tel: +66-2-326-0812
Customer Service: info@destaco.com

China
Tel: +86-21-6081-2888
Customer Service: china@destaco.com

India
Tel: +91-80-41123421-426
Customer Service: india@destaco.com

EUROPE

Germany
Tel: +49-6171-705-0
Customer Service: europe@destaco.com

France
Tel: +33-4-73545001
Customer Service: france@destaco.com

Great Britain
Tel: +44-1902-797980
Customer Service: uk@destaco.com

Spain
Tel: +34-936361680
Customer Service: spain@destaco.com

Netherlands
Tel: +31-297285332
Customer Service: benelux@destaco.com