



# CNC MACHINES



**KIMLA**

# Why...

are the companies working with Kimla machines...  
so successful?

*Kimla is the single one company in Poland that designs and manufactures such an efficient, fast, and at the same time stable and easy to operate CNC machines. The company reached the leading position thanks to creative projects, effectiveness of action and impressive dynamics of development. The company's position has been also complimented by friendly and respectful attitude towards customers, whose satisfaction and contentedness are the determinants of the Kimla company development. For over 20 years the company has carried out advanced projects, thus gaining vast experience. In the beginnings, the company manufactured electronics and control systems for CNC machines. However, it quickly became clear that the creativity and potential of the employees make it possible to carry out more complex projects. Following suit, the company started to manufacture machines of exceptional performance, speed and technical advancement. Currently, the Kimla machines are offering all the technological machining methods available in the market. The CNC machines are the result of many years of experience and numerous innovative projects.*

*Now, Kimla company is considered to be the industry leader. We are constantly developing and seeking new solutions. Kimla machines achieve industry-leading performance at competitive prices – significantly lower, than those offered by the renowned companies around the world. The CNC machines are upgraded, and their parameter ranges increased. This is possible owing to the expansion of our plants, as well as information and technology infrastructure. As of now, in Poland and abroad there are over 2,500 machines operating and bringing success to their owners.*



# CNC MACHINES



Fiber Laser Cutter Linear



Fiber Laser for tube cutting



Large Format CNC Machining Center



Large Area Milling Machine



Multiple Axis Machining Centre



HSM Linear Machining Centre



Linear Tool Milling Machine



High Speed Linear Cutter



Universal Cutter



5 Axis Milling Machine



Waterjet



High-Speed Engraver



Milling Router

# Fiber Laser cutter linear

## Gold medals MTP

The company presents the latest KiMLa Fiber lasers with linear drivers.

KiMLa's unique Fibre laser comes off the back of the company's high-end CNC equipment. With our integrated CAM/CAD package the machine boasts some flexible programming and control perks. The upshot of this, dynamic analysis of vectors coupled with linear drives allows instant operation whilst maintaining excellent accuracy and producing quality parts.

With superior speeds of 5m/s extreme acceleration and a high resolution measuring system, it is possible to achieve unparalleled efficiency and cutting accuracy.

In the KiMLa Fiber Linear Laser, unprecedented dynamics have been achieved thanks to the application of Renishaw ultra-modern absolute position measurement system with a resolution of 0,000001 mm, as well as position, speed and acceleration controls.

Why Lasers Fiber Linear are multiple winners of MTP Gold Medal - Consumers Choice?

They are distinguished by the following strengths:

- innovative technology
- well priced
- low operating cost
- user-friendly interface
- fantastic performance
- low maintenance



# Fiber Laser cutter linear

linear drives



- PROCESSED MATERIALS:**
- carbon steel;
  - stainless steel;
  - aluminium;
  - copper;
  - brass.

## Fiber Laser with Linear Drives

Fiber Laser with linear drives, facilitating fast and efficient cutting of various shapes out of sheet metals is the newest product designed by Kimla — the leading manufacturer of CNC machines.

The difference in operation of Kimla lasers and CO<sub>2</sub> lasers is especially visible in the case of thin sheet metals, up to 5 mm of thickness. The cost of metal cutting with the use of Fiber Linear laser may be drastically reduced, thanks to much higher power efficiency, reaching 30% (in CO<sub>2</sub> lasers — merely up to 5%) and greater energy concentration, stemming from the shorter wavelength.

The Kimla fibre lasers feature many advantages: superb quality, high efficiency, competitive price and the possibility of customization to individual customer's needs.

The Kimla lasers are manufactured in many configurations and in operating areas.

This diversification pertains to: the degree of automation, laser source power and equipment. Kimla manufactures lasers with one worktable, in which an important factor is a low price for high performance; as well as production lasers with automatic pallet change and featuring ventilating hood systems, nesting and production preparation systems.

The Kimla lasers are machines featuring the highest efficiency, maximum speed and acceleration. Thanks to unique functionalities of very fast cutting of thin sheet metals, they are perfect for cutting out as an alternative to lathe punching-presses. The later ones were — up to now — considered the cheapest technology for cutting sheet metal details.

Flashcut and Powercut Linear lasers have won many gold medals at the Poznań International Fair (Międzynarodowe Targi Poznańskie (MTP); the largest trade fairs of modern industrial technologies — ITM Polska MACH-TOOL) and STOM trade fairs in Kielce.

## Technical data

### Laser specification

	Finecut LASER LINEAR	Flashcut LASER LINEAR	Powercut LASER LINEAR	ExtremeCut LASER LINEAR
Laser power	up to 3kW	up to 6kW	up to 15kW	up to 20kW
Work area	1000 x 2000 mm	1500 x 3000 mm 2000 x 4000 mm	1500 x 3000 mm 2000 x 4000 mm 2000 x 6000 mm 2000 x 8000 mm 2000 x 10000 mm	1500 x 3000 mm 2000 x 4000 mm 2000 x 6000 mm 2000 x 8000 mm 2000 x 10000 mm 2500 x 3000 mm 2500 x 6000 mm 2500 x 8000 mm 2500 x 12000 mm 3000 x 10000 mm
Linear drives	✓	✓	✓ (HP)	✓ (HP)
Automatic pallet changer	✗	✓	✓	✓
Safety laser barriers	✗	✓	✓	✓
Doors on all sides of the laser	✓	✓	✓	✓
Dust separator with Ultraweb filters	✗	✓	✓	✓
Adjustable focal distance of the head (zoom)	✗	●	✓	✓
Automatic height adjustment	✓	✓	✓	✓

### Control and software

CAD/CAM/NEST/CNC Control System	✓	✓	✓	✓
Nesting with production management	●	1 station	1 station	2 stations
Connection with ERP system	✗	●	✓	✓
Flycut	●	✓	✓	✓
Pallet position control, servo	✗	✓	✓	✓
Automatic switching of suction zones	✓	✓	✓	✓
Dynamic vector analysis	✓	✓	✓	✓
Frequency of position adjustment	20kHz	20kHz	20kHz	20kHz
Electronic adjustment of the gantry angle	✓	✓	✓	✓
Parametric beam modulator	✓	✓	✓	✓
Common cutting lines	✓	✓	✓	✓
Material position detection	✓	✓	✓	✓
Detection of a nozzle travelling off the sheet metal	✓	✓	✓	✓
Too low a gas flow detection	✓	✓	✓	✓
Collision detection with automatic resumption	✓	✓	✓	✓
Frog jumping	✓	✓	✓	✓
Smooth processing of splines and polylines	✓	✓	✓	✓
Absolute straight-edge with the resolution of 1 nm	✓	✓	✓	✓
Double-sided gantry drive	✓	✓	✓	✓
Automatic cutting off with edge control	✓	✓	✓	✓
Pipe machining system	✗	●	●	●
Printing head for describing details	✗	●	●	●
Scanning head	✗	●	●	●
Automatic nozzle change	✗	●	●	●

### Speed, efficiency, accuracy

Operational speed values	up to 150 m/min	up to 180 m/min	up to 230 m/min	up to 230 m/min
Positioning length	0.03 mm	0.03 mm	0.02 mm	0.02 mm
Repeatability of positioning	0.001 mm	0.001 mm	0.001 mm	0.001 mm

### Additional information

Warranty	24 months	24 months	24 months	24 months
----------	-----------	-----------	-----------	-----------

**NEW****KIMLA**

# Fiber laser for tube cutting

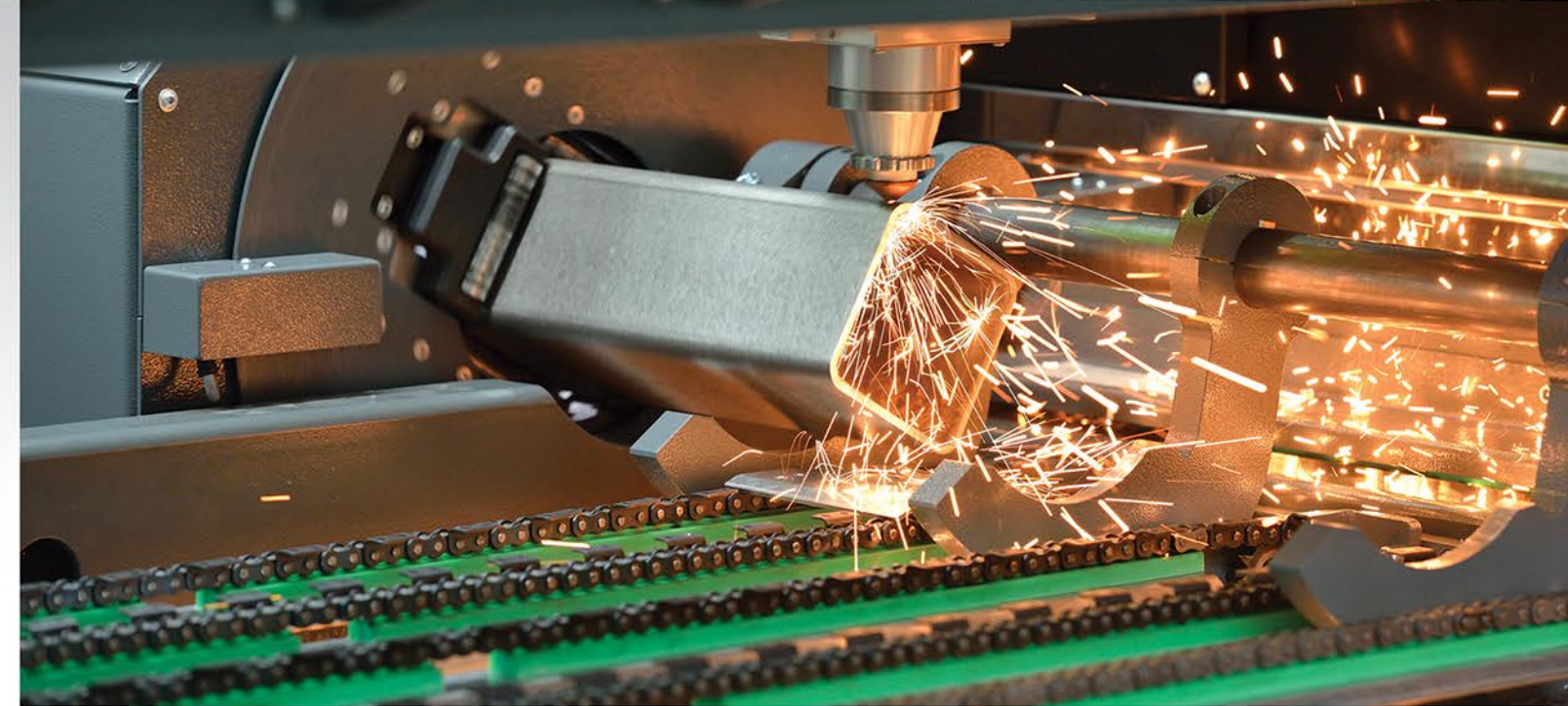
**PROCESSED MATERIALS:**

- carbon steel;
- stainless steel;
- aluminium;
- cooper;
- brass.

**Fibr laser for tube cutting**

Fiber Laser for tube cutting from the brand Kimla is the first of its kind to be produced on the Polish market. It is based on the Kimla Powercut model, manufactured for years, thanks to which it shares most of the proven technical solutions, and at the same time still has the functionality of sheet metal cutting. This solution makes it possible to replace two machines with a compact unit that saves space in the production hall.

The construction used by us allows the work with rectangular 100x100 mm profiles, as well as round tubes with 150 mm diameter and a length up to 6 meters (optional - 12 meters). Depending on the size of the working range of the laser, the length of the cut-off sections can be 3, 4 or 6 meters. This is the only laser on the market that combines the above features.

The difference in the operation of Kimla lasers compared to CO<sub>2</sub> lasers is particularly visible in the case of thin sheets up to 5 mm. The costs of cutting metal with the Laser Fiber Linear can be calculated in many ways, thanks to a significantly higher energy efficiency of up to 30% (in CO<sub>2</sub> lasers only up to 5%) and a higher energy concentration resulting from the shorter wavelength.

**Technical data of the laser**

Working Range	1500 x 3000 mm max. profile length 6 m, max. length of cut detail 3 m	2000 x 4000 mm max. profile length 6 m, max. length of cut detail 4 m	2000 x 6000 mm max. profile length 6 m, (opt.12m), max. length of the cut detail 6 m
Laser power: up to 8 kW	Linear drives (HP)	Access doors from all sides of the laser	
Diameter of machined tubes up to 150 mm	Automatic pallet changer	Dust extractor with filters	
Dimension of machined profiles up to 100x100 mm	Laser Safety Barriers	Automatic height adjustment	

**Control and Programming**

- CAD/CAM/NEST/CNC control system
- Nesting with production management
- Connection to ERP system
- Flycut
- Control of pallet position Servo
- Automatic switching of the suction zones
- Dynamic Vector Analysis
- Frequency of the position controllers 20 kHz
- Electronic regulation of the gantry angle
- Parametric beam modulator
- Common cut lines
- Detection of the material position
- Detection of the nozzle moving off the sheet
- Detection of insufficient gas flow rate
- Collision detection with automatic resumption
- Connection of paths with arches (frog jump)
- Smooth operation of splines and polylines
- Absolute digital scale with a resolution of 1 nm
- Gantry both sides driven
- Automatic cut off with edge control

**Optional**

- Printer head for describing the details
- Scanning head
- Automatic nozzle change

**Speed, performance, accuracy**

- Working speeds up to 180 m/min
- Positioning accuracy 0.02 mm
- Repeatability of positioning 0.001 mm

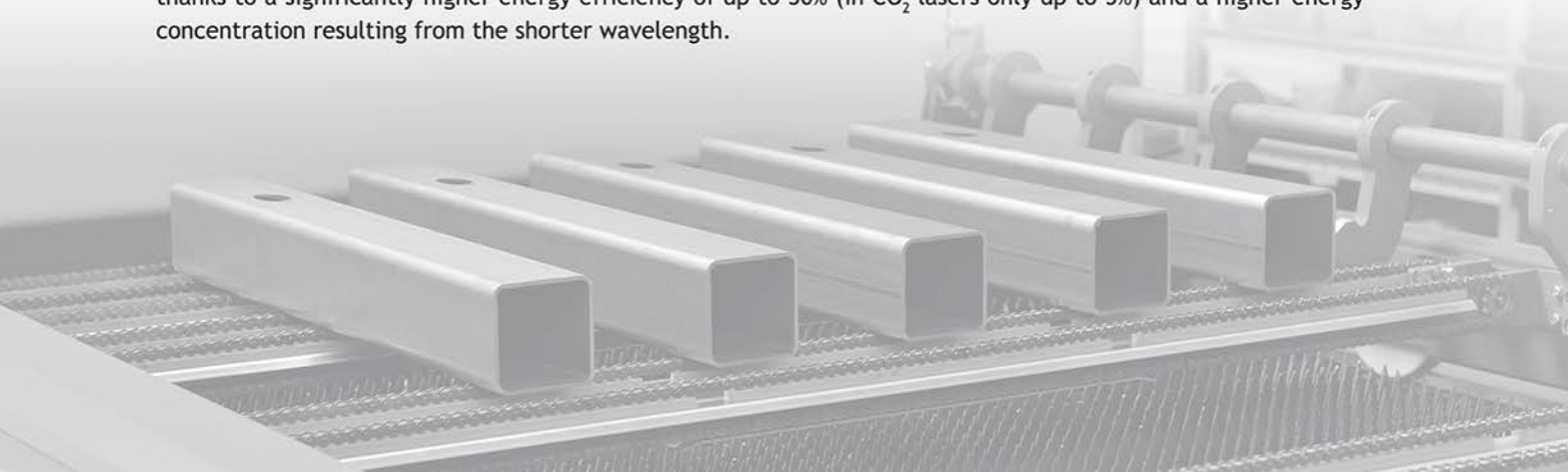

# Large format CNC machining center

linear drives

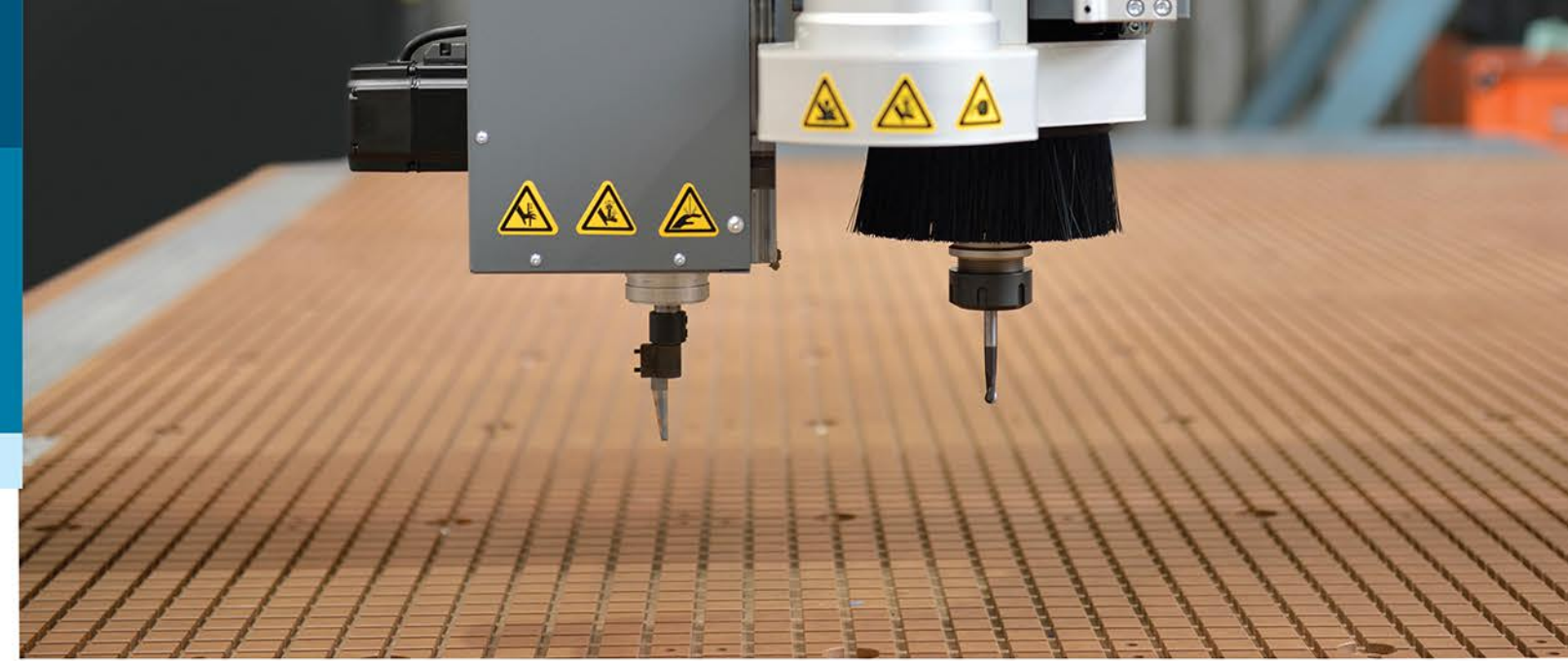

The large format CNC machining centre BPFT Linear is a high performance machine designed as a platform for chip machining in at least 3 axes. Thanks to the use of additional controlled axes, the machining center combines the functionality of a milling machine, lathe, drill, tapping machine, cutting machine, creasing machine, pouring machine etc.

Kimla CNC machining centres are based on industrial routers, thanks to which they have taken over all their advantages, among others: gantry construction with servo drives on both sides with electronic compensation of the gantry angle. Depending on the configuration and the additional equipment, the unit can be used for processing plastics, composites and, above all, all metal sheets of light alloys (e.g. aluminium, brass) and steel sheets.

This is possible thanks to the modern, coherent and much stiffer base construction of the machine compared to industrial routers.

In order to meet the requirements of heavy machining of some metals, spindles with an output of up to 20 kW are installed in machining centres, with installed tool change either linear or rotary.

In the linear version, the machine has magnetic linear motors with the highest positioner frequency available on the market, which is 20 kHz. The motors are designed using magnets with high power density, ensuring greater performance while maintaining the same mass in relation to the solutions available on the market. For motor positioning itself, the measuring system with an accuracy of 0.005 mm/m and a resolution of 0.000001 mm were used. This solution ensures that the machine is very precise and very fast. In this equipment there is no wear effect of the drives, or the notion of backlash, since the drive is directly converted by means of the magnetic field. The machine we offer is the first industrial router with linear drives worldwide.

Large format machining centres are usually equipped with a vacuum hybrid table including a vacuum pump from the German company Becker with a capacity of 250 m<sup>3</sup>/h. This type of table allows the material to be securely fixed, both in the form of arches and elements with irregular shapes, using standard vacuum blocks. In the version with T-groove table, the machined material can be mechanically fixed directly to the table or in a vice.

## Large format CNC machining center

### BASIC OPTIONS

Work area dimensions* [mm]	Width [mm]	1600, 2100, 2600, 3100
	Length [mm]	2100, 2500, 3000, 3100, 4100, 5100, 6100, 7100, 8100, 10100, 12100
	Z axis range [mm]	200, 300, 400, 500, 600, 700
Spindles	24 000 rpm	7.0kW, 9kW, 12kW, 14kW, 16kW, 18kW, 30kW
	40 000 rpm	5kW
	50 000 rpm	3kW
Cooling	Air Refrigerating unit	
Control system	Digital AC Servo Drives	
Automatic Tool Changing	no change linear storage rotating storage	
Table type	T-slot table, negative pressure table, vacuum table, hybrid table	
Automatic correction of the tool length Panel with control computer		

### ADDITIONAL OPTIONS

Oil mist cooling	Automatic	
Heads	Active, oscillating knife	
	Creasing	
	Active, drag knife	
	Knife for cutting film	
	Writing	
Scanner	touch, laser	
	Rotary axis	
"B" on the table "B" inclined spindle "C" on the spindle (for angular units)		

Pressure mats, Laser curtains, OHS fence, Presser foot, Suction foot, Pressure and suction foot, Dust extraction system, Basing system, Camera sighting system, Detail description printing system



### PROCESSED MATERIALS:

- non-ferrous metals: aluminium, copper, brass, etc.;
- plastics;
- composite materials, Dibond, MDF;
- layered materials, furniture boards, laminates;
- solid wood and wood-based materials.

\* - non-standard dimensions of the work area available

# Large Area Milling Machine



Large Area Milling Machine

### BASIC OPTIONS

Work area dimensions* [mm]	Width [mm]	1600, 2100, 2600, 3100
	Length [mm]	2100, 2500, 3000, 3100, 4100, 5100, 6100, 7100, 8100, 10100, 12100
	Z axis range [mm]	200, 300, 400, 500, 600, 700
Spindles	24 000 rpm	7.0kW, 9kW, 12kW, 14kW, 16kW, 18kW, 30kW
	40 000 rpm	5kW
	50 000 rpm	3kW
Cooling		Air
		Refrigerating unit
Control system	Digital AC Servo Drives	
Automatic Tool Changing	no change linear storage rotating storage	
Table type	T-slot table, negative pressure table, vacuum table, hybrid table	
Automatic correction of the tool length		
Panel with control computer		

### ADDITIONAL OPTIONS

Oil mist cooling	Automatic
Heads	Active, oscillating knife
	Creasing
	Active, drag knife
	Knife for cutting film
	Writing
Scanner	touch, laser
	Pouring
Rotary axis	"B" on the table "B" inclined spindle "C" on the spindle (for angular units)

Pressure mats, Laser curtains, OHS fence, Presser foot, Suction foot, Pressure and suction foot, Dust extraction system, Basing system, Camera sighting system, Detail description printing system

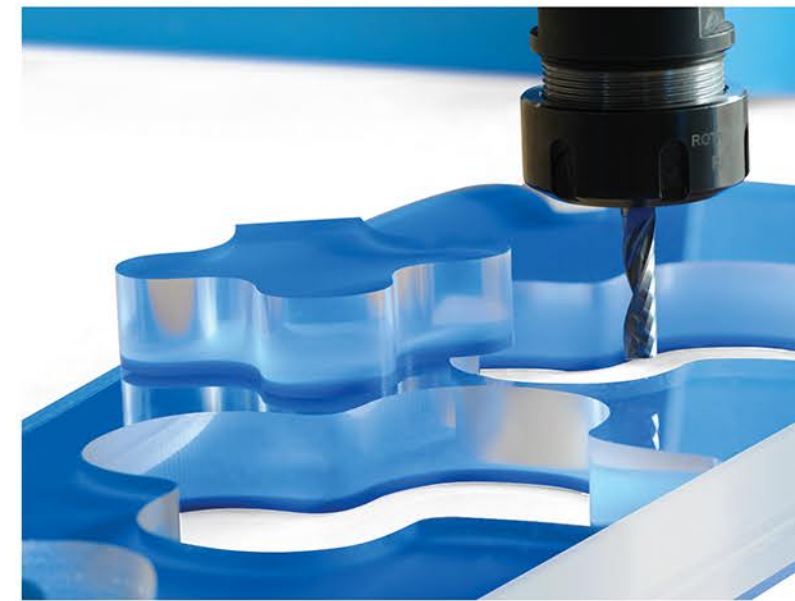

### PROCESSED MATERIALS:

- non-ferrous metals: aluminium, copper, brass, etc.;
- plastics;
- composite materials, Dibond, MDF;
- layered materials, furniture boards, laminates;
- solid wood and wood-based materials.

Large area milling machines are devices designed for heavy production works, featuring high efficiency, and robust and stable construction.

The milling machines perform both flat (e.g. cutting shapes out of sheet metals, drilling on the basins of two-dimensional drawing), and three-dimensional milling tasks (e.g. preparation of models for casting, laminating, thermal forming). In milling works, in which a number of tools are used, the routers are equipped with systems of automatic tool changing with storage. Automatic tool changing is available in linear or rotational version, depending on the size of the table and the customer's needs in terms of machine efficiency. Industrial machines are equipped with suction foot or suction hood. It is an effective means of dust extraction from the milling station. Suction hood may be set automatically on different heights, depending on the length of the attached tool, so that secure the most effective dust extraction. Large area milling machine tables may be executed in the basic version, that is T-slot tables. The most common, however, are vacuum tables, facilitating very strong fixation of large format materials,

without the need to use mechanical fixation. If a vacuum tables does not provide sufficient fixation, we provide our customers with hybrid tables. It is a table with very dense T-slots, to which vacuum is supplied. Owing to this, there is a possibility of adhering the large format elements by suction, as well as screwing in smaller elements, fixation devices or additional equipment, e.g. rotary axis.

As a standard, vacuum tables are equipped with one or two vacuum pumps from Becker company, featuring efficiency of 250 m<sup>3</sup>/h. This solution brings both high performance and low noise emission.

Large area milling machines are always executed in configuration with travelling gantry, with double-sided drive, servomotors and electronic compensation unit of the gantry angle.

Kimla company manufactures milling machines not only in standard version, but also in a special version with pneumatic conveyor, with automatic loading and automatic unloading.

\* - non-standard dimensions of the work area available

# Multiple Axis Machining Centre

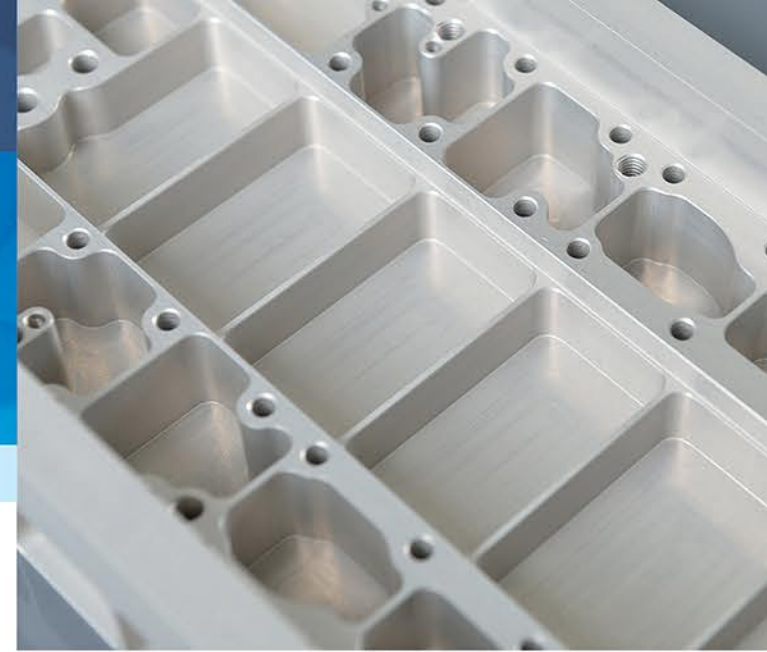

Multiple axis machining centre is a highly efficient device, designed as a platform for machines performing machining works on at least 3 axes. Thanks to the employment of additional controlled axes, the machining centre combines functionality of many machines: milling machine, turning lathe, drilling machine, tapping machine, as well as cutting, creasing and pouring device, etc.

The Kimla multiple axis centres were designed on the basis of industrial routers. Owing to this, they feature all their advantages, e.g.: gantry execution with double-sided drive, servomotors and electronic compensation of gantry angle.

Depending on the configuration and additional equipment, the machine may be used in machining plastics, composites, but first and foremost - light alloy sheet metals (e.g. aluminium, copper) and steel metals.

It is possible through modern, compact, and much more rigid base structure of the machine in comparison to industrial routers.

In order to meet the requirements of heavy machining of some of the materials, the machining centres are equipped with high power spindles - even up to 20 kW, with automatic tool changing with revolving or linear storage.

Multiple axis machining centres are - most frequently - equipped with grooved vacuum table, together with vacuum pump from the German manufacturer, Becker, featuring efficiency of 250 m<sup>3</sup>/h. This type of the table allows for secure fixation of the material, both in the form of sheets, as well as irregularly-shaped elements; fixation is executed with standard vacuum blocks. In the version with T-slot table there is the possibility of fixating the mechanically machined material directly on the table or in a vice.

## Multiple Axis Machining Centre

BASIC OPTIONS	
Work area dimensions* [mm]	Width [mm] 1600, 2100, 2600, 3100
	Length [mm] 2100, 2500, 3000, 3100, 4100, 5100, 6100, 7100, 8100, 10100, 12100
	Z axis range [mm] 200, 300, 400, 500, 600, 700
Spindles	24 000 rpm 7.0kW, 9kW, 12kW, 14kW, 16kW, 18kW, 30kW
	40 000 rpm 5 kW
	50 000 rpm 3 kW
	Cooling Air
Control system	Digital AC Servo Drives
Automatic Tool Changing	no change linear storage rotating storage
Table type	T-slot table, negative pressure table, vacuum table, hybrid table
Automatic correction of the tool length Panel with control computer	
ADDITIONAL OPTIONS	
Oil mist cooling	Automatic
Heads	Active, oscillating knife
	Creasing
	Active, drag knife
	Knife for cutting film
	Writing
	Pouring
Scanner	touch, laser
Rotary axis	"B" on the table
	"B" inclined spindle
	"C" on the spindle (for angular units)
Pressure mats, Laser curtains, OHS fence, Presser foot, Suction foot, Pressure and suction foot, Dust extraction system, Basing system, Camera sighting system, Detail description printing system	

\* - non-standard dimensions of the work area available



### PROCESSED MATERIALS:

- steel;
- non-ferrous metals: aluminium, copper, brass, etc.;
- plastics;
- composite materials, Dibond, MDF;
- layered materials, furniture boards, laminates;
- solid wood and wood-based materials.



# Machining Centre HSM Linear

linear drives

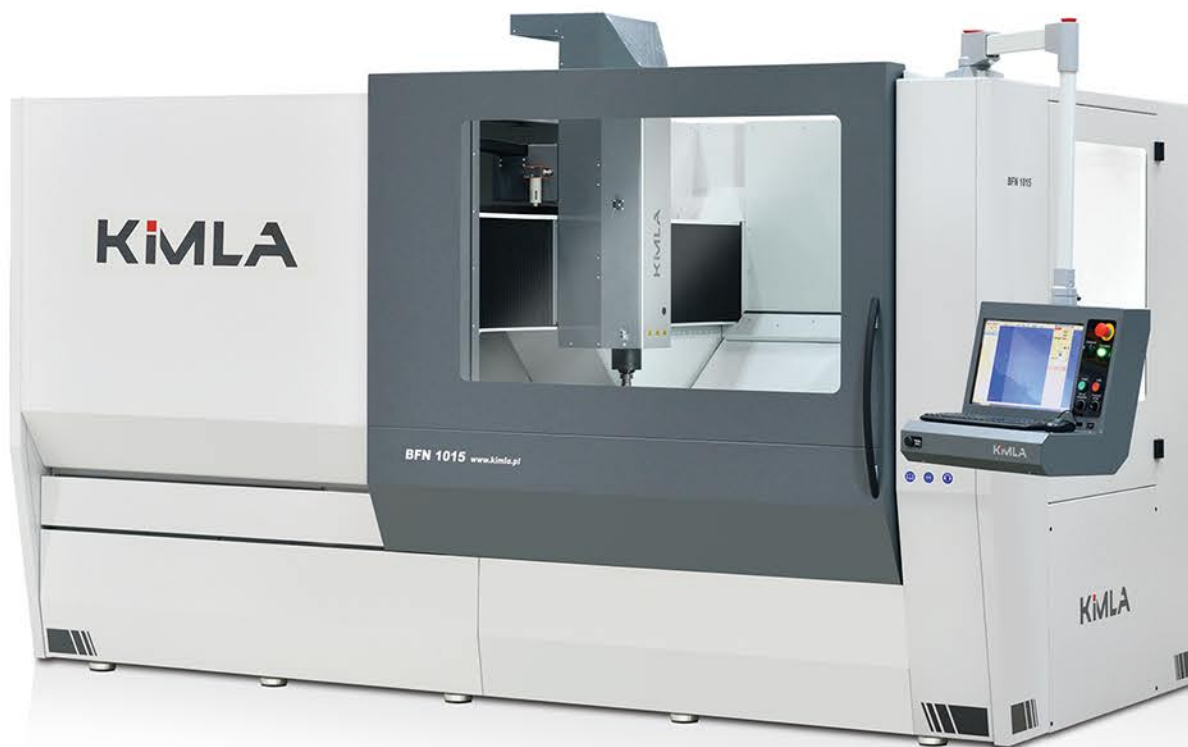

HSM Linear machining centre is a machine tool for precision and tool works. It proves useful wherever extremely high positioning precision is required.

Instead of the traditional circulating screws used up to now in CNC machines in X Y Z axes, linear drives and measurement systems - with the resolution of 1 nm and accuracy of 5 micrometers per meter - were employed.

Linear drives transmit the drive force without friction and contact, solely with the use of magnetic field. Thanks to this, there is no return play, irrespective of the machine's age. The drive does not feature wearable parts that could have an effect on the deterioration of milling quality while in operation.

In the gantry design of the machine tool with movable table, Kimla company uses solutions that are proved successful and developed for over 20 years.

HSM Linear machining centre is offered with customized working range, as per customer's needs. The standard feature of the device is T-slot work table, sensor of the tool length, oil mist cooling, high-speed spindle of 7-20 kW of power and automatic tool changing with the revolving storage. These solutions provide for highly efficient and precise machining.

Technological functionality of the machine may be extended through utilisation of additional equipment, e.g. 3D scanning head (for scanning of 2D outlines of 3D objects, support for precision basing), rotary axis with poppet-head with full simultaneous interpolation of all axes.

HSM Linear machining centre is designed to machine material, e.g.: steel, aluminium, copper, brass, plastics, composite materials, etc.

## HSM Linear Machining Centre

### BASIC OPTIONS

Work area dimensions* [mm]	Width [mm]	1000, 1300, 1500
	Length [mm]	625, 750, 1000, 1250, 1500, 2000
	Z axis range [mm]	200, 250, 300, 350, 400, 500, 600
Spindles	24 000 rpm	9kW - 20kW
	40 000 rpm	5kW
	50 000 rpm	3kW
	Cooling	Air Liquid + Refrigerating unit
Control system	Linear drives	
Automatic Tool Changing	Revolver storage	
Table type	T-slot table, vacuum table, hybrid table	

Automatic correction of the tool length  
Panel with control computer

### ADDITIONAL OPTIONS

Oil mist cooling	Automatic	
Scanner	touch, laser	
Rotary axis	"B" on the table	
Laser barriers	Tapping head, Suction foot	



- PROCESSED MATERIALS:**
- tool steels (toughened or hardened);
  - aluminium;
  - copper;
  - brass;
  - plastics;
  - composite materials.

\* - non-standard dimensions of the work area available

# Tool Milling Machine linear

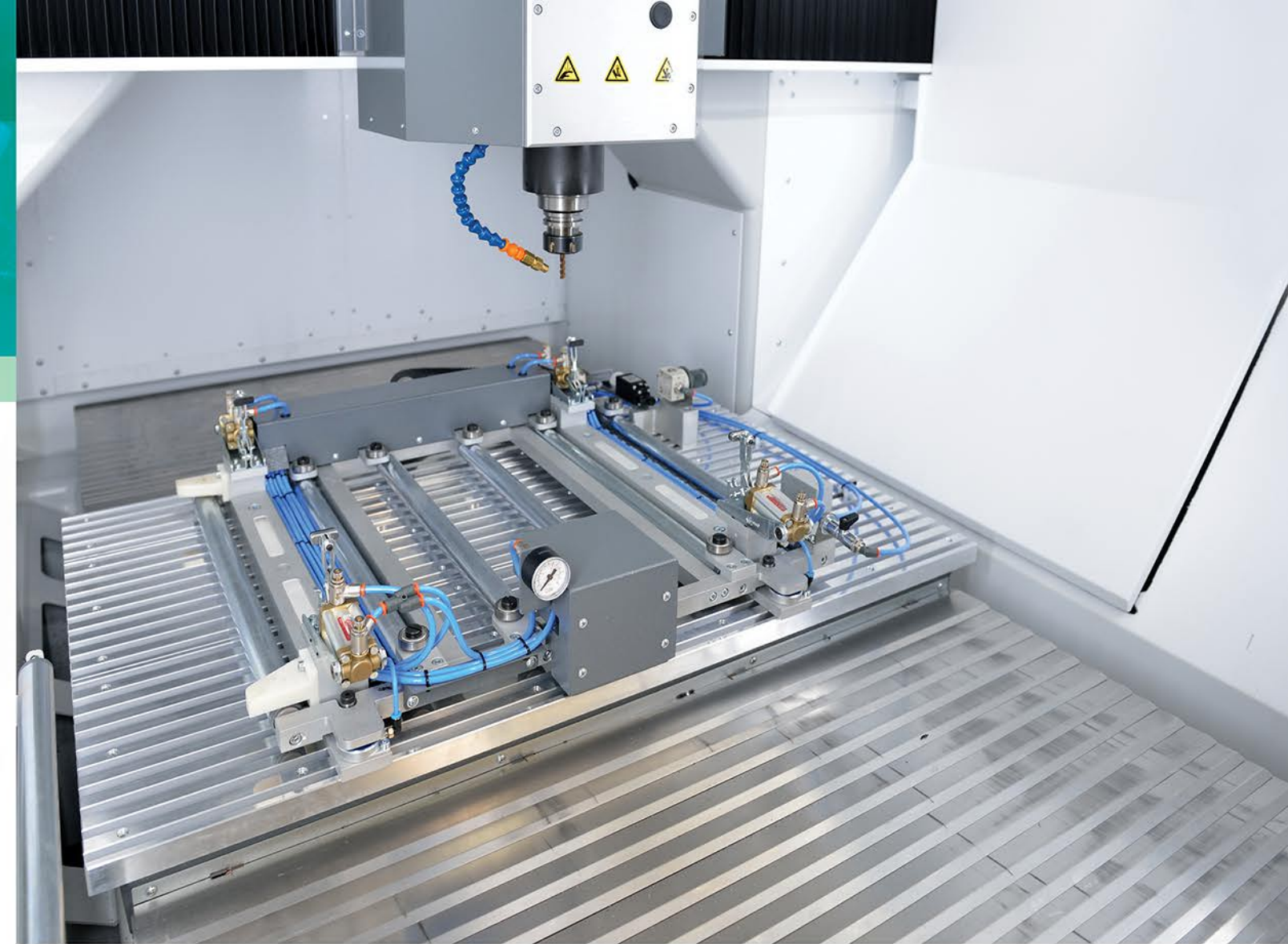

linear drives



Tool milling machines are devices used for industrial engraving or milling. They are perfect for high-efficiency aluminium machining - both for cutting out sheet metals, as well as aluminium milling from solid plates. They are used also for preparation of extruding, stamping and blanking dies. Most frequently, the machines are equipped with high-speed spindles, liquid-cooled in closed circulation with automatic tool changing. At the same time, the refrigerating unit with cooling liquid temperature stabilization minimizes the effect of spindle's thermal drift. The machines may also be equipped with simple spindle without automatic tool changing when machining works are carried out with one tool and the frequency of tool changes is not high.

As a standard, the tool milling machines are equipped with a booth that secures the work area and an oil mist for cooling tools. In the case of larger work areas, the booth is equipped with doors on all sides of the machine. It facilitates free access to the details from any side.

The machines are executed in parallel configuration of kinematics with travelling table. It provides for a very high precision and possibilities of mapping complex paths. CNC tool milling machines may be equipped with T-slot table (standard) or vacuum table with vacuum pump from the German company Becker, featuring capacity of 40-250 m<sup>3</sup>/h.

## Tool Milling Machine

### BASIC OPTIONS

Work area dimensions* [mm]	Width [mm]	700, 1000, 1100, 1300, 1500 ...
	Length [mm]	500, 625, 750, 1000, 1250, 1500, 2000 ...
	Z axis range [mm]	200, 250, 300, 350, 400, 500, 600 ...
Spindles	24 000 rpm	9kW, 12kW, 14kW, 16kW, 18kW
	40 000 rpm	5kW
	50 000 rpm	3kW
	Cooling	Air Liquid + Refrigerating unit
Control system	Digital AC Servo Drives	
Automatic Tool Changing (ATC)	no change revolver storage	
Table type	T-slot table, vacuum table, hybrid table	
Automatic correction of the tool length		

### ADDITIONAL OPTIONS

Oil mist cooling	Automatic
Scanner	touch, laser
Rotary axis	"B" on the table

\* - non-standard dimensions of the work area available

### PROCESSED MATERIALS:

- steel;
- aluminium;
- plastics;
- composite materials;
- MDF;
- HPL;
- laminates.



KIMLA

# High Speed Linear Cutter



linear drives

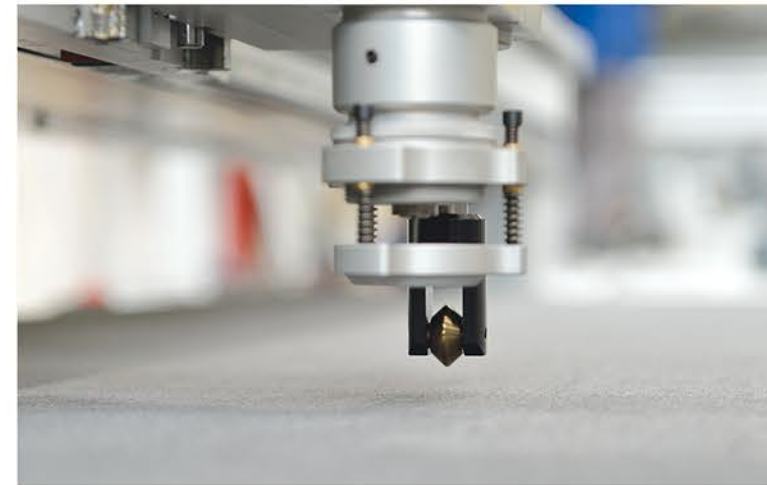

The first cutter worldwide, manufactured in series on linear drives - opens new production possibilities in many industries. High Speed Cutter is available in various operational fields and equipment options. Compact design of the machine was furnished with innovative solutions, based on linear drives, devised and adapted solely for this machine.

New cutter with linear drives and a fully new design provides for even greater efficiency and better work quality. High-efficiency cutting is possible thanks to the employment of direct positioning measuring systems featuring ultra high accuracy - measurement resolution equals 0.001  $\mu\text{m}$ , and the positioning repeatability amounts to 1  $\mu\text{m}$ . The linear drives featured in the cutter are almost maintenance-free. The magnetic drive does not cause any friction, thus it is not subject to wear, and this eliminates costly repairs within the operational life of the machine.

Proprietary control system with dynamic vector analysis was designed especially for this machine, so that use the potential of the company's linear drives to the maximum. From now on, even the most complex shapes will be machined with an effectiveness and precision unmatched ever before. Built-in all-in-one system contains all necessary CAD/CAM/CNC/NESTING modules, which secures high comfort and precision of machining.

High Speed cutter covers a very wide range of machined material, thanks to the possibility of expansion with many additional options. It is perfect in cutting: leather, fabrics, fibres, composite, sealant and layered materials, paper, cardboard, film.

The conveyor is a belt table that automatically moves the material, thanks to which the comfort and efficiency of work increases. The conveyor facilitates continuous work, which limits unnecessary downtimes. Additionally, the machine may be equipped with receiving and loading table, sighting system, oscillating head, milling head, writing head, stamping head, creasing head.

## High Speed Linear Cutter

### BASIC OPTIONS

Work area dimensions* [mm]	Width [mm]	1800, 2200, 2700, 3200, *
	Length [mm]	1600, 2100, 2500, 3100, 4100, 5100, 6100, *
	Z axis range [mm]	200, *
Oscillating knife	pneumatic electric - 1x servo, 2x servo	
Control system	Digital AC Servo Drives	
Table type	vacuum	
Control computer		

### ADDITIONAL OPTIONS

Heads	Milling
	Creasing
	Stamping
Scanner	touch, laser
Remote panel, Pressure mats, Writing head, Basing system, Conveyor - belt transport table, Receiving and loading table	

\* - non-standard dimensions of the work area available

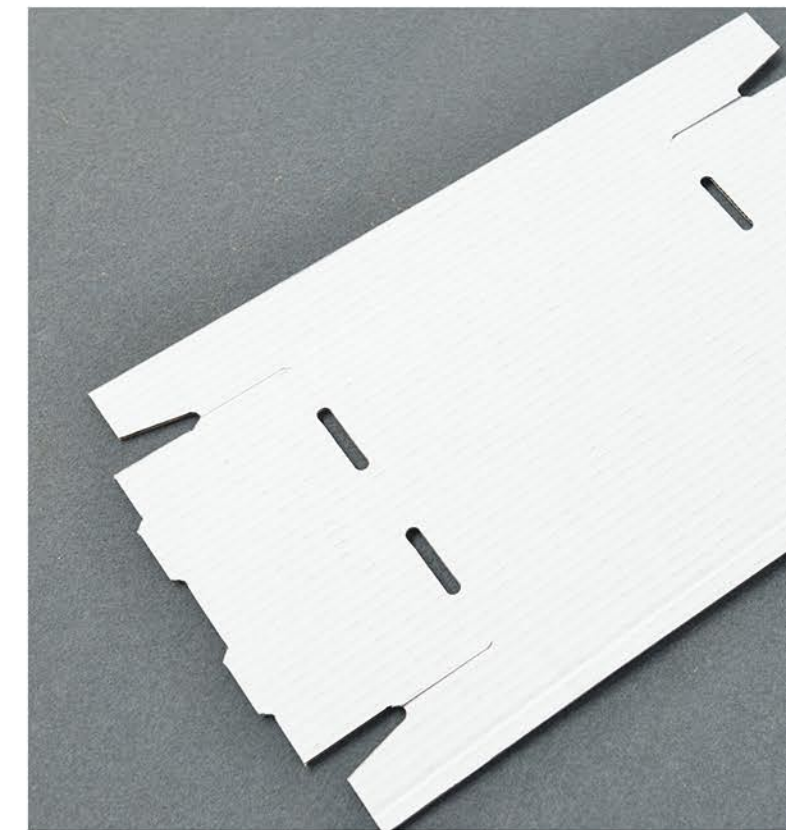

### PROCESSED MATERIALS:

- plastics;
- fabrics;
- cardboard;
- composite materials;
- Dibond;
- foams, sponges;
- laminates.

# Universal Cutter



The Kimla universal cutters are machines used for cutting out with oscillating or drag knife. All cutters are equipped with active knife, controlled with servomotors. Machines with oscillating knives may be furnished with pneumatically or electrically driven heads. Pneumatic heads are high-frequency heads, providing for very high travel speeds in soft materials. Pneumatic heads are used for highly efficient machining of foamed materials of little density. For machining of harder materials and of higher density, e.g.: sealant material, also reinforced with net and steel sheet, the electric heads are recommended that — thanks to employment of two servomotors — feature a very high power. One servomotor is used for adjusting the angle of the knife, and the other one for driving oscillating movement. The unique head power may be obtained through usage of 0.4 kW motor. It allows for performance of production works in different materials, even the ones that once used to be considered impossible to be machined with a cutter.

The universal cutter is employed also in single-layer or multiple-layer cutting of fabrics. The materials are fixated on negative pressure or vacuum tables, divided into sections, thus facilitating works in many work areas.

All machines are equipped with control panels with industrial control computer, together with the proper software. The software, except for controlling machines, allows for preparation of tool path and optimal nesting. It caters for maximum usage of the material within a very short preparation period.



## Universal Cutter

### BASIC OPTIONS

Work area dimensions* [mm]	Width [mm]	1000, 1300, 1500, 1700, 2100, 2600, 3000 ...
	Length [mm]	1500, 2000, 2100, 2500, 3100, 4100, 5100 ...
	Z axis range	100, 200, 250
Cutting head	Active, oscillating knife:	- pneumatic - electric servo
Control system		Digital AC Servo Drives
Table type		T-slot table, negative pressure table, vacuum table, hybrid table

Control cabinet with control computer

### ADDITIONAL OPTIONS

Oil mist cooling	Automatic
Heads	Creasing, Stamping, Writing
Scanner	touch, laser
Rotary axis	"B" on the table, "C" on the spindle (for angular units, for saws and mills)
Remote panel	
Presser foot	
Pressure mats	
Basing system	
Camera sighting system	
Spindle	

\* - non-standard dimensions of the work area available

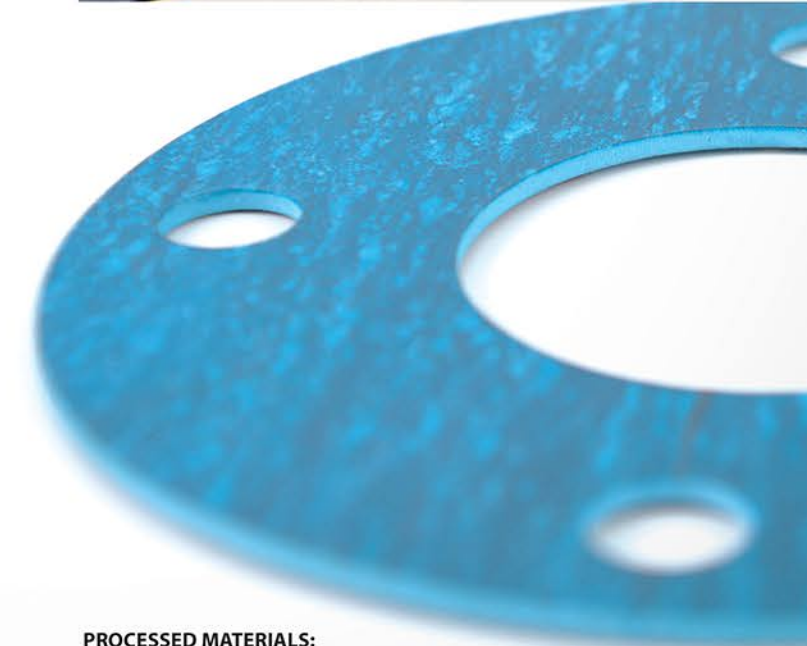
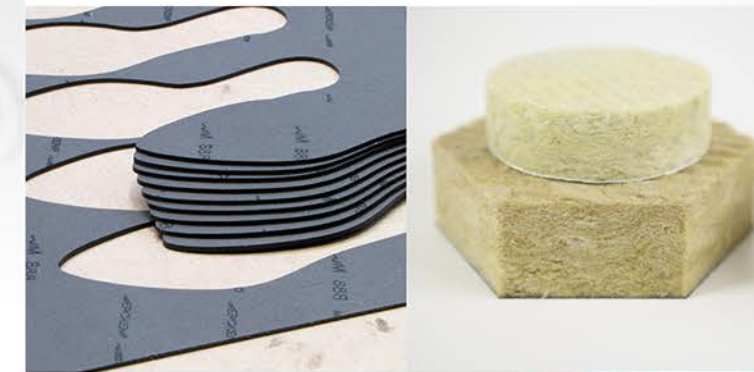
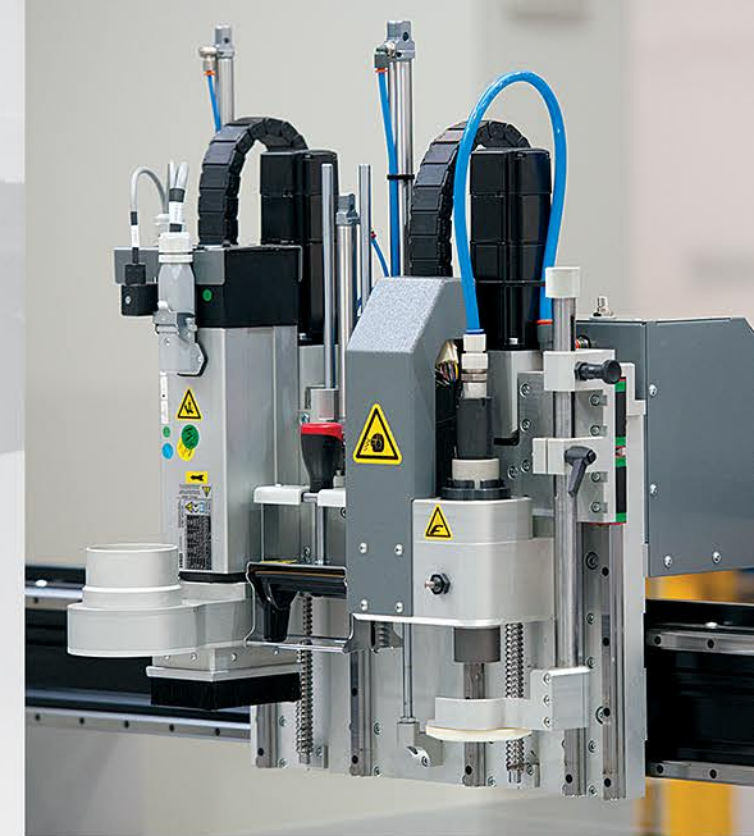

### PROCESSED MATERIALS:

- sealing boards: klingerite, gambit;
- graphite materials reinforced with net and steel sheet;
- mineral wools;
- expanded polystyrenes;
- foamed materials, sponges;
- hard foamed materials;
- fabrics;
- solid and corrugated cardboard.

# 5 Axis Milling Machine



5 axis milling machine is a machine used for large-size details machining. Most often, these are casting, thermo-forming and laminate dies. These machines may be executed in a very wide range of work areas. They are equipped with a high class control system, allowing for simultaneous interpolation of all axes, with projection of work speed onto the front of a tool. Five-axis CNC milling machines are used also for execution of production machining after thermo-forming or lamination. Finishing machinings, cutting feedheads and shape machinings may be carried out on the basis of shapes scanned with the use of touch head.

This facilitates finishing works without the need for usage of expensive CAM software. The five-axis machines are equipped with 5–30 kW spindles. The heads of the Kimla 5 axis CNC milling machines are built on the basis of no backlash harmonic gears from German company, Harmonie Drive. It provides for a high rigidity, at the same time retaining very high effectiveness and dynamics of movement.

Owing to the employment of an innovative control system, the performance of the Kimla 5 axis CNC milling machines drastically exceeds similar solutions offered by other manufacturers.



## 5 AXIS MILLING MACHINES

### BASIC OPTIONS

Work area dimensions* [mm]	Width [mm]	1500, 2100, 2600, 3100 ...
	Length [mm]	1500, 2100, 3100, 4100, 5100 ...
	Z axis range [mm]	700, 800, 900, 1000, ... 2000
	A axis range [degrees]	± 130
Spindles	C axis range [degrees]	± 213
	18 000 rpm	6kW, 7.5kW, 12kW, 16kW, 18kW, 25kW
	24 000 rpm	6kW, 8kW, 9kW, 12kW, 13kW, 16kW, 18kW
	50 000 rpm	2.4kW, 4.8kW
Control system	Cooling	Air Refrigerating unit
Automatic Tool Changing	Control system	Digital AC Servo Drives
Table type	Automatic Tool Changing	Linear storage Rotating storage
	Table type	T-slot table, vacuum table, hybrid table
	Automatic correction of the tool length	
	Control cabinet with control computer	

### PROCESSED MATERIALS:

- plastics;
- composite materials;
- MDF;
- HPL;
- aluminium;
- wood;
- model boards.

### ADDITIONAL OPTIONS

Oil mist cooling	Automatic
Scanner	touch, laser
Rotation axis "B" on the table, Pressure mats, Laser curtains, OHS fencing, Basing system, Writing head, Active head with oscillating knife, Creasing head	

\* - non-standard dimensions of the work area available

# Waterjet

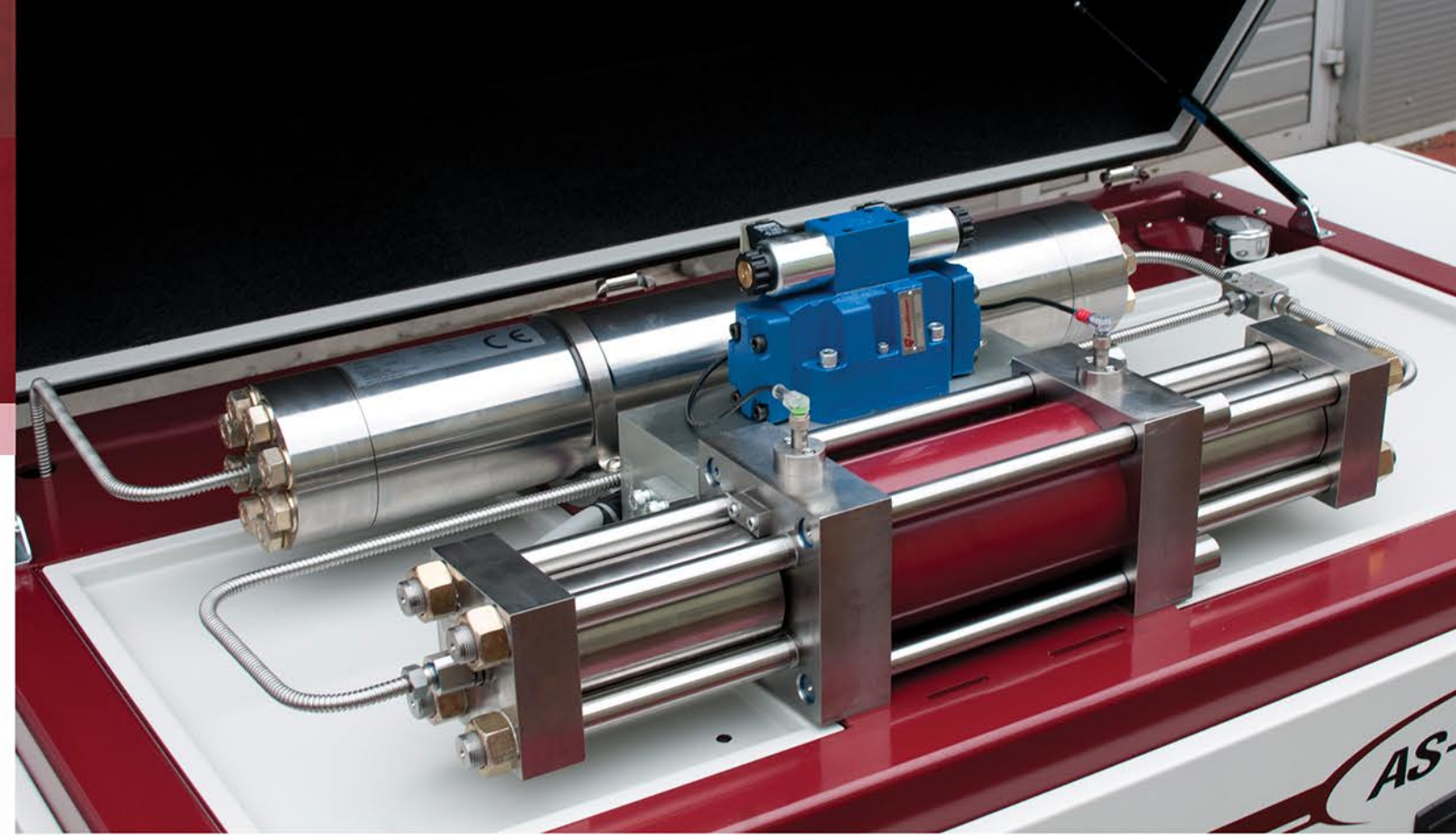

MTP 2011 Gold Medal



The abrasive waterjet technology is the most innovative solution of all currently available in the cutting technology industry. The Kimla waterjet machines may cut almost every material, starting from very soft (e.g.: foams, rubber) to very hard (e.g.: stone, ceramics). The thickness of the cut materials reaches almost 220 mm. This is a feature that the majority of other shape cutting technologies are unable to accomplish. The advantage of the waterjet machines is that the kerf features very small width, below 1 mm, which allows for cutting of highly complex shapes and precision adapting by cutting off corners. The Kimla waterjet cutters are used in metal industry, stonework branch, construction branch and wherever there is the need for cutting in thick materials.

The waterjet machines manufactured by Kimla company are equipped with high-pressure pump with pressure amplifier and equipment manufactured by the US company Accustream. The Accustream pumps distinguish themselves with the lowest maintenance costs, which greatly increases the profitability of the investment.

The Kimla machines are equipped with abrasive adjustment unit from Accustream, with the smoothly adjusted amount of abrasive supplied to the head. This allows for precision dosing of the abrasive, depending on the cut material and specific machining conditions. The possibility of adjustments positively influences the reduction of cutting costs, thus minimizing usage of the garnet.

The jet of water with the abrasive allows to pierce through the hardest materials from the inside. Therefore, it makes possible to cut a closed object, without the need to enter the material from the outside - opposite to the situation of cutting with a line.

Some materials - e.g. glass - are prone to crack and chip during piercing. In order to prevent this, the Kimla machines feature the functionalities of low-pressure piercing. Thus, it makes the adjustment of jet impingement during material piercing possible.

There are five axis versions, which facilitate change of the head angle so that cutting with inclined wall is also possible (e.g. bevelling for welding purposes). The Kimla waterjet machines are characterised by uniquely rigid, spatial design of the tub and the very self-supporting structure. Thanks to this, the machines does not need to be mounted to the floor, and does not require special foundation.

The Kimla waterjets feature air cushion, which caters for cutting under the surface of water, reducing noisy operation and water splashes.

To support the cut material, the Kimla waterjets were equipped with segment grille, consisting of long strips of galvanised sheet metals, set in comb-shaped holders. This facilitates the assembly of fins in any location on the table and creation of less or more concentrated. And this provides for their long service life and effective usage.

## WATERJETS

Waterjet type	Waterjet KIMLA 2111	Waterjet KIMLA 3116	Waterjet KIMLA4121	Waterjet KIMLA 2161
Working range [mm] (dimensions of the cut sheet)	2100 x 1100	3100 x 1600	4100 x 2100	2100 x 6100
Operational weight of a tub filled with water [kg]	4500	6200	9800	12000
Max. cutting thickness [mm]	200			
Pump type	Pump with amplifier, together with ceramic plungers (very durable)			
Pump power	37 kW (50 hp), AccuStream company, USA			
Max. pump pressure [bar]	4,150			
Pump expanding system	Reducing pressure during travel and after switching off the pump			
Cutting head drive	AC servo with digital encoders			
X and Y axes drives	AC servo, no backlash helical drive, Güdel, Switzerland			
X axis drive	AC servo, ball screw			
Maximum travel speed: X, Y, Z [m/min]	54			
Range of motion in Z axis	200, 250, 300, others on request			
Allowable table load [kN/m <sup>2</sup> ]	15			
Tub	3D multi-chamber design of very high rigidity			
Positioning resolution [mm]	0.001			
Abrasive grain size [mesh]	80-200			
Abrasive feeder tank [kg]	300, 1,000			
Abrasive delivery system	Pneumatic			
Height adjustment	Automatic			

## PROCESSED MATERIALS:

- steel: carbon, alloy, stainless, heat resistant (in soft and hardened state);
- stone;
- non-ferrous metals;
- ceramics, glass;
- foamed materials: foams, gels, sponges;
- plastics;
- composites.

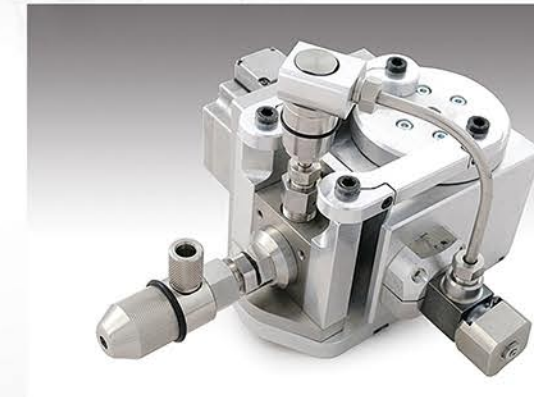

# High-Speed Engraver



The Kimla High Speed engravers are machines designed for high precision machining of small details. They may be used also for milling of various details: stamps, metal dies (including those made of toughened or hardened steels), nameplates, description plates and elements that should be machined with tools of very small diameters.

High Speed engravers facilitate engravings both plain and three-dimensional. The machines may be additionally equipped with the fourth or the fifth axis, which allows for machining of details, from different sides and over one fixation period.

The machines may be equipped with spindles of 24,000–60,000 rpm, featuring power of 0.8–3 kW, and also with the automatic tool changing system with a storage. As a standard, the sensor of automatic tool length correction is installed. This allows for precision machining, irrespective of the depth of the tool mounted in the chuck.

**PROCESSED MATERIALS:**

- non-ferrous metals;
- tool steels (toughened or hardened);
- composite materials;
- plastics.



**Model for dental technicians**

Possibility of machining in:

- zircon
- chromium-cobalt
- glass
- wax

HIGH-SPEED ENGRAVERS



BASIC OPTIONS			
Work area dimensions* [mm]	Width [mm]	400	90
	Length [mm]	375	90
	Z axis range [mm]	130	80
Spindles	24 000 rpm	1.0kW, 1.5kW, 2.1kW	
	60 000 rpm	0.8kW, 0.97kW, 2.1kW	0.8kW, 0.97kW, 2.1kW
Cooling	Air Refrigerating unit		
Control system	AC digital servomotors		
Table type	T-slot table, vacuum, hybrid,		special
Automatic correction of the tool length			
ADDITIONAL OPTIONS			
Cooling	Automatic, with oil mist	air + liquid	
Heads	Knife for cutting film, Writing, Pouring		
Scanner	Touch, Laser		
Automatic tool changing	Depending on the type of the spindle.		
Rotary axis	"B" on the table	"A" "B" on the table	
Control computer, Dust extraction system, Basing system			

\* - non-standard dimensions of the work area available

# Milling Router



The Kimla milling routers are machines designed for wide range of customers. They are designed for light machinings with tools of little diameters in soft materials.

The milling routers are widely used in production of advertising elements. This series machines are recommended especially for advertising companies, service providers, packaging and blanking die manufacturers, as well as prototype design offices.

All machines are equipped with control systems with dynamic vector analysis™, smooth travel speed and spindle revolutions adjustment. The guides, ball screws and optical limit switches are covered, thus securing just a minimum of servicing tasks connected with cleaning and maintenance of the machine.

The machines may be equipped with spindles of 24,000–60,000 rpm, featuring power of 0.8–2.5 kW, and also with the automatic tool changing system with a storage. After changing the milling head to cutting head with creasing function, there is a possibility of producing packaging through cutting out and creasing paperboards, cardboards or foamed materials,

**PROCESSED MATERIALS:**

- plastics;
- solid wood and wood-based materials;
- HPL;
- foams, sponges;
- layered materials;
- non-ferrous metals.

**MILLING ROUTERS**

**BASIC OPTIONS**

Work area dimensions* [mm]	Width [mm]	500, 700, 1000, 1200, 1500, 2100
	Length [mm]	400, 700, 800, 1000, 1200, 1500, 2000, 2500
	Z axis range [mm]	150, 200
Spindles	24 000 rpm	1.0kW, 1.5kW, 2.1kW, 2.5kW
	60 000 rpm	0.8kW, 0.97kW, 2.1kW
Control system	AC digital servomotors	
Table type	T-slot table, vacuum table, hybrid table	

**ADDITIONAL OPTIONS**

Oil mist cooling	Manual Automatic
Heads	Active, oscillating knife Creasing Active, with knife Knife for cutting film
Other heads	Writing Pouring
Scanner	touch, laser

- Automatic tool changing (for spindles running at 60,000 rpm)
- Control cabinet with computer
- Presser foot, Suction foot
- Dust extraction system
- Camera sighting system

\* - non-standard dimensions of the work area available

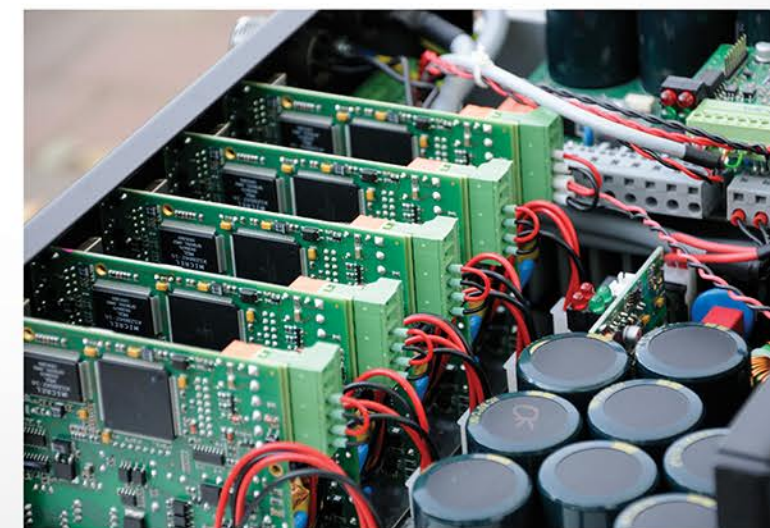
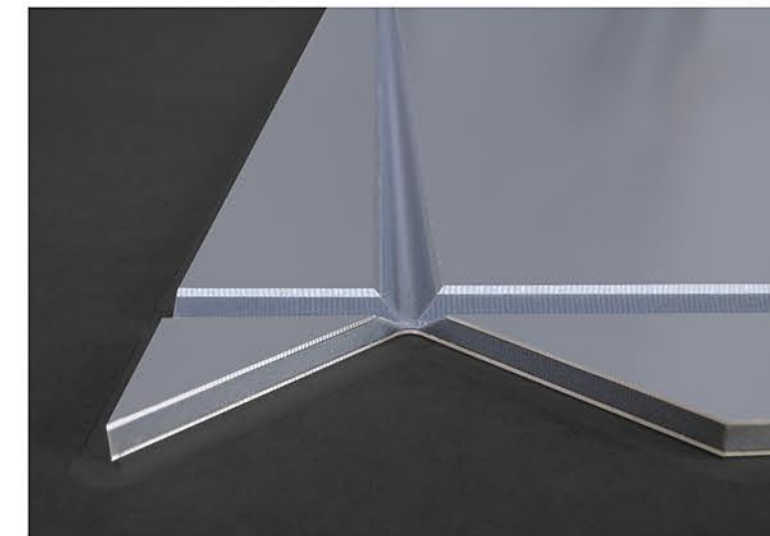



# KIMLA

ul. Bałtycka 30, 42-202 Częstochowa, Poland  
phone: +48 34 365 88 85, fax: +48 34 360 86 11  
email: [kimla@kimla.pl](mailto:kimla@kimla.pl)  
[www.kimla.pl](http://www.kimla.pl) [www.laserfiber.pl](http://www.laserfiber.pl)



The above offer is for information only and does not constitute trade offer in the meaning of Art. 66, § 1 of the Civil Code. The manufacturer reserves the right to change parameters without prior notice. The manufacturer is not liable for any printing errors.