

Profile

- Repeat accuracy max. $\pm 1 \mu\text{m}$
- Max. resolution $0.2 \mu\text{m}$ (LD output circuit)
- Reading distance $\leq 0.2 \text{ mm}$
- Works with MB100/1 magnetic tape
- Signal period $1000 \mu\text{s}$
- Output circuit sin/cos or LD
- Function and status display LEDs

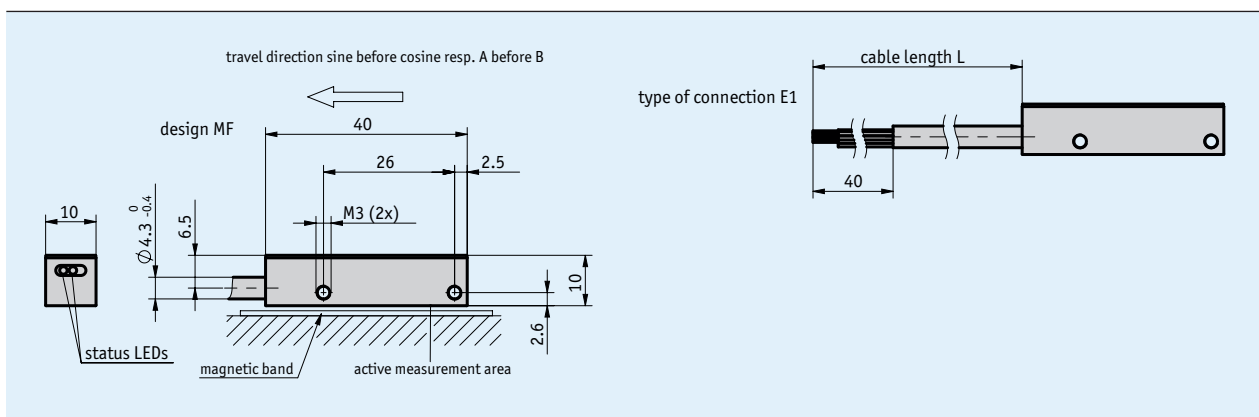
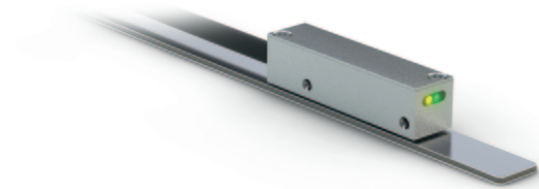

Mechanical data

Feature	Technical data	Additional information
Housing	zinc die-cast	
Sensor/band reading distance	$\leq 0.2 \text{ mm}$	
Cable sheath	PUR, suitable for drag-chain use	8-core $\varnothing 4.3_{-0.4} \text{ mm}$
Cable bending radius	5x cable diameter	static
	10x cable diameter	dynamic
Weight	$< 0.03 \text{ kg}$	(without cable); cable 0.028 kg/m

Electrical data

Sin/cos output

Feature	Technical data	Additional information
Operating voltage	5 V DC $\pm 5 \%$	reverse polarity protected
Current consumption	$< 50 \text{ mA}$	off-load
	$< 100 \text{ mA}$	loaded
Status display	2 LEDs (yellow/green)	
Output signals	sin, /sin, cos, /cos, index, /index	
Output voltage	$1 V_{pp} \pm 10 \%$	at $0 \dots 70 \text{ }^\circ\text{C}$, 120Ω terminal resistance
Signal period	$1000 \mu\text{s}$	
Offset voltage	$UB/2 \pm 100 \text{ mV}$	sine/cosine mean to GND (5 V DC)
Phasing	$90^\circ \pm 1^\circ$, $\pm 3^\circ$ (20 kHz)	sin/cos
	45°	sin (reference signal)
	135°	cos (reference signal)
Pulse width of reference signal	$180^\circ \pm 40^\circ$	
Real-time requirement	speed-proportional signal output	
Type of connection	open cable end	

LD output circuit

Feature	Technical data	Additional information
Operating voltage	5 V DC±5 %	reverse polarity protected
Current consumption	<50 mA	no load
	<120 mA	loaded
Status display	2 LEDs (yellow/green)	
Output circuit	LD (RS422)	
Output signals	A, /A, B, /B, R, /R	
Output signal level high	>2.5 V	
Output signal level low	<0.5 V	
Pulse width of reference signal	1, 2, 4 increment(s)	
Real-time requirement	speed-proportional signal output	
Type of connection	open cable end	

Signal pattern, Sin/Cos output

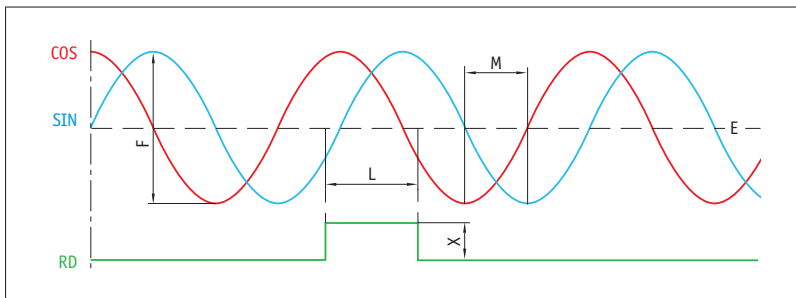

E: reference voltage 5 V
 F: $1 V_{SS} \pm 10 \%$
 L: $180^\circ \pm 40 \%$
 M: $90^\circ \pm 1.0^\circ / \pm 3^\circ$ (25 kHz)
 X: $1 V_{SS}$

Signal pattern, LD output circuit

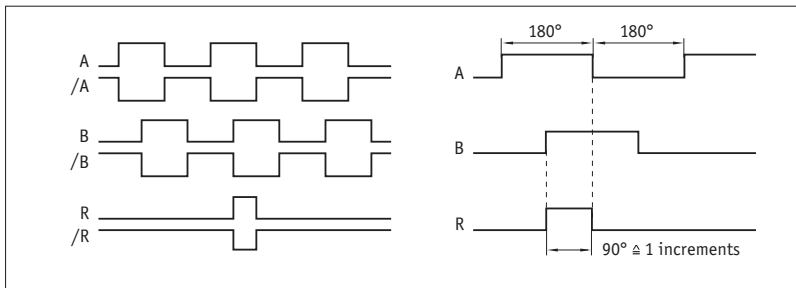

! The logic status of signals A and B is not defined regarding the reference signal RD or R. It may deviate from the signal pattern.

! Reference or index signal with 4 increments (360°) signal length is only valid from the 5th counting step onwards. A corresponding delay should be taken into consideration after switching on the operating voltage.

Pulse interval, LD output circuit

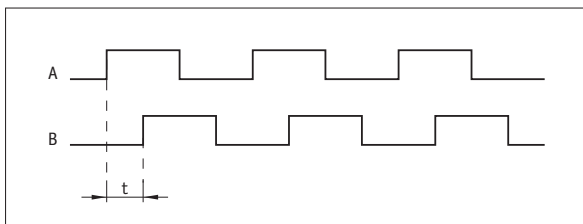

Example: Pulse interval $t = 1 \mu s$
 (i. e., the downstream unit must be able to process 250 kHz)
 Formula for counting frequency = $\frac{1}{1 \mu s \times 4} = 250 \text{ kHz}$

System data

Feature	Technical data	Additional information
Pole length	1 mm	
Resolution	0.2, 0.5, 1, 2, 5, 10 μm	LD output circuit
System accuracy	$\pm 8 \mu m$	with MB100/1 accuracy class 10 μm , TU = 20 °C
Repeat accuracy	$\pm 1 \mu m$	unidirectional
Measuring range	∞	
Travel speed	$\leq 25 \text{ m/s}$	analog
	$\leq 25 \text{ m/s}$	LD output circuit, see table, referencing speed $\leq 5 \text{ m/s}$

Travel speed, LD output circuit

Resolution [mm]	Travel speed Vmax [m/s]						
	0.2	1.60	0.80	0.64	0.32	0.16	0.08
0.5	4.00	2.00	1.60	0.80	0.40	0.20	
1	8.00	4.00	3.20	1.60	0.80	0.40	
2	16.00	8.00	6.40	3.20	1.60	0.80	
5	25.00	20.00	16.00	8.00	4.00	2.00	
10	25.00	25.00	25.00	16.00	8.00	4.00	
Pulse interval [μs]	0.10	0.20	0.25	0.50	1.00	2.00	
Counting frequency [kHz]	2500.00	1250.00	1000.00	500.00	250.00	125.00	

Ambient conditions

Feature	Technical data	Additional information
Ambient temperature	-40 ... 85 °C	
Storage temperature	-40 ... 85 °C	
Relative humidity	100 %	condensation admissible
EMC	EN 61326-1 EN 61000-6-2	immunity requirement of industry class B emission limit
Protection category	IP60	EN 60529
Shock resistance	≤500 m/s ² , 11 ms	EN 60068-2-27, half-sine, 3 axes (+/-), each 3 pulses
Vibration resistance	≤100 m/s ² , 10 ... 2000 Hz	EN 60068-2-6, 3 axes, each 10 cycles

Pin assignment

Signal Sin/Cos	Signal LD	Cable color
Sin	A	red
Cos	/A	yellow
RD	R	blue
+UB	+UB	brown
GND	GND	black
/Sin	B	orange
/Cos	/B	green
/RD	/R	violet

Hint for mounting

For systems with reference points on the magnetic tape please take care that sensor and strip are correctly aligned (see picture).

Reference signal	R, RD
A, Sensor/tape reading distance	≤0.2 mm
B, Lateral offset	±0.5 mm
C, Alignment error	±3°
D, Longitudinal inclination	±1°
E, Lateral inclination	±3°

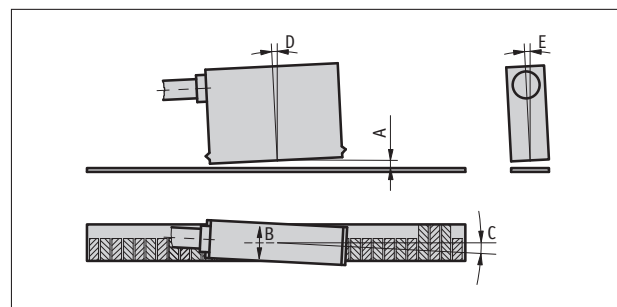

Symbolic representation

Order

Ordering information

One or more system components are required:

Magnetic band MB100/1

www.siko-global.com

Ordering table

Feature	Ordering data	Specification	Additional information
Cable length	... A	01.0, 02.0, 03.0 in m	
Output circuit	1Vss	Sin/Cos, 1 V _{SS}	
	LD	Line Driver	
Reference signal	RD	fixed reference (digital)	only with output circuit 1Vss
	R	fixed reference	only with output circuit LD
Resolution	...	no information required	only with output circuit 1Vss
	D	0.2, 0.5, 1, 2, 5, 10 in μm	
Pulse interval	...	no information required	only with output circuit 1Vss
	E	0.1, 0.2, 0.25, 0.5, 1.0, 2.0 in μs	

Order key

LEC100 - MF - E1 - - - - -

A B C D E

Scope of delivery: LEC100, Quick Start Guide